

# SOII

fall-protection.com



Fall protection systems

Bacou-Dalloz

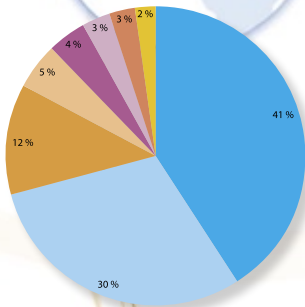

### The major causes of injury in the workplace

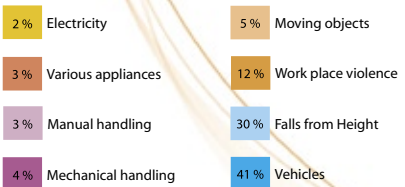

# The Law requires protection against falling from height

Building owners and managers must provide safe systems of work!

### Why fall protection?

#### Gravity kills!

Falls from height are one of the leading causes of serious injury and death at work. Analysis of all industrial accidents usually highlights inappropriate working conditions as a principal factor. In the case of work at height the consequences are immediate and serious, resulting in major disability or death. Approximately one in seven work place fatalities are due to a fall from height.

### What the Law says!

According to the European directive 89-686, the employer or company responsible must put fall protection measures in place for persons working at height. The employer should try to minimise the risk through design or engineering controls and provide measures to prevent falls. If this is not feasible then other protective measures should be considered, such as personal fall protection equipment and systems.

## Söll has an apt solution for every application.

### Which system is the correct one?

Various systems are available in the market and they differ in their design and application significantly. Safety features, functions, handling and ease of use, should all be evaluated. Additionally; durability, maintenance costs and long-term value should be assessed in order to select the best system.

In all cases, fall protection systems should be designed for each specific application. This will minimise the risk of a fall from height and maximise the efficiency of the work being carried-out.



# Reach the Sky with the GlideLoc® Safe Climbing System

These fall protection and anchorage devices are used in: telecommunications, radio and TV masts, construction, power supply and hydroelectric installations, wind power facilities, chimney and industrial plants, buildings and facades, petrochemical plants, on-shore and off-shore oil rigs, shipbuilding, crane installations, shafts and manholes, aircraft hangars and for loading/unloading of trains and vehicles.



**Wind turbine** with galvanized steel ladder



**Chimney** with retrofitted guide rail



**Telecom-station** with aluminium ladder on the Zugspitze



**Floodlight mast** for stadium lighting with galvanized steel ladder

**Söll GlideLoc®** is a fall protection system, permanently installed on buildings, towers, masts, etc... comprising a **guided type fall arrester**, which glides up and down a steel or aluminium notched **guide rail**. The rails can be retrofitted to **existing ladders**, or alternatively are incorporated in a complete **safe climbing system**. A wide range of mounting brackets are available for fixing to most structures.

## Enhanced safety and greater versatility

The GildeLoc® Safe Climbing System includes vertical and horizontal anchorage devices with an extensive range of accessories, thus making it possible to adapt the system to most structural profiles.

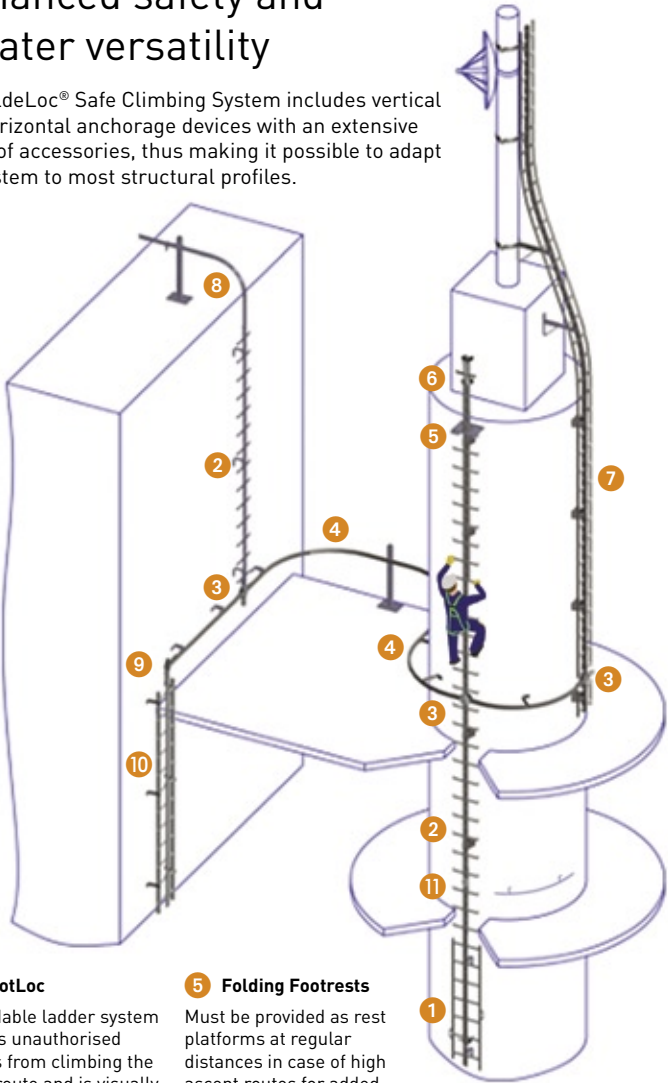

### 1 PivotLoc

The foldable ladder system prevents unauthorised persons from climbing the ascent route and is visually much less obtrusive than a ladder.

### 2 Y-Spar

Cost-effective alternative. The low surface area keeps wind loads applied to the sub-structure to a minimum.

### 3 Turntable

Allows safe continuous transfer from ladders to horizontal rail and vice versa without disconnecting.

### 4 Horizontal Guide Rail

Available both straight and curved, which allows safe access along narrow platforms.

### 5 Folding Footrests

Must be provided as rest platforms at regular distances in case of high ascent routes for added safety.

### 6 Rotary Exit Section

Climbers can safely access and egress the top of the guide rail while standing on the upper platform.

### 7 Twin Ladder

The operator can glide his hands along the side stringers when ascending without having to hold onto the rungs. Ideal for dirty surroundings. Offers high distortion resistance.

### 8 Twisted Change-over rail

Allows a climber to move safely onto a roof or a platform away from the edge of the roof before disconnecting from the system.

### 9 Ho-Ver Turn Table

Simple means of changing direction from the end of a vertical rail to a horizontal rail and vice versa.

### 10 Vertical Guide rail

Can be assembled on existing ladders, step irons etc. An ascent route protected in this way offers the same protection as Söll's safe climbing systems.

### 11 Exit Section

A climber can detach the fall arrester from the rail after ascending and insert it into the rail before descending.

## Technology & Expertise from Professionals for Professionals

### The heart of the system is the guided type fall arrester

The user wears a safety harness before climbing onto the system. The fall arrester, also known as fall arrest shuttle, is attached to the front of the harness using the incorporated karabiner.



The fall arrester is inserted into the guide rail. When climbing or descending, the fall arrester glides smoothly in the guide rail. The ergonomically shaped full body harness provides stability to the user.

### In the event of a fall...

...the fall arrester prevents free falling by self-locking in the rail and stopping the fall within a few centimetres, offering complete safety at whatever position or height. According to EN 353, part 1, the arresting force on the user must not exceed 6 kN (1350 lbs.). Fall arrest forces of GlideLoc fall arresters are less than 4 kN (900 lbs.).

### Meets all global safety standards

The GlideLoc system meets global safety standards (CE, OSHA, ANSI, AS/NZS, CSA).

Thanks to its high safety standards, ease of use and versatility, Söll Safe Climbing Systems have been adopted by companies such as General Motors, German Telekom, France Telecom, Transocean, Siemens Powerlines, SPIE Trindel, Sagem, Ericsson, CEGELEC (Alstom), Alcatel, Ford, German Railways, Austrian Railways, BHP Australia, Vodafone New Zealand, United Rail Australia.



## The permanent safe climbing system

**GlideLoc® systems are available as ladders as well as guide rails.**

Fall protection ladders have an integrated guide rail for the guided-type fall arrester as the centre stile. They are available in aluminium, galvanized steel and stainless steel, either with or without side stringers:

**Anodized Aluminium:** For high corrosion and distortion resistance, good appearance and ergonomic support.

**Hot dipped galvanised steel:** The cost effective solution for general applications.

**Stainless steel:** Suitable for harsh environments such as chemical plants, food industry, off-shore and industrial chimneys and shafts.



### The Y-Spar Ladder

The so-called Y-spar is a cost-effective option. The low surface area keeps wind and snow loads transmitted on to the sub-structure to a minimum.

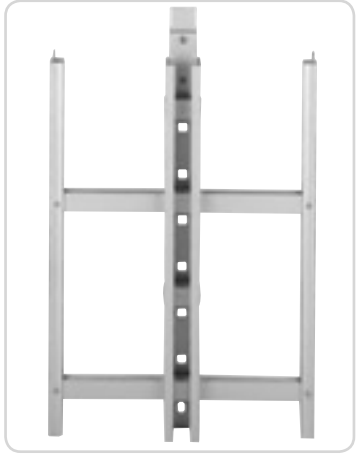

### The Twin Ladder

The operator can slide his hands along the side stringers when ascending without having to hold onto the rungs. Ideal for dirty environments. Söll Twin Ladders offer high distortion resistance.



## A reliable solution

### Vertical Guide Rails

Can be assembled on existing ladders, step irons etc. An ascent route protected in this way offers the same protection as Söll's vertical ladders.

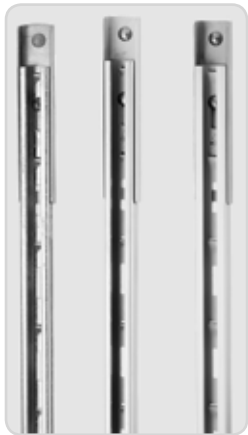

### Horizontal Guide Rails

The EN 795 compliant anchorage devices are based on guide rails and are designed to provide a safe working environment for people working at height. The worker wears a full body harness and uses a lanyard (or other connector compliant with EN 354/EN 355) to connect to the eye of the shuttle, which travels along the GlideLoc rail. For overhead applications a retractable fall arrester can be used to provide the most effective means of protection.

Horizontal Guide Rails can be fixed on the ground, to walls or even overhead - fixing span of 1 m (40 in.). Available in lengths of up to 4 m (13 ft.) in straight or curved form and made of aluminium, galvanised steel or stainless steel. Suitable for up to 3 persons at a time and can allow continuous transfer to vertical guide rails using a turntable.





# Söll GlideLoc® fall arresters are some of the safest and most innovative products in the market.

The patented new COMFORT fall arrester provides the connection between the full body harness worn by the worker and the guide rail. This combination ensures complete safety during descent and ascent, with or without leaning back. The stainless steel catch locks onto the rail in the event of a fall.

### **Operates with and without leaning back**

Other fall arrest systems require the User to lean backwards, to allow the device to unlock and slide. This is difficult in confined spaces and the User has to move the device manually. This can be dangerous and discourages use of the system. With the COMFORT fall arrester, leaning back is not necessary and the device will travel smoothly in all applications.



### **COMFORT**

The integral karabiner is double self-locking and is made from light-weight aluminium. It ensures extremely short arrest distances and low arrest forces of only 3.7 kN (832 lbs.).



### **COMFORT 2**

Made entirely of **stainless steel**. The functional design of COMFORT 2 is identical to the aluminium shuttle and offers additional advantages since it is designed for severest stresses, is extremely durable and easy to clean.



### **UNIVERSAL II**

can be inserted into or detached from the rail at any location. The body and the opening mechanism of the patented fall arrester are made from stainless steel.



### **COMFORT UK**

With double self-locking karabiner and strap webbing for rescue actions which require the cutting free of the injured person.



## The foldable ladder system

PivotLoc is a foldable ladder system with incorporated GlideLoc-fall protection rail. In the closed position, the rungs pivot together behind the central guide rail.

### Access Prevention

The PivotLoc aluminium ladder system is a cost effective, innovative alternative to the cover plate. Through its unique and award winning design the PivotLoc can be closed when not in use thus preventing unauthorised access. The PivotLoc can be locked while working in the open state, so as to prevent an operator from being trapped accidentally.

### Discreet

Once the side rails have been folded together, the ladder is very discreet (105 mm (4 in.) wide in the closed position) thus meeting architectural and planning requirements for an "invisible" height access system.

### Versatile

PivotLoc can be used in conjunction with all other SÖLL ladder systems or the entire ladder can be assembled using PivotLoc elements. Side members are light and easy to move since their weight is counter-balanced. They provide additional support to the user while ascending and descending.

### Robust

Manufactured from saline-resistant anodised aluminium. The system absorbs minimal wind and snow loads in the closed state.

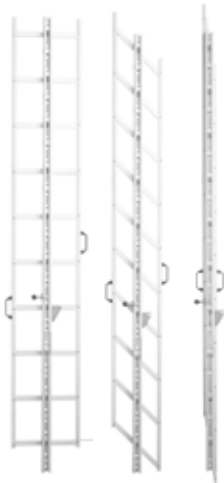



## Company

**Bacou-Daloz** is the World's leading manufacturer of individual personal protective equipment for the workplace or high-risk environments. The group comprises three divisions; head, body and fall protection, which combine to offer complete head to toe protection.

With sales offices and factories worldwide, we are able to offer safety solutions that conform to global standards (CE, OSHA, CSA, ANSI, AS/NZS).

Under the umbrella of Bacou-Daloz, the **Söll** product line offers you a broad, specialized range of fall protection systems & services. Established by Karl Söll as an industrial foundry in 1921, the firm has been developing and manufacturing ladder climbing safety systems and components for fall protection since 1969. Today the brand Söll is synonymous with efficiency and quality in height access & fall protection solutions.



## Horizontal anchorage devices: Where is the difference?

### Installation along the entire falling zone

Compared to anchorage points which only offer the user a limited freedom of activity dependent on the length of the lanyard, MultiRail rail systems can be installed along the entire work area and allow continuous connection and greater protection.

### Can also be used as a handrail

Compared to cable systems and anchorage points, horizontal guide rail offers the advantage that they can be also installed as handrails.

### Energy distribution via multiple intermediate brackets

In case of a fall, the forces are absorbed by several intermediate brackets and not just by both of the end-fixings, as is the case with cable systems, or by a single point, as it is the case with anchorage points.

The rail can absorb retention forces of up to 100 kg (220 lbs.) without permanent deformation. The rail is not fixed in the intermediate brackets, enabling thermal expansions to be accommodated.

### Greater fixing spans

Also, compared with traditional horizontal guided rail, MultiRail offers the advantage of greater fixing spans up to 4 m (13 ft.) and can be used by more people at the same time (up to 6).



The openable glider can be attached anywhere on the horizontal guide rail. It can be opened or closed by turning the knurled nut.



In addition to conventional lanyards, retractable fall arresters can be used on MultiRail-Systems, such as the Söll-MiniLite®, Miller Falcon™, Miller Scorpion™ and Miller Black Rhino™ Self-Retracting Lifelines.



## Innovative and versatile

The MultiRail horizontal anchorage device is often used in the following sectors: Store-fronts, Flat roofs or steep roofs, Working platforms on masts and buildings, Hangars, Shipyards, Cranes, Industrial plants etc.



With the MultiRail System, vertical sections of up to 1 m (40 in.) are allowed.



### Worth Knowing

When the system is installed within reach of the User, it allows the User to connect and disconnect the PPE from the rail.

The rail can be installed at angles of up to 5 degrees.



### Openable Shuttle

Can be detached and re-attached at any point along the rail

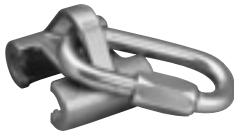

### Closed shuttle

Robust, easy to use and low cost, operates with a gliding action.



### Wheeled Shuttle

For overhead applications, particularly effective where heavy retractable fall arresters are used.

**NEW**



## The highest quality and best value life line

### Safe protection against falls

The Xenon Horizontal Lifeline is an anchorage device incorporating a flexible wire rope. The principal components of the system are; shuttles, shock absorbers, intermediate anchors and end anchors. The Xenon Horizontal Lifeline can provide the perfect safety solution for installation, maintenance and cleaning at height. It can be used; in industrial plants, on roofs, on cranes and over vehicles.

### Tested and certified

The Xenon anchorage device from Söll has been tested by an independent EU Notified Body, it is CE-certified and complies with the requirements of EN 795.

**A range of versatile and high-quality stainless steel components makes installation and inspection of systems simple and cost-effective.**



### Shock absorber

The new shock absorber has 4 essential functions in one unit, these are; a shock absorber, a line tensioner, a tension indicator and a fall indicator. Thanks to the new 'Structure Guard' technology loads applied to system anchor points can be reduced to 6.5 kN (1462 lbs.).



### Stainless steel wire rope

Stainless steel wire rope with a choice of 8 mm (5/16 in.) or 10 mm (3/8 in.) diameter can be used. The 8 mm (5/16 in.) wire rope is certified for use by up to 4 persons and up to 15 m (49 ft.) spans, the 10 mm (3/8 in.) wire rope is certified for use by up to 7 persons and up to 20 m (65 ft.) spans.



### Shuttles

High-strength, robust and ergonomically designed, with a dual locking mechanism. Smooth passage through brackets without the need for alignment or adjustment by the user. Extra-wide eye for safe attachment of all types of connectors compliant with EN 355 & EN 360.



### Intermediate Brackets

Smooth movement of the shuttle is guaranteed by Xenon intermediate brackets. Brackets can be assembled on a fitted cable allowing easy replacement.



### Corner Kits

Exceptional adaptability and easy cable installation. Can be fixed to internal and external corners, and to double-point or single-point posts. Pre-formed and site adjustable units are available.



### Cable End Parts

Swaged and swageless options are available for all end parts. Allows choice of lower cost components using a swaging press, or quicker installation with standard hand tools.



# Xenon - areas of application

## Overhead applications

Common areas of application include; vehicle bays, crane tracks, warehouses and aircraft hangars.

### How can you provide protection against falls with maximum freedom of movement?

The Xenon Horizontal Lifeline can be fixed above the user's work location. The shuttle will move along the cable above the worker, minimising any pendulum swing during a fall. A rope and grab system or automatic retractable fall arrester can be attached to the shuttle to provide a safe range of both vertical and horizontal movement.



### Combine horizontal and vertical systems!

Where the system has large spans or a heavy retractable fall arrester is used for very high systems, then the over-head shuttle can be used. The overhead shuttle has wheels that run on the cable and (when combined with the overhead intermediate bracket) allows smooth continuous passage along the full length of the cable.



## Installation for walls and masonry

The Xenon fall protection system can be installed on most walls or facades using appropriate structural fixings. The versatile range of end anchors, corners and intermediate brackets always allow for an appropriate bespoke system layout.

Using shock absorbers with Structure-Guard-Technology, loads are minimised allowing the Xenon system to be installed on to weak substrates, such as aluminium profiles or masonry.



## Installation on roofs

Carrying out regular maintenance activities on ventilation systems, lights or windows require protection systems due to the significant risk of a fall. Xenon can be configured as either a fall restraint system or a fall arrest system. When using a fall restraint system, the user is restrained and can work only in the zones where there is no risk of falling. A fall arrest system does not prevent a fall, but arrests the fall in a controlled manner. Selecting the appropriate roof posts enables simple and cost-effective installation on different types of roofs.

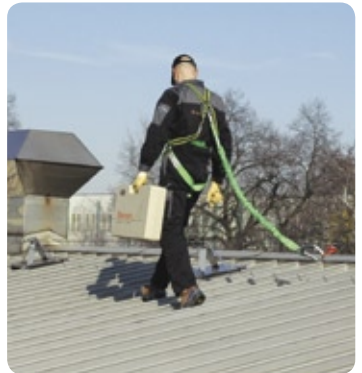

# Xenon - areas of application

## Safety for every work environment

Söll's **safety devices** offer the highest possible safety. Technically advanced retractable type fall arresters and descender devices as well as rescue devices and silo conveyer devices by Söll ensure this.

You can use the retractable type fall arresters flexibly to provide adequate protection against falling. Simple handling and practical accessories offer highest safety in almost every working condition.

Descender devices, evacuators, conveyer systems and load securing devices can be used for varied areas of application. These are available in different sizes and models depending on the requirement. Not only do they fulfil prevailing guidelines, but also provide reliable protection to your employees while conveying silos, descending or securing hazardous loads.



Load Arresters



MiniLite

### Crane descender



### Self-retracting lifeline



Tripod





## Well equipped to handle every situation

**Safety harnesses** can include up to 4 attachment points to cover a range of work applications. During vertical climbing, the guided type fall arrester is connected to the front attachment point; for general work at height the lanyard (or other connecting device) is attached to the front or rear attachment point; and the side D-rings are used with a positioning lanyard for a hands free work position. All harnesses conform to EN 361 and, where applicable, EN 358.



### Lanyards

Available in rope or webbing, the Söll lanyards include a range of karabiners to suit the specific applications. The fall arrest lanyard limits the free fall of the worker and should be selected based on work to be performed and the work environment. The positioning lanyard is used to secure a person in a comfortable hands-free work position and should always be used with an additional fall arrest device.



# Anchorage points for all types of applications

Söll offers a series of permanent and temporary anchorage points for protection against falls.



### MultiPost-AP

MultiPost is available in different lengths for three types of fixing bases (concrete, steel beams and timber structures). Posts are designed such that they do not deform due to the stresses resulting from a fall. MultiPost is used especially on roofs. It is EN 795 Class A & B compliant. The anchoring eye serves as a fall indicator.



### MAP - Mast anchorage points

Söll mast anchorage points (MAP), made of half-clamps are permanent anchorage points that are tested as per EN 795 - Class A1. These can be fixed on masts of suitable strength and having diameters between 60 (2.4 in.) - 1300 mm (51 in.).



**The clamp with an eye** is a single anchorage point for mast diameters between 60 (2.4 in.) - 300 mm (12 in.).

The **retaining ring** is designed for the use by 6 persons at a time and is available for mast diameters between 60 (2.4 in.) - 1300 mm (51 in.).



### RAP - detachable anchorage point

The Söll RAP is a temporary anchorage point for 2 simultaneous users comprising RAP-anchor sleeve and a detachable RAP-ring eye as the main components. It has been tested as per EN 795. The anchor sleeve is either fixed in concrete or bolted onto suitable structures and can be closed discreetly with a sealing cap when not in use.

Press the unlock key, insert the ring eye into the sleeve and it is ready-to-use.



### WAP - wall anchorage point

Can be fixed on steel structures or walls made of non-cracked concrete (minimum concrete thickness of 165 mm (6.5 in.) and is approved for use by one person as per EN 795. The fall indicator releases at a load > 3.5 kN (790 lbs.).



## Safety is a matter of training

Training is an essential part of any safety programme. The employer is responsible for ensuring that any person working at height is fully informed with regards to the correct use of PPE and systems.

Training will guarantee that the worker is safe and at ease in their working environment and therefore more productive.

Bacou-Daloz considers training to be a central part of their global fall protection offer and have a

complete range of courses and seminars to meet all of your requirements.



### Training courses cover:

- Working at height
- Rescue
- Expert assessment
- Equipment inspection



### What can you expect from us?

- Qualified instructors
- Clearly structured training concepts
- Training appropriate to the place of work
- Manufacturer-independent training
- Personal certificate for every participant
- Training on your premises is also possible



# Söll

fall-protection.com

**Bacou-Daloz –  
Söll Fall Protection Systems**

Christian Daloz Holding  
Deutschland  
GmbH & Co. KG  
Seligenweg 10  
D-95028 Hof  
Tel.: +49 9281 8302-0  
Fax : +49 9281 3626  
Email: soell@bacou-daloz.com  
www.fall-protection.com

**Bacou-Daloz –  
Söll Fall Protection Systems**

Osborn Way  
Hook  
Hampshire RG27 9HX  
United Kingdom  
Tel.: 00 44 (0) 1256 693200  
Fax: 00 44 (0) 1256 693300

**Bacou-Daloz  
Miller/FAS Engineering Services**

1345 15th Street  
Franklin  
PA 16323  
USA  
Tel.: 001 (800) 325 6746  
Fax: 001 (800) 892 4078  
soll@bacou-daloz.com

**Bacou-Daloz**

3 Walker St  
Braeside Victoria 3195  
Australia  
Australia Phone: 00 61 1300 139 166  
New Zealand Phone: 00 64 0800 322 200

**Bacou-Daloz  
Soll Italian Office**

Via Palestro, 1  
28100 Novara  
Italia  
Telefono: +39 02 38 59 9312  
Faximile: +39 02 94 19 5017

