

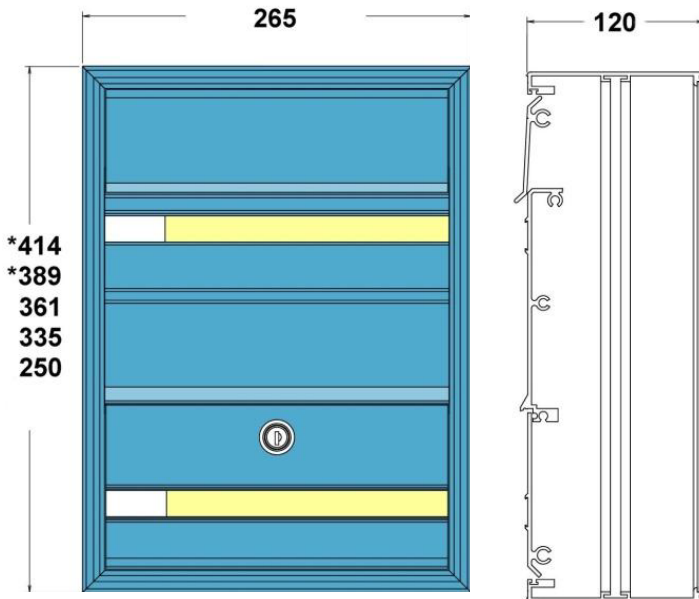

Introducing the COM 1 (389) Mailbox, Suitable for A4 sized flexible mail for face entry and retrieval – Manufactured from aluminium extrusion and polyester powder coated to a choice of RAL colours from our standard range. Suitable for wall mounting, wall recessing and has a freestanding option and can be banked/configured to meet most site conditions. Conforms to EN 13724. This high specification mailbox is manufactured from aluminium extrusion then polyester powder coated to a depth of 75/100 microns. (Sample tested to 1,200 hours salt-water spray). Each box fitted with a disc tumbler lock as standard – alloy die cast, bright chrome finish supplied with two keys per lock with up to 2,000 key differs, master suited.



This classically styled versatile unit combines delicate features with immense strength.

- Width: 265mm
- Height: 250mm | 335mm | 361mm | 389mm | 414mm
- Depth: 120mm
- Manufactured from aluminium extrusion, 2.5mm thick at its thinnest.
- Polyester powder coated to a choice of colours
- Suitable for domestic use
- For interior and exterior application
- Single unit weight 4.5k
- Can be produced to your exact size requirements
- Can be manufactured and supplied as singles, doubles or triples in the vertical plane
- Square corners suitable for recessing into brickwork or stud partition walls
- Weather and vandal resistant
- Aperture size:
 - 235x44mm = 414 high - will accept A4
 - 235x32mm = 389 high - will accept A4
 - 235x32mm = 250 high - C5 only



Installation Options (installation options cannot be applied on all models)

FREE STANDING
(SUPPORT LEGS)

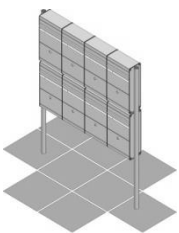

FREE STANDING
(SUPPORT TABLE)

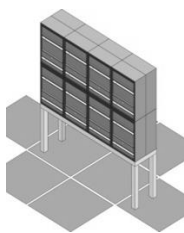

RECESSED OR
WALL MOUNTED

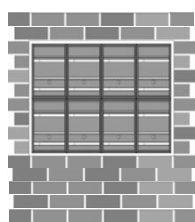

THROUGH THE
WALL

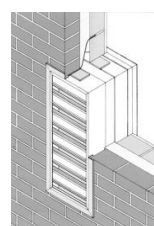

WITH DOOR
ENTRY SYSTEM

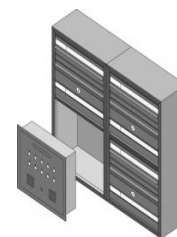

BESPOKE
ARRANGEMENT

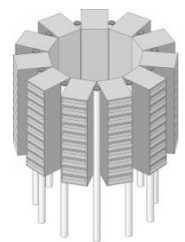



Introducing the EuroBox®, Suitable for A4 sized flexible mail for face entry and retrieval – Manufactured from Zintec steel and polyester powder coated to a choice of RAL colours from our standard range. Suitable for wall mounting. Conforms to EN 13724. The EuroBox® is manufactured from Zintec steel to BS EN 10142/ 10143 then polyester powder coated to a depth of 75/100 microns. (Sample tested to 1,200 hours salt-water spray). Each box complete with drilling template and fitting instructions. The EuroBox® comes complete with self-adhesive name case, but also has the option of high quality vinyl numbering.

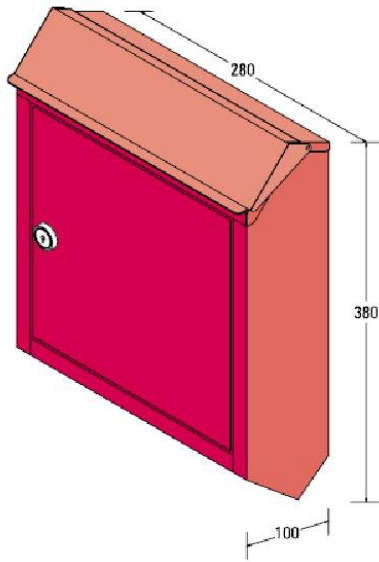

An attractive, high quality domestic mailbox.

- Width: 280mm
- Height: 380mm
- Depth: 100mm
- Manufactured from galvanised steel. Polyester powder coated to a choice of colours from our standard range
- Available in Stainless Steel option
- Suitable for domestic use
- For exterior application
- Supplied with fixings, drilling template and fitting instructions, plus a self-adhesive name case
- Fitted with a disc tumbler lock as standard
- Can be wall mounted or free standing
- Single unit weight 3.5k
- Recessed door for anti-leverage
- Weather and vandal resistant
- Aperture size 230mm x 30mm



Installation Options (installation options cannot be applied on all models)

FREE STANDING
(SUPPORT LEGS)

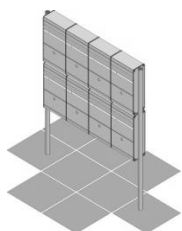

FREE STANDING
(SUPPORT TABLE)

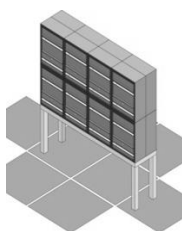

RECESSED OR
WALL MOUNTED

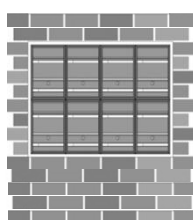

THROUGH THE
WALL

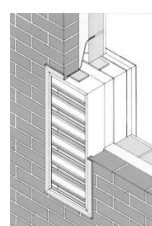

WITH DOOR
ENTRY SYSTEM

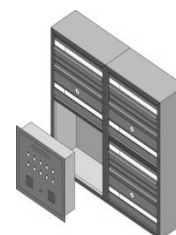

BESPOKE
ARRANGEMENT

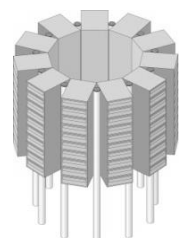



Introducing the Steel 1 Mailbox, Suitable for A4 sized flexible mail for face entry and retrieval – Manufactured from Zintec steel and polyester powder coated to a choice of RAL colours from our standard range. Suitable for wall mounting, wall recessing and has a freestanding option and can be banked/configured to meet most site conditions. Conforms to EN 13724. The Steel 1 is manufactured from Zintec steel to BS EN 10142 / 10143 then polyester powder coated to a depth of 75/100 microns. (Sample tested to 1,200 hours salt-water spray). Each box fitted with a disc tumbler lock as standard – alloy die cast, bright chrome finish supplied with two keys per lock with up to 2000 key differs, master suited.

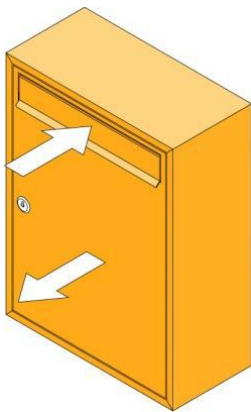
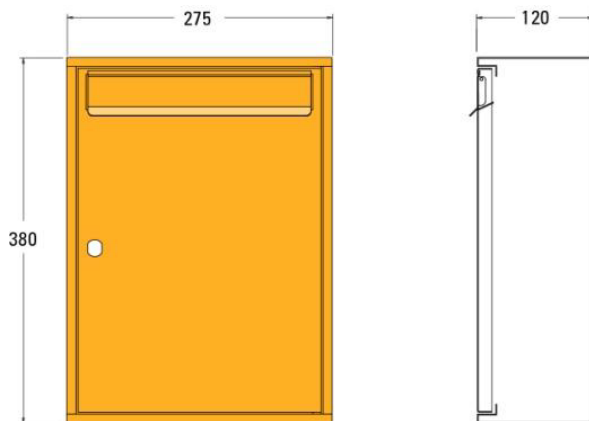

Designed and manufactured to offer exceptional quality for an economy product

- Width: 276mm
- Height: 380mm
- Depth: 120mm
- Manufactured from galvanised steel. Polyester powder coated to a choice of colours from our standard range
- Suitable for domestic and light commercial use
- For interior application or exterior with additional weather shielding
- Single unit weight: 3.5kg
- Manufactured as single units but can be factory banked
- Can be free standing, surface mounted or recessed
- Full sized steel door for full access
- Recessed door for anti leverage
- Weather resistant
- Vandal resistant
- Aperture size: 235mm x 30mm

Installation Options (installation options cannot be applied on all models)

FREE STANDING
(SUPPORT LEGS)

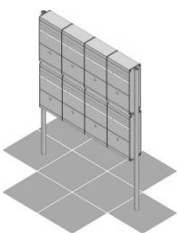

FREE STANDING
(SUPPORT TABLE)

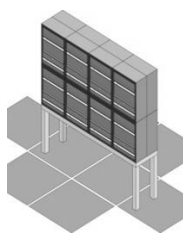

RECESSED OR
WALL MOUNTED

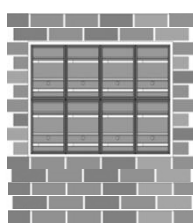

THROUGH THE
WALL

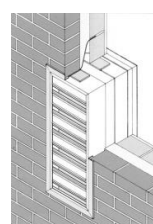

WITH DOOR
ENTRY SYSTEM

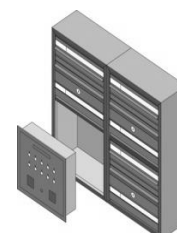

BESPOKE
ARRANGEMENT

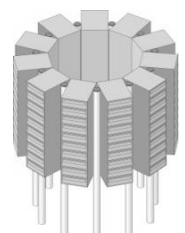



Introducing the COM2 Mailbox, Suitable for A4 sized flexible mail for face entry and retrieval – Manufactured from aluminium extrusion and polyester powder coated to a choice of RAL colours from our standard range. Suitable for wall recessing and has a freestanding option and can be banked/configured to meet most site conditions. Conforms to EN 13724. This high specification mailbox is polyester powder coated to a depth of 75/100 microns. (Sample tested to 1,200 hours salt-water spray). Each box fitted with a disc tumbler lock as standard – alloy die cast, bright chrome finish supplied with two keys per lock with up to 2,000 key differs, master suited.

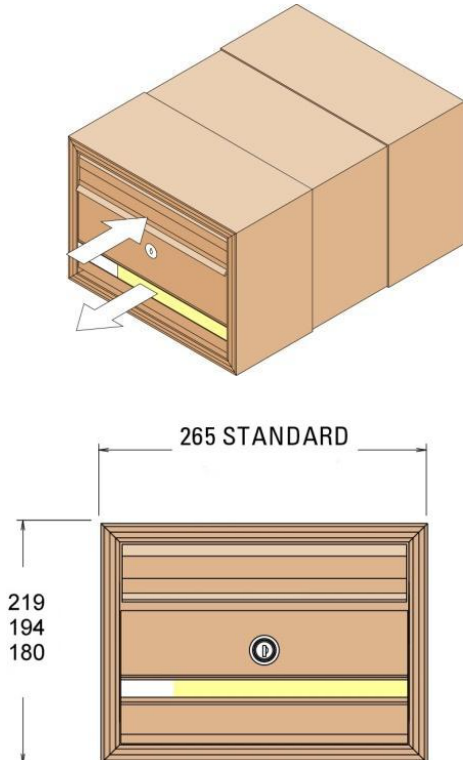

A high quality classically styled unit combines delicate features with immense strength.

- Width: 265mm
- Height: 180mm | 194mm | 219mm
- Depth: 360mm
- Manufactured from aluminium extrusion. Polyester powder coated to a choice of colours from our standard range
- Suitable for domestic and light commercial use
- For interior and exterior application
- Can be manufactured in vertical stacks up to 12 high
- Single unit weight 4kg
- Bottom hinged door
- Recessed and anti leverage door
- Square corners suitable for recessing into brickwork for stud partition wall
- Landscape option available
- Weather and vandal resistant
- Aperture size 235mm x 30mm
Larger models 235mm x 44mm



Installation Options (installation options cannot be applied on all models)

FREE STANDING
(SUPPORT LEGS)

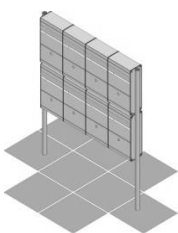

FREE STANDING
(SUPPORT TABLE)

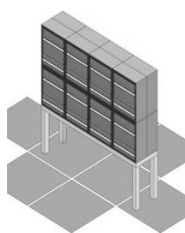

RECESSED OR
WALL MOUNTED

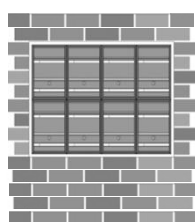

THROUGH THE
WALL

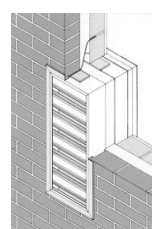

WITH DOOR
ENTRY SYSTEM

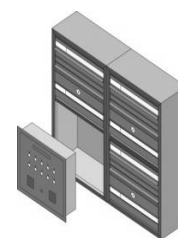

BESPOKE
ARRANGEMENT

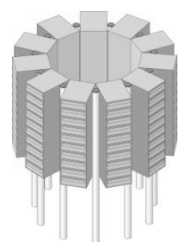

Datasheet

COM 2 – Steel Door

THE SAFETY
LETTERBOX
COMPANY LTD



Introducing the COM2 Steel Door Mailbox, Suitable for A4 sized flexible mail for face entry and retrieval – Manufactured from Aluminium Extrusion and polyester powder coated to a choice of RAL colours from our standard range. Suitable for wall recessing and has a freestanding option and can be banked/configured to meet most site conditions. Conforms to EN 13724. This high specification mailbox is polyester powder coated to a depth of 75/100 microns. (Sample tested to 1,200 hours salt-water spray). Each box fitted with a disc tumbler lock as standard – alloy die cast, bright chrome finish supplied with two keys per lock with up to 2,000 key differs, master suited.

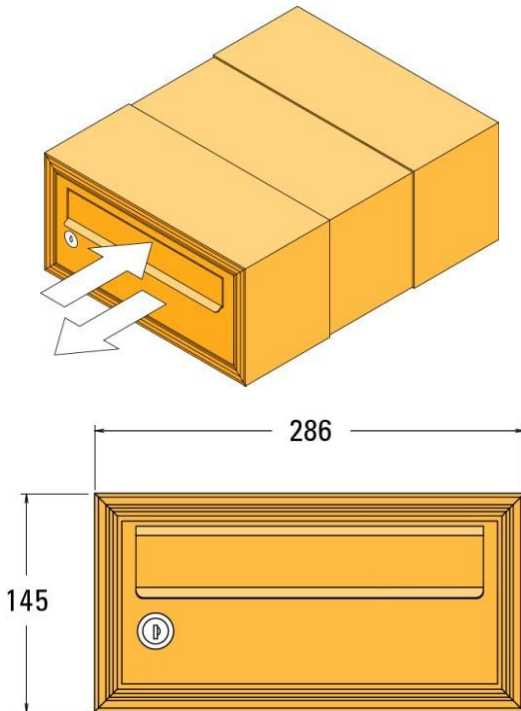

A high quality classically styled unit with an infinite range of sizes available for increased flexibility.

- Width: 286mm
- Height: 127mm | 145mm | 180mm | 219mm
- Depth: 360mm
- Manufactured from aluminium extrusion. Polyester powder coated to a choice of colours from our standard range
- Suitable for domestic and light commercial use
- For interior and exterior application
- Can be manufactured in vertical stacks up to 12 high
- Single unit weight 4kg
- Recessed and anti-leverage door
- Landscape option available
- Right hand hinged door
- Weather and vandal resistant
- Aperture size 235mm x 30mm

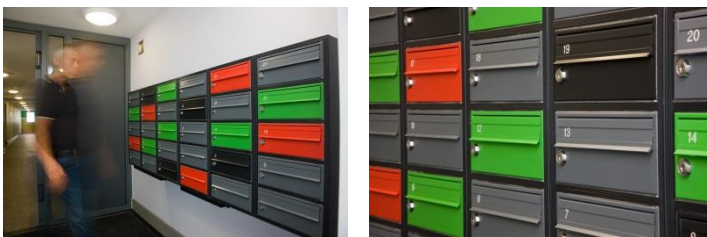

Installation Options (installation options cannot be applied on all models)

FREE STANDING
(SUPPORT LEGS)

FREE STANDING
(SUPPORT TABLE)

RECESSED OR
WALL MOUNTED

THROUGH THE
WALL

WITH DOOR
ENTRY SYSTEM

BESPOKE
ARRANGEMENT

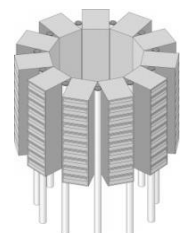
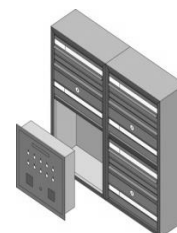
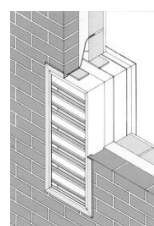
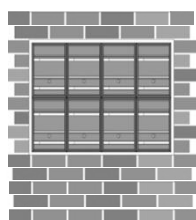
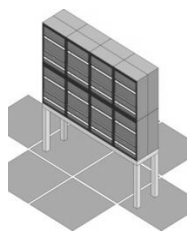
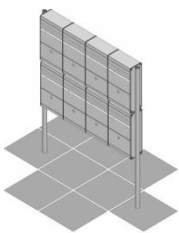

The Safety Letterbox Company Ltd
Unit 1B
Milland Industrial Estate
Milland Road
Neath SA11 1NJ UK



T: +44 (0) 1639 633525
F: +44 (0) 1639 646359

E: sales@safetyletterbox.com
www.safetyletterbox.com

Datasheet

Steel Door

THE SAFETY
LETTERBOX
COMPANY LTD



Introducing the Steel 2 Mailbox, Suitable for A4 sized mail for face entry and retrieval – Manufactured from Zintec steel and polyester powder coated to a choice of RAL colours. Suitable for wall mounting, wall recessing and has a freestanding option and can be banked/configured to meet most site conditions. Conforms to EN 13724. The Steel 2 is manufactured from zinc coated steel to BS EN 10142 / 10143 then polyester powder coated to a depth of 75/100 microns. (Sample tested to 1,200 hours salt-water spray). Each box fitted with a disc tumbler lock as standard – alloy die cast, bright chrome finish supplied with two keys per lock with up to 2000 key differs, master suited.

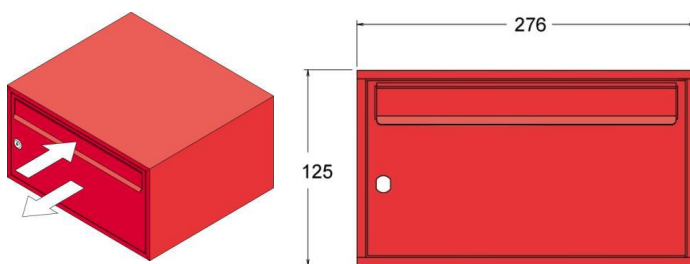

Designed and manufactured to offer exceptional quality for a budget product

- Width: 276mm
- Height: 125mm
- Depth: 360mm
- Manufactured from galvanised steel. Polyester powder coated to a choice of colours from our standard range
- Suitable for domestic and light commercial use
- For interior application or exterior with additional weather shielding
- Single unit weight: 3.5kg
- Manufactured as single units but can be factory banked
- Full sized steel door for full access
- Recessed door for anti leverage
- Landscape resistant
- Weather resistant
- Vandal resistant
- Aperture size: 235mm x 30mm

Installation Options (installation options cannot be applied on all models)

FREE STANDING
(SUPPORT LEGS)

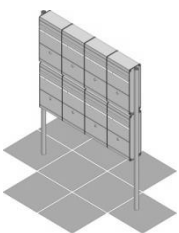

FREE STANDING
(SUPPORT TABLE)

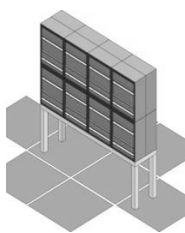

RECESSED OR
WALL MOUNTED

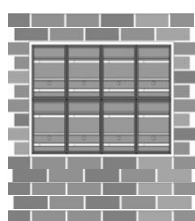

THROUGH THE
WALL

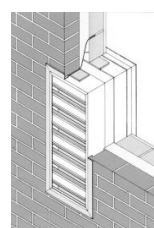

WITH DOOR
ENTRY SYSTEM

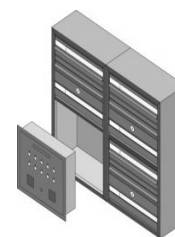

BESPOKE
ARRANGEMENT

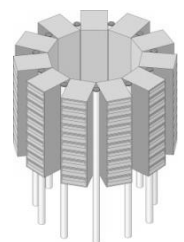



Introducing the H1 Mailbox, Suitable for A4 sized mail for face entry and retrieval – Manufactured from Galvanised steel and polyester powder coated to a choice of RAL colours from our standard range. Suitable for wall mounting, wall recessing and has a freestanding option and can be banked/configured to meet most site conditions. Conforms to EN 13724 The Steel 2 is manufactured from zinc coated steel to BS EN 10142 / 10143 then polyester powder coated to a depth of 75/100 microns. (Sample tested to 1,200 hours salt-water spray). Each box fitted with a disc tumbler lock as standard – alloy die cast, bright chrome finish supplied with two keys per lock, master suited.

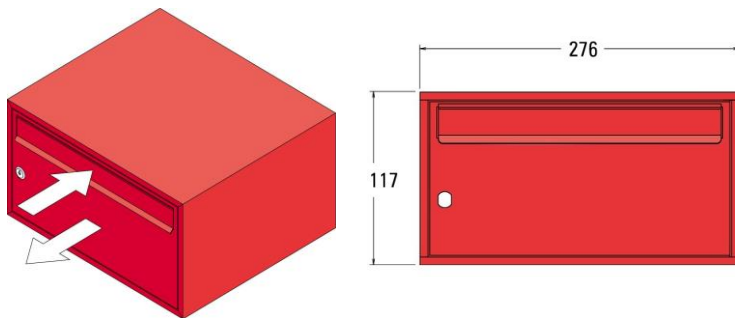

Designed and manufactured to offer exceptional quality for a budget product

- Width: 276mm
- Height: 117mm
- Depth: 360mm
- Manufactured from galvanised steel. Polyester powder coated to a choice of colours from our standard range
- Suitable for domestic and light commercial use
- For interior application or exterior with additional weather shielding
- Single unit weight 3.0 k
- Manufactured as single units or factory banked
- Full sized steel door for full access
- Recessed and anti leverage door
- Landscape option available
- Weather resistant
- Vandal resistant
- Aperture size 235mm x 30mm

Installation Options (installation options cannot be applied on all models)

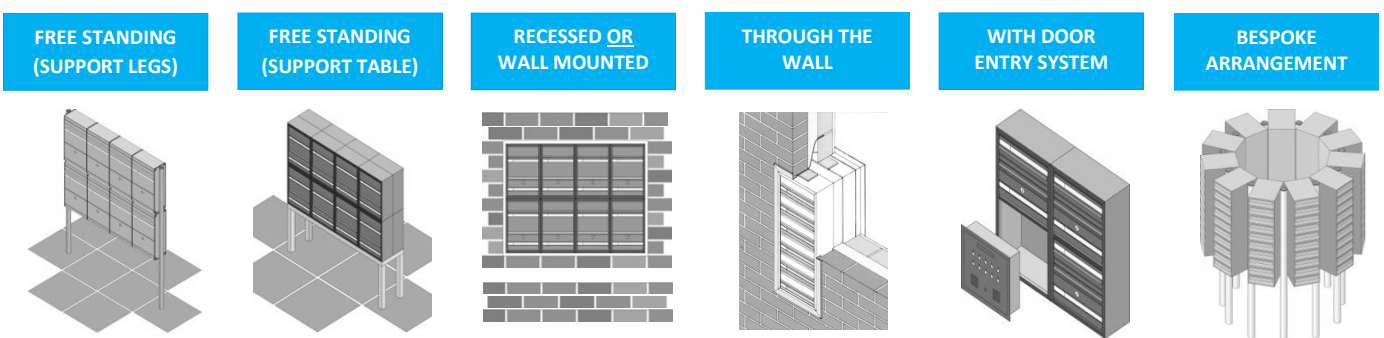

Datasheet

COM 3 Domestic

THE SAFETY
LETTERBOX
COMPANY LTD



Introducing the COM 3 Mailbox, Suitable for A4 sized mail for face entry and rear retrieval – Manufactured from aluminium extrusion and polyester powder coated to a choice of RAL colours from our standard range. Suitable for wall & panel recessing and can be banked/configured to meet most site conditions. Conforms to EN 13724. This high specification mailbox is manufactured from Aluminium extrusion & Zinc Coated Steel then polyester powder coated to a depth of 75/100 microns. (Sample tested to 1,200 hours salt-water spray). Each box fitted with a disc tumbler lock as standard – alloy die cast, bright chrome finish supplied with two keys per lock with up to 2,000 key differs, master suited.

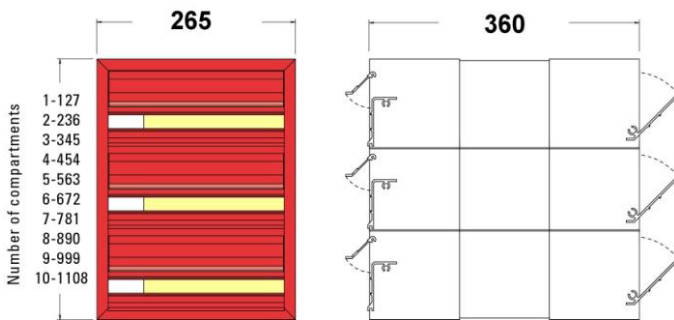
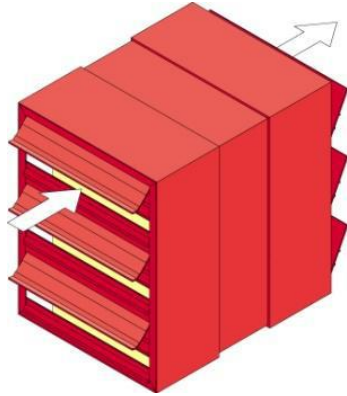

A useful and installation friendly unit as it is manufactured in a single cabinet which contains a number of compartments as requested by the client. Easy to install on site as it is delivered in a completed state.

- Width: 265mm
- Height: 127mm
- Depth: 360mm
- Manufactured from aluminium extrusion. Polyester powder coated to a choice of colours from our standard range
- Suitable for domestic use
- Single unit weight 3k
- Range of standard sizes available
- Accepts A4 mail
- Can be manufactured in vertical stacks up to 10 high
- Suitable for through wall or panel or window frame
- Lockable – complete with two keys
- Can hold door entry or video equipment
- Weather, fire and vandal resistant
- Aperture size 235mm x 30mm

Installation Options (installation options cannot be applied on all models)

FREE STANDING
(SUPPORT LEGS)

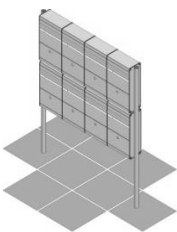

FREE STANDING
(SUPPORT TABLE)

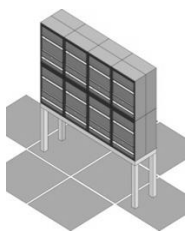

RECESSED OR
WALL MOUNTED

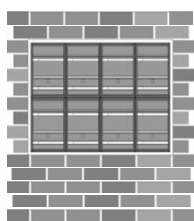

THROUGH THE
WALL

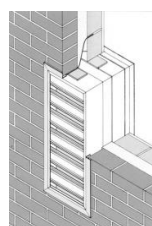

WITH DOOR
ENTRY SYSTEM

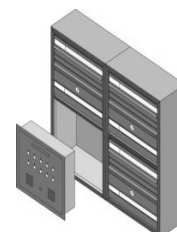

BESPOKE
ARRANGEMENT

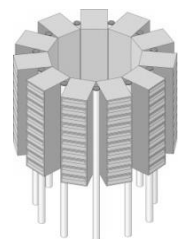

The Safety Letterbox Company Ltd
Unit 1B
Milland Industrial Estate
Milland Road
Neath SA11 1NJ UK



T: +44 (0) 1639 633525
F: +44 (0) 1639 646359

E: sales@safetyletterbox.com
www.safetyletterbox.com