

Cills



All standard cills are supplied with 100mm long stools; other lengths are available on request. Cills are manufactured to suit standard window openings; non-standard sizes can be made to order. These cills are suitable for installation into brickwork; cills suitable for rendered walls are detailed on page 13.

Please note that CDM Regulations may require some cills to be supplied in more than one piece. A Technical Data Sheet showing the correct installation for cills is available on request.

C2

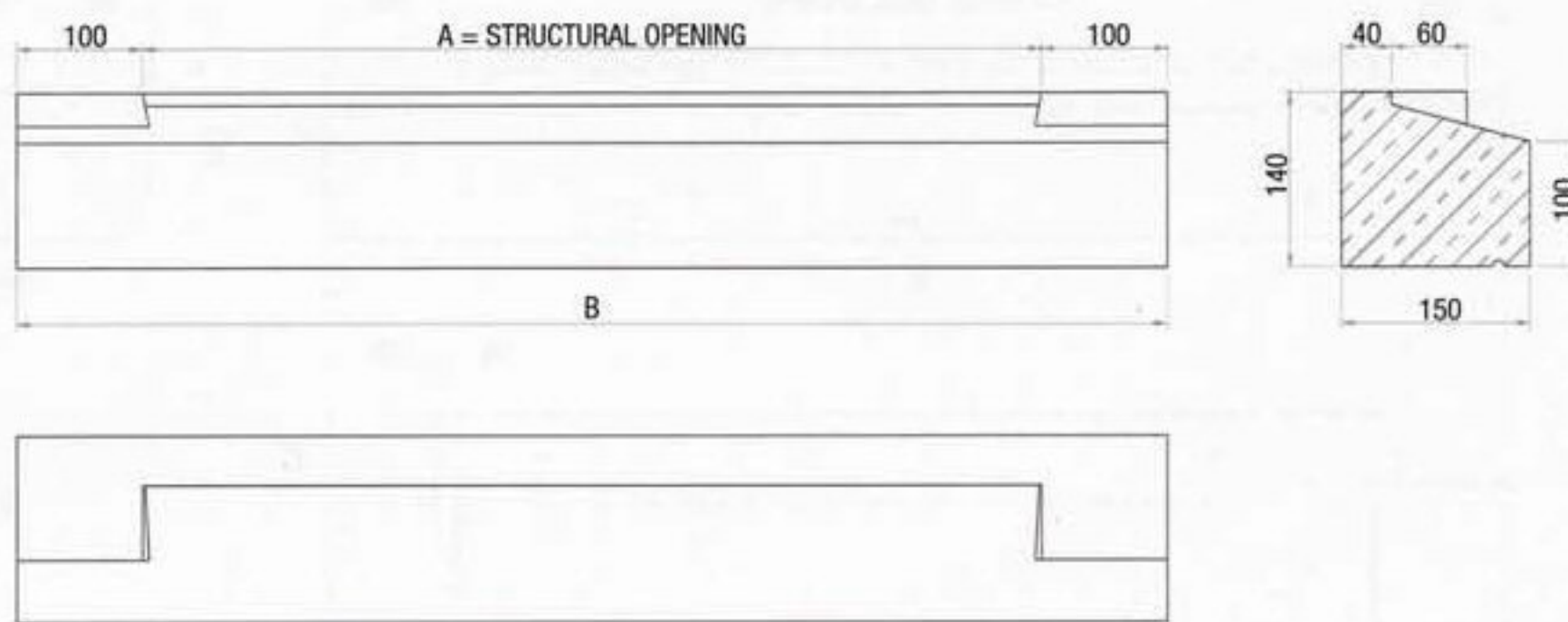

C3

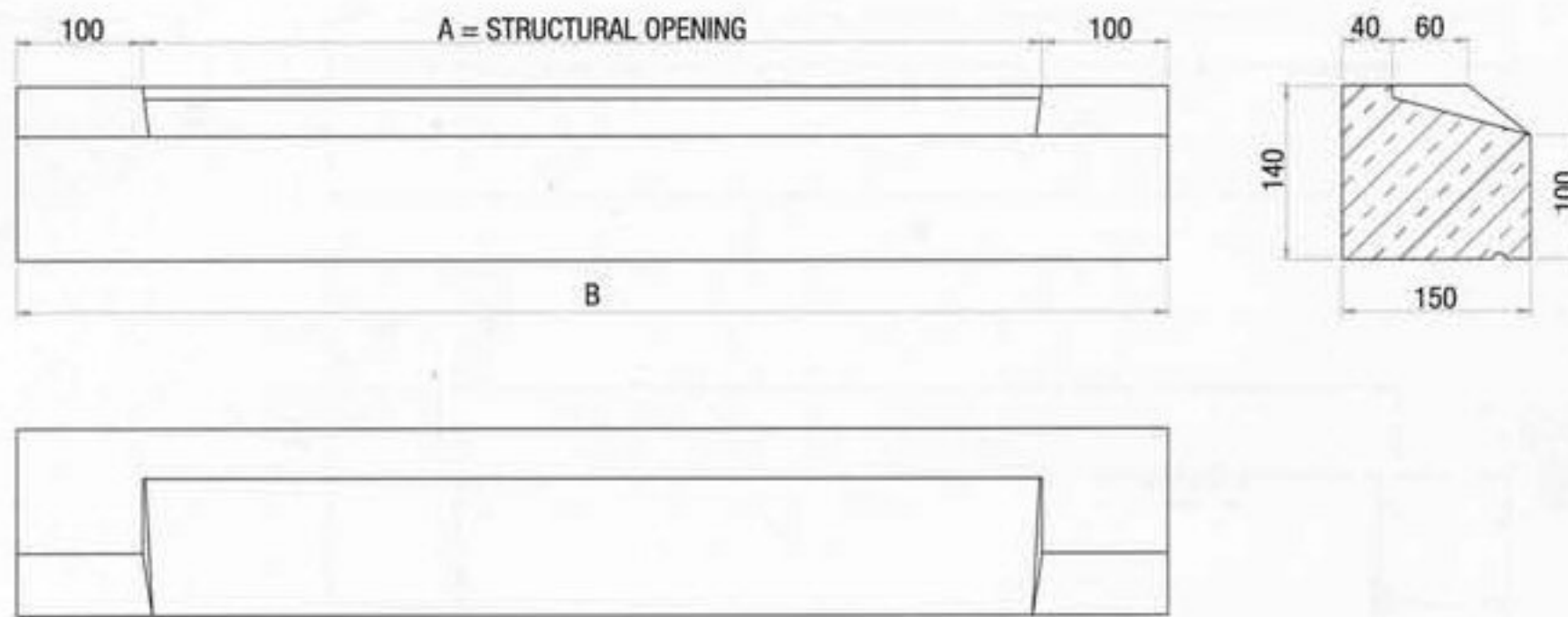

C13

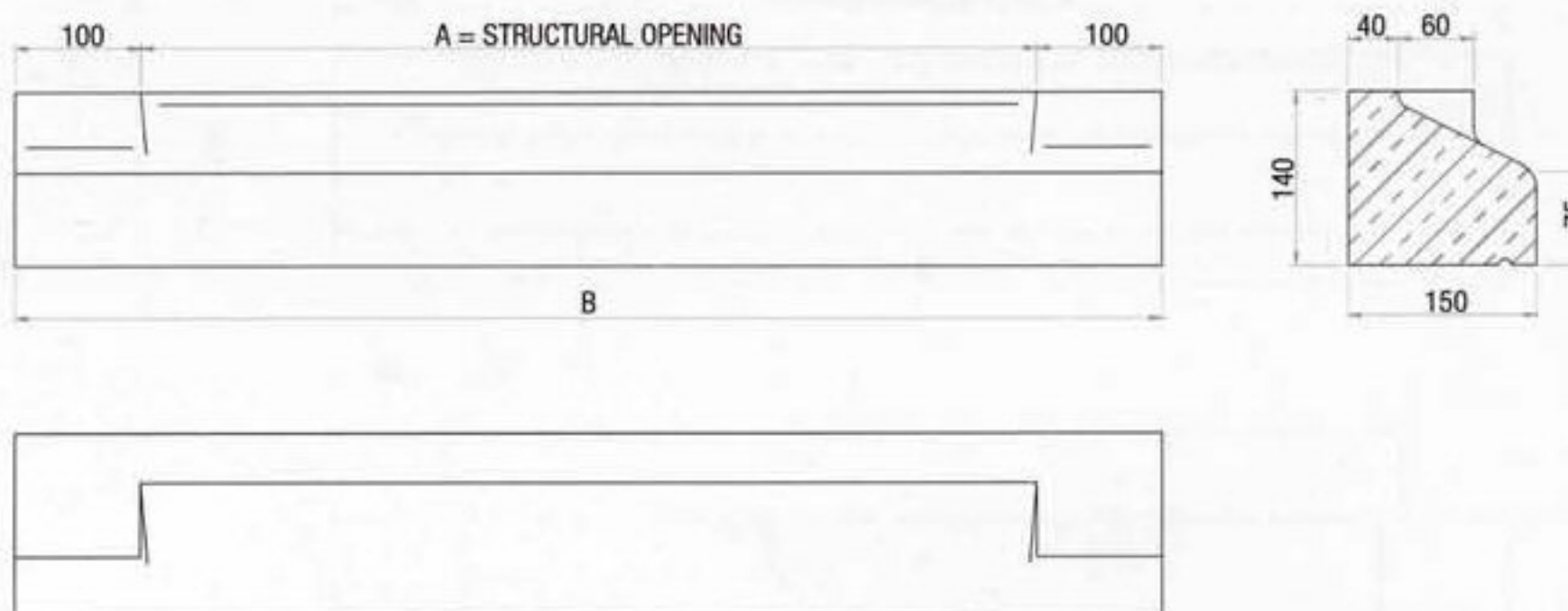



Cills

All standard cills are supplied with 100mm long stools; other lengths are available on request. Cills are manufactured to suit standard window openings; non-standard sizes can be made to order. These cills are suitable for installation into brickwork; cills suitable for rendered walls are detailed on page 13.

Please note that CDM Regulations may require some cills to be supplied in more than one piece. A Technical Data Sheet showing the recommended installation details for cills is available on request.

C14

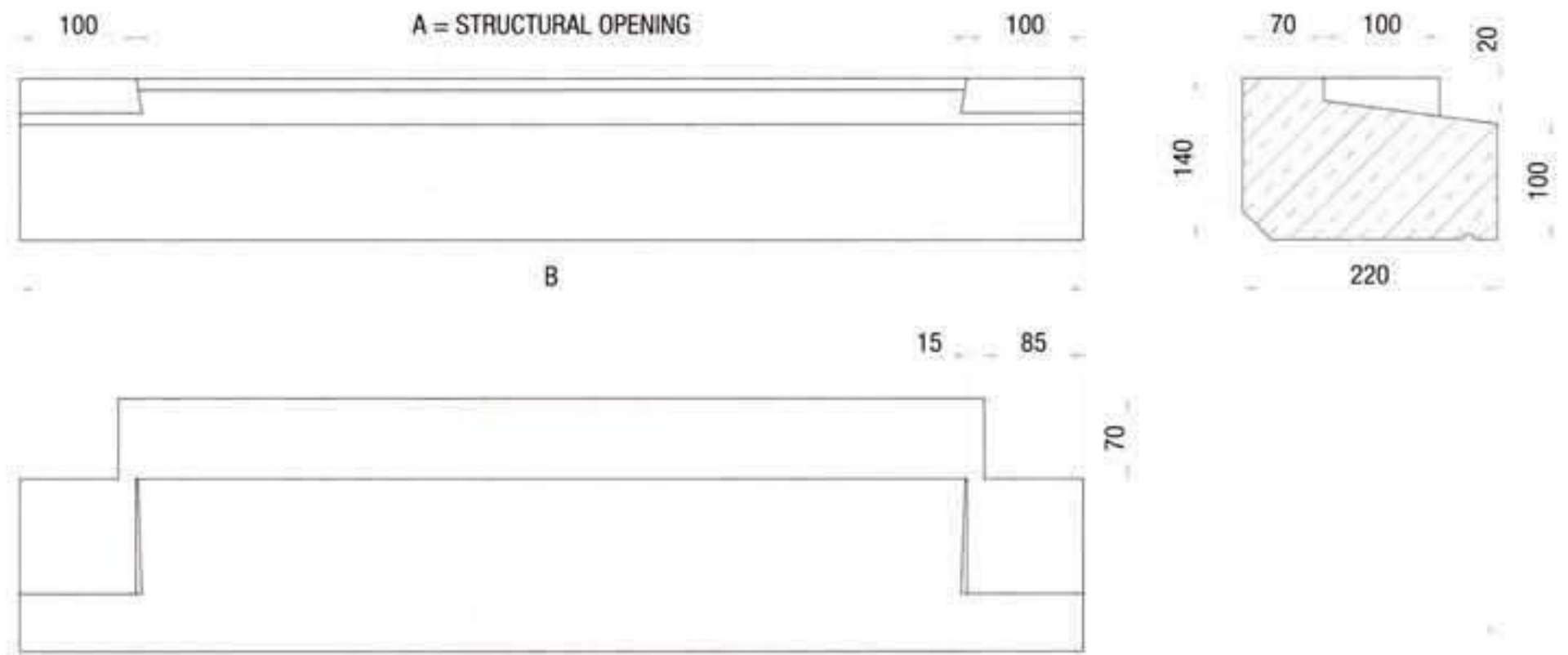

C15

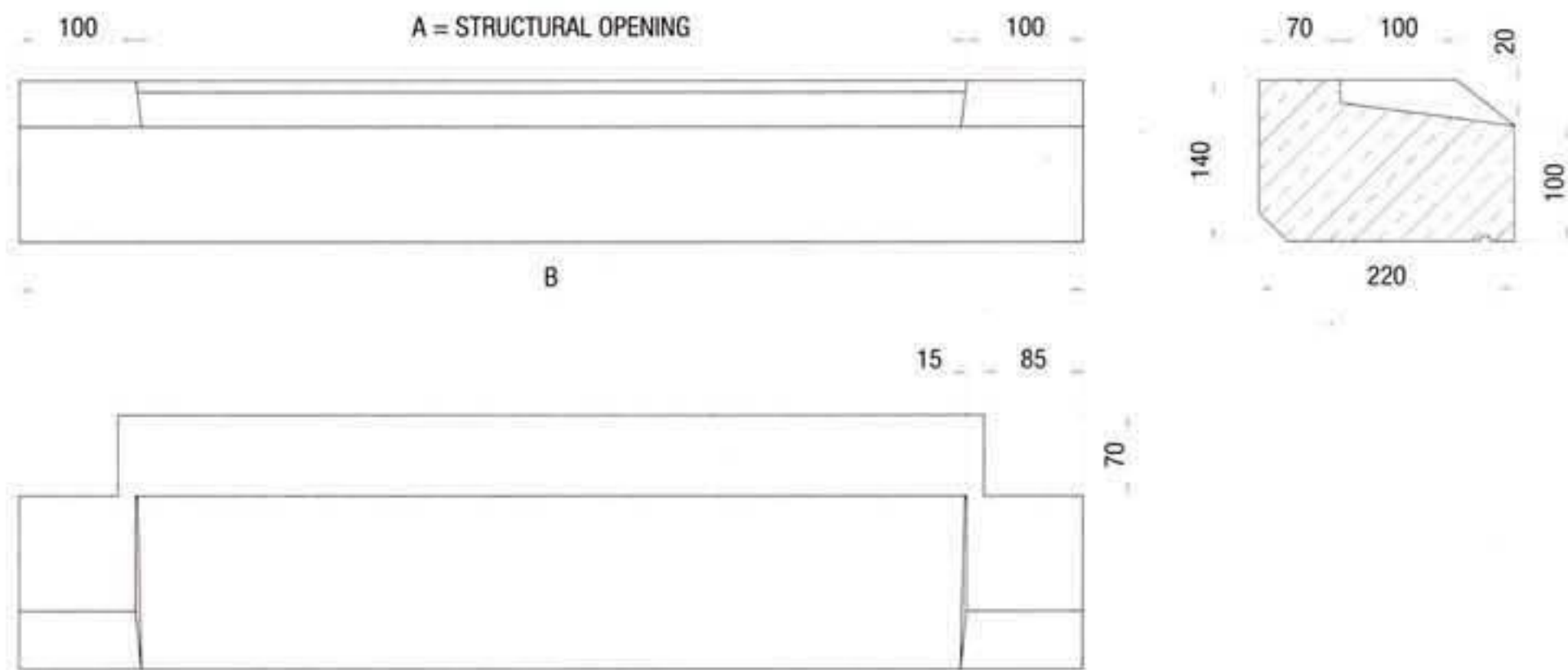

C16

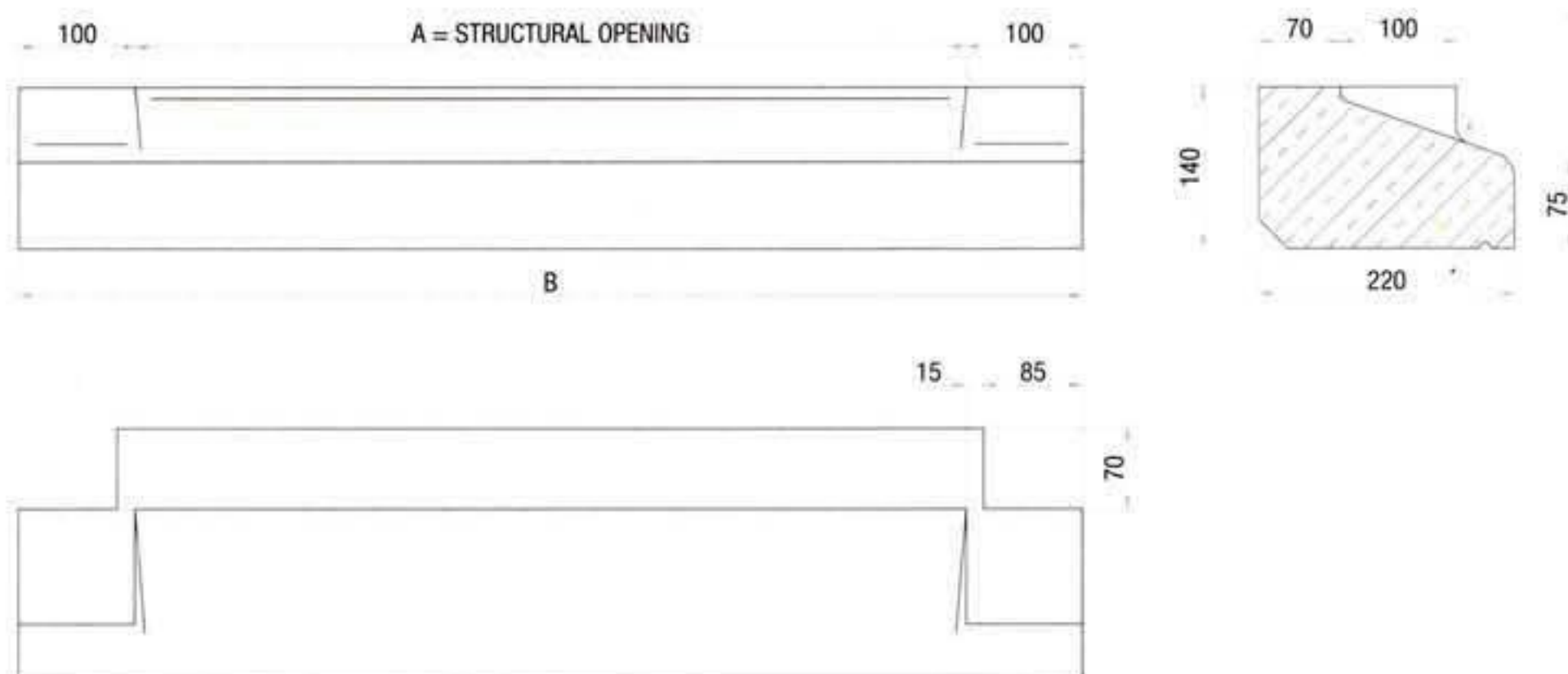

Cills



All standard cills are supplied with 100mm long stools; other lengths are available on request. Cills are manufactured to suit standard window openings; non-standard sizes can be made to order. These cills are suitable for installation into brickwork; cills suitable for rendered walls are detailed on page 13.

Please note that CDM Regulations may require some cills to be supplied in more than one piece. A Technical Data Sheet showing the correct installation for cills is available on request.

C5

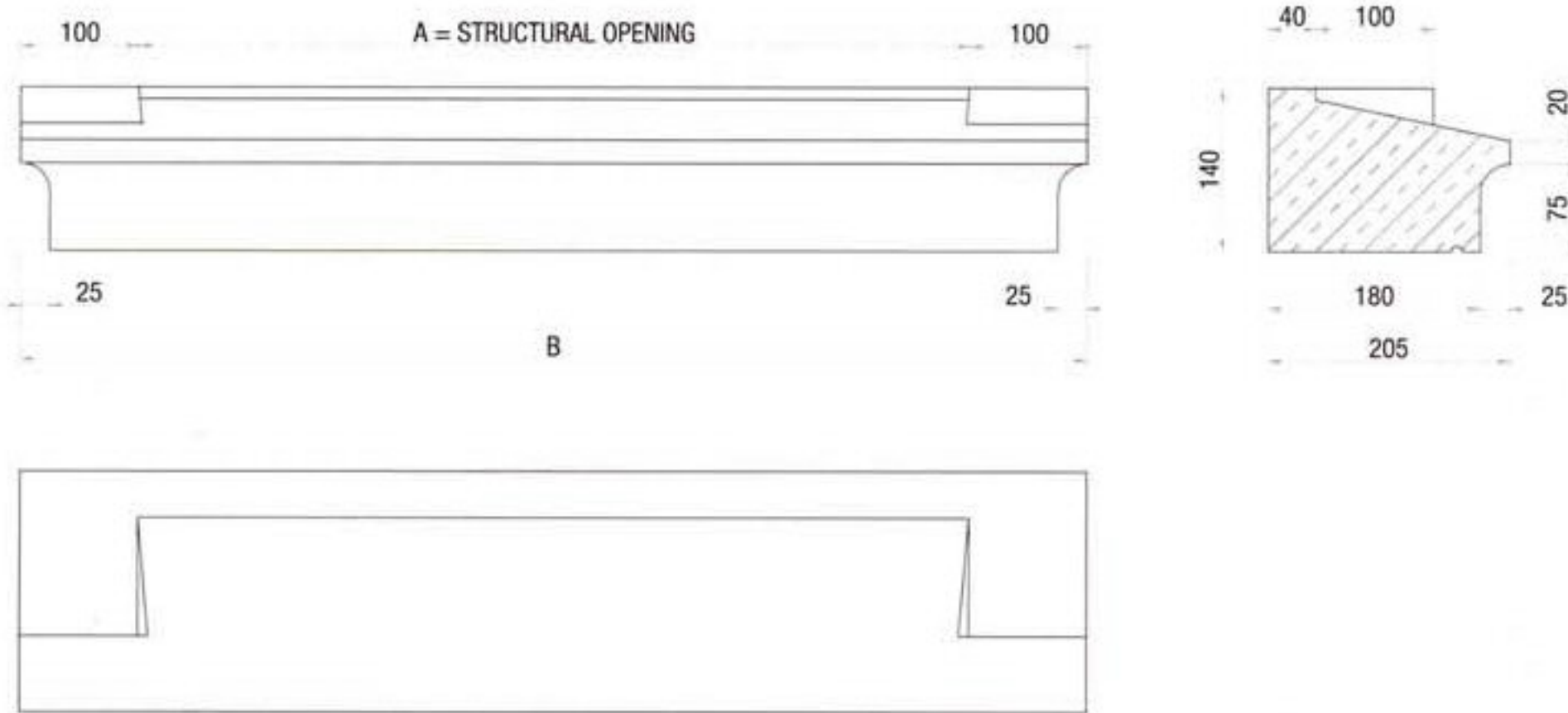

C6

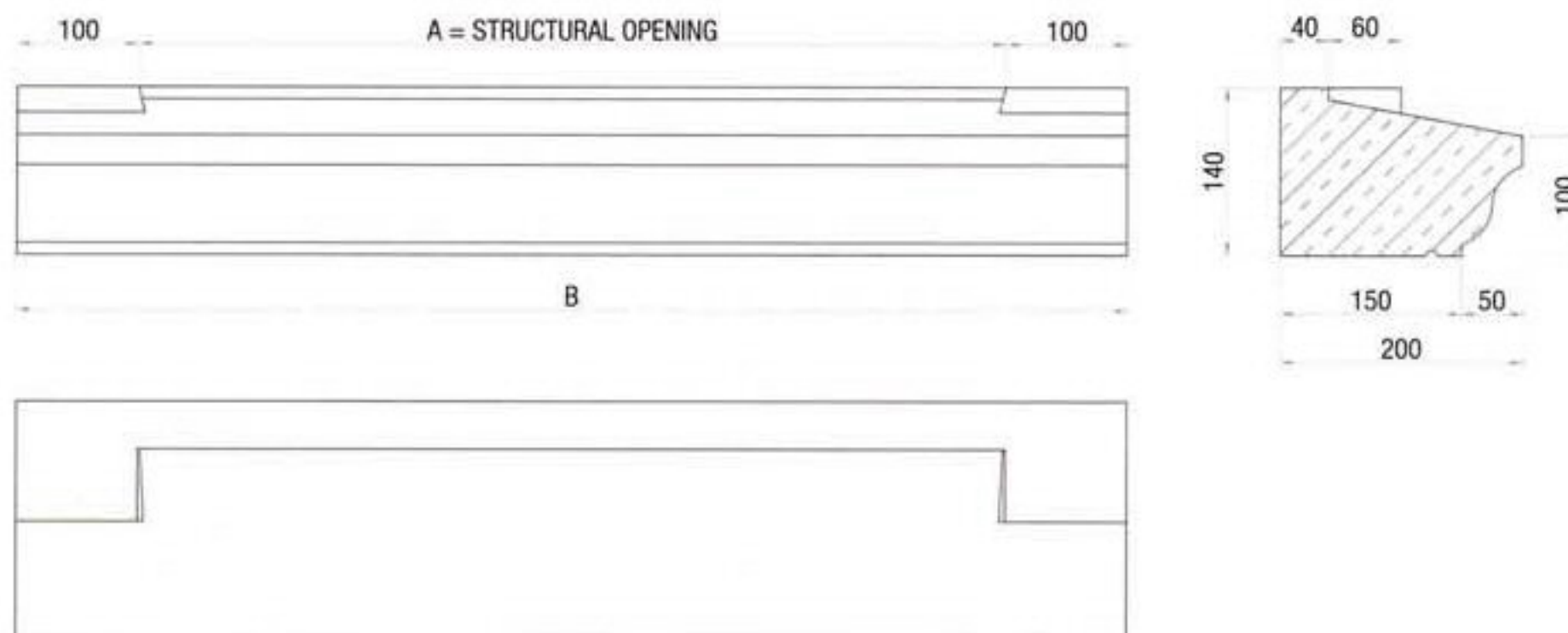

Cills



All standard cills are supplied with 100mm long stools; other lengths are available on request. Cills are manufactured to suit standard window openings; non-standard sizes can be made to order. These cills are suitable for installation into brickwork; cills suitable for rendered walls are detailed on page 13.

Please note that CDM Regulations may require some cills to be supplied in more than one piece. A Technical Data Sheet showing the correct installation for cills is available on request.

C7

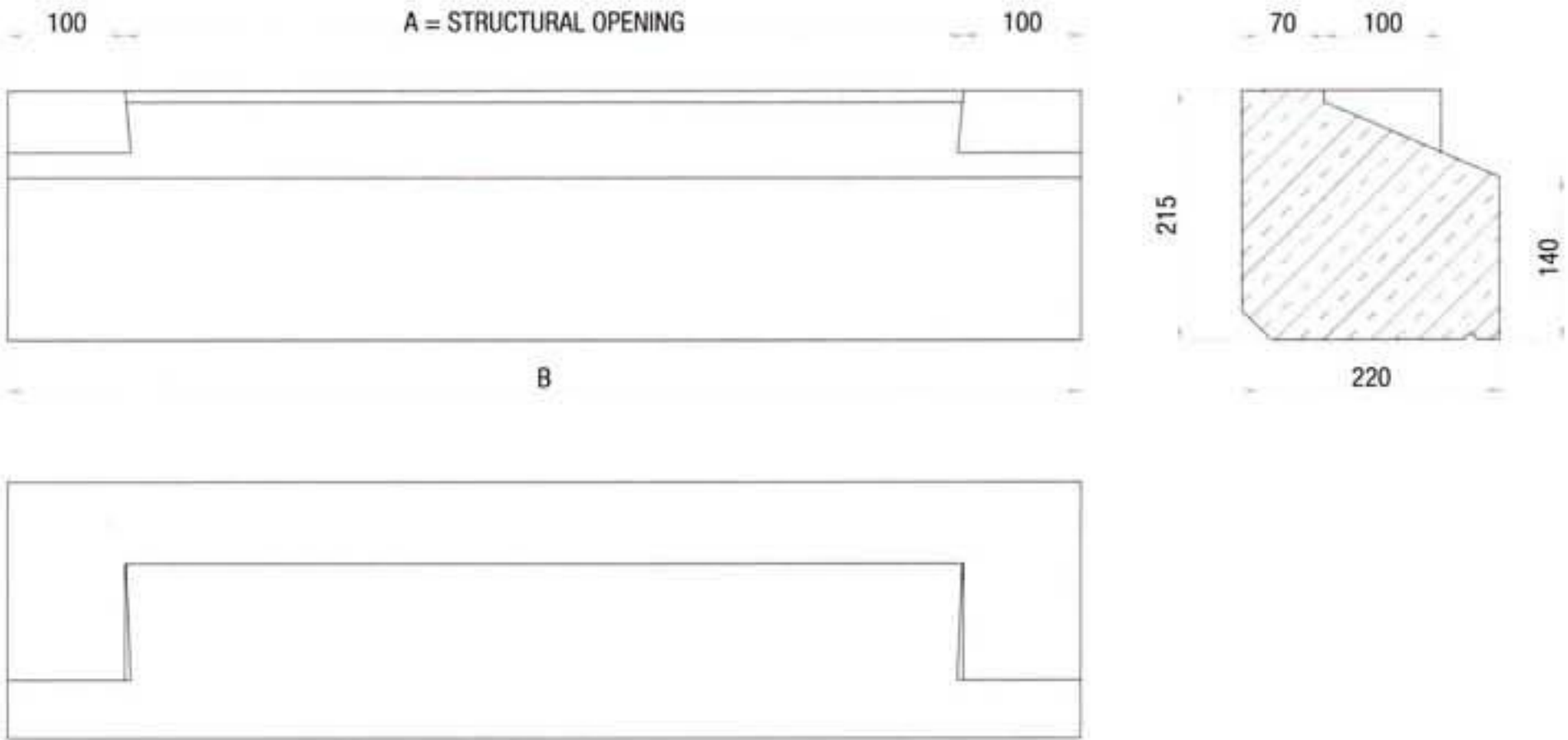

C8

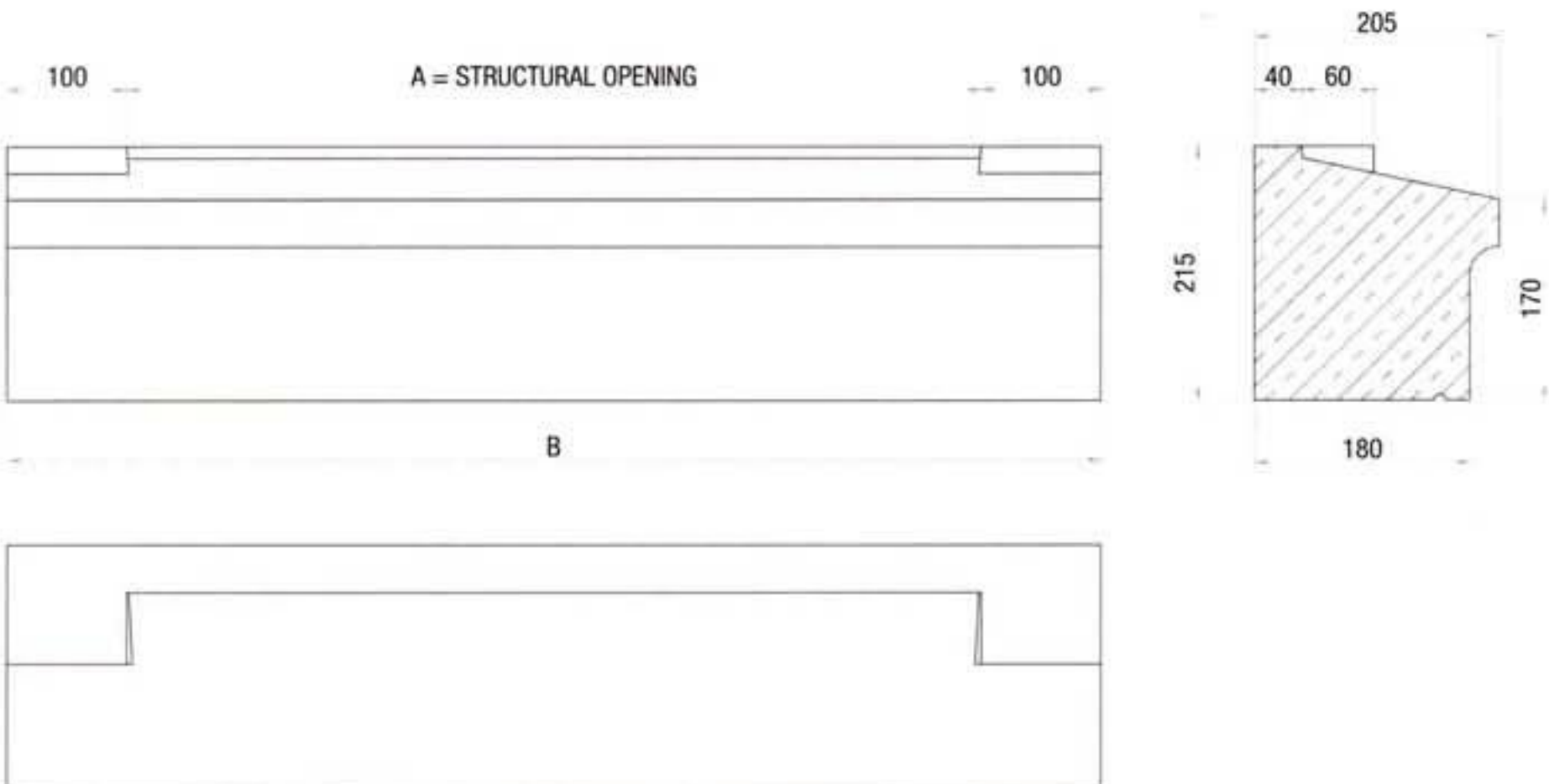

Cills

All standard cills are supplied with 100mm long stools; other lengths are available on request. Cills are manufactured to suit standard window openings; non-standard sizes can be made to order. These cills are suitable for installation into rendered walls.

Please note that CDM Regulations may require some cills to be supplied in more than one piece. A Technical Data Sheet showing the correct installation for cills is available on request.



CR2

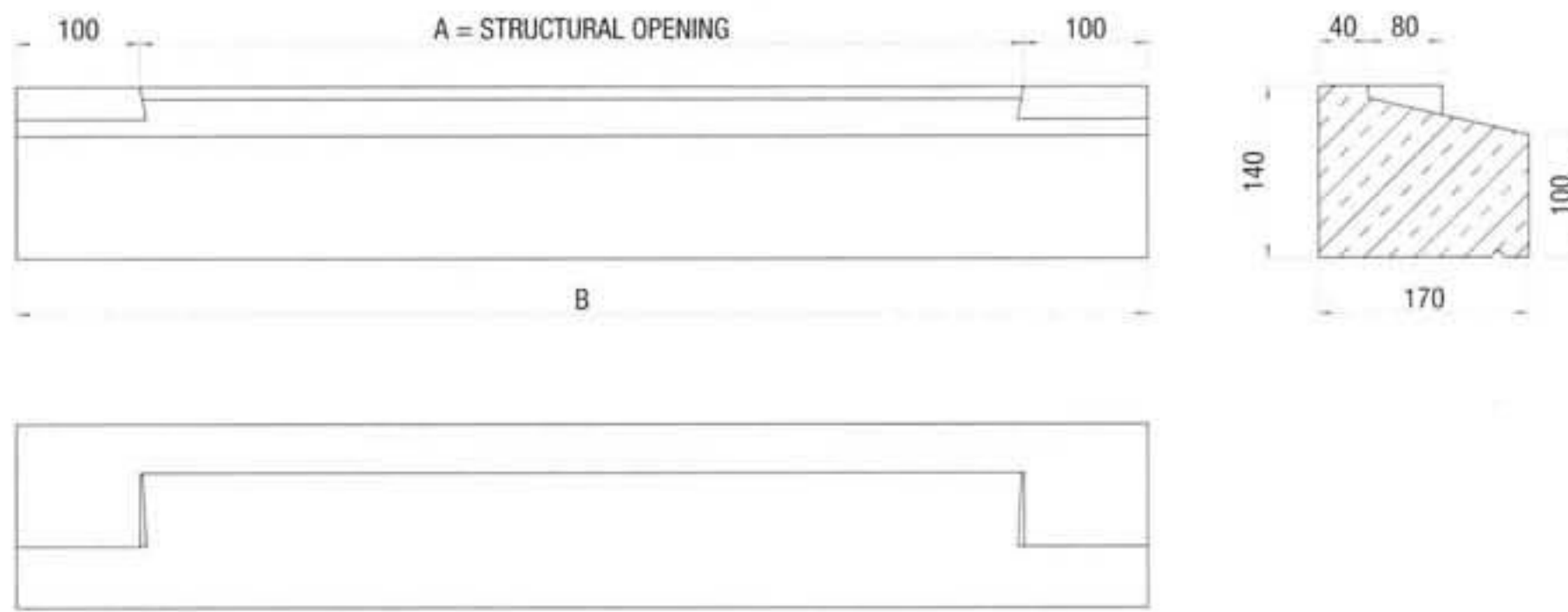

CR3

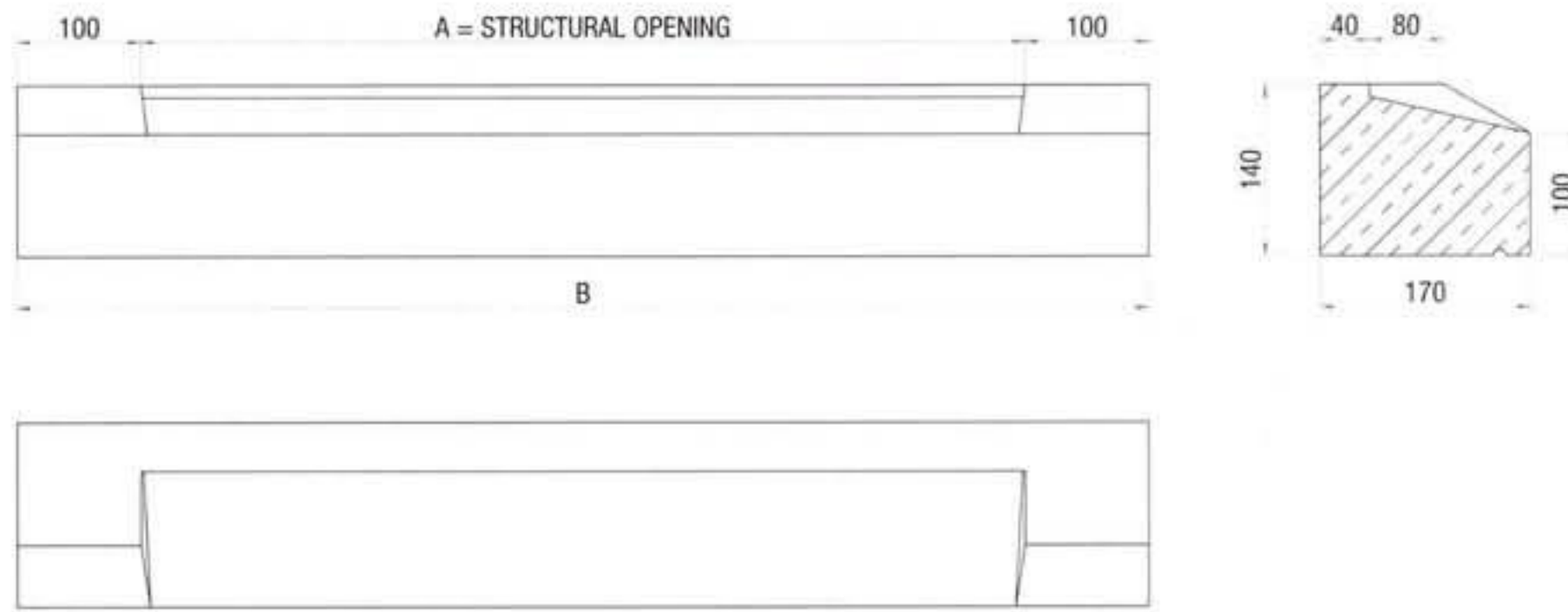

CR13

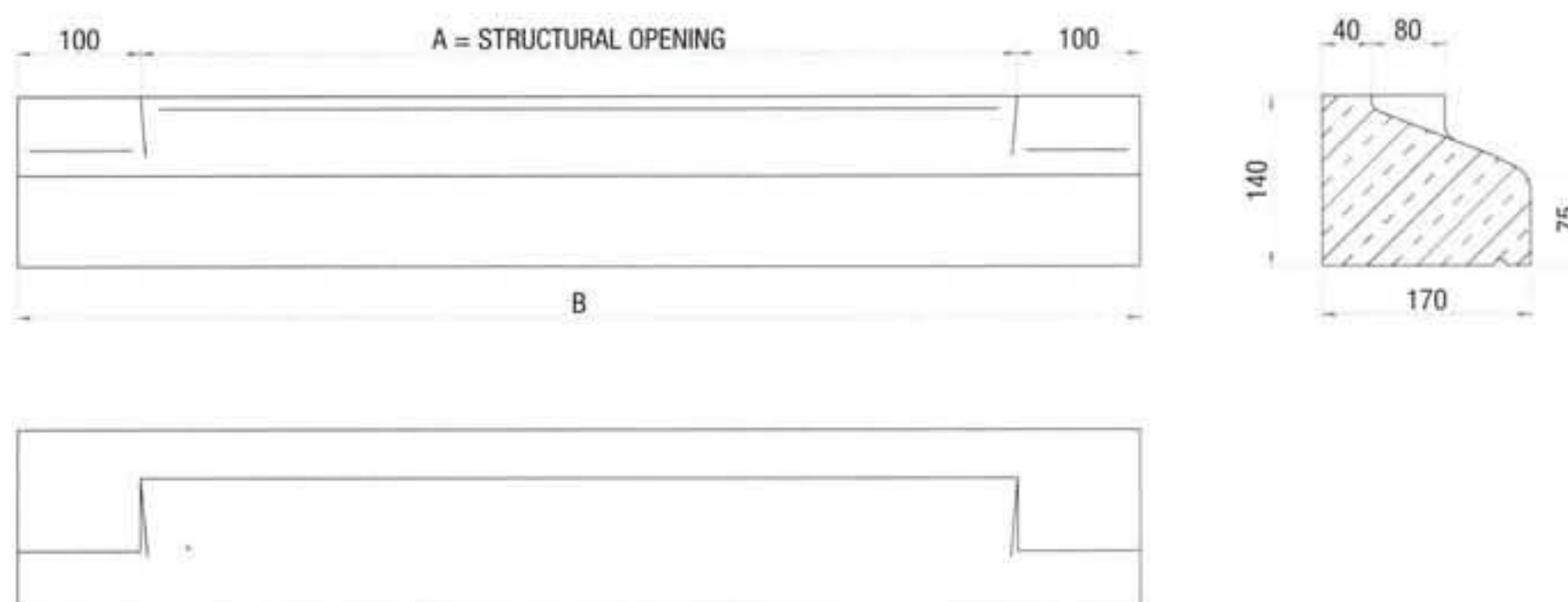



Slip Cills

Slip cills (i.e., no stools) can be provided for all profiles detailed on pages 9-13. A tolerance of 10mm should be allowed less than the structural opening.

SR
SL

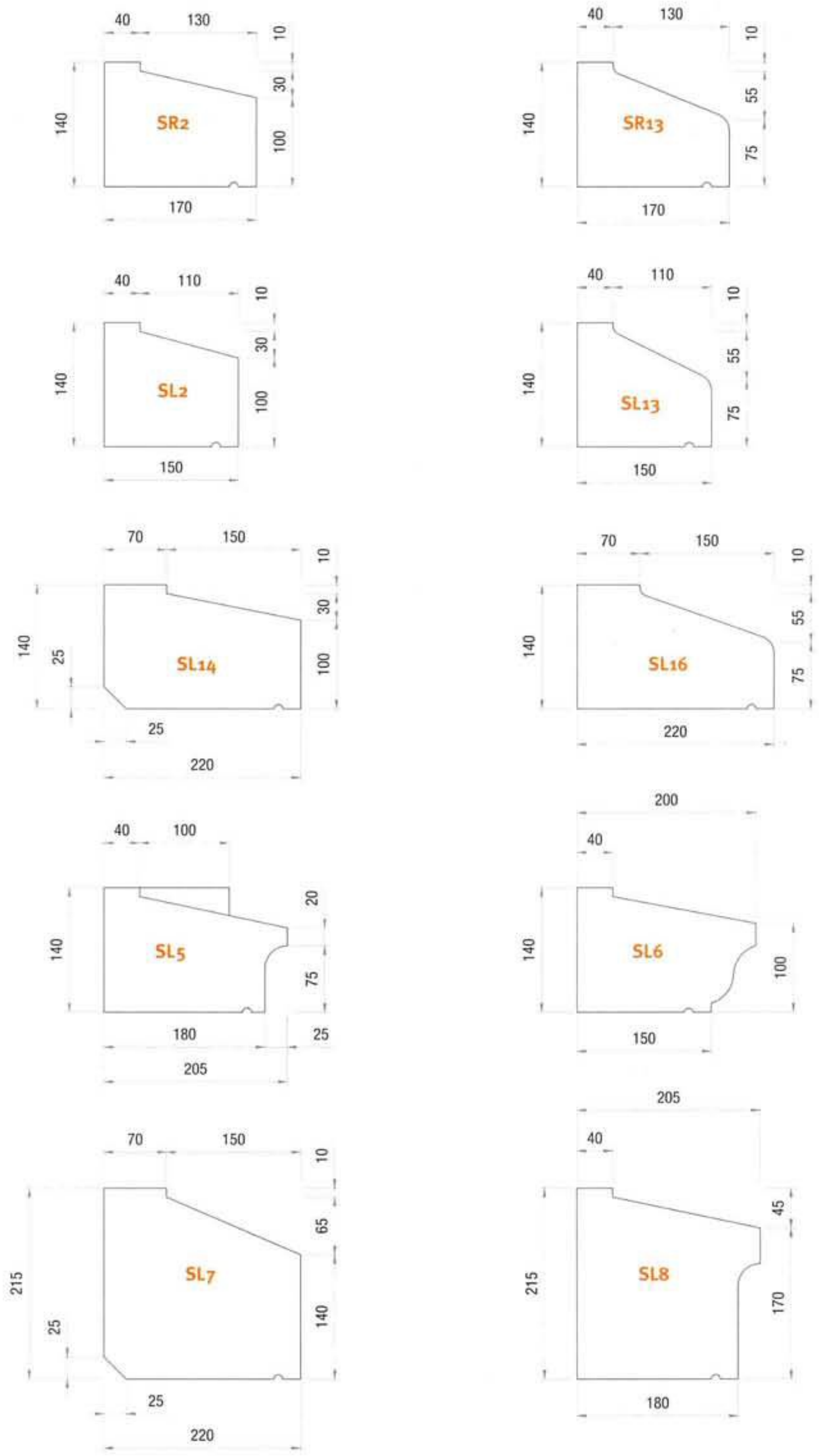

Bay Cills



Bay cills can be supplied for all profiles (pages 9-14). Please note that bays can only be manufactured when detailed drawings or brickwork templates have been supplied to us or our CAD department has supplied drawings for approval. This could have implications with extended lead times. Alternatively the units could be supplied oversize to cut on site to suit the finished brickwork dimensions.

The recommended joint size in perp joints is 10mm.

BY45

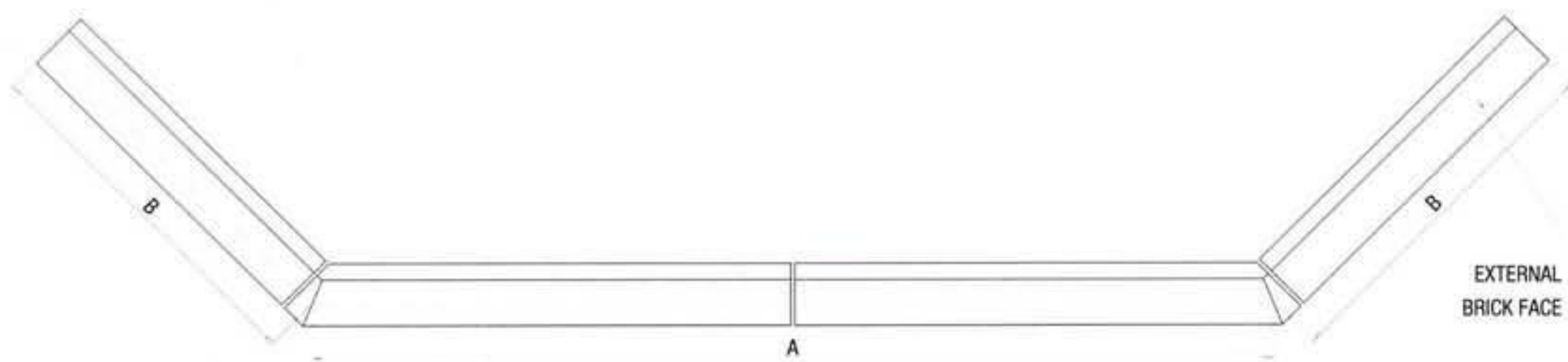

BY90

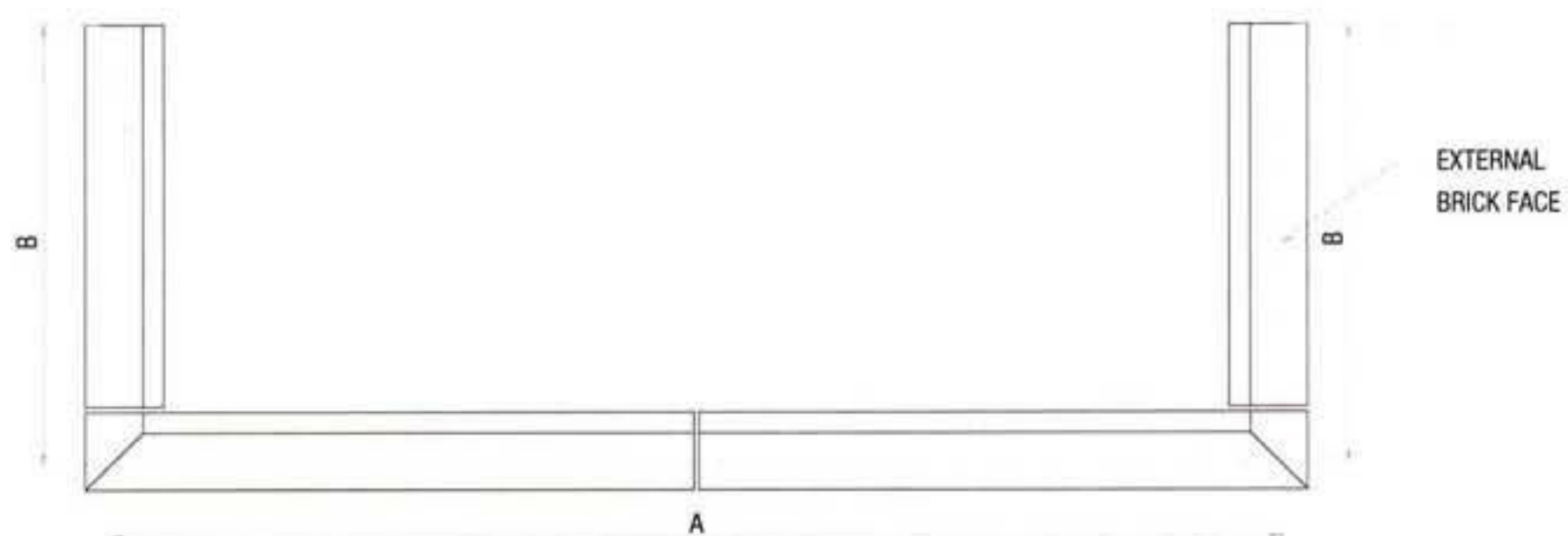

Window Surrounds



Any window surround can be manufactured to suit the height of the window. Please state height 'A' when placing the order. Jamb/mullions over 1500mm would be supplied in two pieces in line with the recommendations on slenderness ratios in BS 1217 : 1997. All window surrounds are supplied with stainless steel dovetail cramp fixings and dowels. A Technical Data Sheet showing the recommended fixing details of window surrounds is available on request. Sizes to suit standard window openings can also be supplied together with bay surrounds.

WS1

WS2

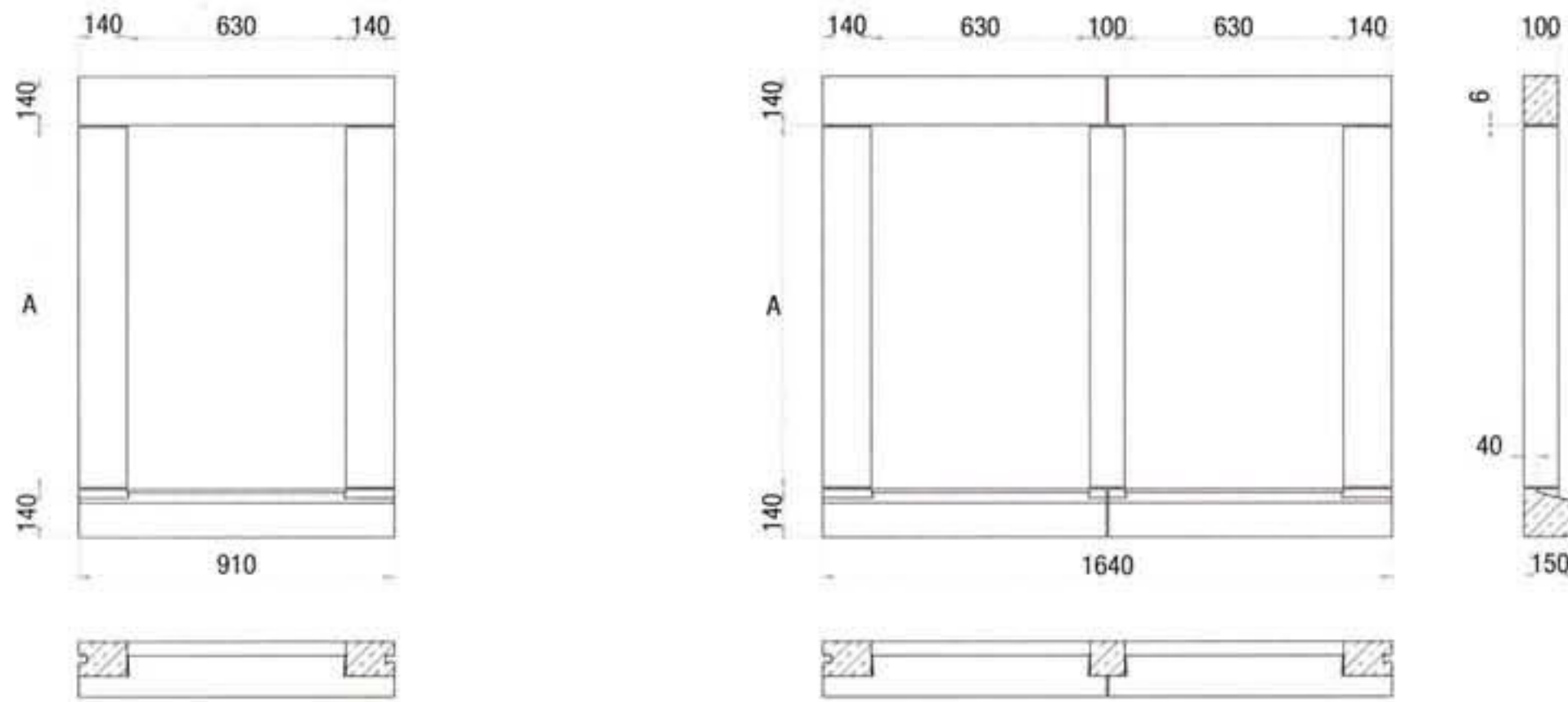

WS3

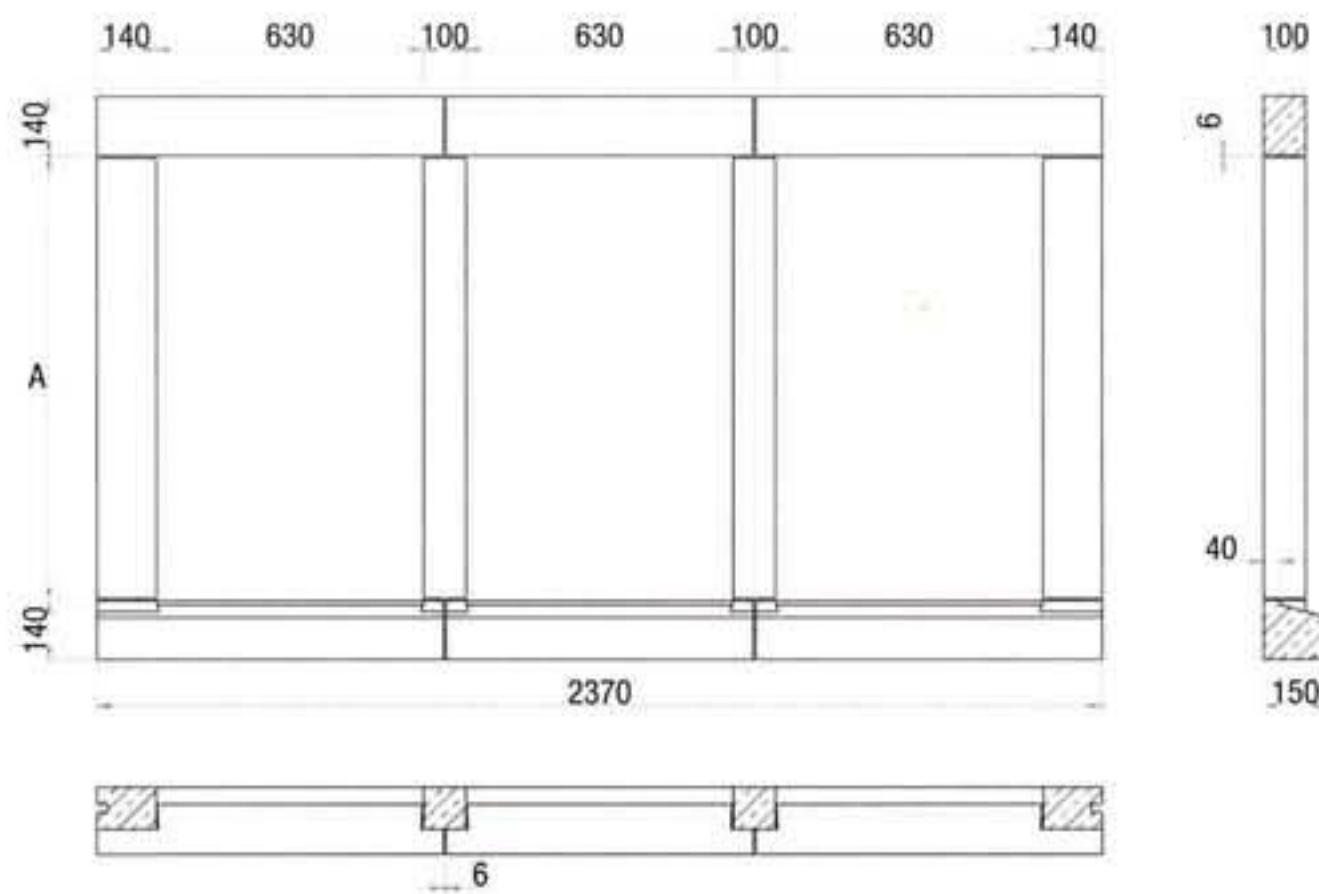



Window Surrounds

Any window surround can be manufactured to suit the height of the window. Please state height 'A' when placing the order. Jamb/mullions over 1500mm would be supplied in two pieces in line with the recommendations on slenderness ratios in BS 1217 : 1997. All window surrounds are supplied with stainless steel dovetail cramp fixings and dowels. A Technical Data Sheet showing the recommended fixing details of window surrounds is available on request. Sizes to suit standard window openings can also be supplied together with bay surrounds.

WS4

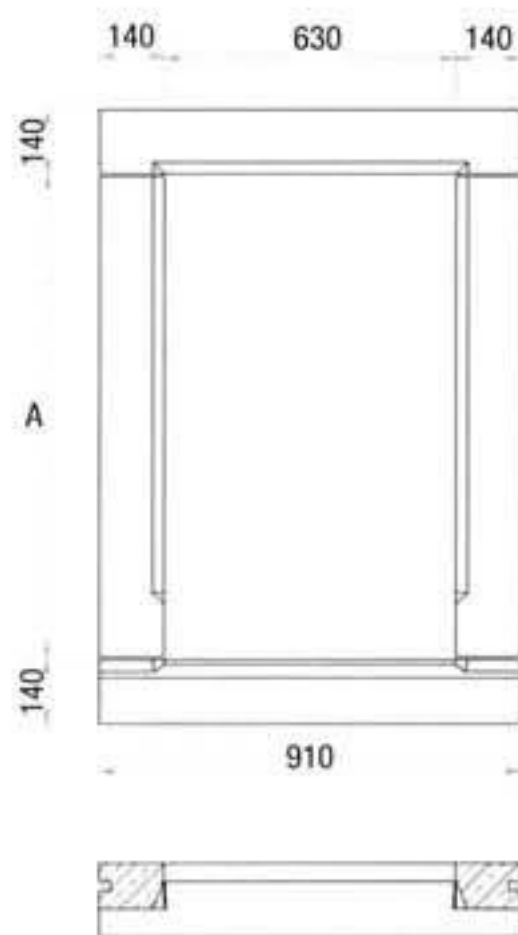

WS5

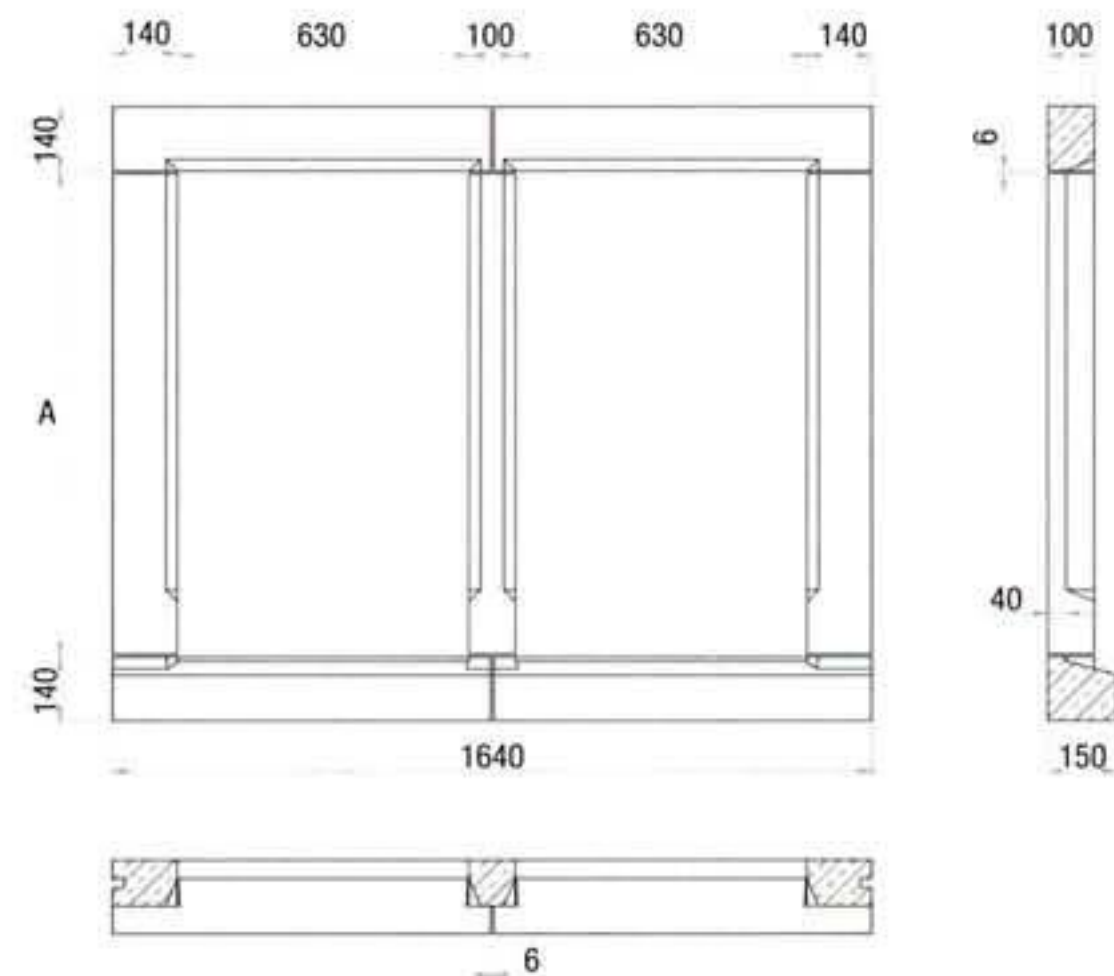

WS6

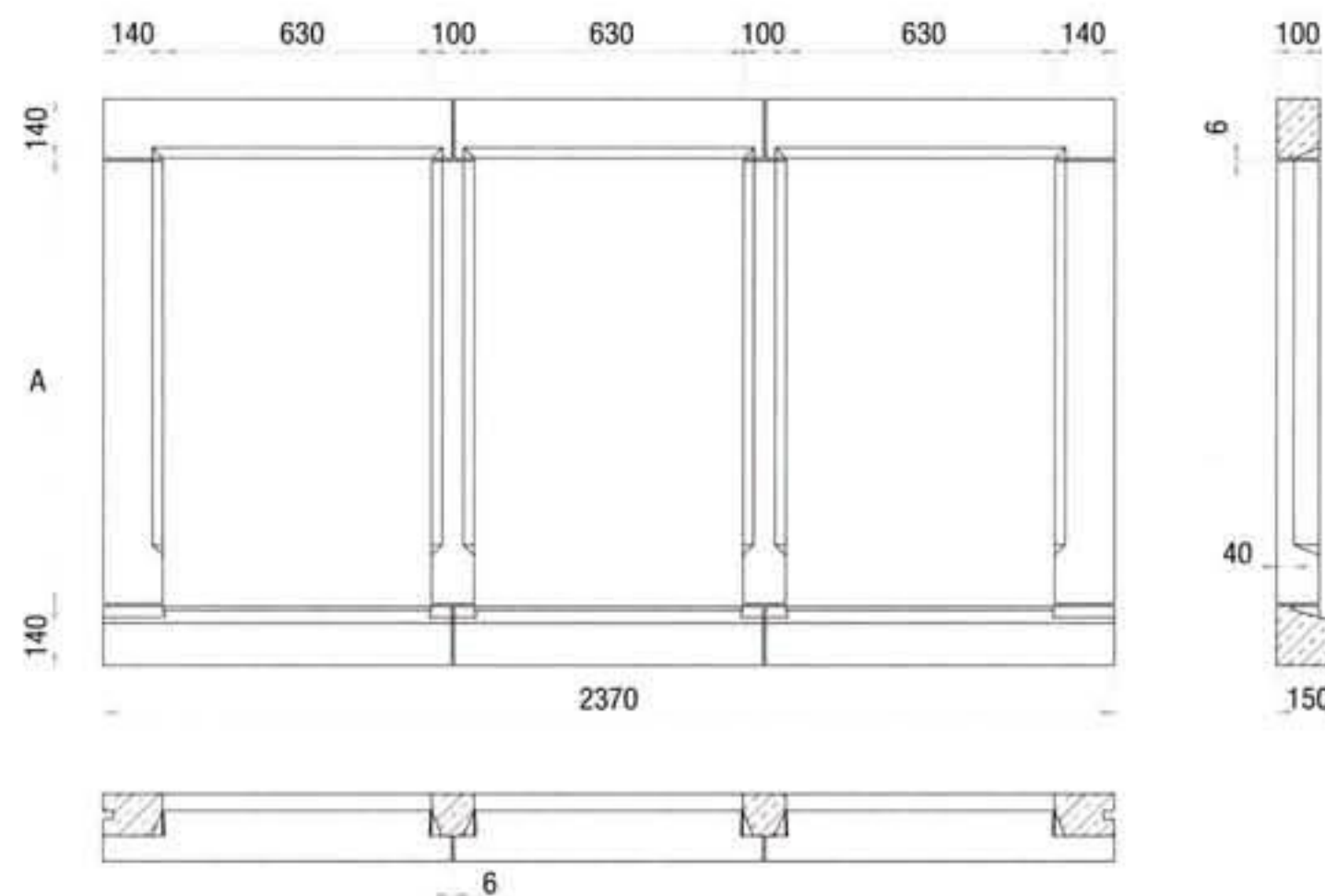

Window Surrounds



Any window surround can be manufactured to suit the height of the window. Please state height 'A' when placing the order. Jambs/mullions over 1500mm would be supplied in two pieces in line with the recommendations on slenderness ratios in BS 1217 : 1997. All window surrounds are supplied with stainless steel dovetail cramp fixings and dowels. A Technical Data Sheet showing the recommended fixing details of window surrounds is available on request. Sizes to suit standard window openings can also be supplied together with bay surrounds.

WS7

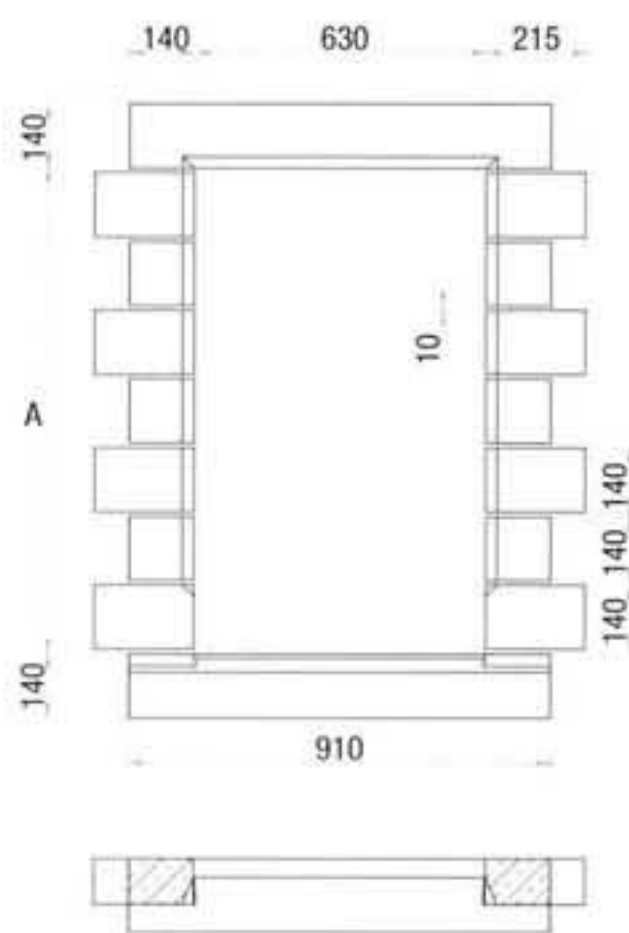

WS8

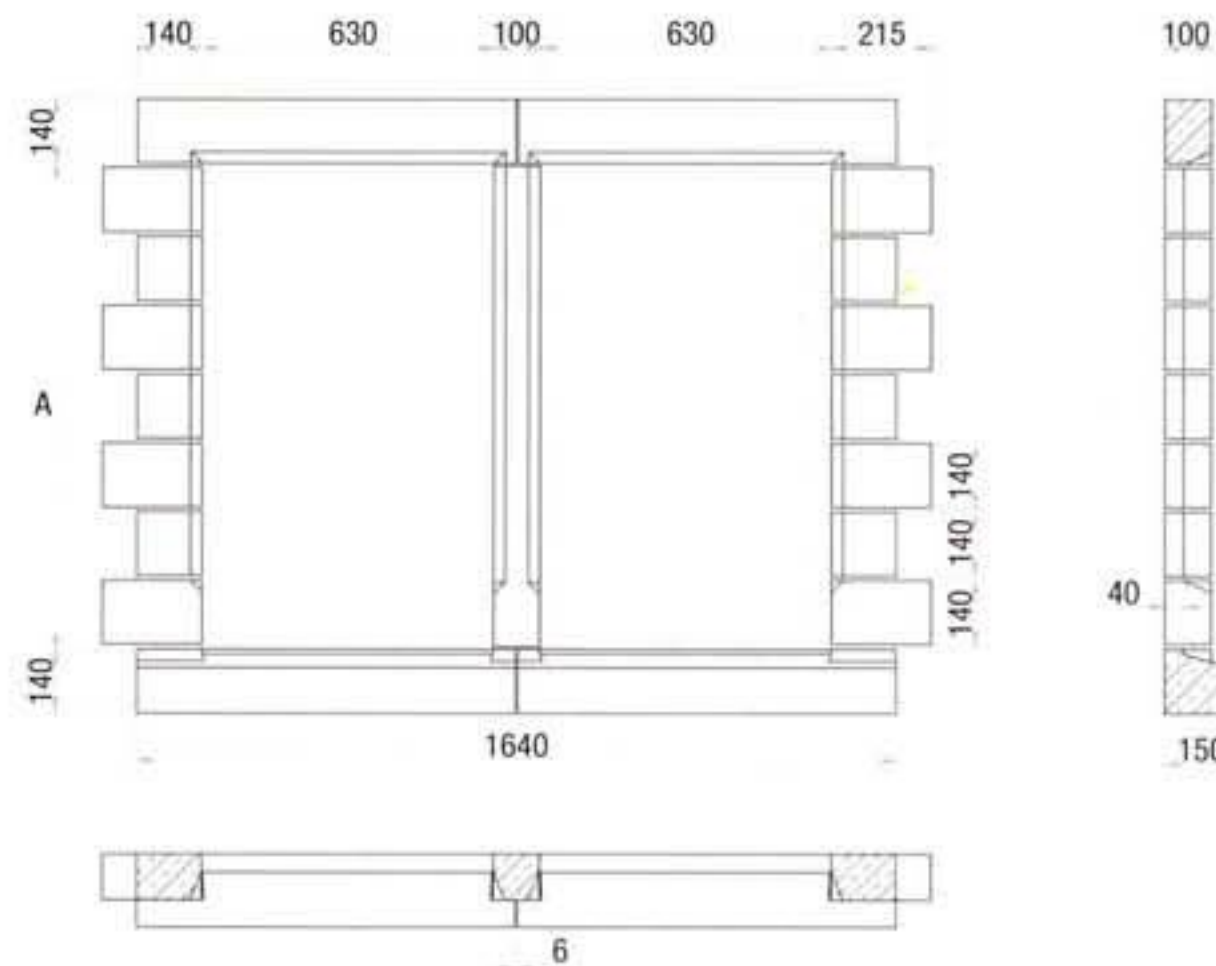

WS9

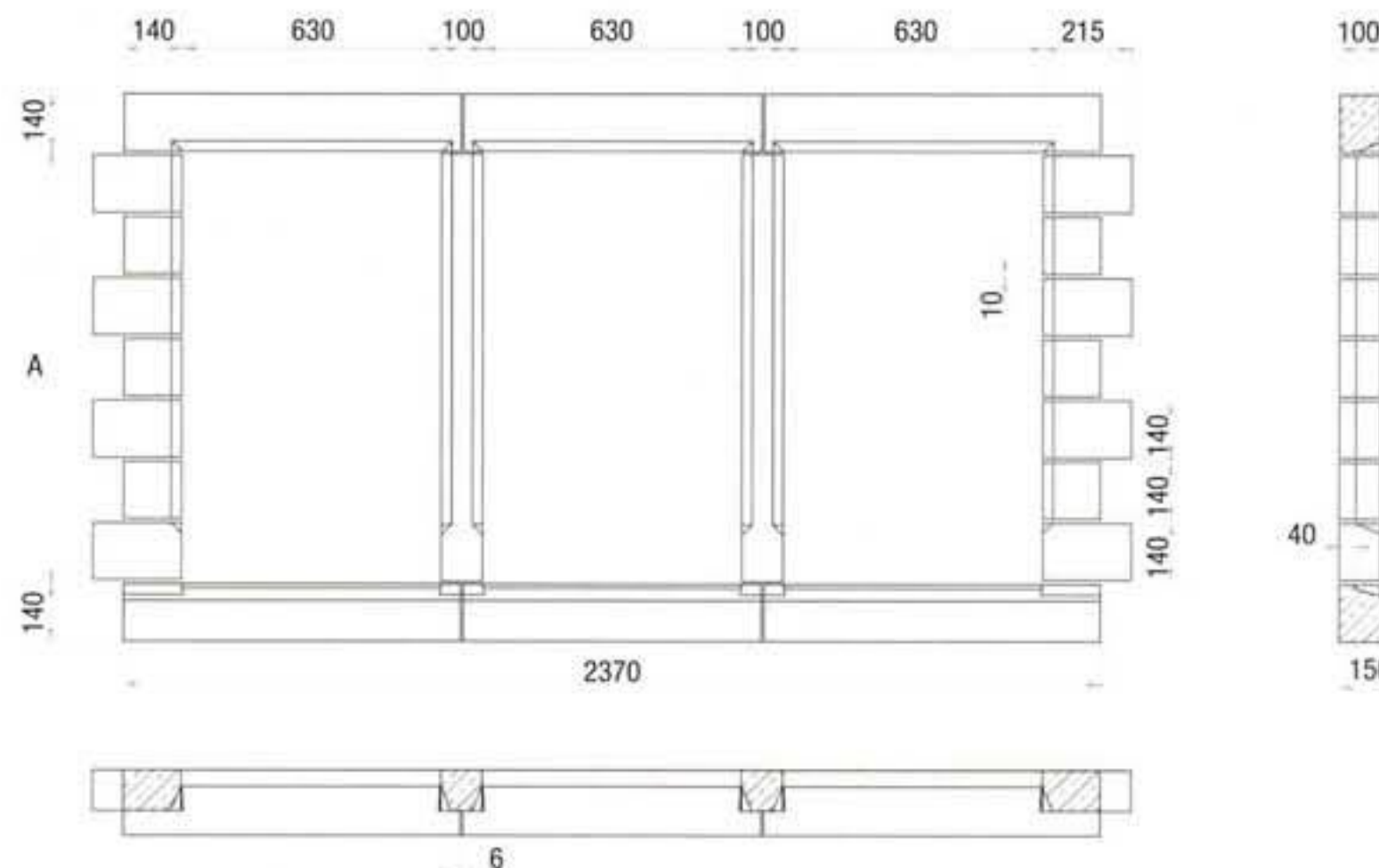

Window Surrounds



Any window surround can be manufactured to suit the height of the window. Please state height 'A' when placing the order. Jambs/mullions over 1500mm would be supplied in two pieces in line with the recommendations on slenderness ratios in BS 1217 : 1997. All window surrounds are supplied with stainless steel dovetail cramp fixings and dowels. A Technical Data Sheet showing the recommended fixing details of window surrounds is available on request. Sizes to suit standard window openings can also be supplied together with bay surrounds.

WS10

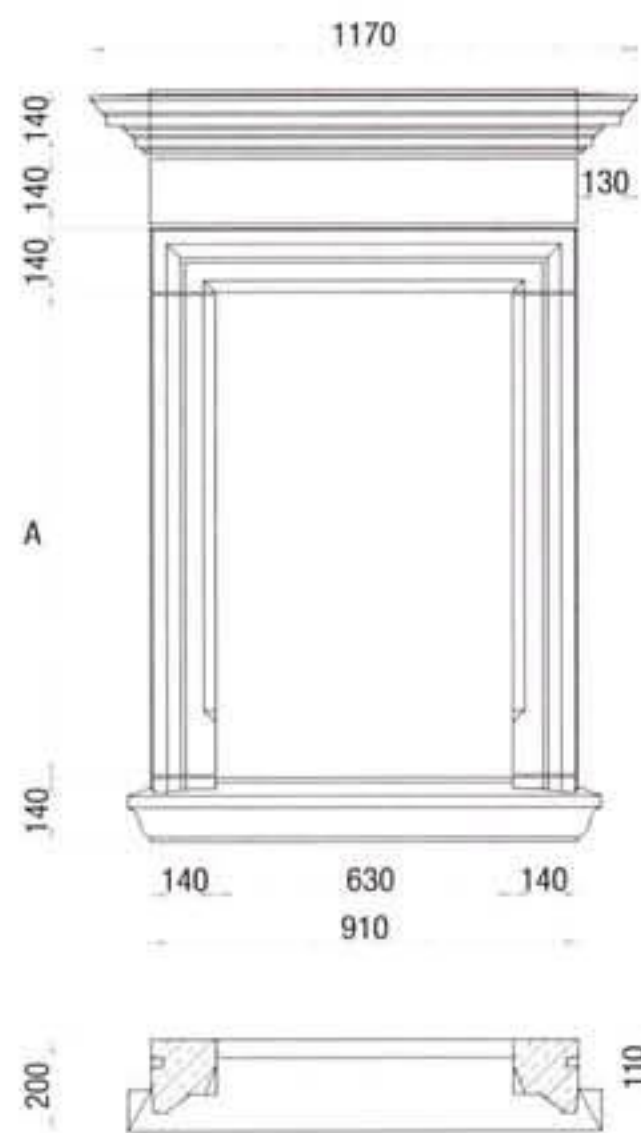

WS11

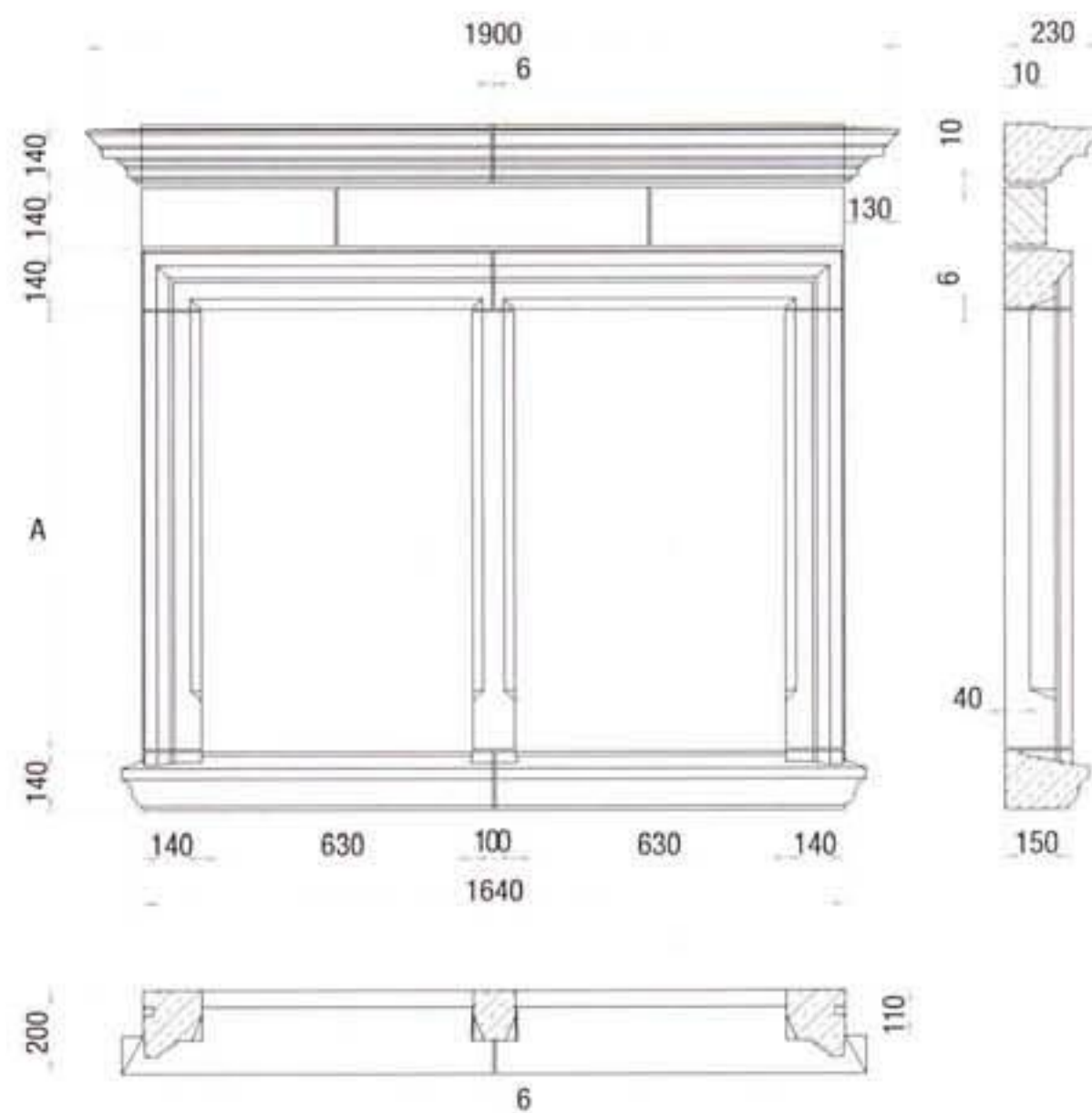

WS12

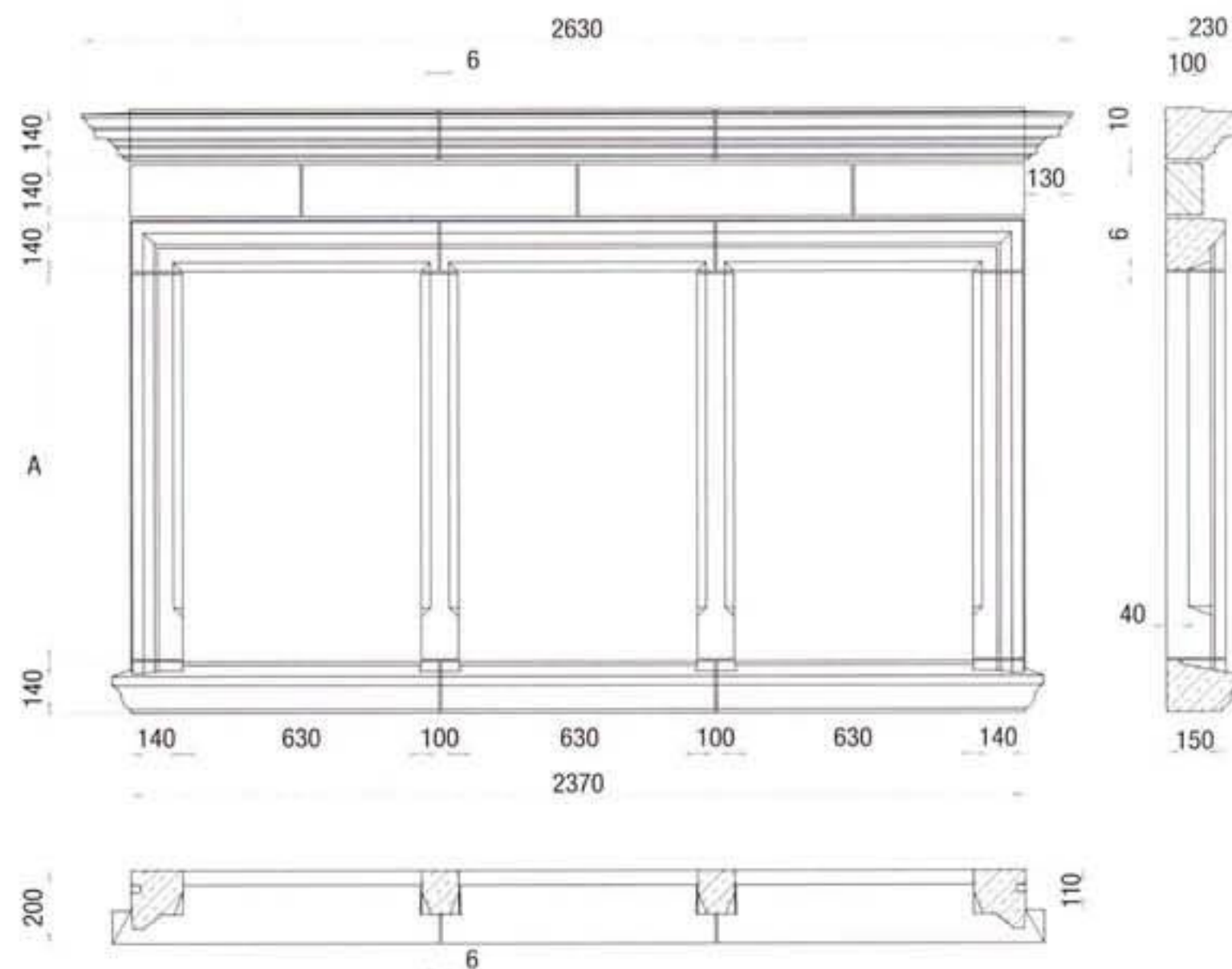

Window Surrounds

Any window surround can be manufactured to suit the height of the window. Please state height 'A' when placing the order. Jamb/mullions over 1500mm would be supplied in two pieces in line with the recommendations on slenderness ratios in BS 1217 : 1997. All window surrounds are supplied with stainless steel dovetail cramp fixings and dowels. A Technical Data Sheet showing the recommended fixing details of window surrounds is available on request. Sizes to suit standard window openings can also be supplied together with bay surrounds.



WS13

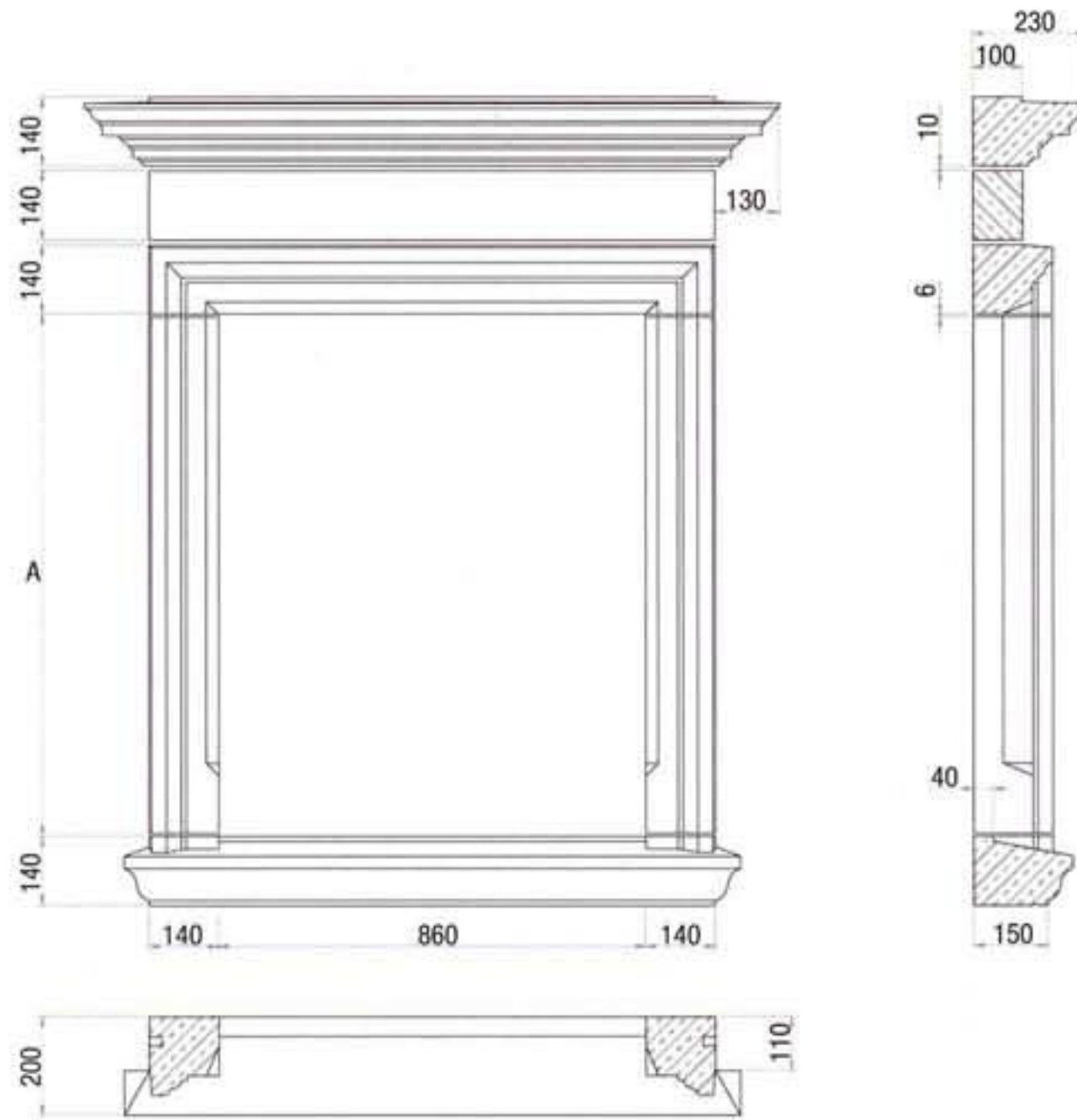

WS14

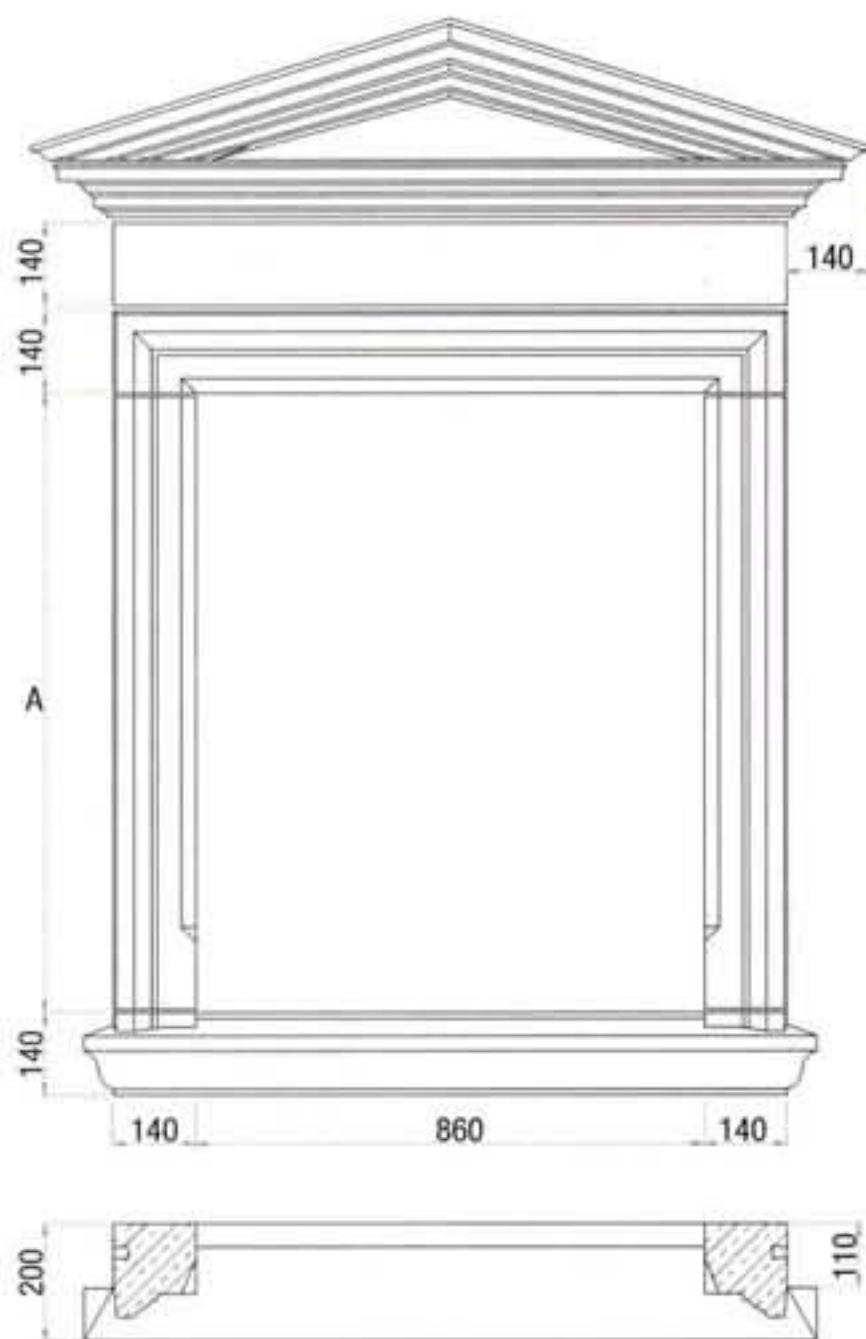

WS15

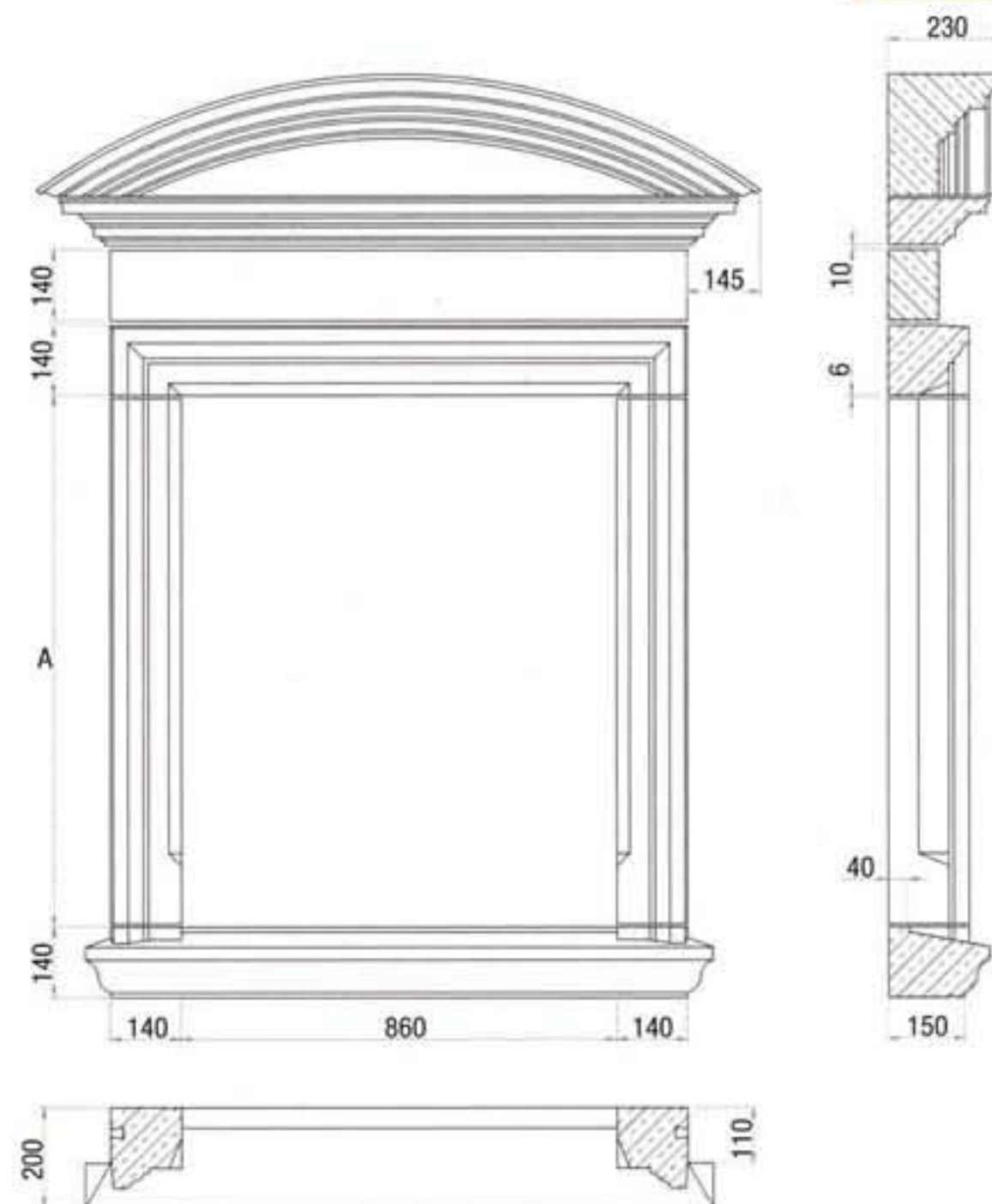



Window Surrounds

Any window surround can be manufactured to suit the height of the window. Please state height 'A' when placing the order. Jambs/mullions over 1500mm would be supplied in two pieces in line with the recommendations on slenderness ratios in BS 1217 : 1997. All window surrounds are supplied with stainless steel dovetail cramp fixings and dowels. A Technical Data Sheet showing the recommended fixing details of window surrounds is available on request. Sizes to suit standard window openings can also be supplied together with bay surrounds.

WS16

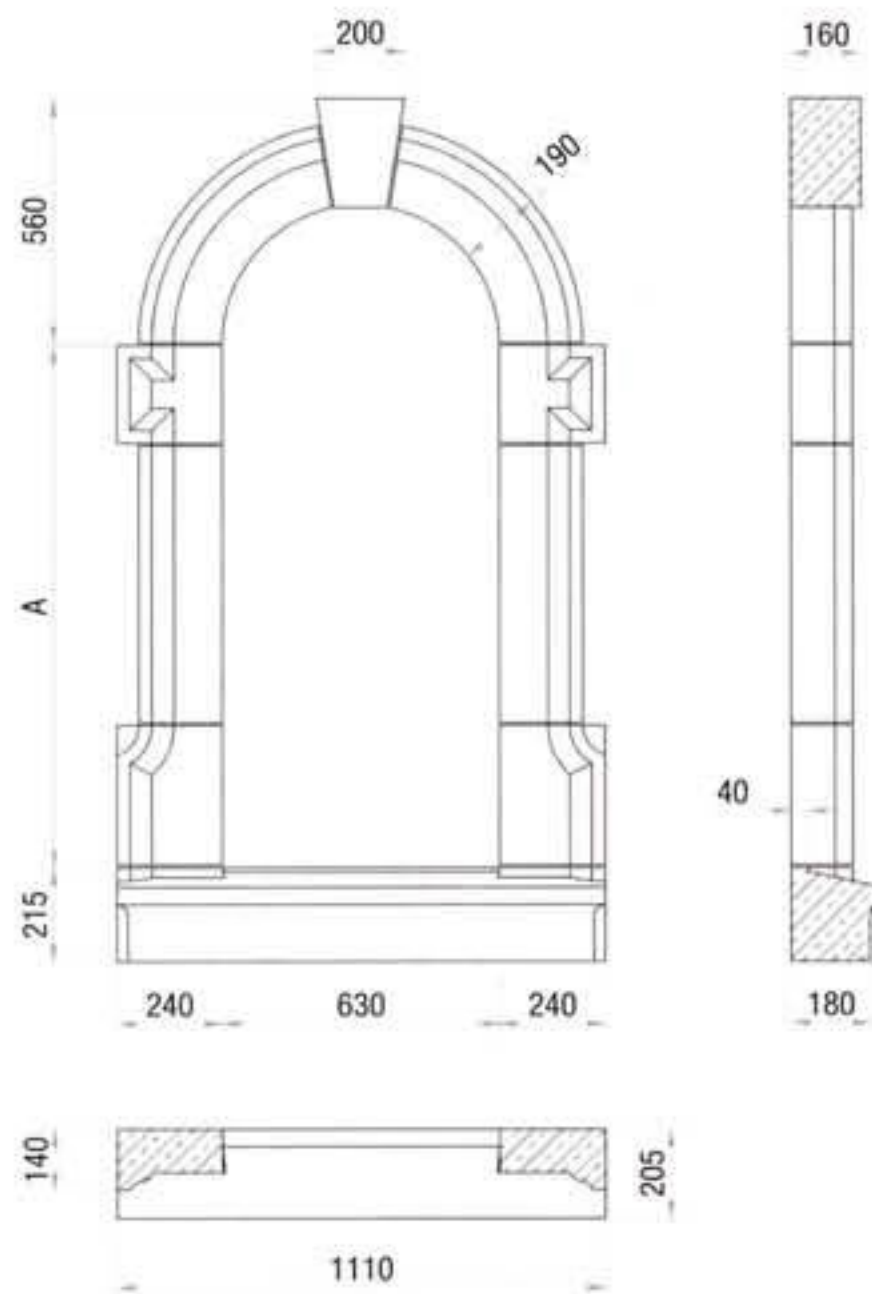

WS17

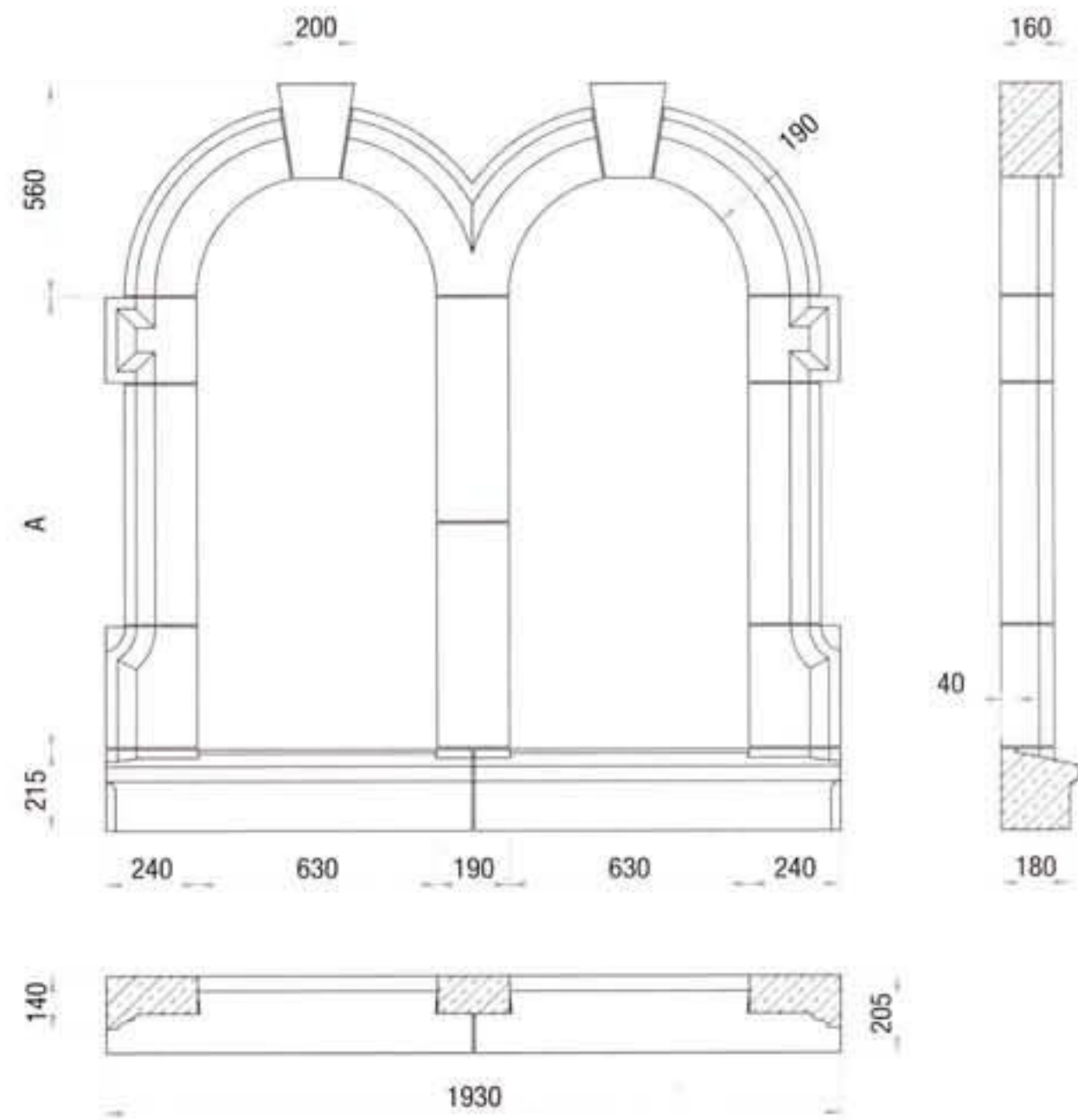

WS18

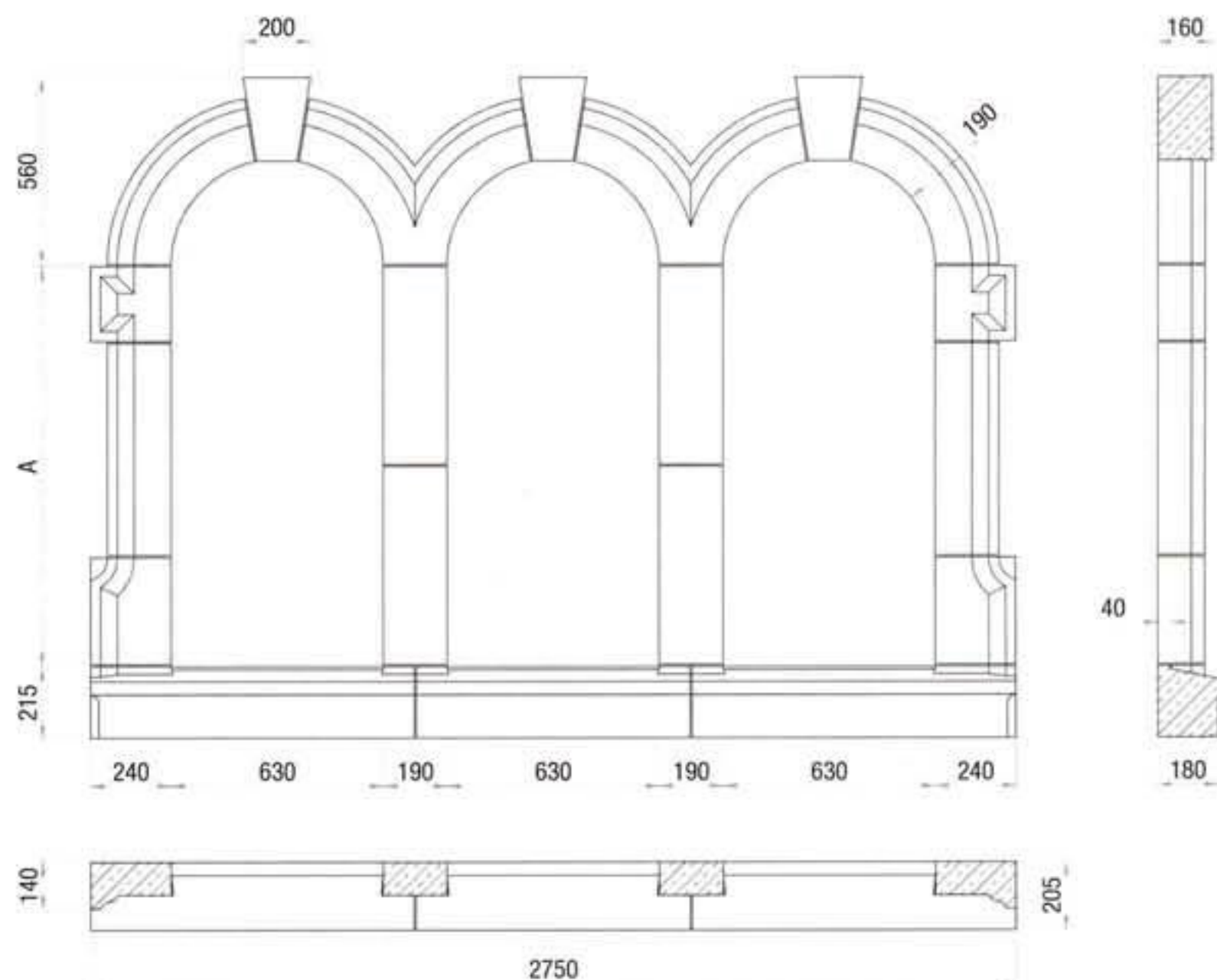

Octagonal Window Surround



OS1

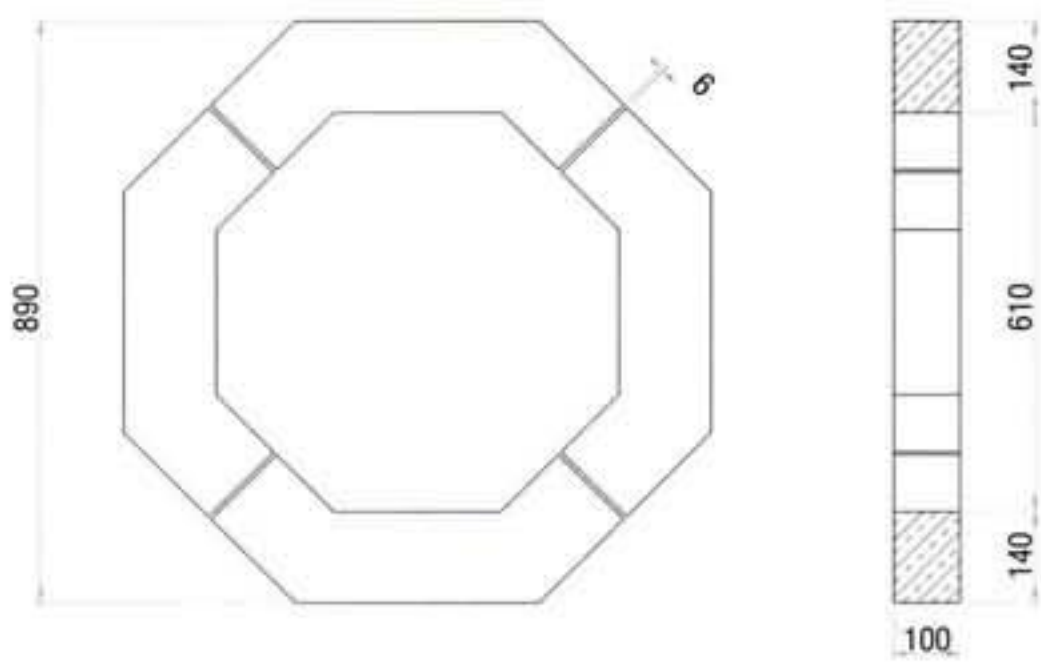

Total Weight: 74Kg

OS4

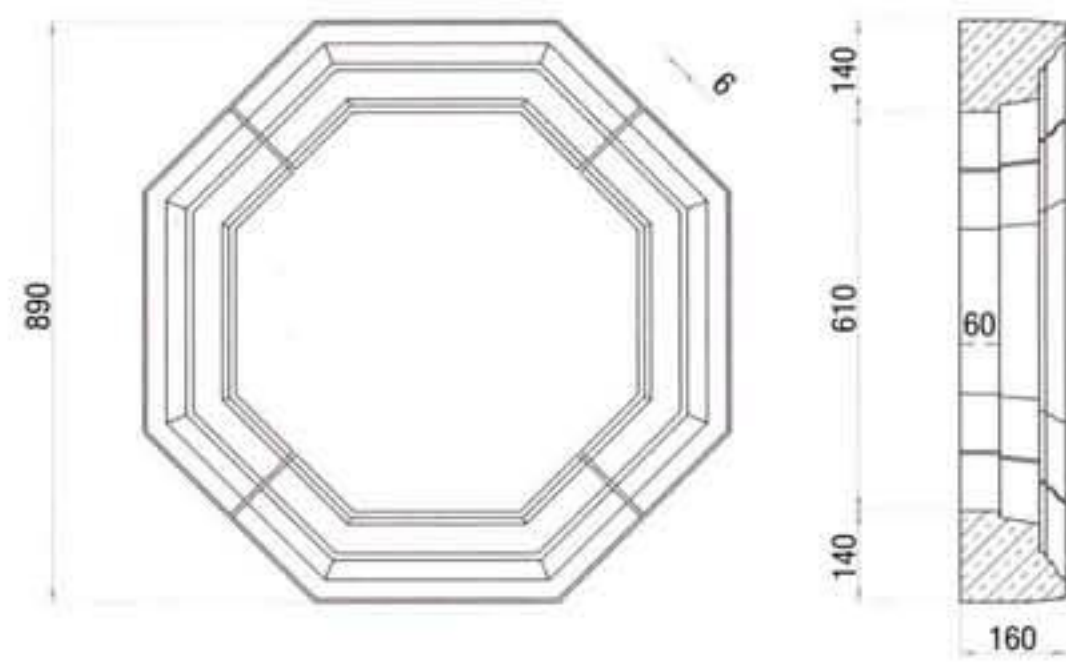

Total Weight: 96Kg

OS2

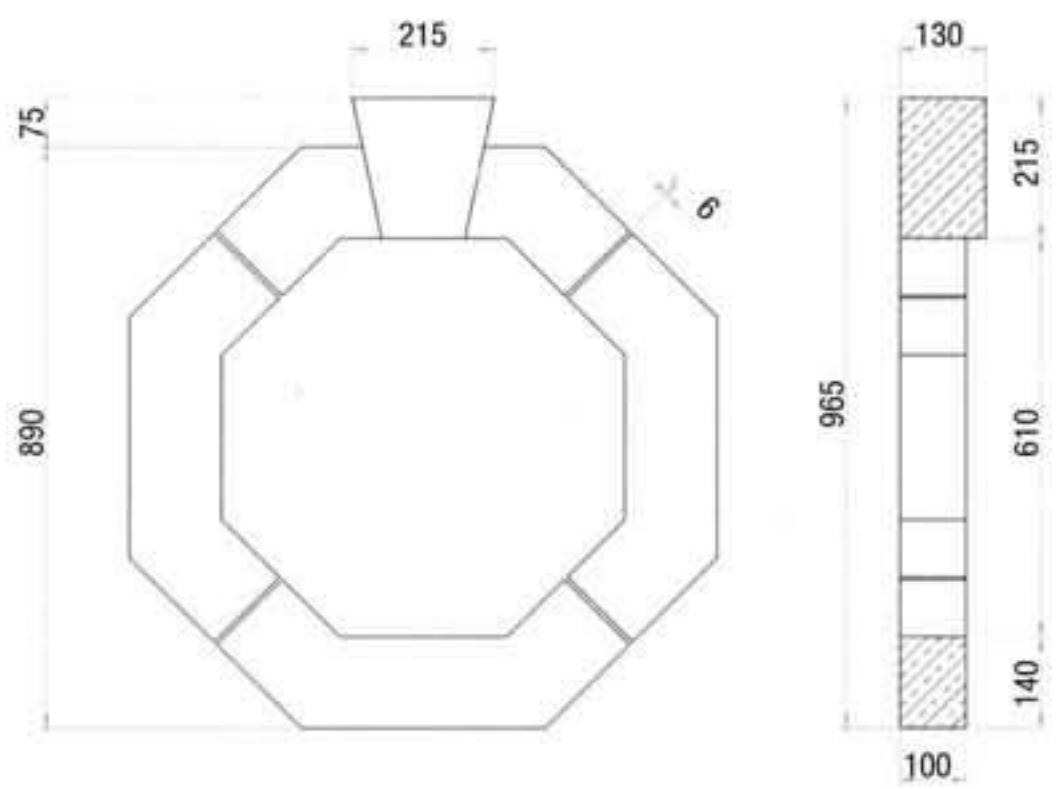

Total Weight: 80Kg

OS5

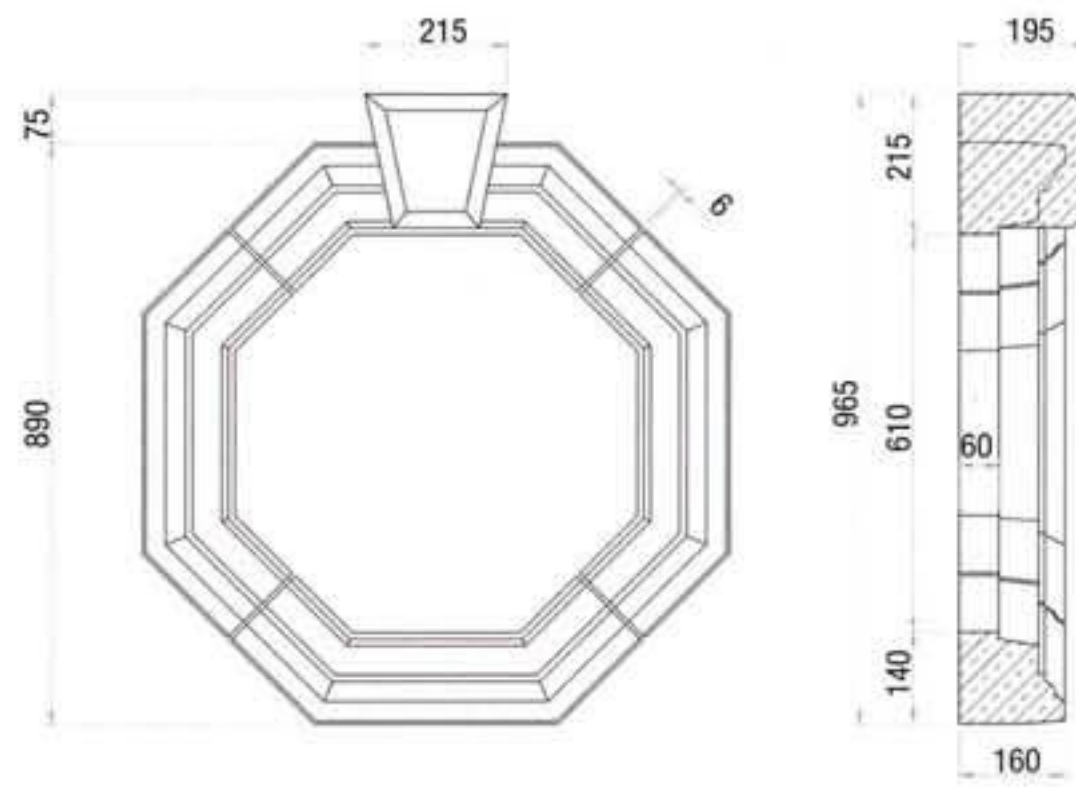

Total Weight: 105Kg

OS3

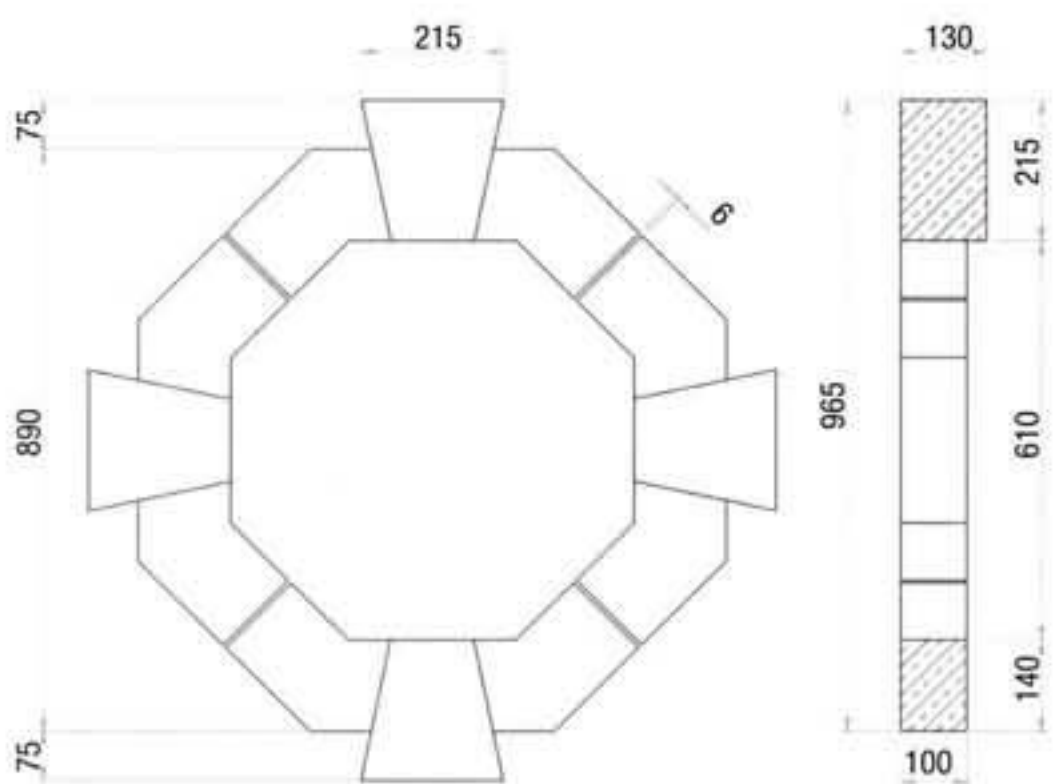

Total Weight: 96Kg

OS6

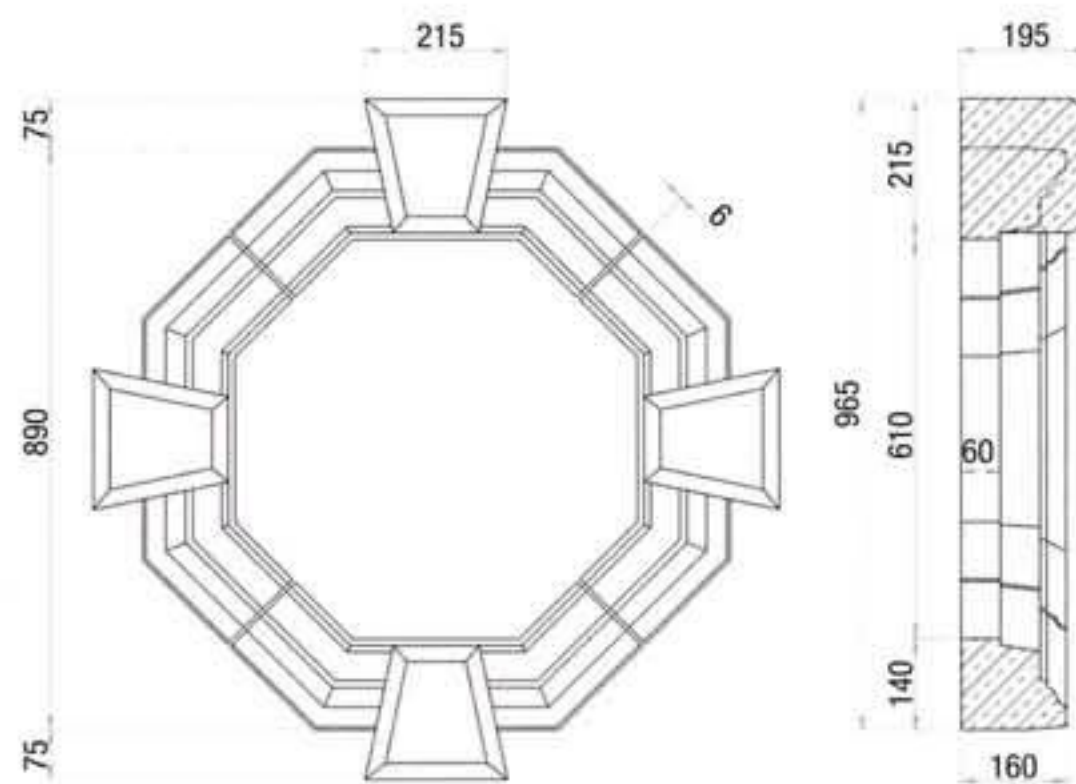

Total Weight: 130Kg



Circular Window Surrounds

All circular windows surrounds on this page have been based on a standard 600mm diameter window.

CW4

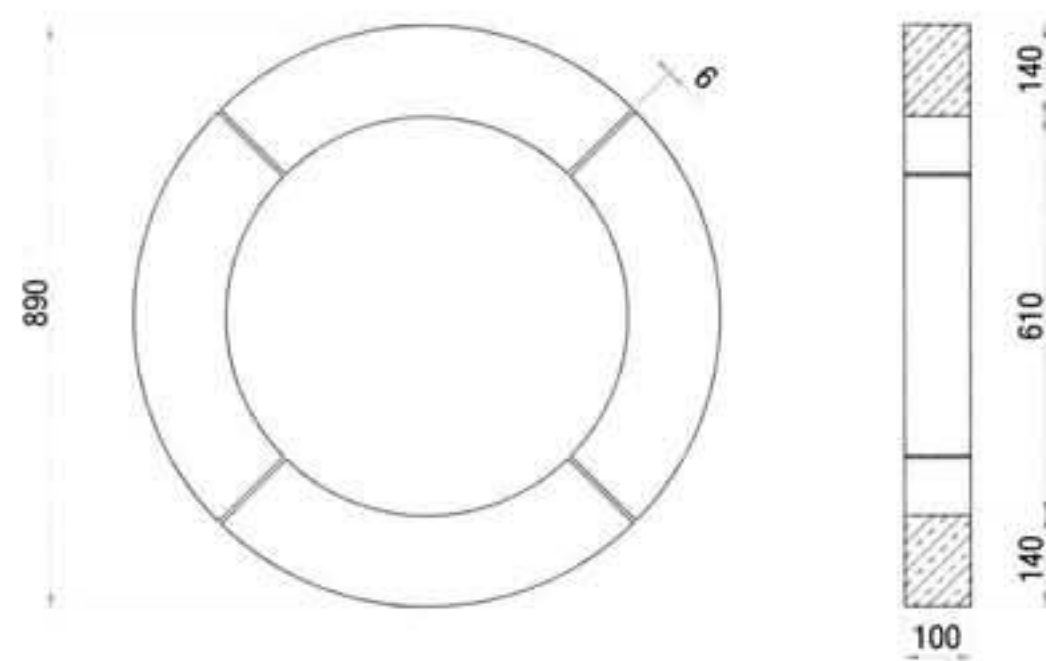

Total Weight: **70Kg**

CW7

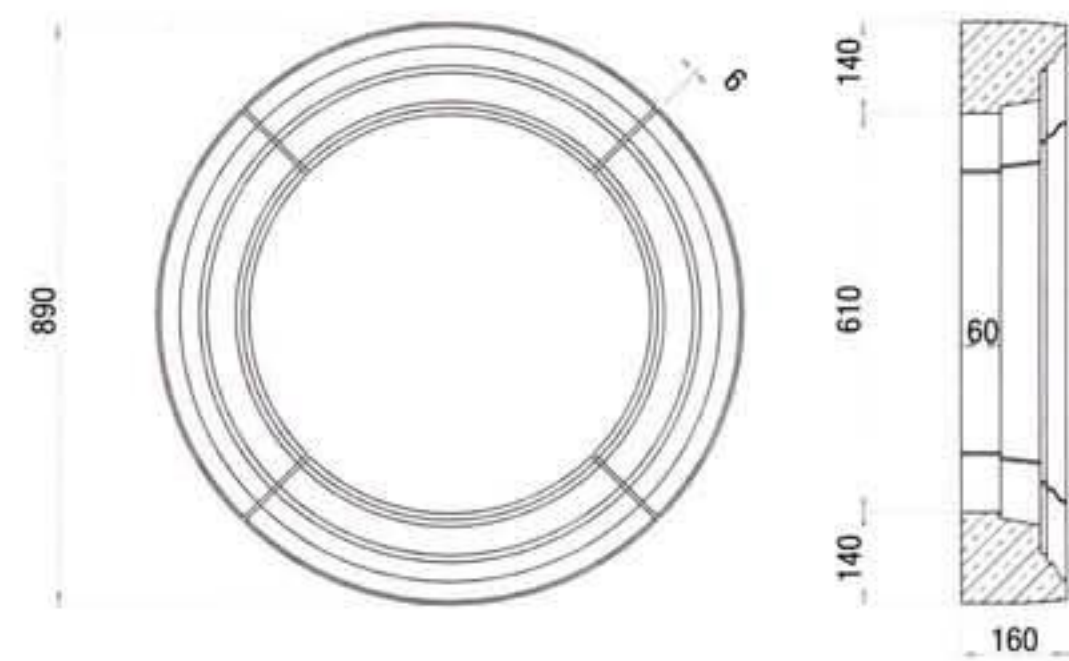

Total Weight: **91Kg**

CW5

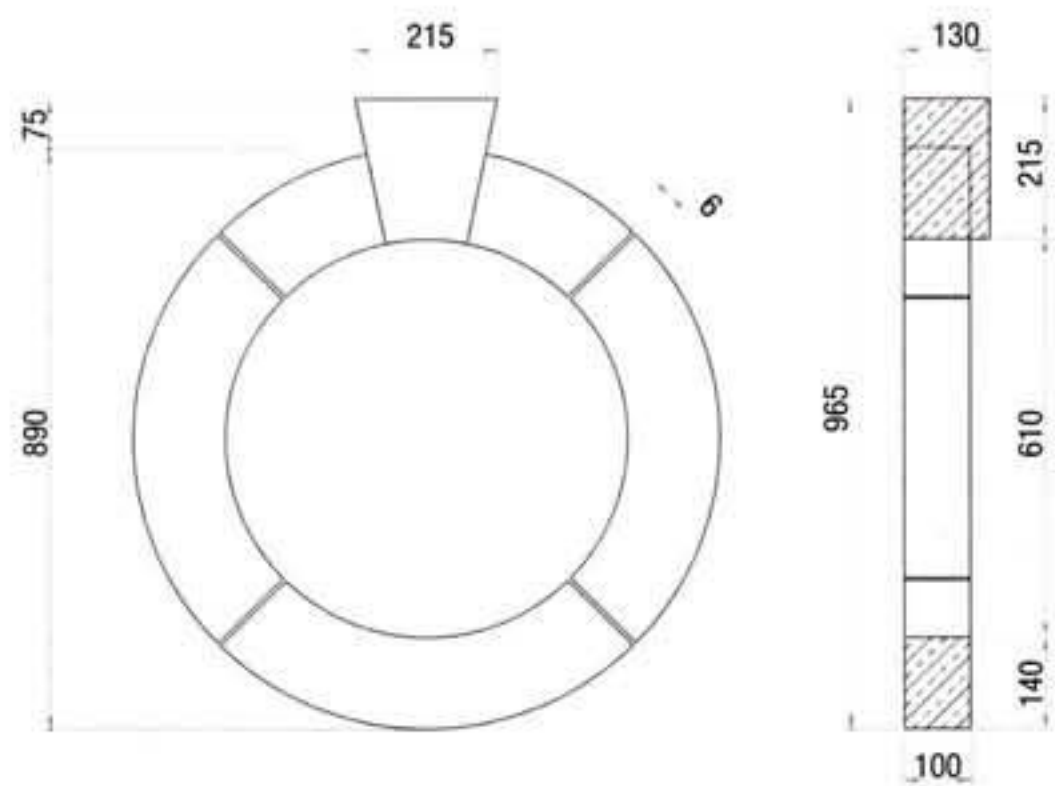

Total Weight: **76Kg**

CW8

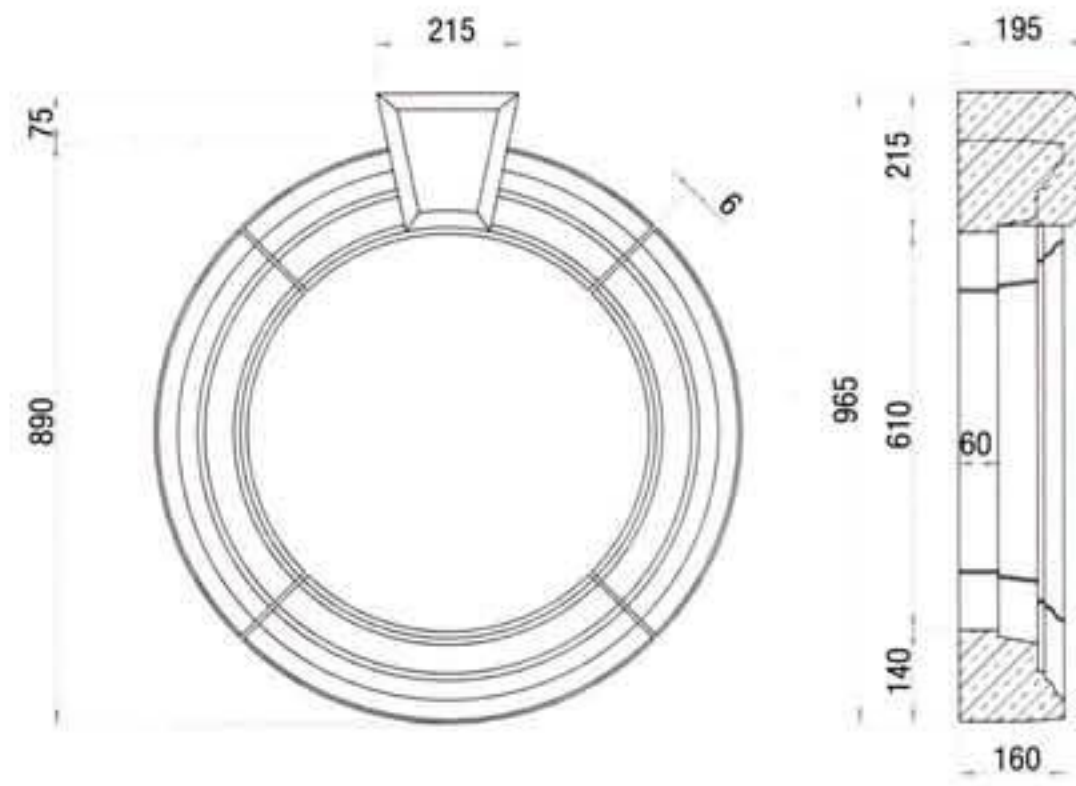

Total Weight: **100Kg**

CW6

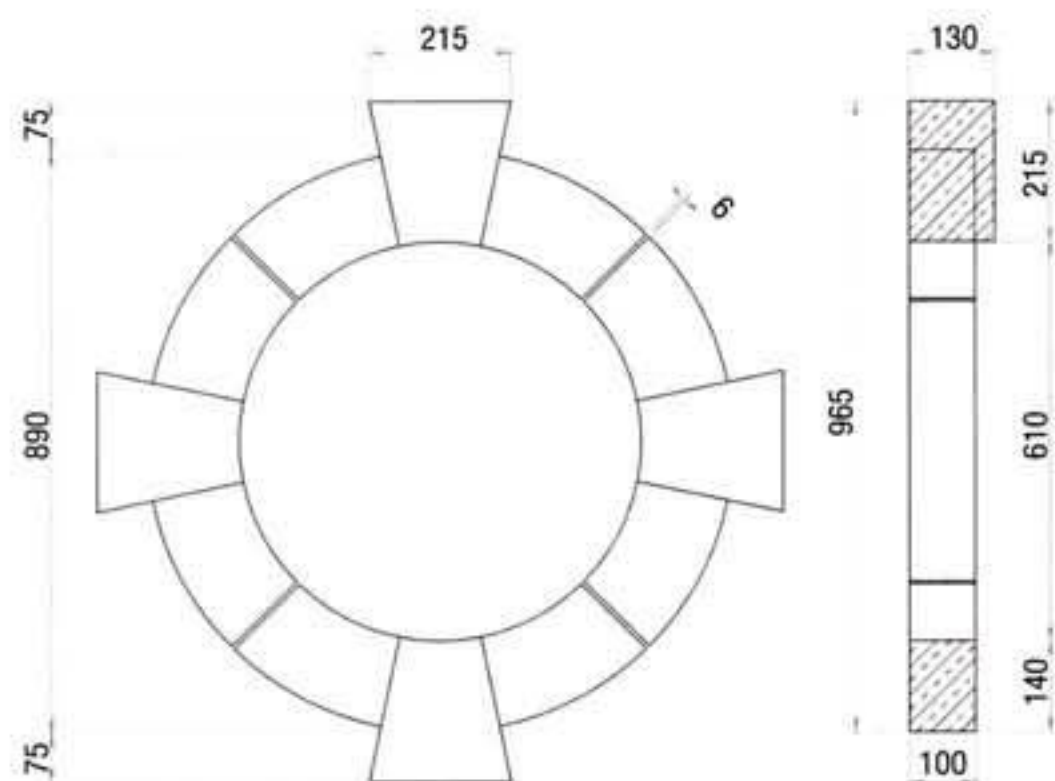

Total Weight: **92Kg**

CW9

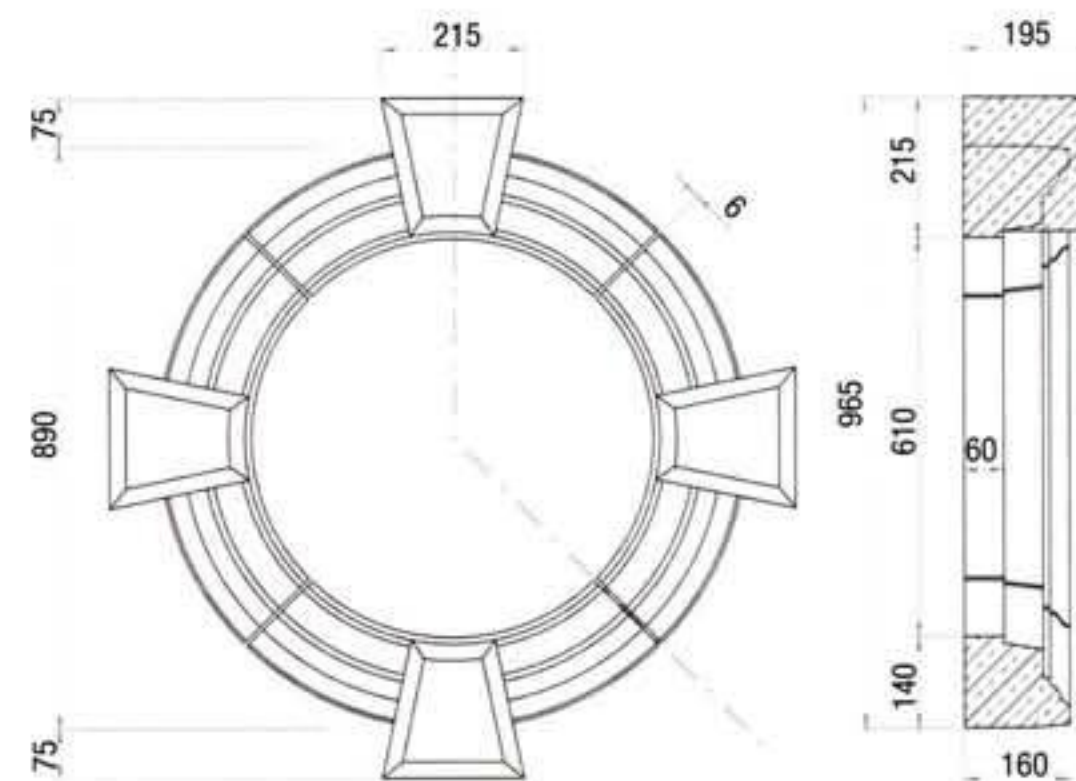

Total Weight: **125Kg**

Circular Window Surrounds



CW2

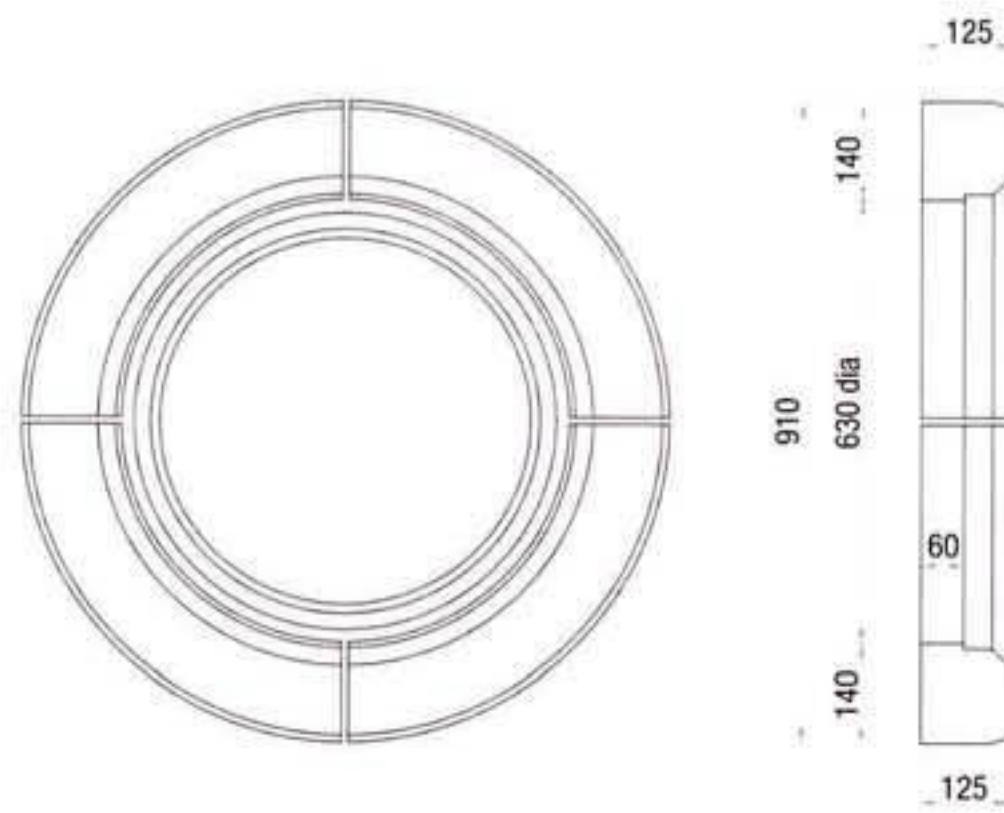

Total Weight: 82Kg

CW3

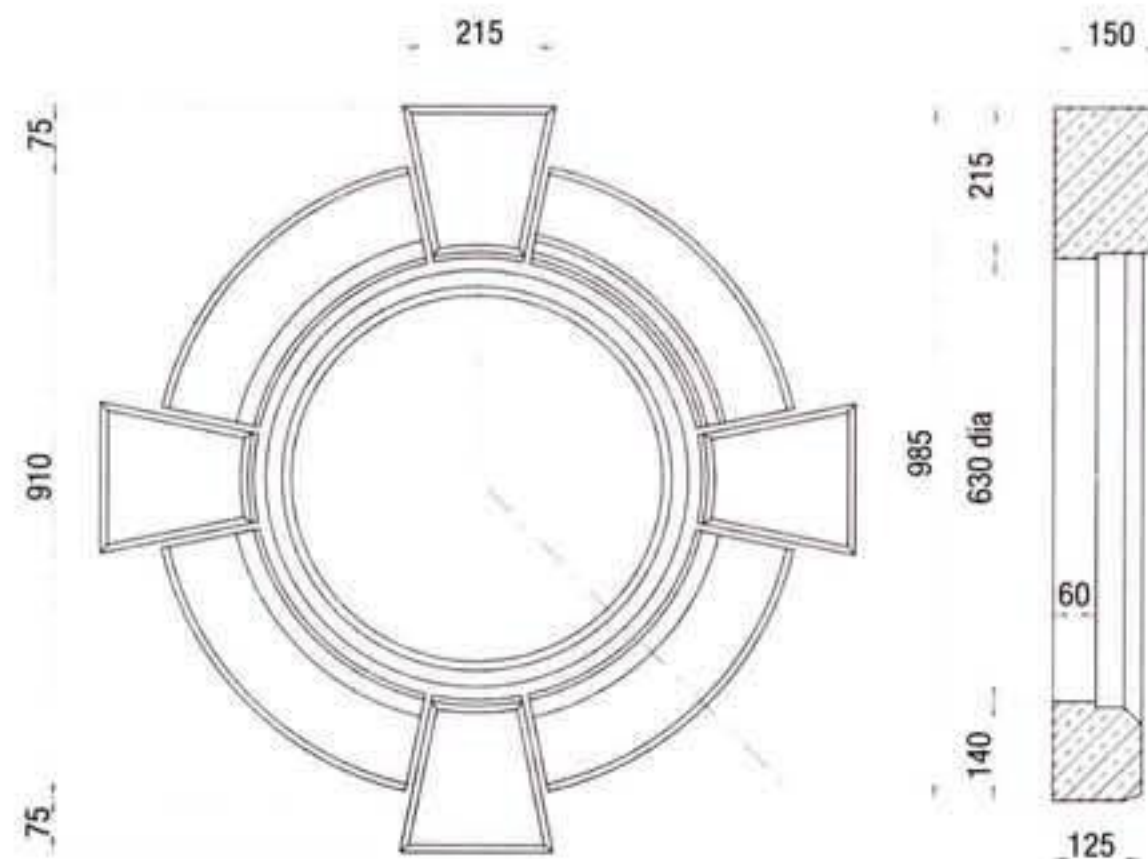

Total Weight: 124Kg



Circular Window Surrounds

All circular windows surrounds on this page have been based on a standard 900mm diameter window.

Clip over keystones have been used please see page 31 for details.

CW10

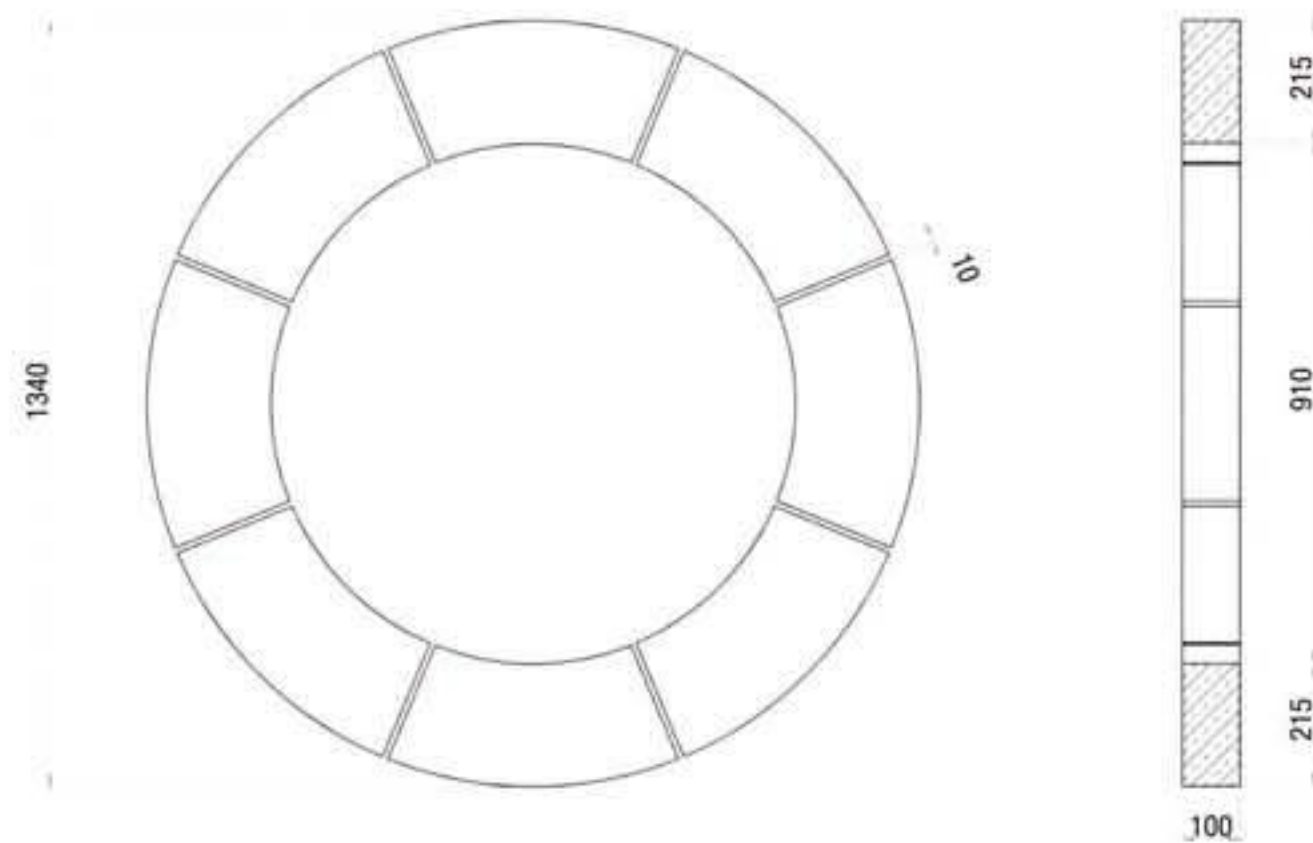

Total Weight: 160Kg

CW11

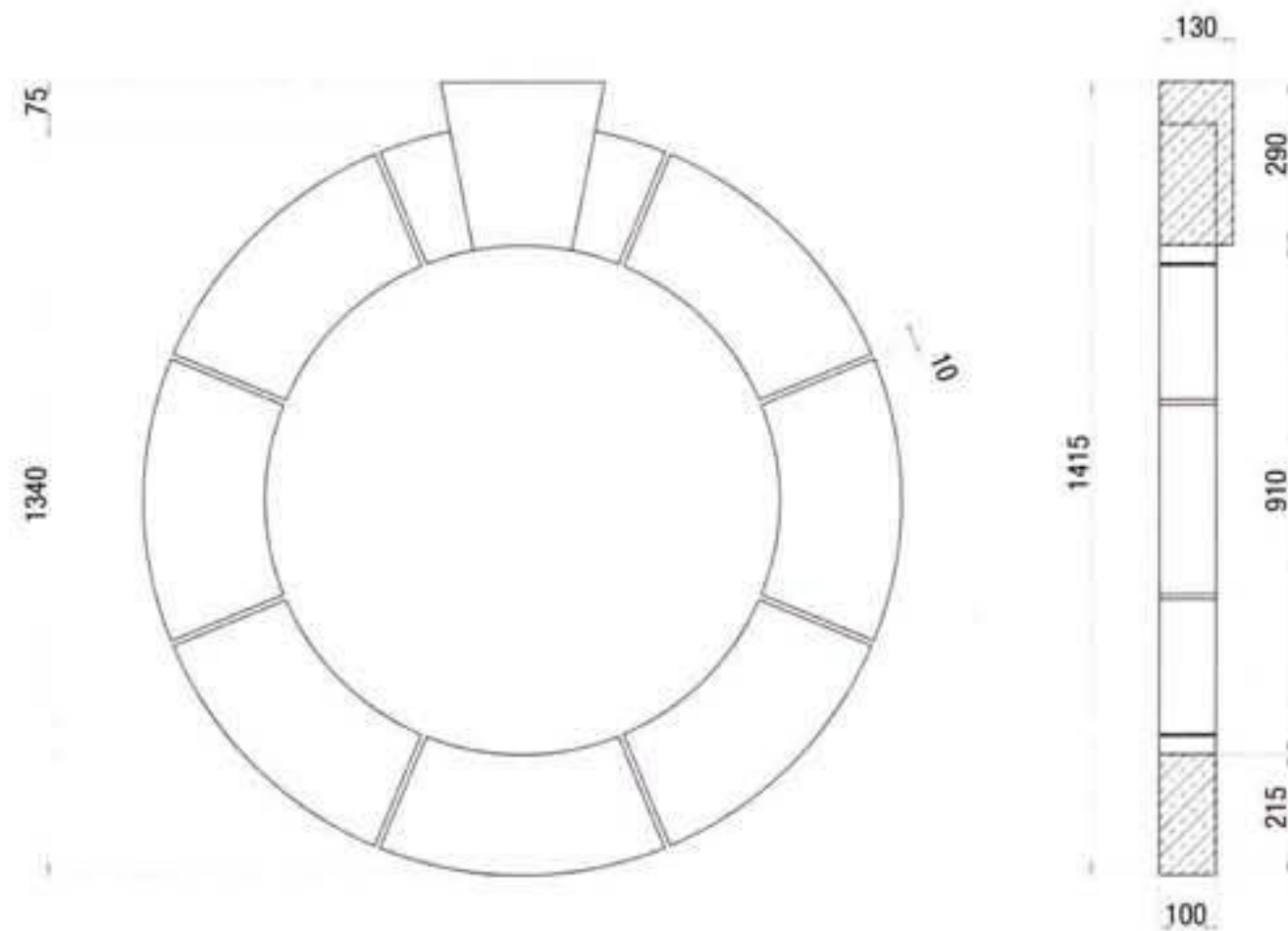

Total Weight: 169Kg

CW12

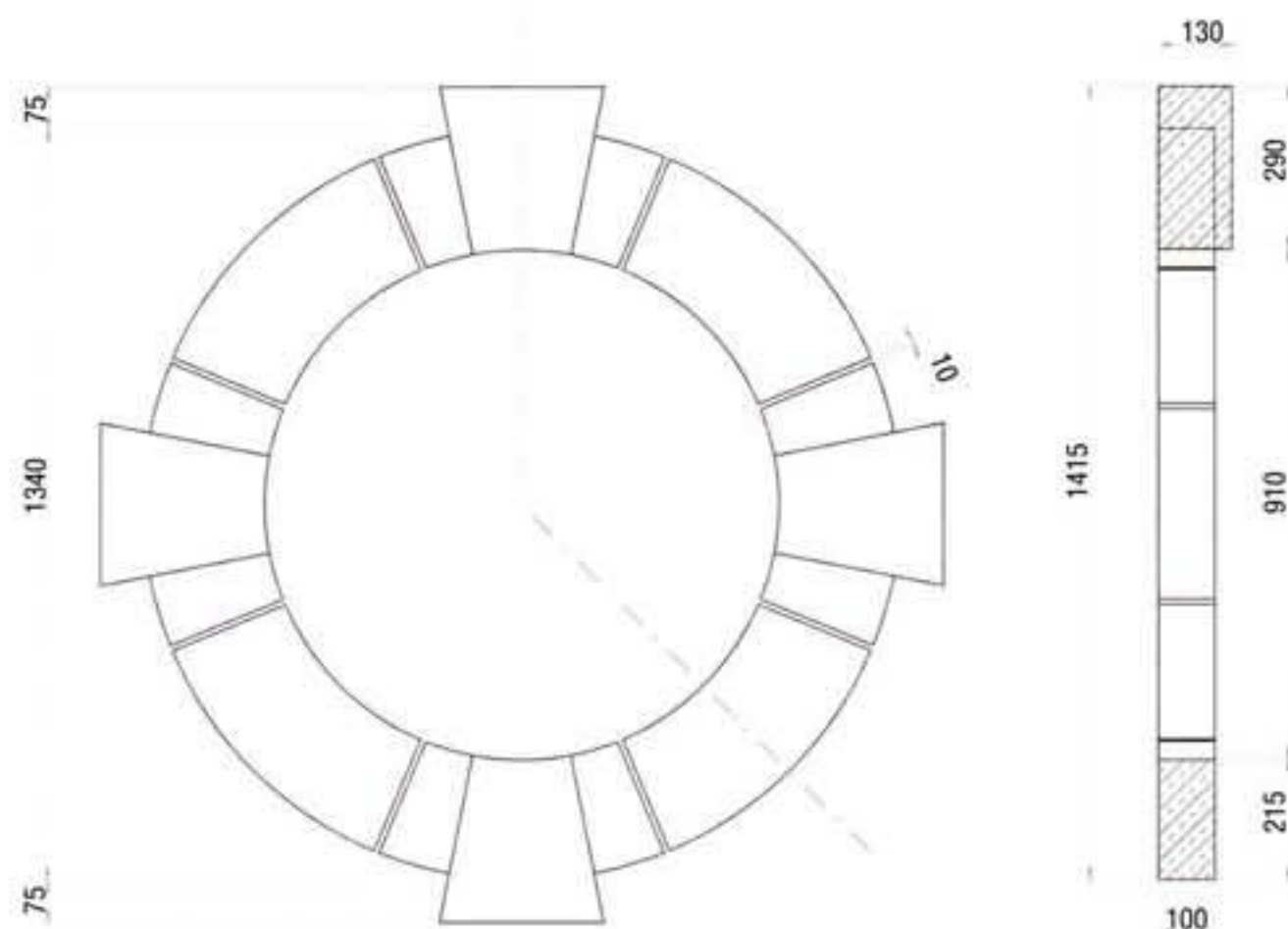

Total Weight: 196Kg

Circular Window Surrounds

All circular windows surrounds on this page have been based on a standard 900mm diameter window.

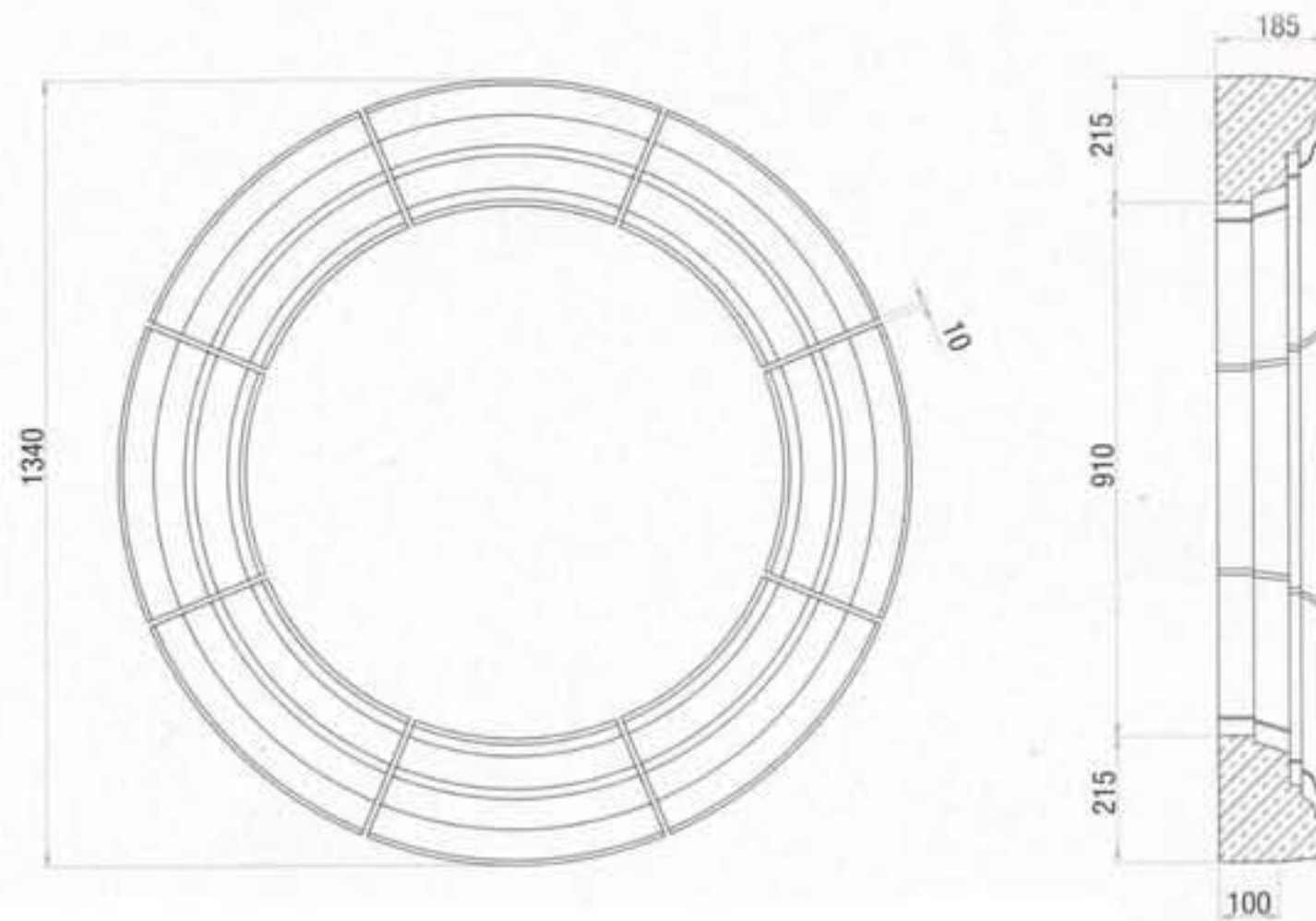

CW13

Total Weight: 235Kg

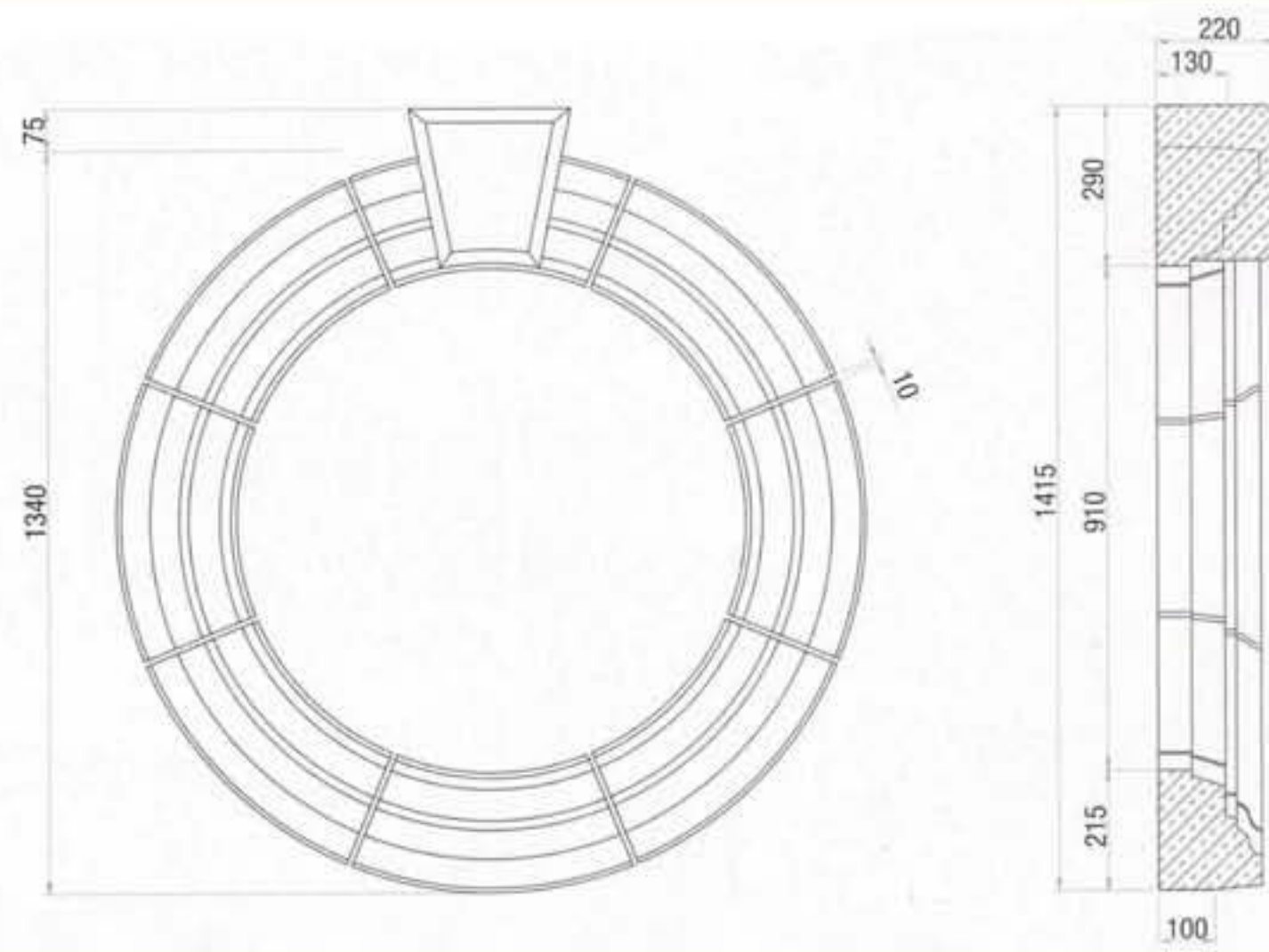

CW14

Total Weight: 250Kg

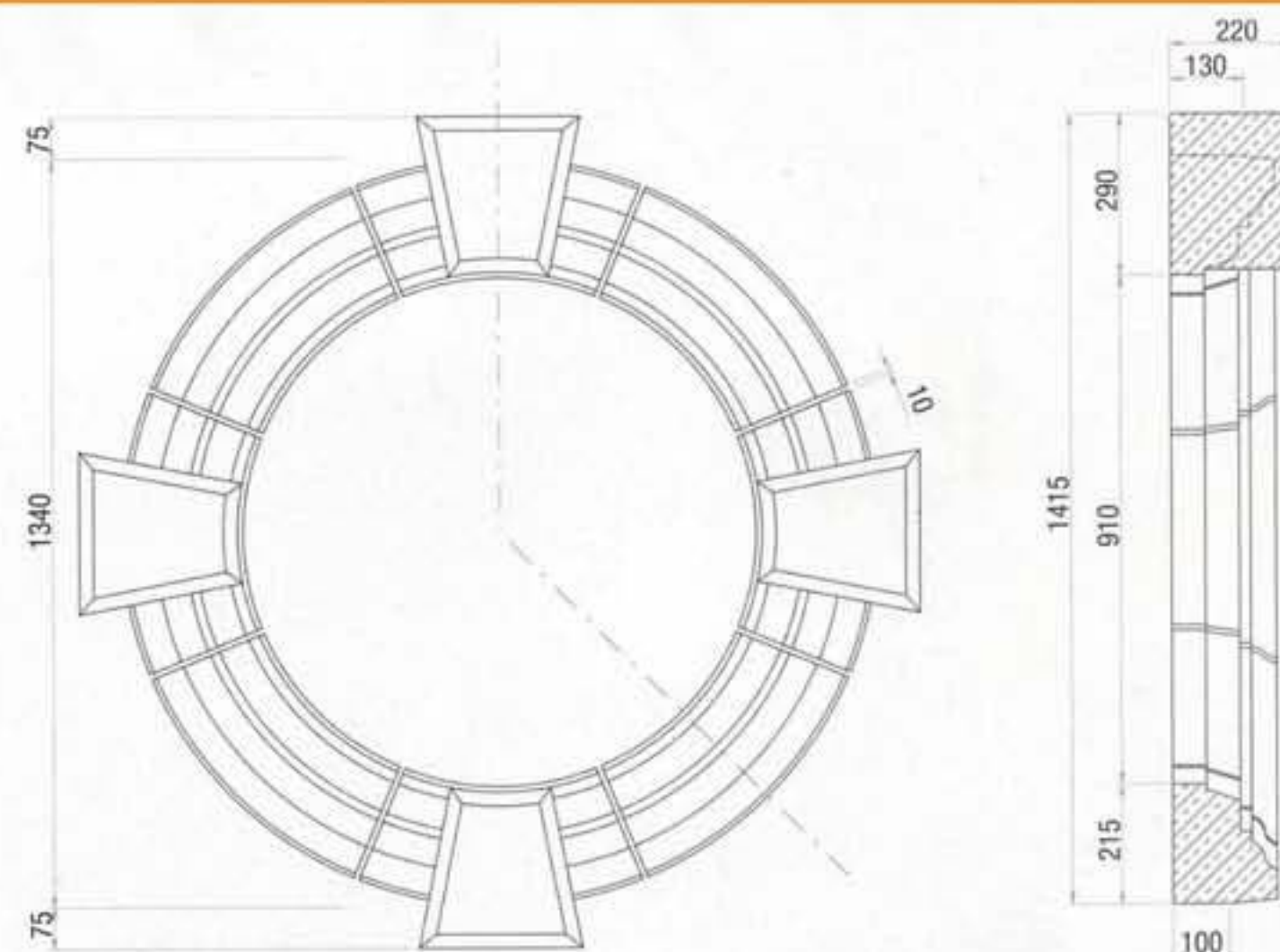

CW15

Total Weight: 300Kg

Heads



Heads can be manufactured with a pistol recess in the soffit to accommodate support angle/lintel if required (not H6).

HK1, HK2 and HK3 can be splayed or plain. Please specify when ordering.

A Technical Data Sheet showing the recommended installation details for heads is available on request.

H

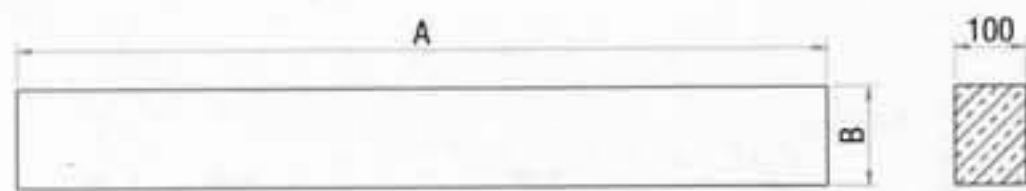

Code	A max*	B	Weight (kg/m)
H1*	1500	140	36
H3*		215	46
H4	1200	290	61
H5		365	78

* denotes products in The Homestyle Range

HF

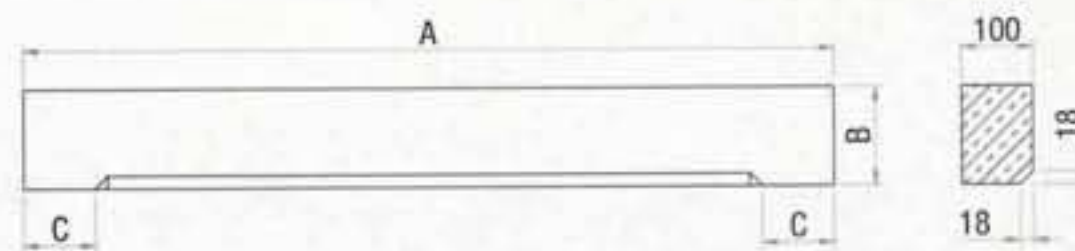

Dimension C is the bearing

Code	A max*	B	Weight (kg/m)
H1F	1500	140	30
H3F		215	46
H4F	1200	290	61
H5F		365	78

H6

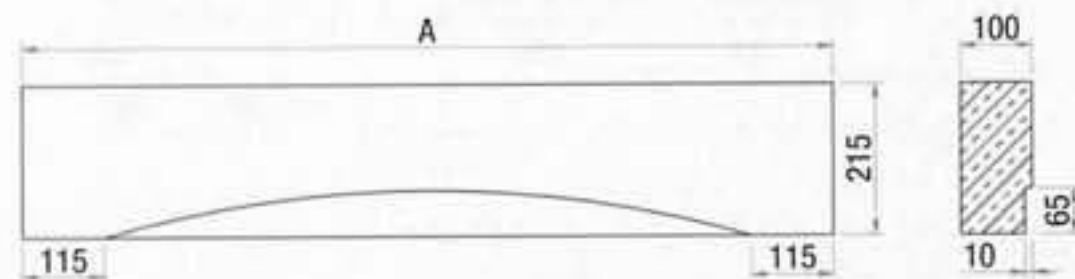

Code	A	Pieces	Weight (kg)
H6-830	830	1	37
H6-1115	1115	1	49
H6-1400	1400	1	62
H6-1970	1970	2	87

HSH

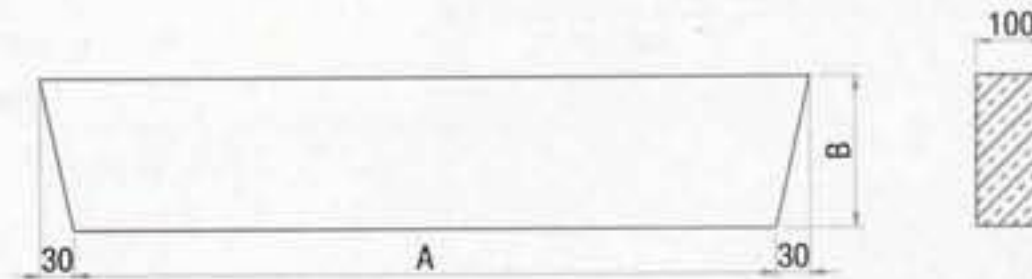

Code	A max*	B	Weight (kg/m)
HSH*	1500	215	46
HSH2	1200	290	61

* denotes products in The Homestyle Range

HK

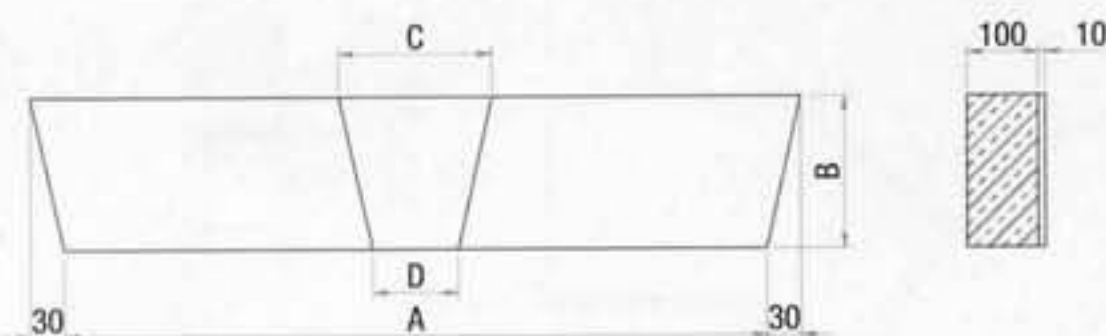

Code	A max*	B	C	D	Weight (kg/m)
HK1	1500	215	215	120	46
HK2	1200	290	300	150	61

HK

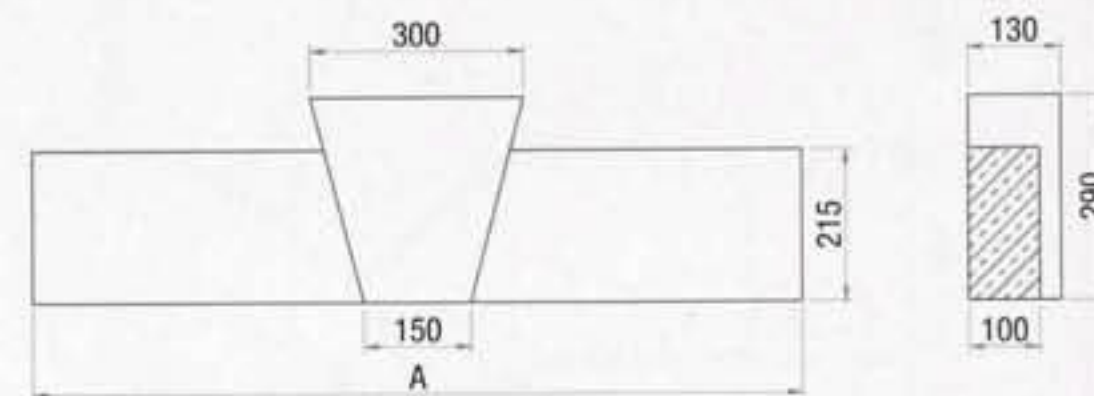

Code	A max*	Weight (kg/m)
HK3	1500	46

Archstones

Voisoir arches require either a support lintel under the soffit or a lintel above to carry the load. Temporary centring (support) will be required to construct the arch.



VA1

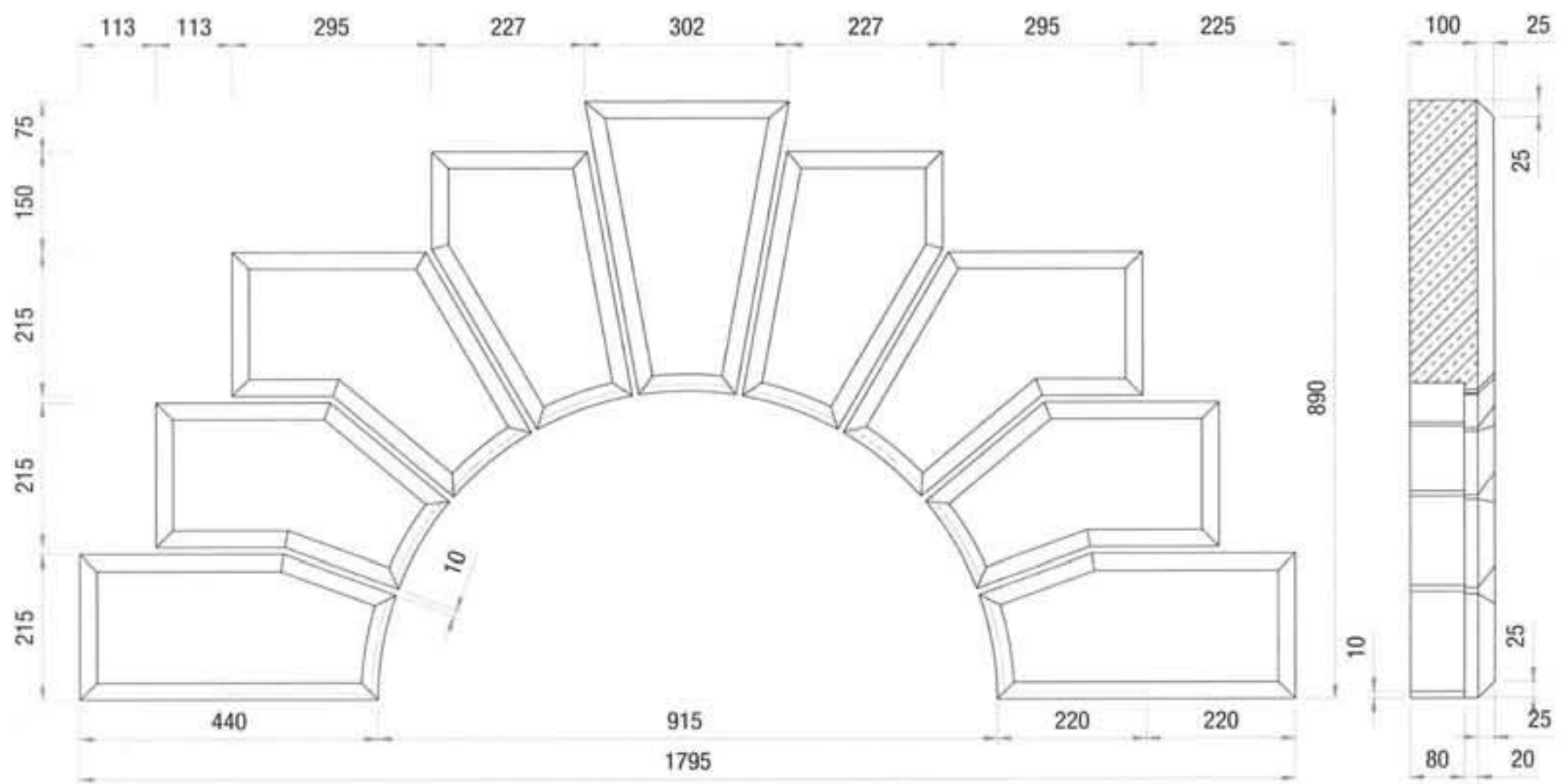

Total Weight: 200Kg

VA2

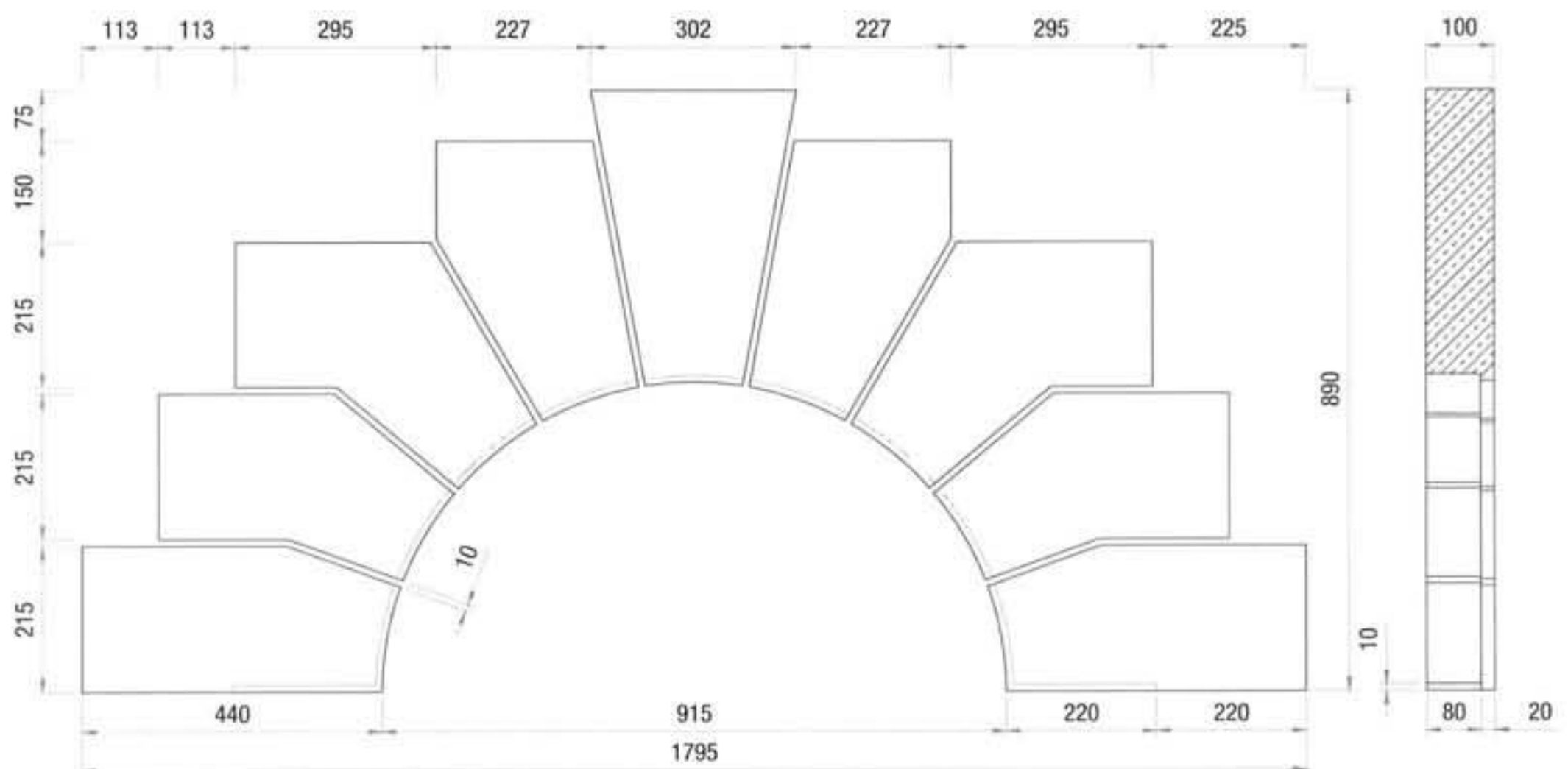

Total Weight: 170Kg

Archstones



AH

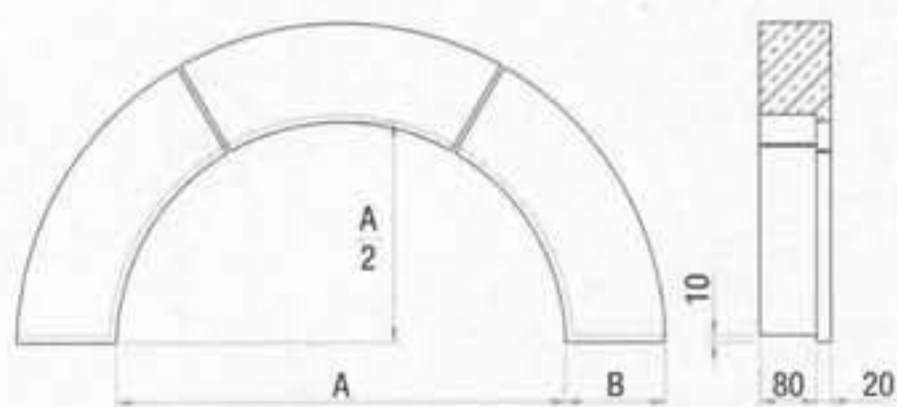

Code	A	B	Weight (kg)
AH1	630	140	36
AH2	630	215	61
AH3	915	140	50
AH4	915	215	81
AH5	1200	140	63
AH6	1200	215	102

AH

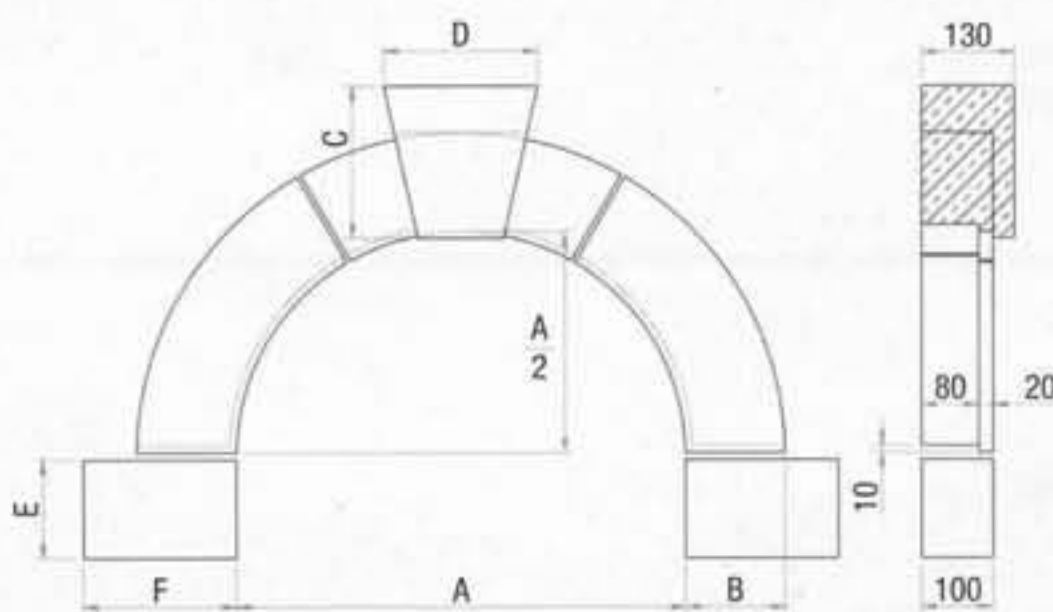

Kit Code	Archstone				Keystone				Kneeler			
	Code	A	B	Weight (kg)	Code	C	D	Weight (kg)	Code	E	F	Weight (kg)
AH7	AH1	630	140	36	H1CK	215	215	5	BK1	140	215	7
AH8	AH2	630	215	61	H3CK	290	300	10	PB1	215	440	20
AH9	AH3	915	140	50	H1CK	215	215	5	BK1	140	215	7
AH10	AH4	915	215	81	H3CK	290	300	10	PB1	215	440	20
AH11	AH5	1200	140	63	H1CK	215	215	5	BK1	140	215	7
AH12	AH6	1200	215	102	H3CK	290	300	10	PB1	215	440	20

AH

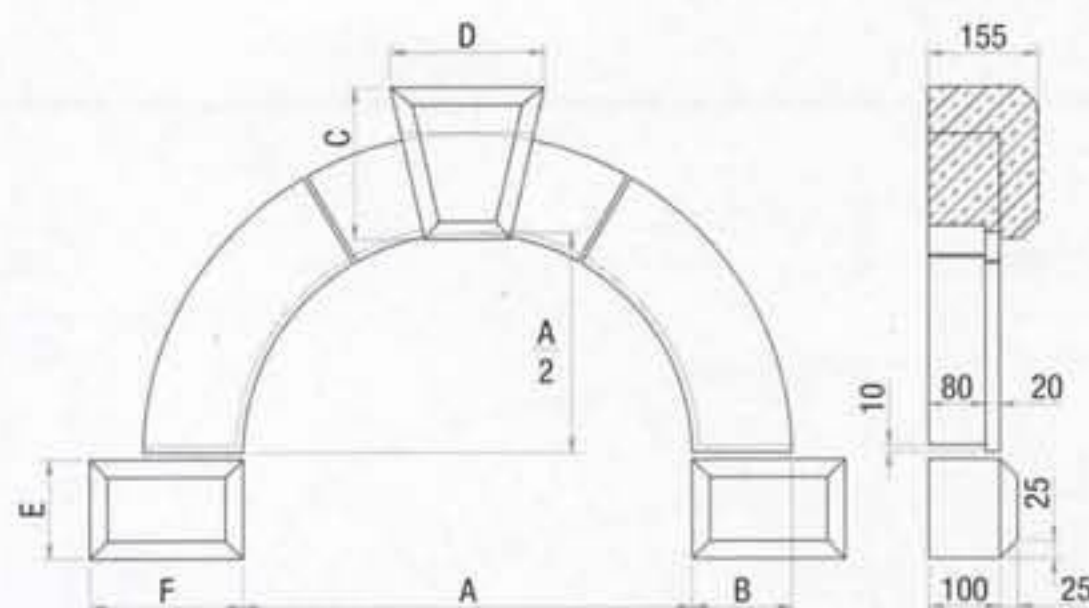

Kit Code	Archstone				Keystone				Kneeler			
	Code	A	B	Weight (kg)	Code	C	D	Weight (kg)	Code	E	F	Weight (kg)
AH13	AH1	630	140	36	CK1	215	215	7	CB7	140	215	8
AH14	AH2	630	215	61	CK3	290	300	12	CB5	215	440	25
AH15	AH3	915	140	50	CK1	215	215	7	CB7	140	215	8
AH16	AH4	915	215	81	CK3	290	300	12	CB5	215	440	25
AH17	AH5	1200	140	63	CK1	215	215	7	CB7	140	215	8
AH18	AH6	1200	215	102	CK3	290	300	12	CB5	215	440	25



Archstones

AH19, AH20 and AH21 use clip over keystones.

AH19

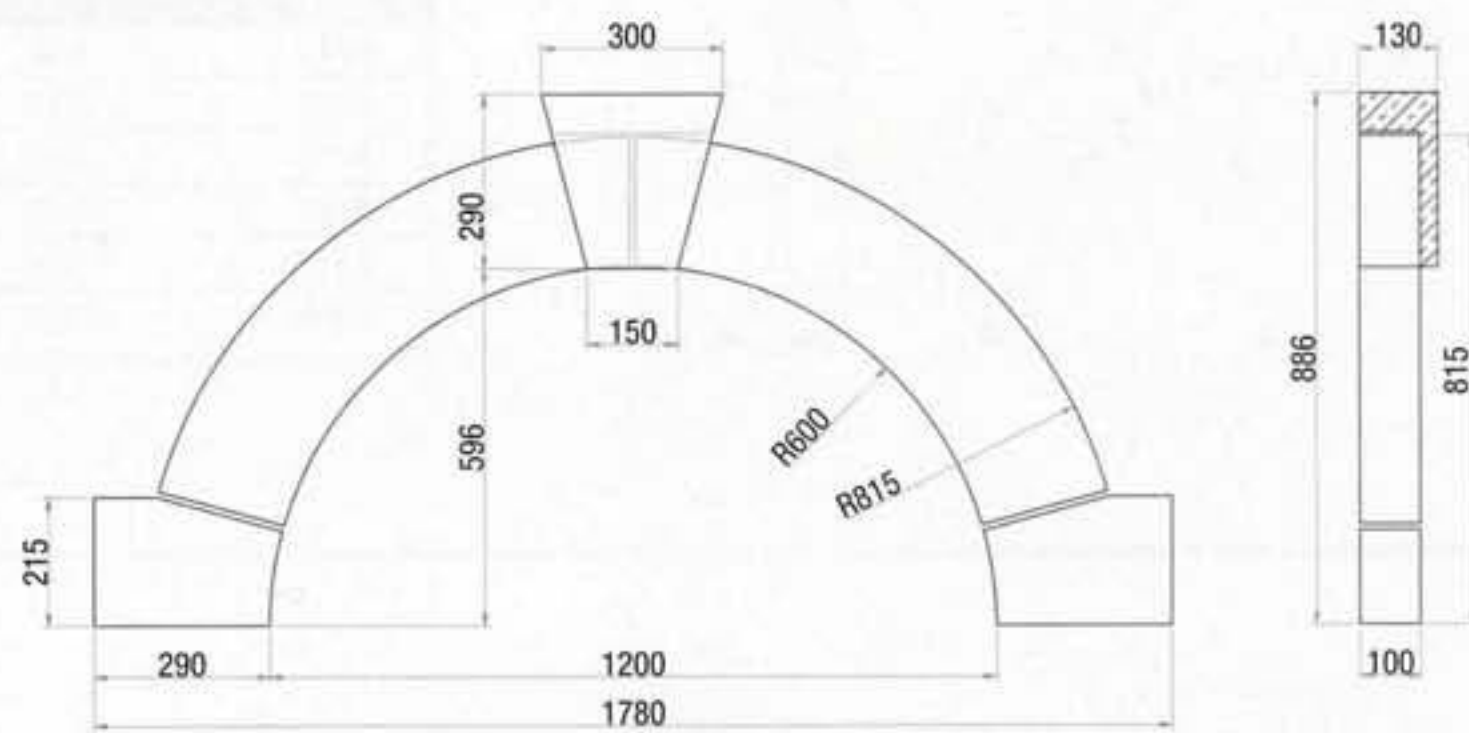

Total Weight: 117Kg

AH20

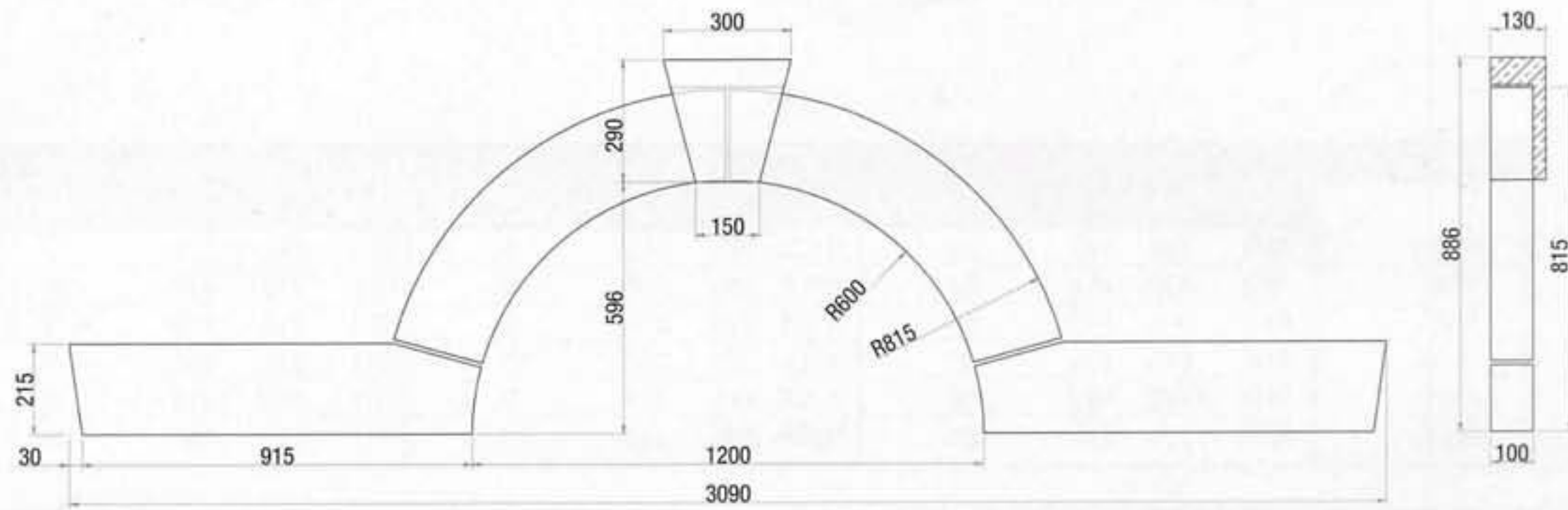

Total Weight: 175Kg

AH21

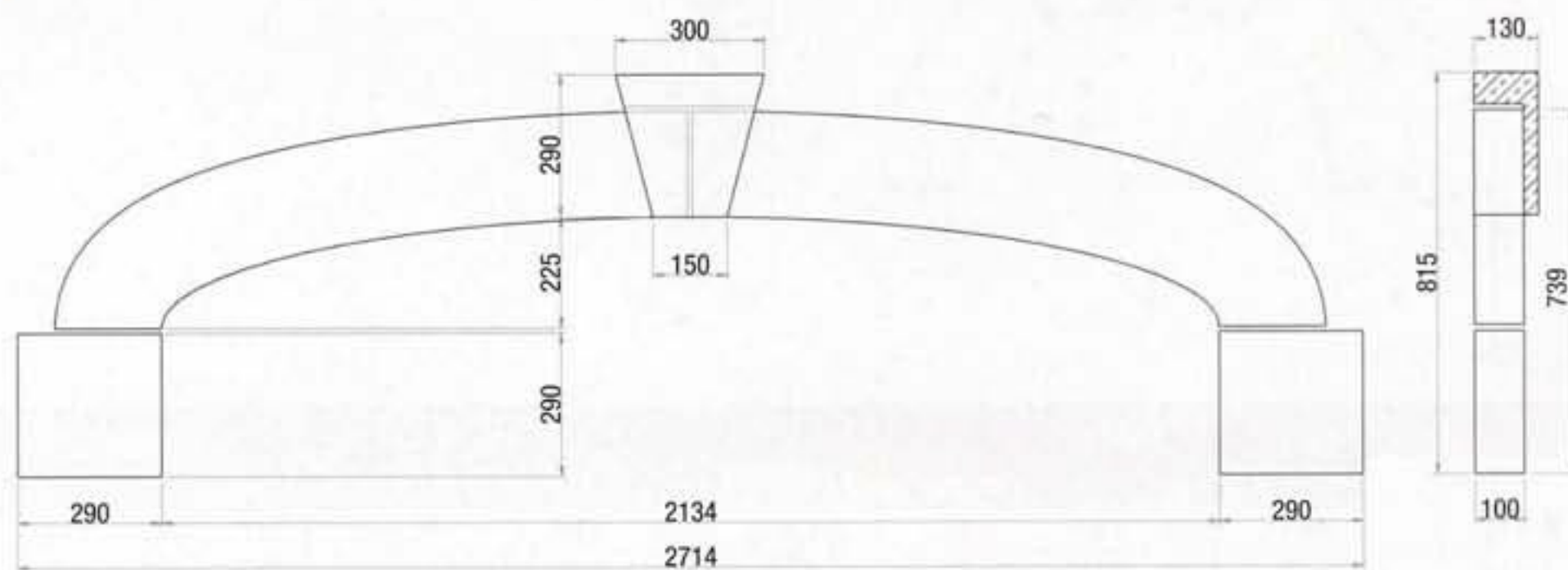

Total Weight: 158Kg

Keystones



H1CK

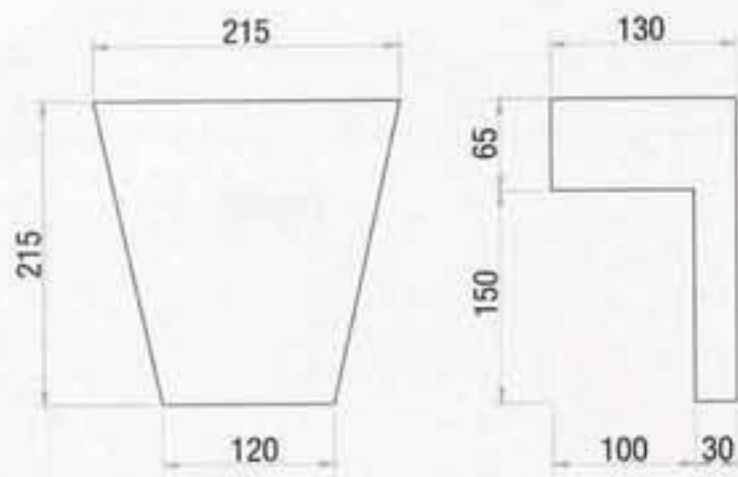

Weight: 5Kg

CK1

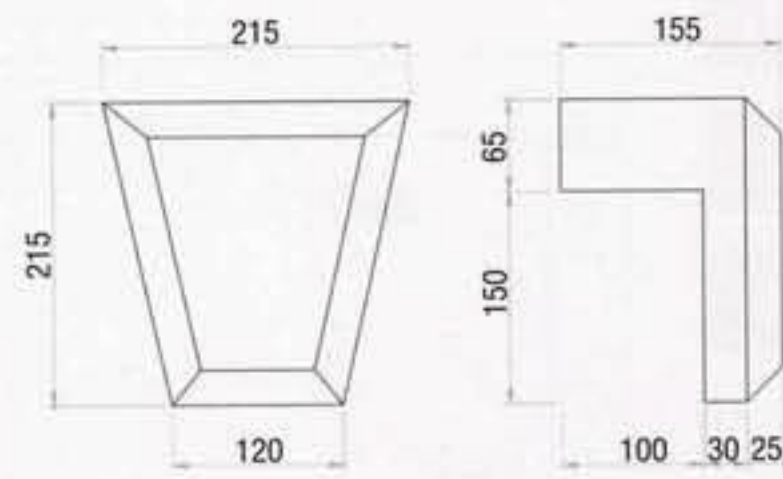

Weight: 6Kg

KS2

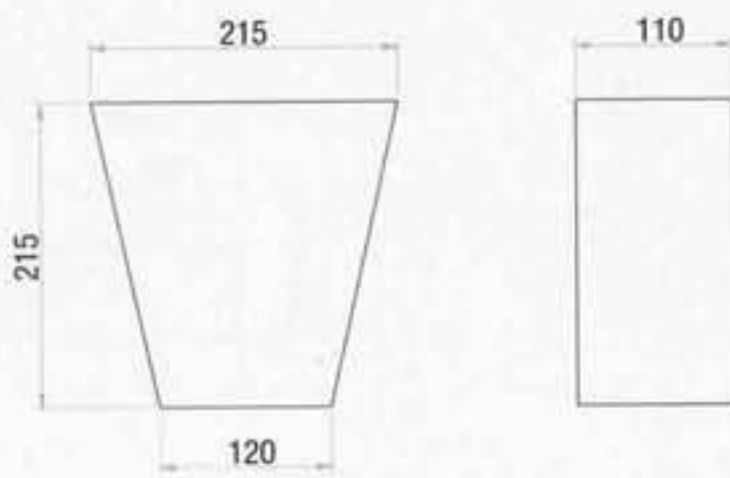

Weight: 10Kg

CK2

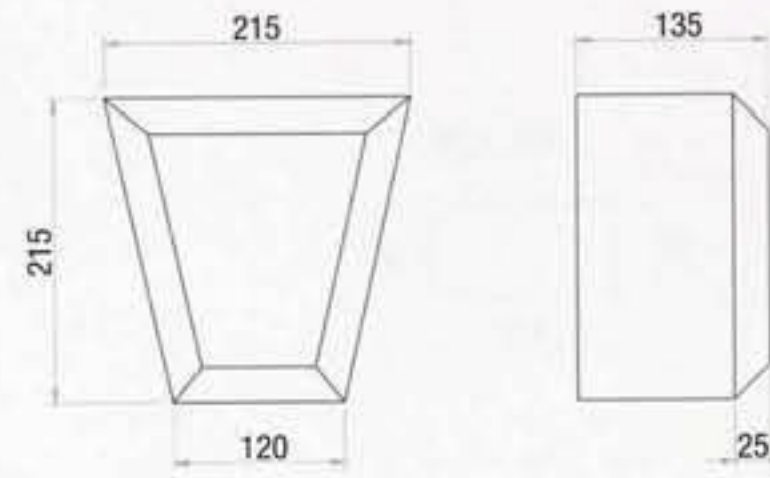

Weight: 11Kg

H3CK

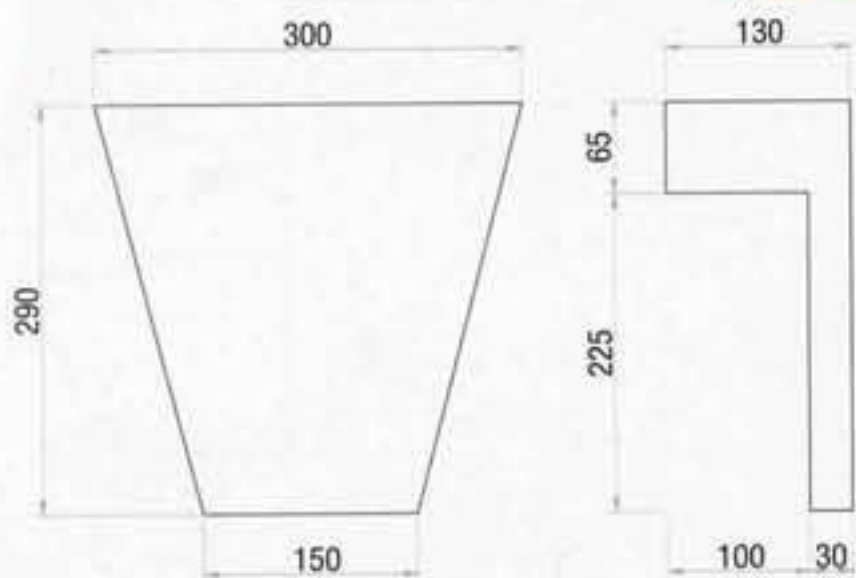

Weight: 8Kg

CK3

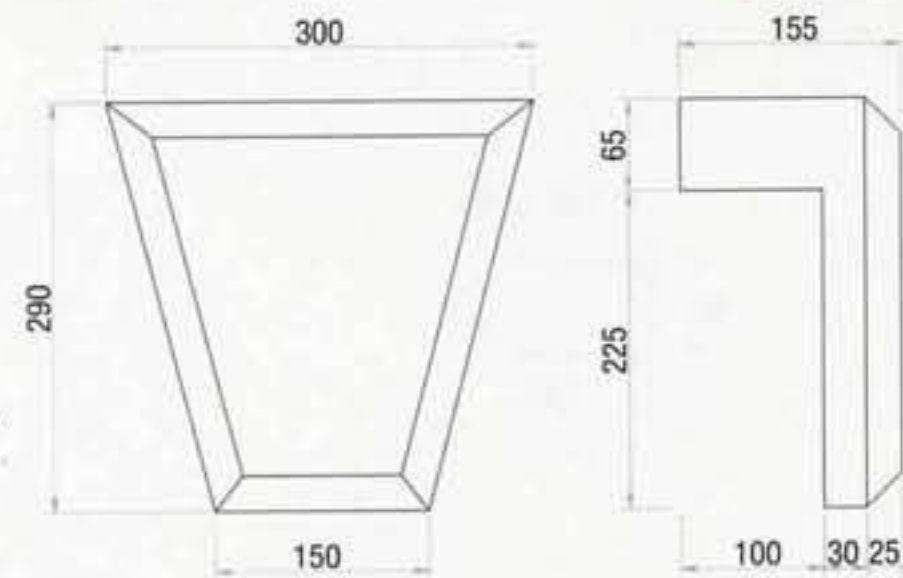

Weight: 11Kg

KS4

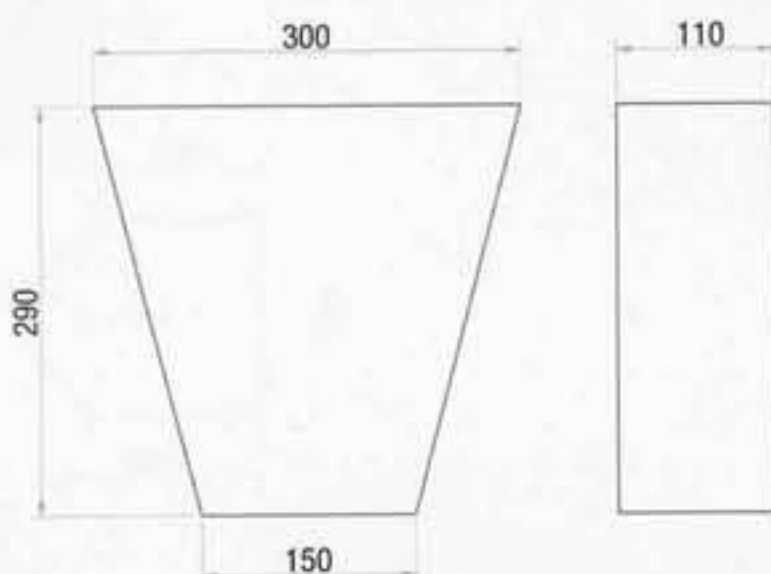

Weight: 18Kg

CK4

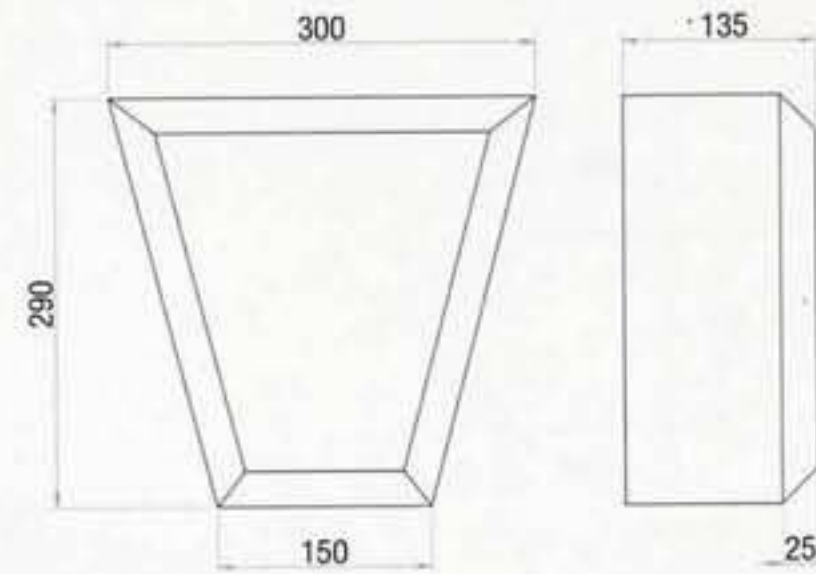

Weight: 21Kg



Label Moulds

Label mould kits are provided in all the profiles shown below. Please state dimensions A and B when ordering.

D90L

D90R

EUL

EUR

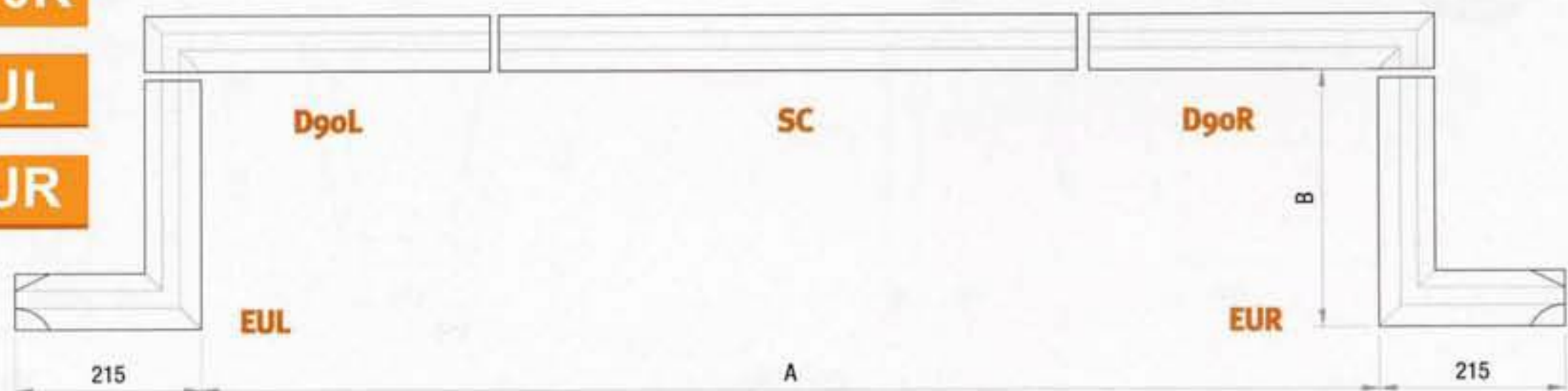

SCC

SCF

SCG

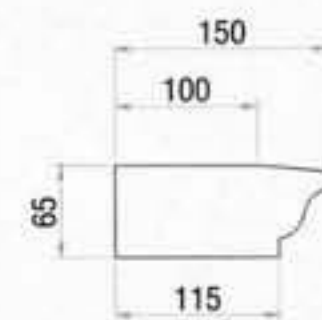
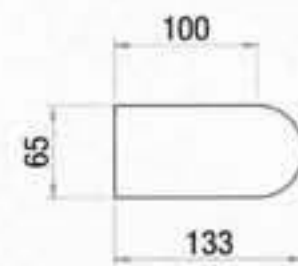
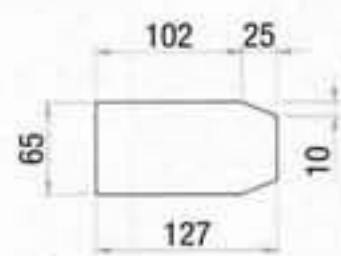

SCH

SCJ

SCR

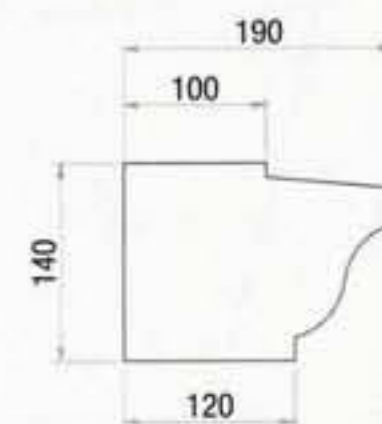
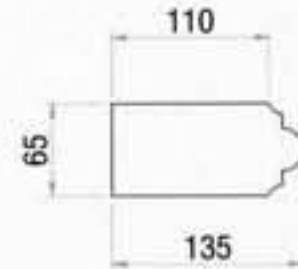
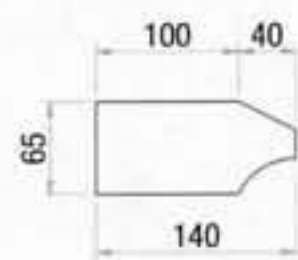

SCS

SCU

SCW

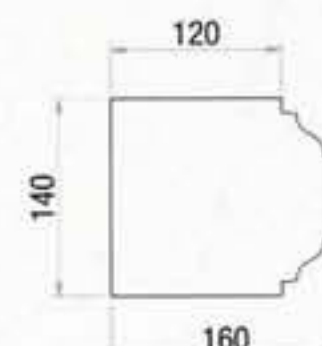
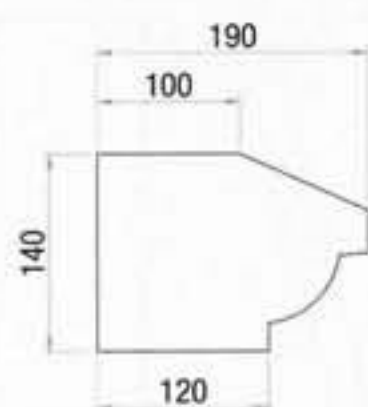

Label Moulds



Left **EUL**

Right **EUR**

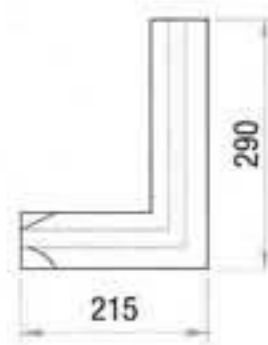

STOP END
LABEL RETURN
TO THE LEFT

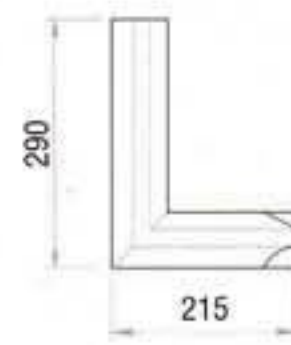

STOP END
LABEL RETURN
TO THE RIGHT

Left **D90L**

Right **D90R**

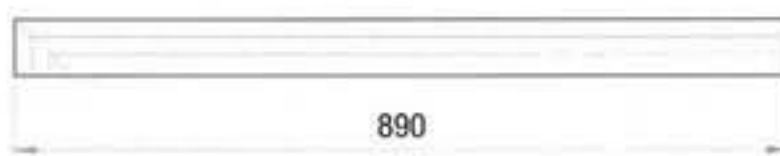

DOWN 90° RETURN
TO THE LEFT

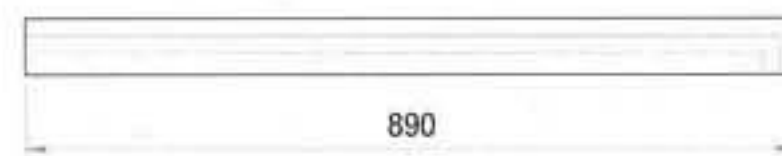

DOWN 90° RETURN
TO THE RIGHT

Door Surrounds



All door surrounds are supplied with stainless steel dovetail cramp fixings and dowels.

Please state dimension A when ordering.

A Technical Data Sheet showing the recommended installation is available on request.

DS1

DS2

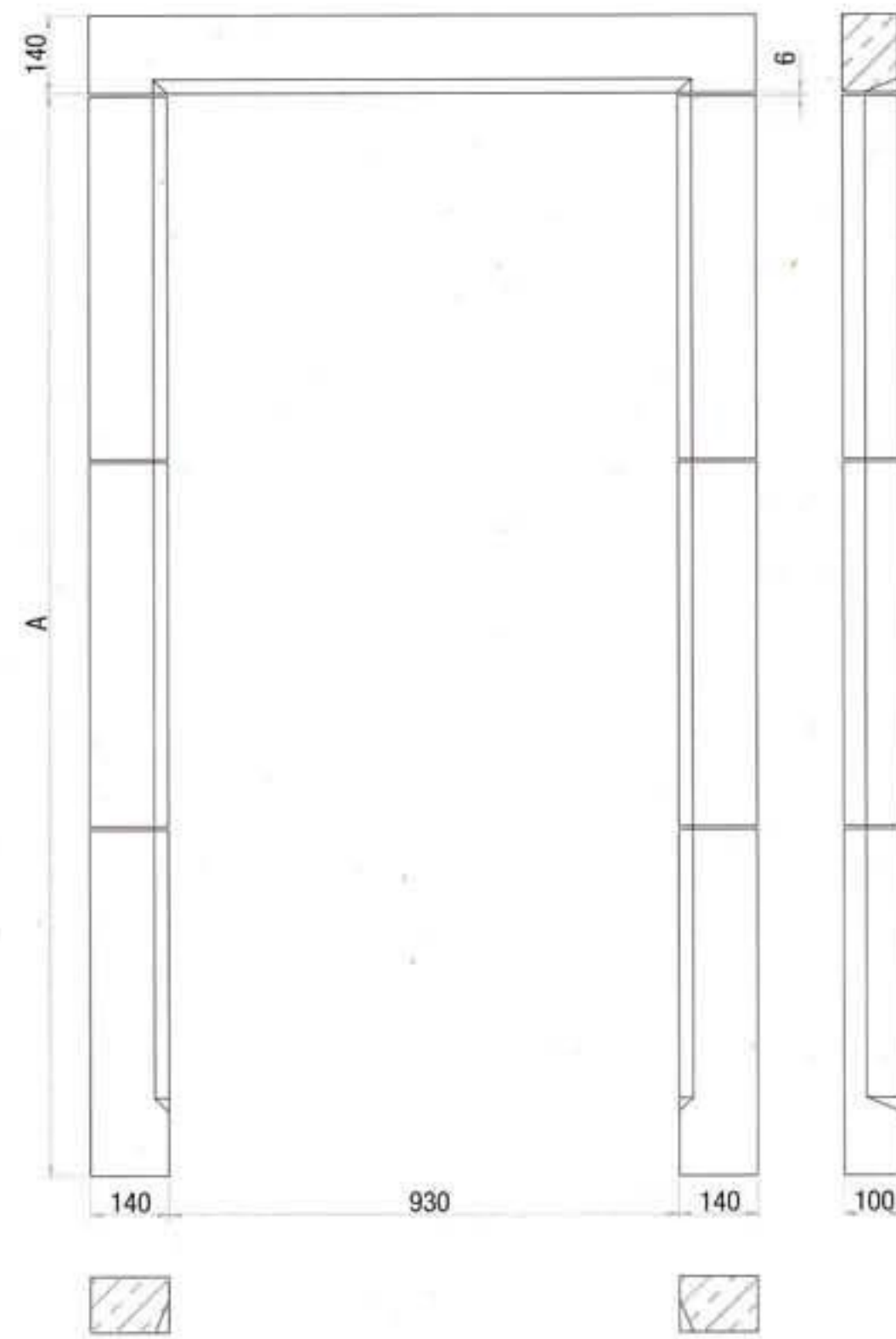
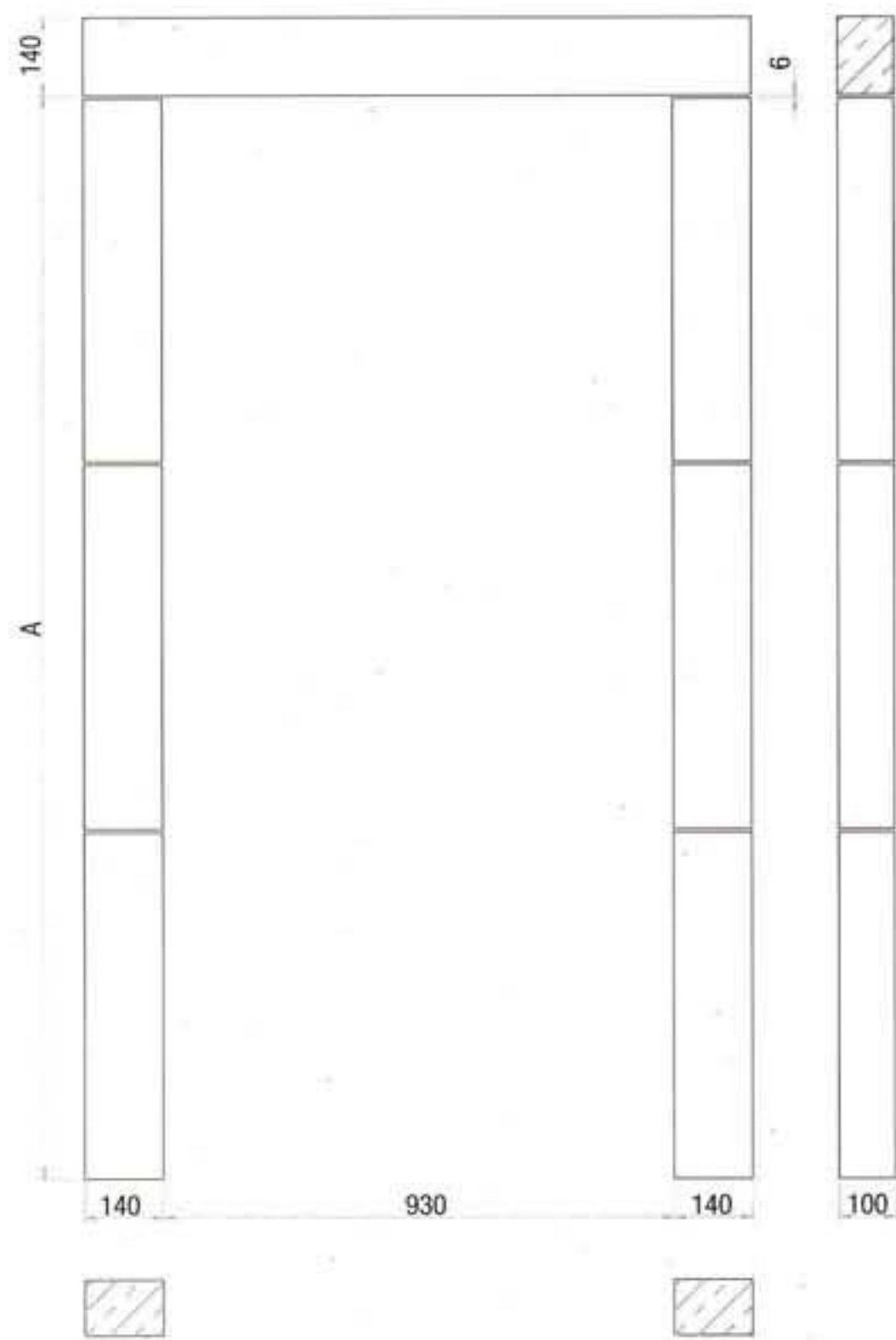

Door Surrounds



All door surrounds are supplied with stainless steel dovetail cramp fixings and dowels.

Please state dimension A when ordering.

A Technical Data Sheet showing the recommended installation is available on request.

DS3

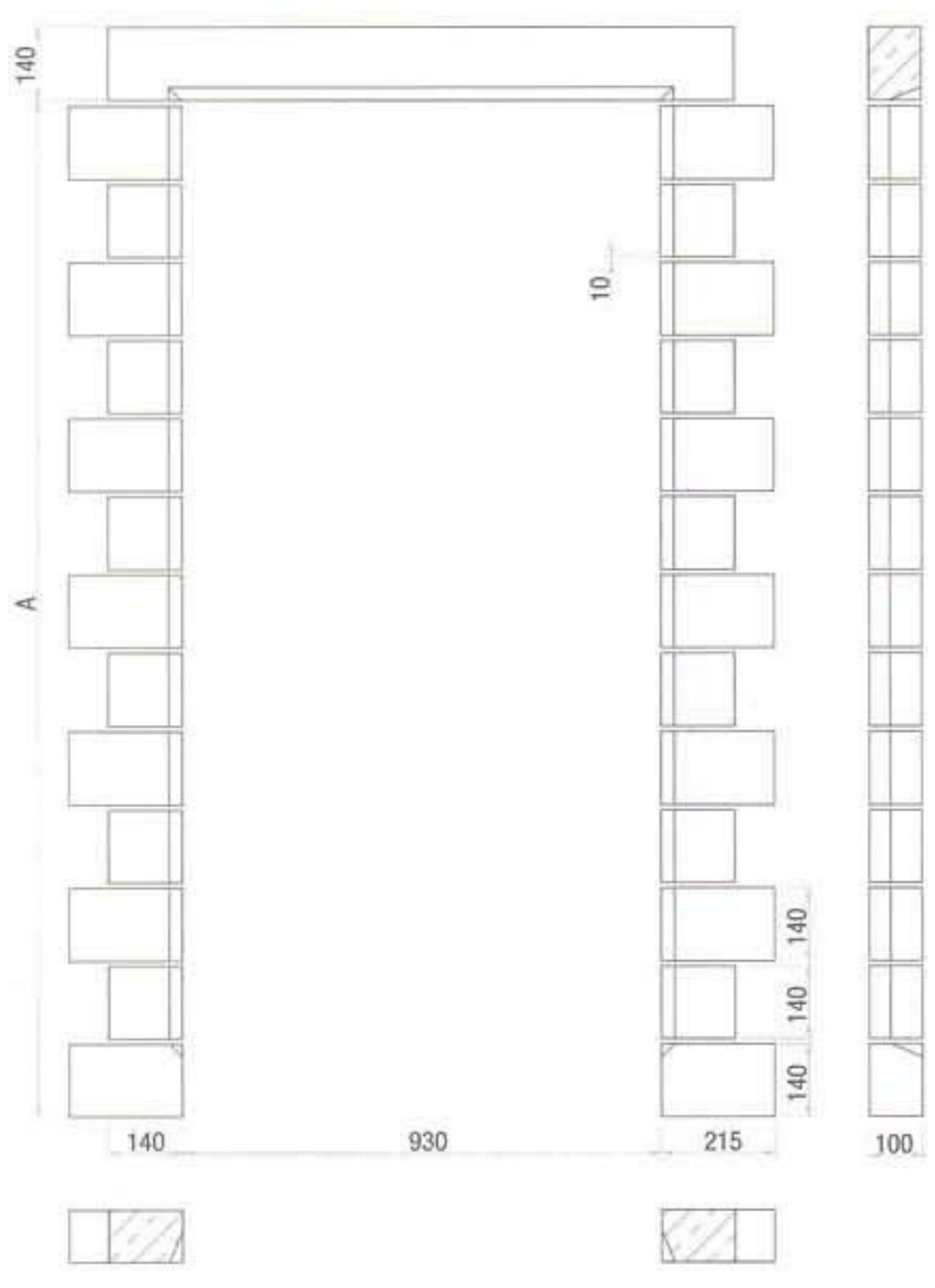

DS4

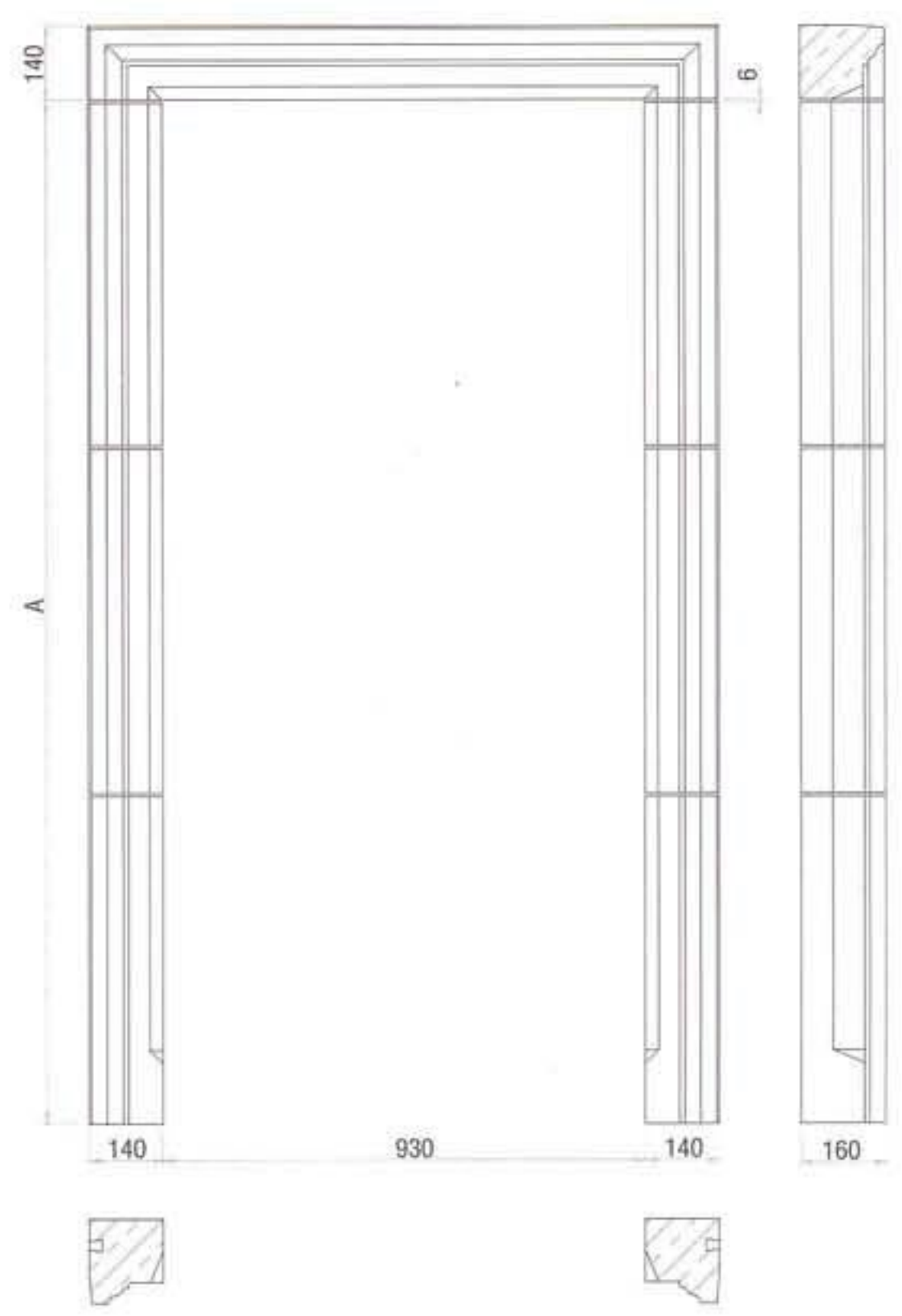

Door Surrounds



All door surrounds are supplied with stainless steel dovetail cramp fixings and dowels.

Please state dimension A when ordering.

A Technical Data Sheet showing the recommended installation is available on request.

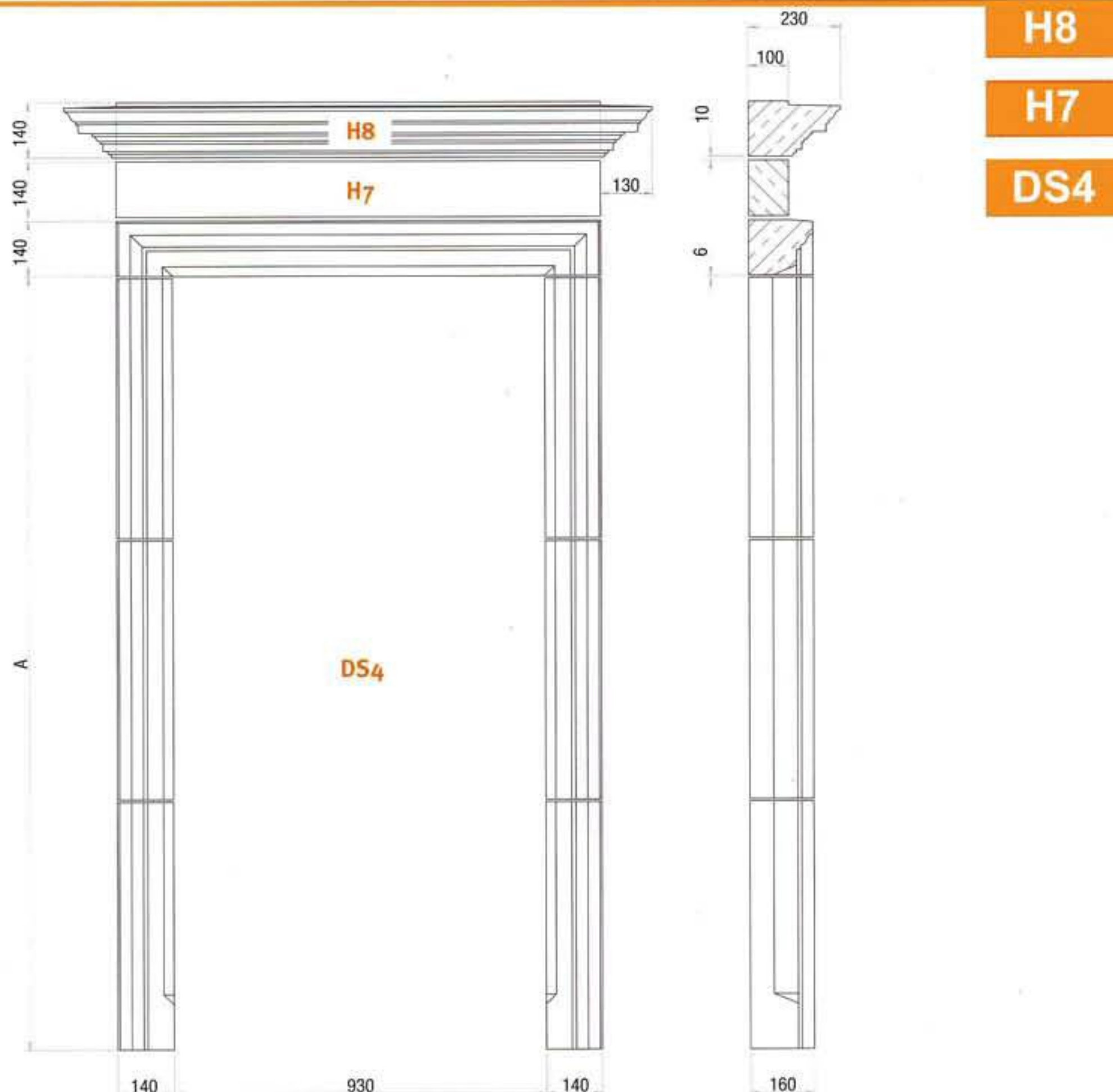
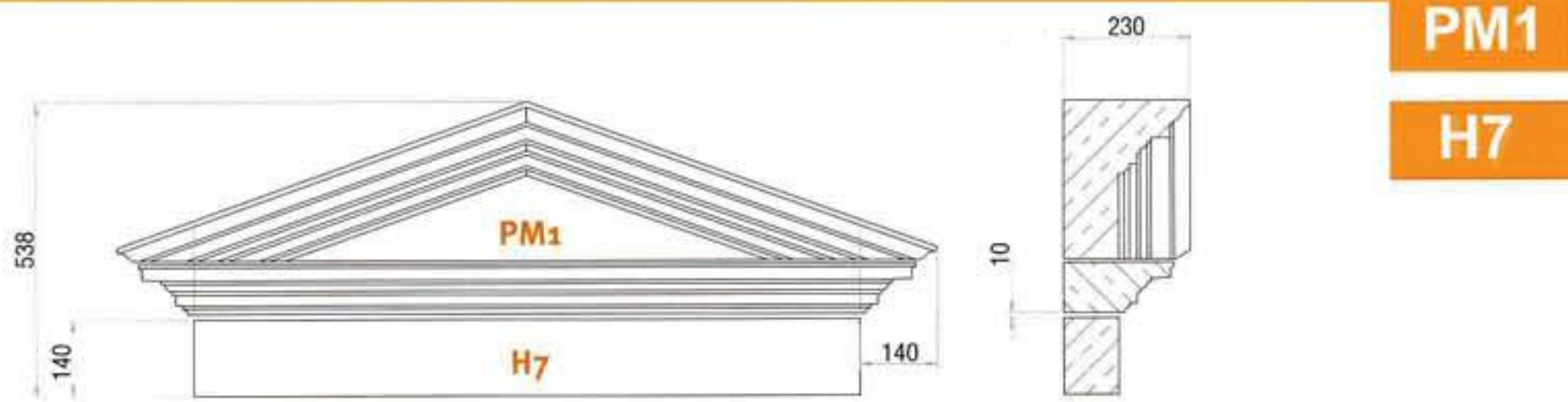



Door Surrounds

A relieving lintel will be required to carry structure above and to provide support for the centre of the arch.

A Technical Data Sheet showing the recommended installation is available on request.

PO1

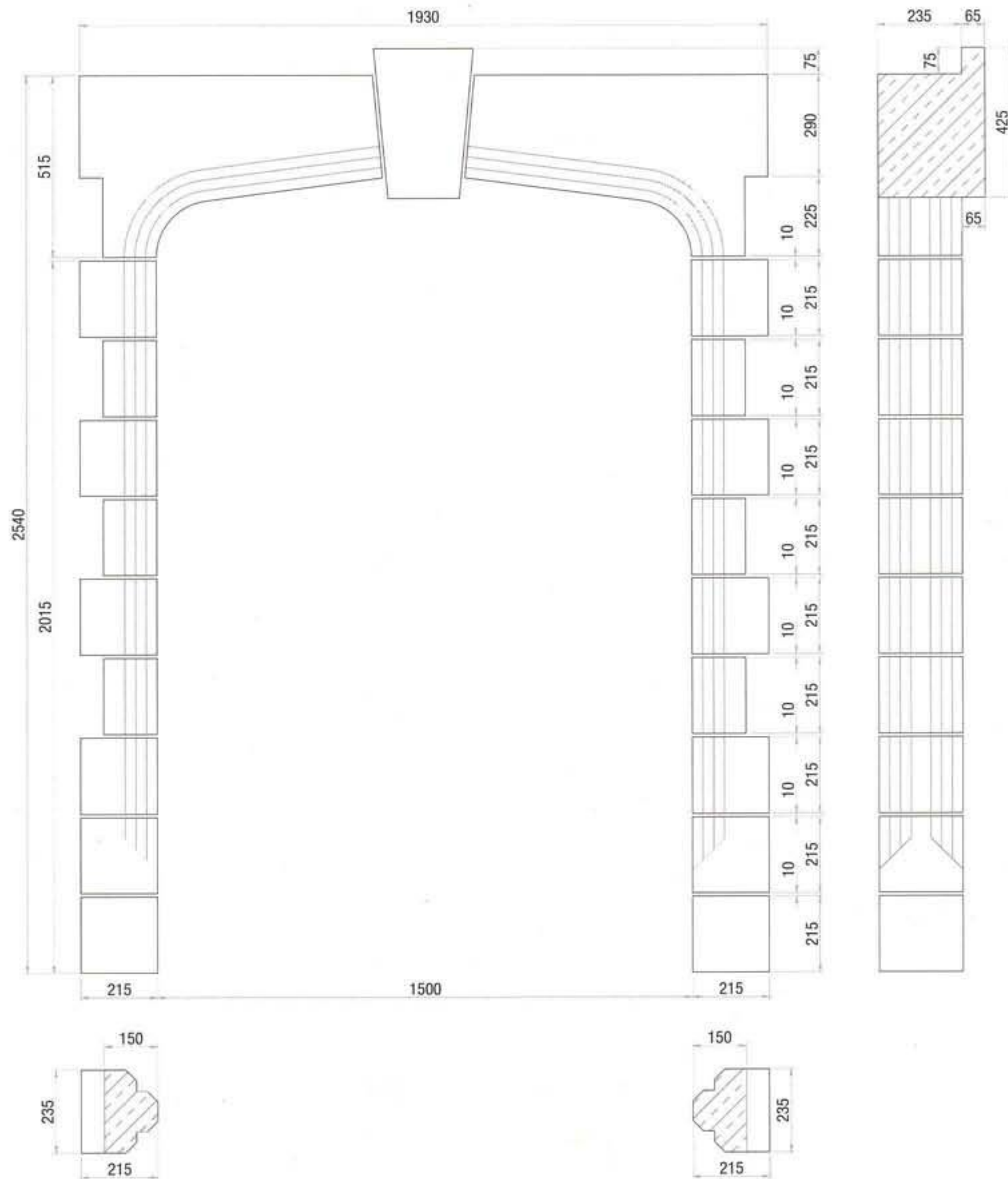

Porticos



All porticos can be supplied with the following options: -
 Solid or hollow core columns
 Steel frame or in situ concrete structure
 Choice of capitals, columns, architrave and balustrading.

Please state dimensions A and B when ordering.
 A Technical Data Sheet showing the recommended installation is available on request.

PT1

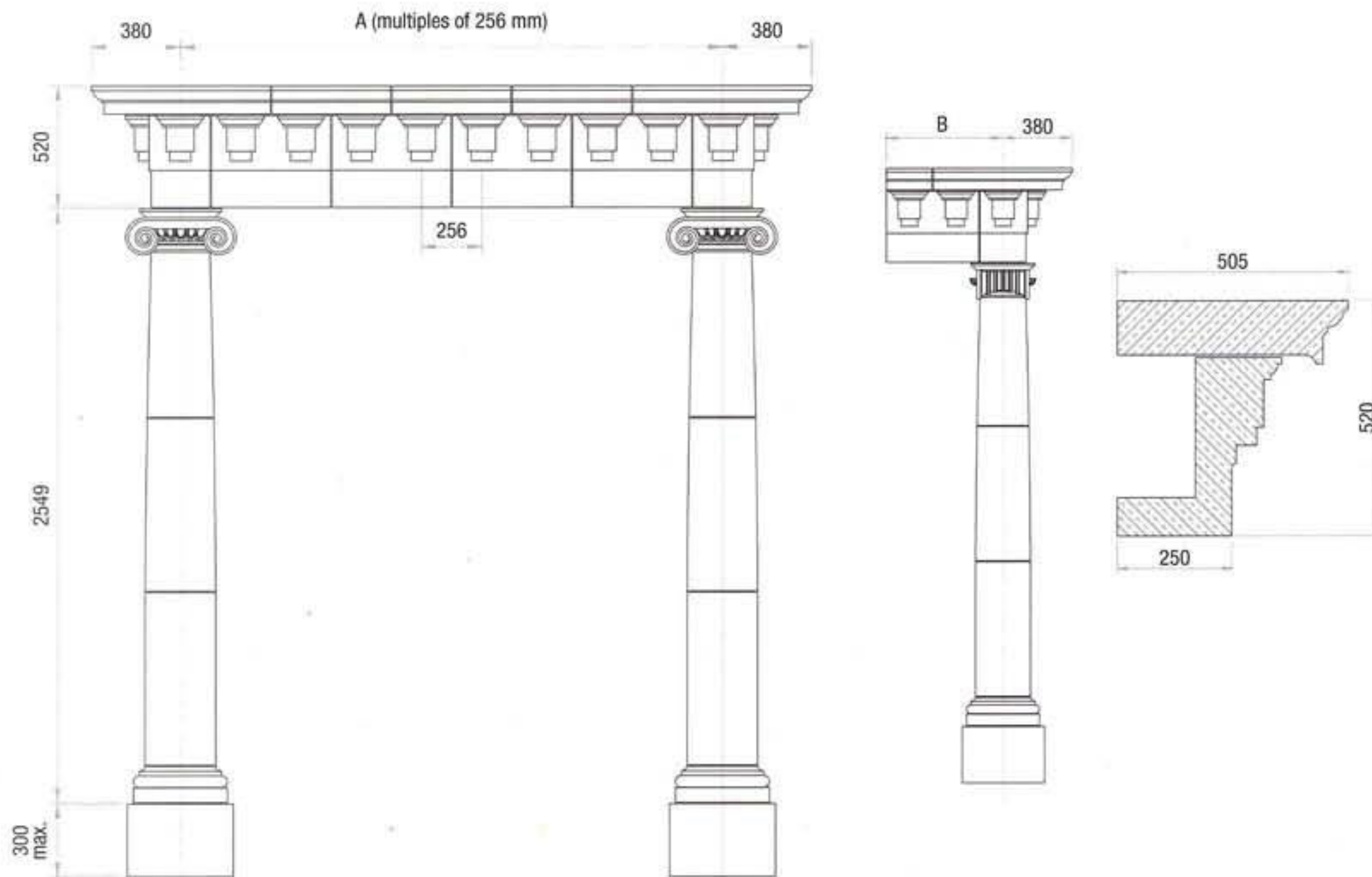

PT2

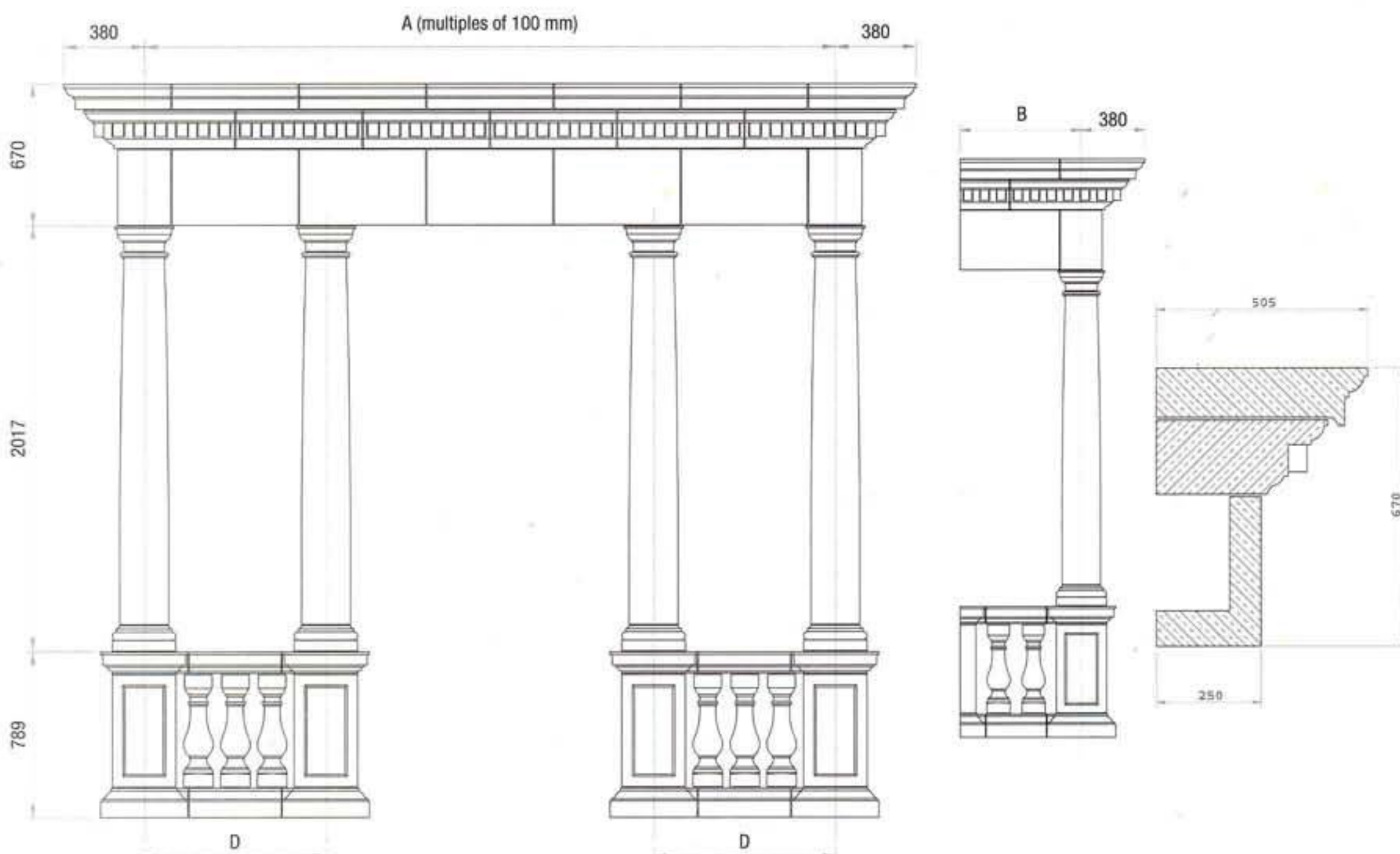



Porticos

All porticos can be supplied with the following options: -
 Solid or hollow core columns
 Steel frame or in situ concrete structure
 Choice of capitals, columns, architrave and balustrading.

Please state dimensions A and B when ordering.
 A Technical Data Sheet showing the recommended installation is available on request.

PT3

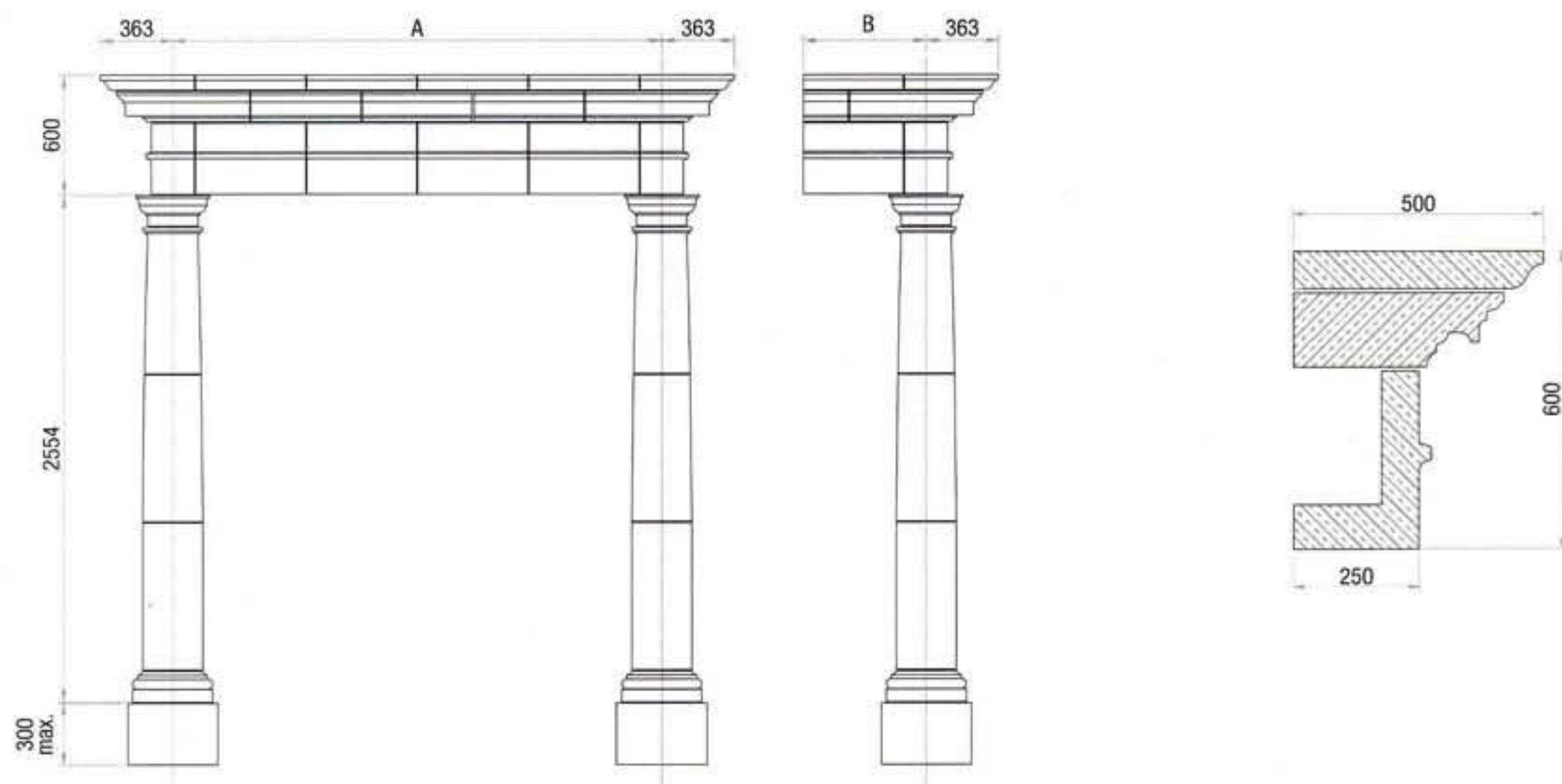

PT4

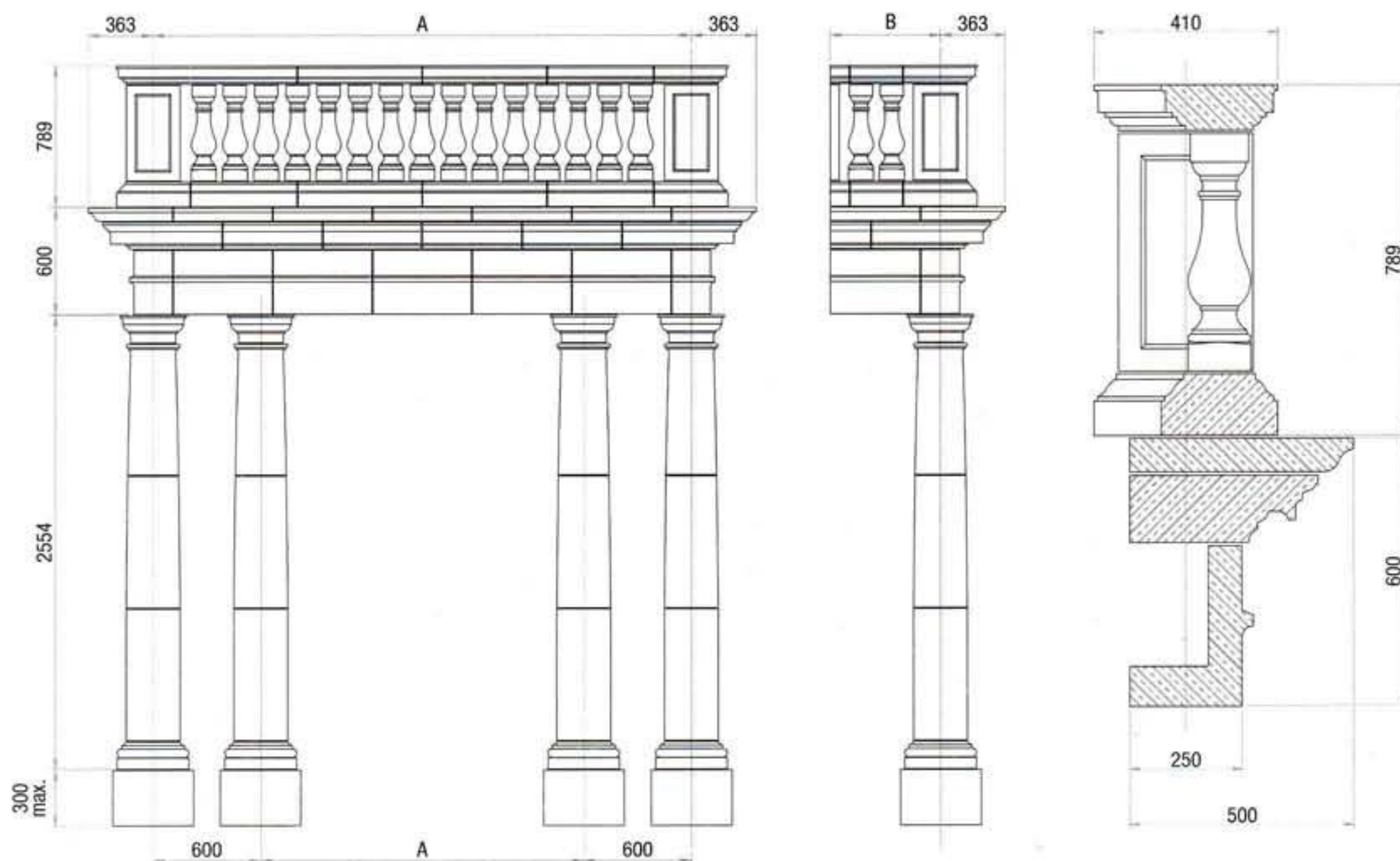

Porticos



All porticos can be supplied with the following options: -
Solid or hollow core columns
Steel frame or in situ concrete structure
Choice of capitals, columns, architrave and balustrading.

Please state dimensions A and B when ordering.

A Technical Data Sheet showing the recommended installation is available on request.

PT5

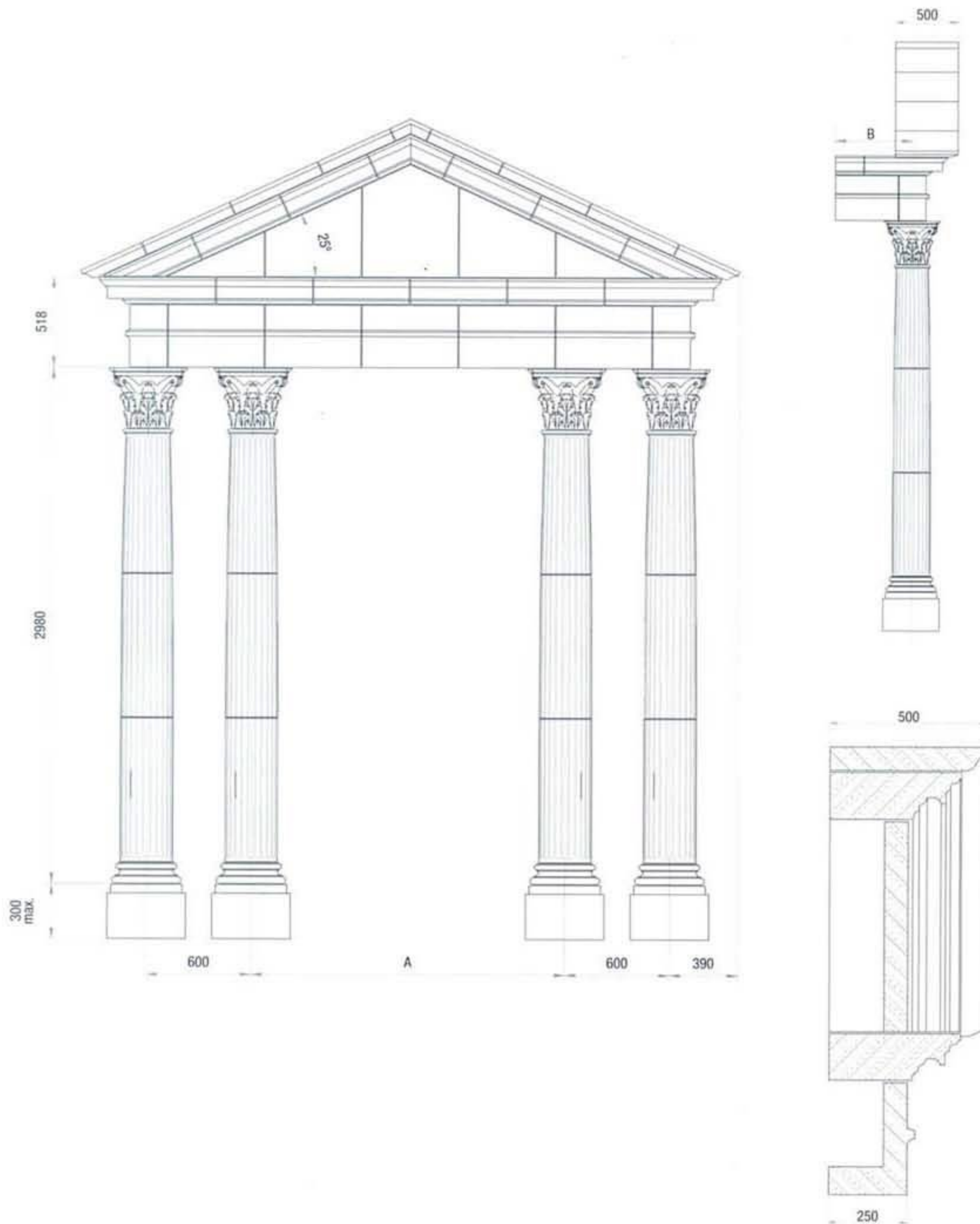



Porticos

All porticos can be supplied with the following options: -
Solid or hollow core columns
Steel frame or in situ concrete structure
Choice of capitals, columns, architrave and balustrading.

Please state dimensions A and B when ordering.
A Technical Data Sheet showing the recommended installation is available on request.

PT6

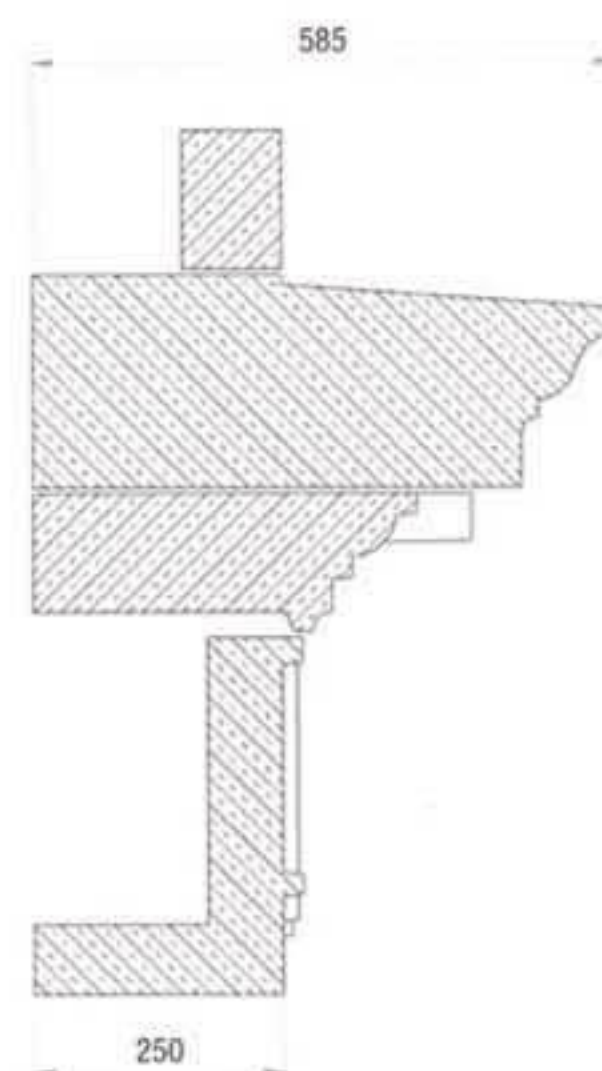
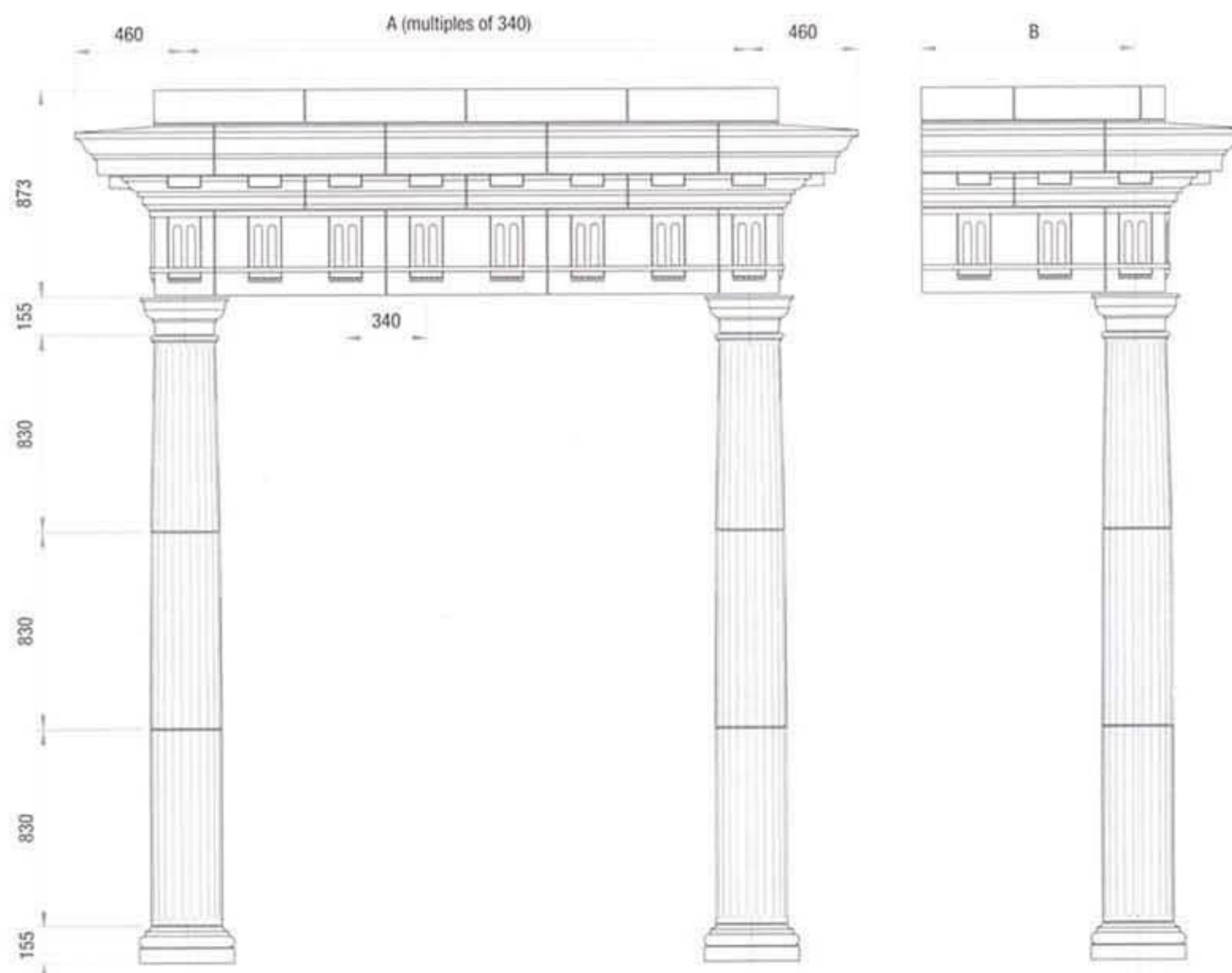

Quoins



Plain Quoin

PQ

Code	A	B	C	E	Weight (kg)
PQ1*	440	215	215	100	25
PQ2*	444	219	219	100	26
PQ3*	440	290	215	100	34
PQ4*	444	294	219	100	35
PQ5*	594	294	294	100	49
PQ6	440	215	215	120	28
PQ7	444	219	219	120	29
PQ8	440	290	215	120	38
PQ9	444	294	219	120	39
PQ10	594	294	294	120	55

* denotes products in The Homestyle Range

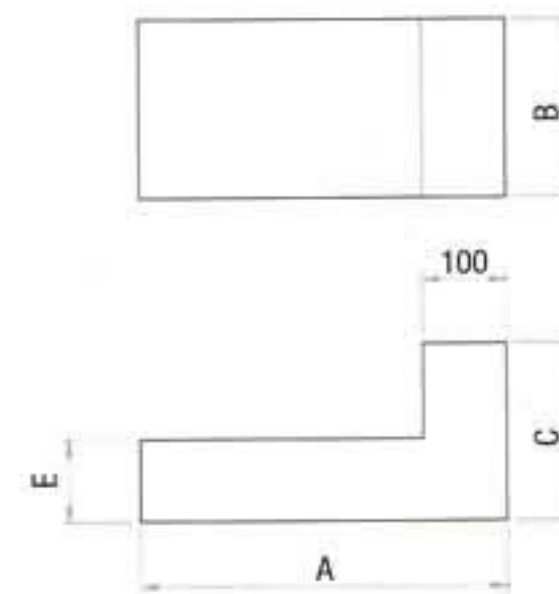

Chamfered Quoin

CHQ

Code	A	B	C	D	E	Weight (kg)
CHQ2*	328	215	215	18	100	25
CHQ4*	440	290	215	25	100	41
CHQ5*	440	215	215	25	100	32
CHQ7	328	215	215	18	120	27
CHQ9	440	290	215	25	120	46
CHQ10	440	215	215	25	120	36

* denotes products in The Homestyle Range

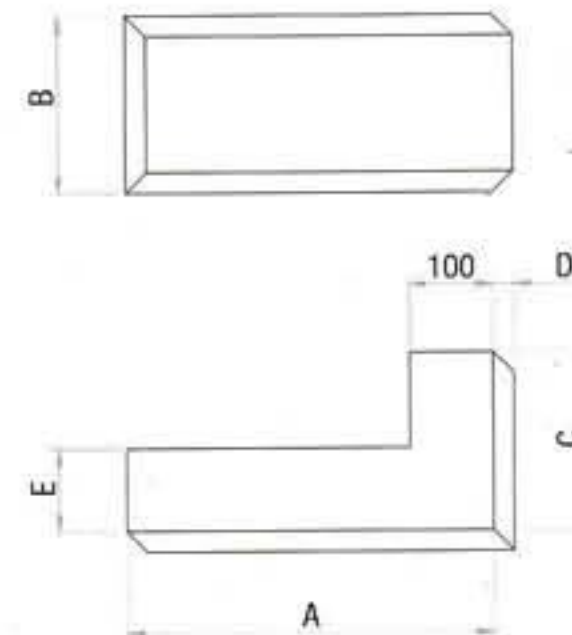

Reticulated Quoin

RQ

Code	A	B	C	D	E	Weight (kg)
RQ1	440	290	215	25	100	41
RQ2	440	215	215	25	100	32
RQ3	440	290	215	25	120	46
RQ4	440	215	215	25	120	36

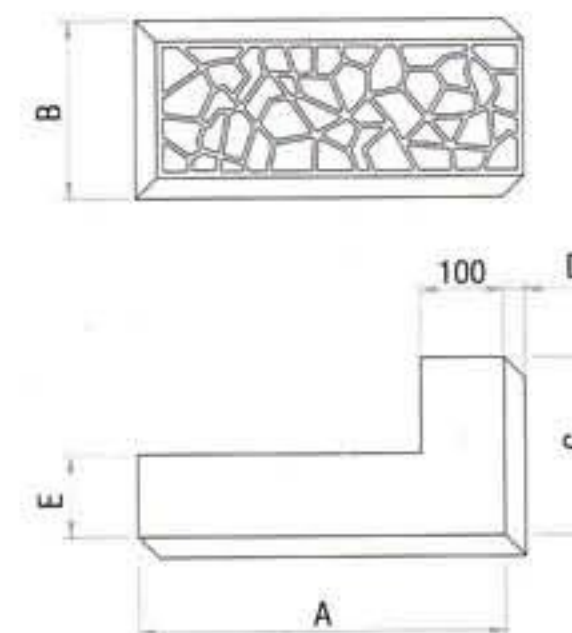



Quoins

VQ Vermiculated Quoin

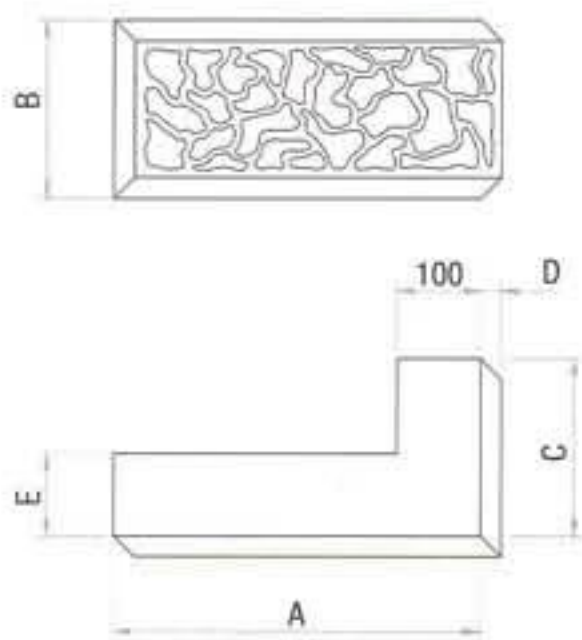

Code	A	B	C	D	E	Weight (kg)
VQ1	440	290	215	25	100	41
VQ2	440	215	215	25	100	32
VQ3	440	290	215	25	120	46
VQ4	440	215	215	25	120	36

AQ-45 Angled Quoin

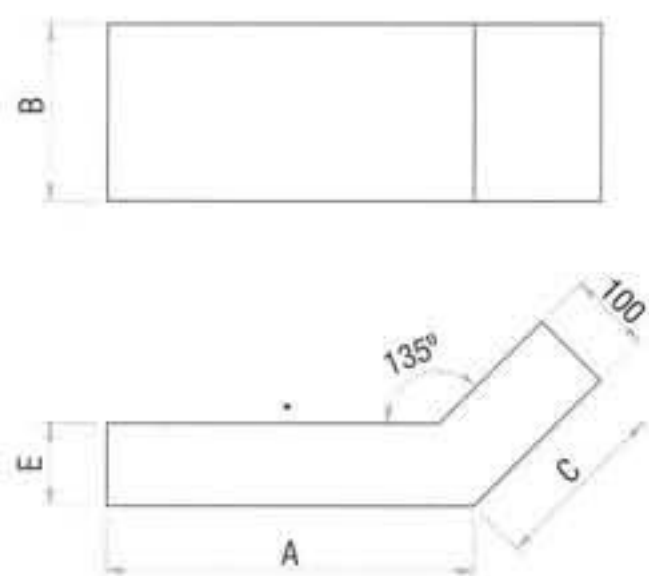

Code	A	B	C	D	Weight (kg)
AQ1-45	440	215	215	100	28
AQ2-45	444	219	219	100	29
AQ3-45	440	290	215	100	38
AQ4-45	444	294	219	100	39
AQ5-45	594	294	294	100	52
AQ6-45	440	215	215	120	33
AQ7-45	444	219	219	120	34
AQ8-45	440	290	215	120	45
AQ9-45	444	294	219	120	46
AQ10-45	594	294	294	120	62

CQ-45 Angled Chamfered Quoin

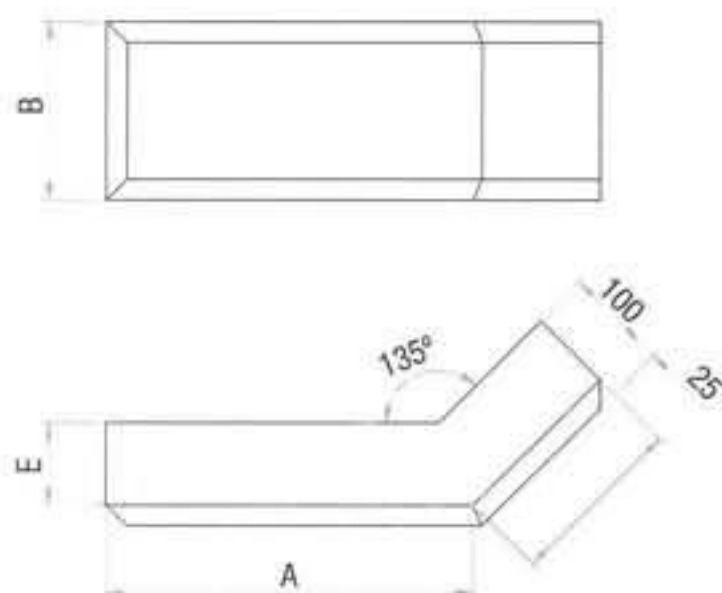

Code	A	B	C	D	E	Weight (kg)
CQ2-45	328	215	215	18	100	28
CQ4-45	440	290	215	25	100	46
CQ5-45	440	215	215	25	100	36
CQ7-45	328	215	215	18	120	30
CQ9-45	440	290	215	25	120	51
CQ10-45	440	215	215	25	120	40

Quoins



CHQ11

CHQ12

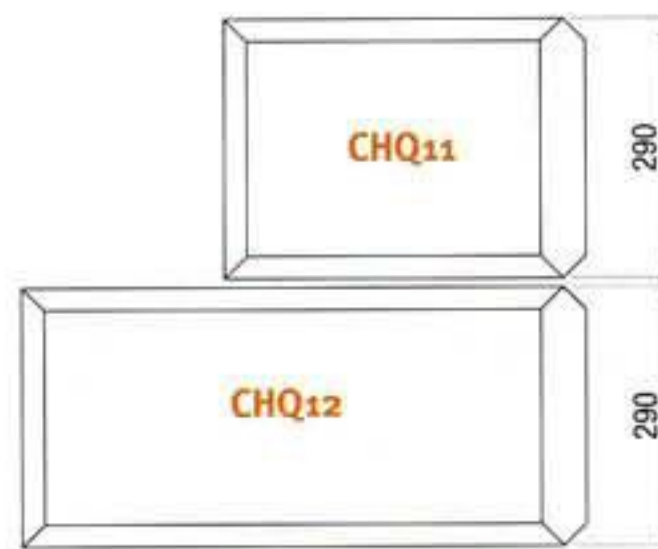

CHQ11

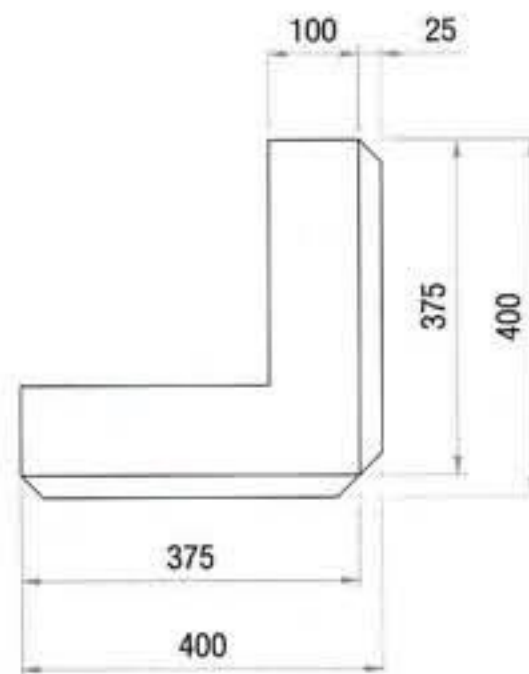

Total Weight: 50Kg

CHQ12

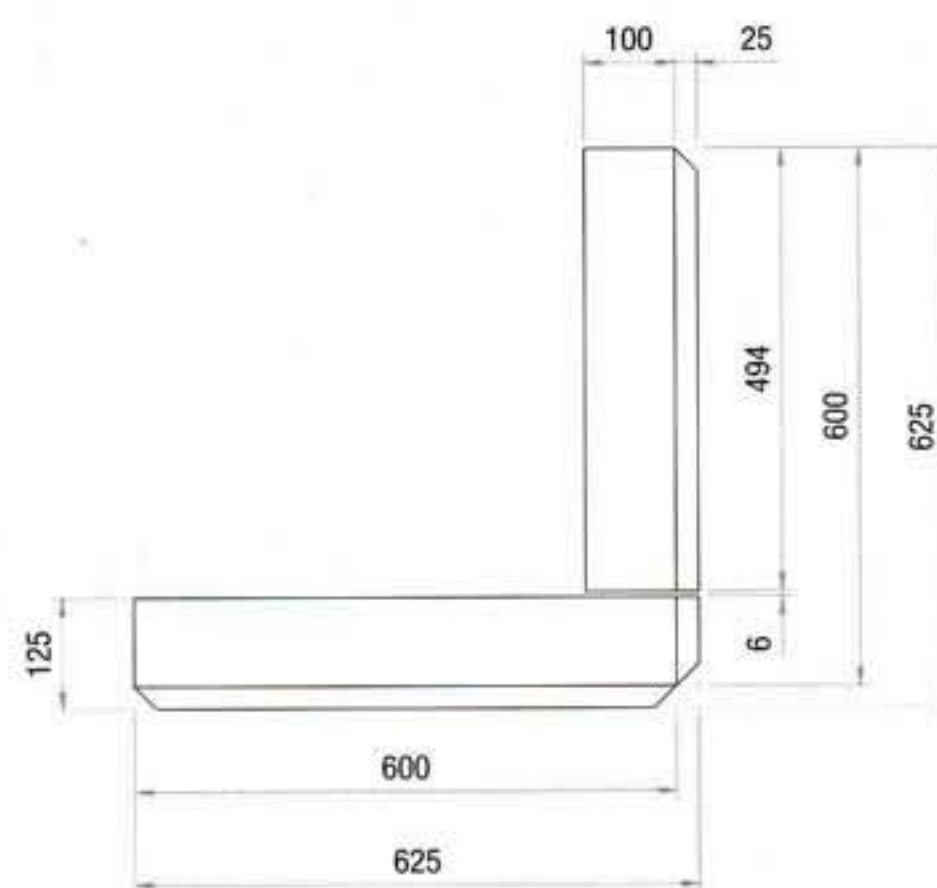

Total Weight: 83Kg



Blocks

Machine made blocks are manufactured to BS 6457 and hand made blocks are manufactured to BS 1217 : 1997. When walling large areas always mix blocks from several packs.

PB

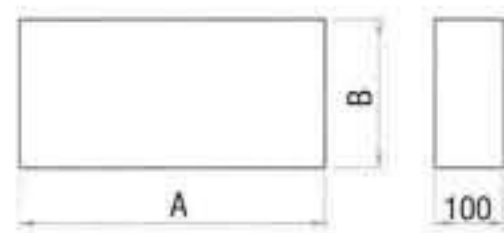

Code	A	B	Weight (kg)
PB1	440	215	20
PB2	444	219	21
PB3	440	290	27
PB4	444	294	28
PB5	594	294	37

RB

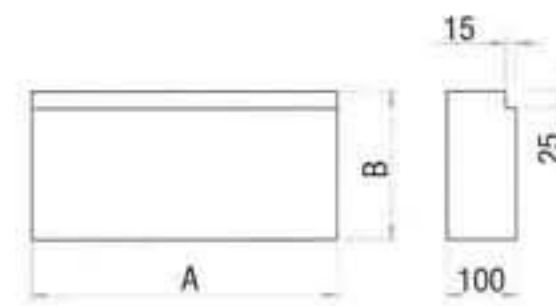

Code	A	B	Weight (kg)
RB1	440	215	20
RB2	444	219	21

RB

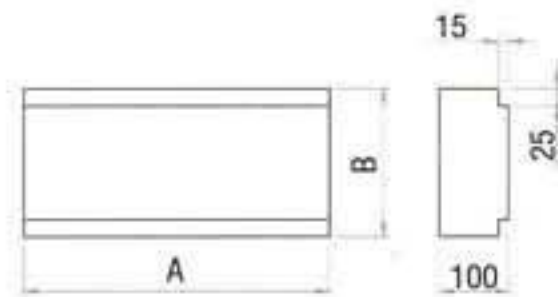

Code	A	B	Weight (kg)
RB3	440	215	20
RB4	444	219	21

CB

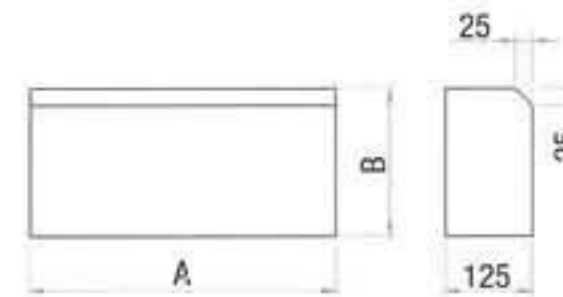

Code	A	B	Weight (kg)
CB1	440	215	25
CB2	444	219	26

CB

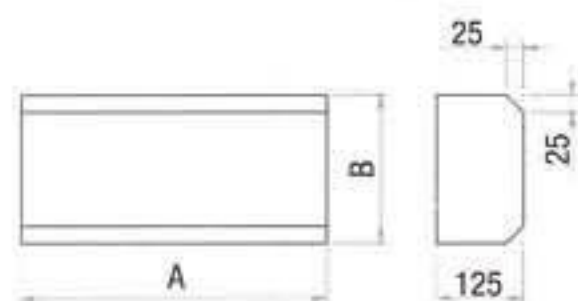

Code	A	B	Weight (kg)
CB3	440	215	25
CB4	444	219	26

CB

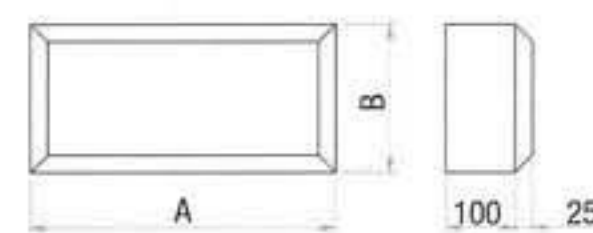

Code	A	B	Weight (kg)
CB5	440	215	25
CB6	444	219	26

Plinth Blocks



PL

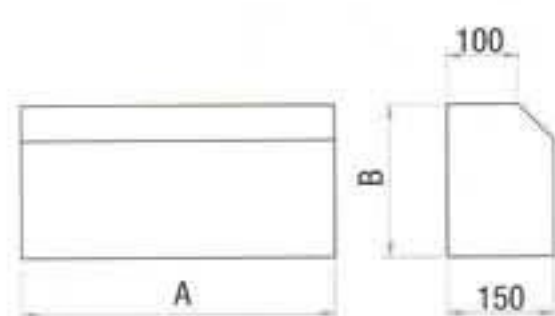

Code	A	B	Weight (kg)
PL6	440	140	18
PL1	440	215	29
PL30*	444	219	30
PL3	440	290	40
PL4	444	294	41
PL5	594	294	54

* denotes product in The Homestyle Range

PLX

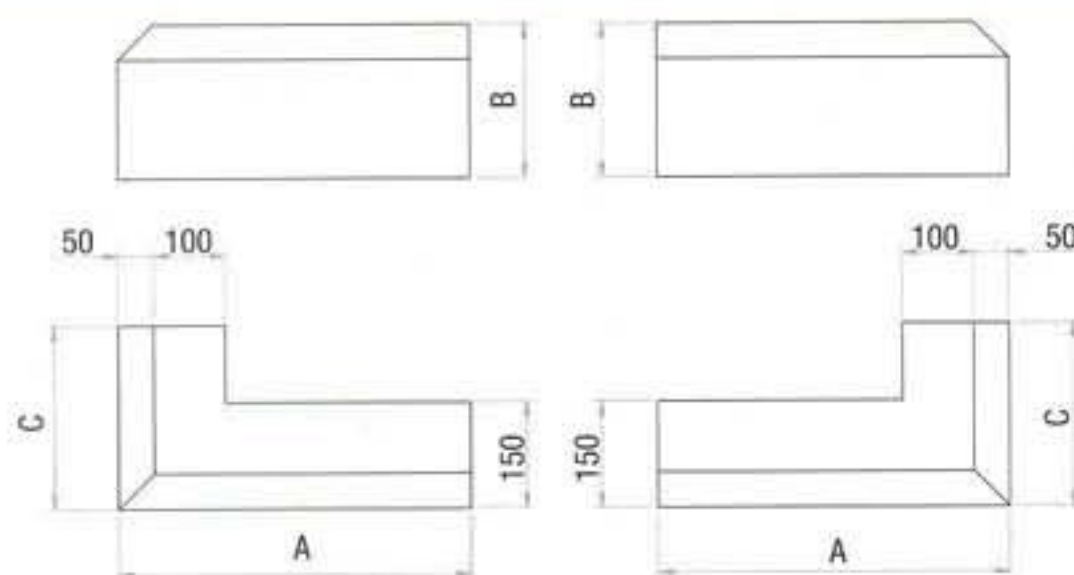

Code	A	B	C	Weight (kg)
PL6XL PL6XR	490	140	265	25
PL1XL PL1XR	490	215	265	39
PLXL PLXR	494	219	269	40
PL3XL PL3XR	490	290	340	60
PL4XL PL4XR	494	294	344	61
PL5XL PL5XR	644	294	344	75

PLH

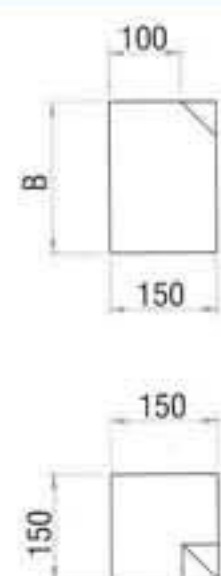

Code	B	Weight (kg)
PL6H	140	7
PL1H	215	10
PLH*	219	10
PL3H	290	14
PL4H	294	14

* denotes product in The Homestyle Range

PLX45

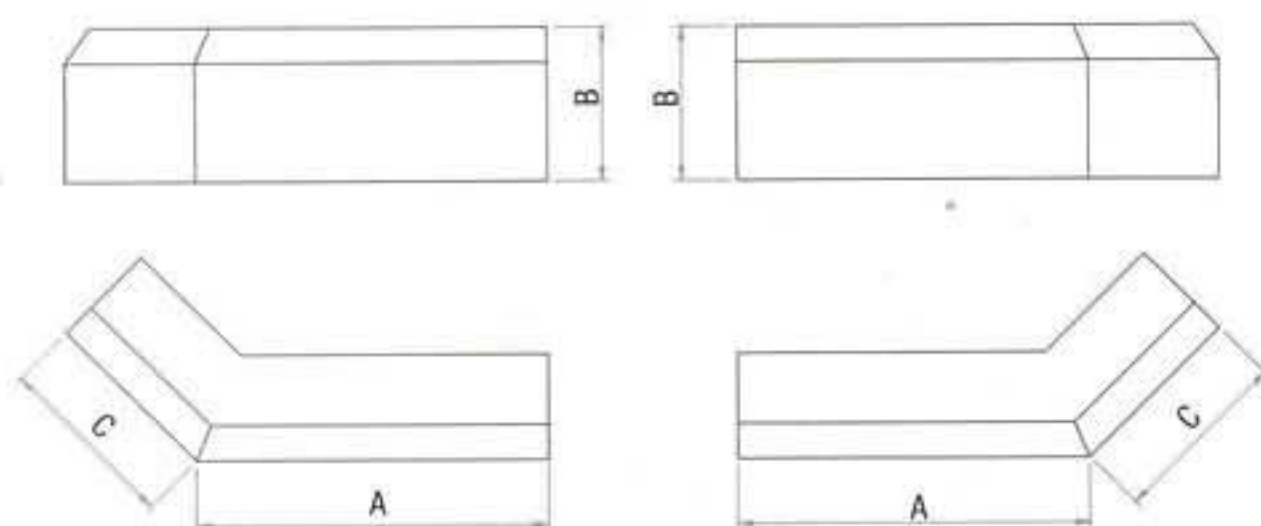

Code	A	B	C	Weight (kg)
PL6XL45 PL6XR45	461	140	236	24
PL1XL45 PL1XR45	461	215	236	39
PL2XL45 PL2XR45	465	219	240	41
PL3XL45 PL3XR45	461	290	236	54
PL4XL45 PL4XR45	465	294	240	55
PL5XL45 PL5XR45	615	294	315	76

PLH45

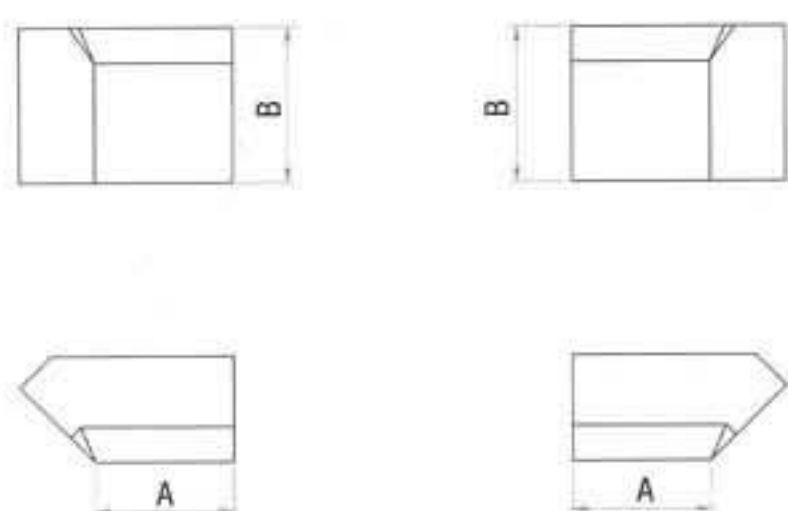

Code	A	B	Weight (kg)
PL6HL45 PL6HR45	194	140	10
PL1HL45 PL1HR45	194	215	17
PL2HL45 PL2HR45	198	219	17
PL3HL45 PL3HR45	194	290	23
PL4HL45 PL4HR45	198	294	23
PL5HL45 PL5HR45	273	294	30

Plinth Blocks



PL

Code	A	B	Weight (kg)
PL7	440	140	18
PL8	440	215	29
PL9	444	219	30
PL10	440	290	40
PL11	444	294	41
PL12	594	294	54

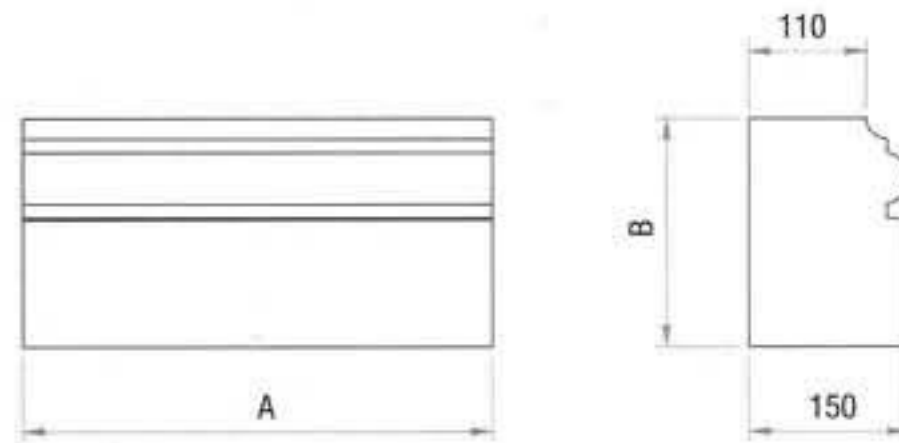

PLX

Code	A	B	C	Weight (kg)
PL7XL	490	140	265	25
PL8XL	490	215	265	39
PL9XL	494	219	269	40
PL10XL	490	290	340	60
PL11XL	494	294	344	61
PL12XL	644	294	344	75

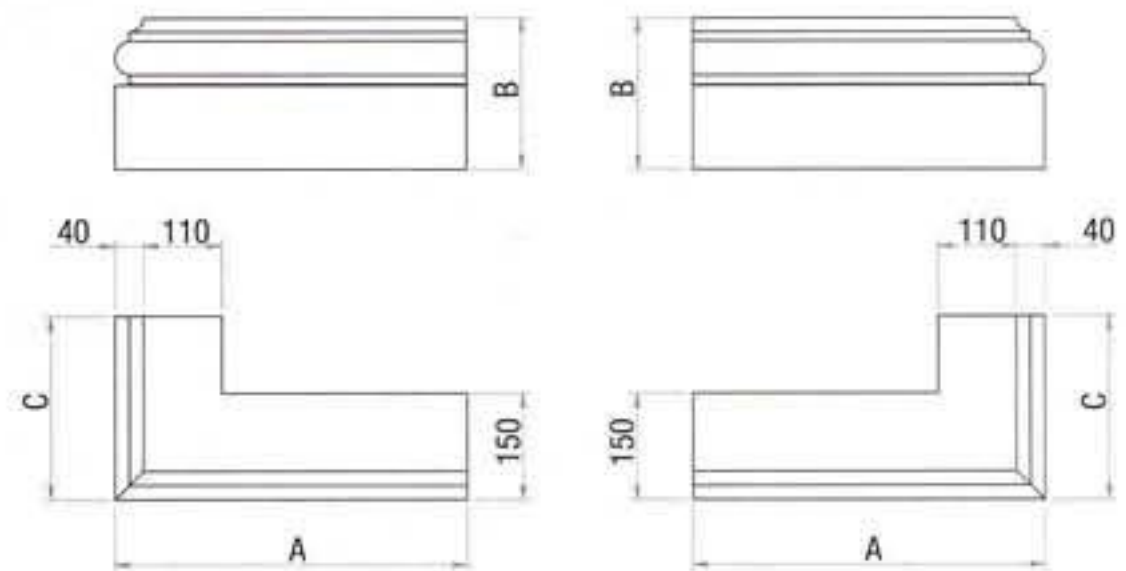

PLH

Code	A	Weight (kg)
PL7H	140	7
PL8H	215	10
PL9H	219	10
PL10H	290	14
PL11H	294	14

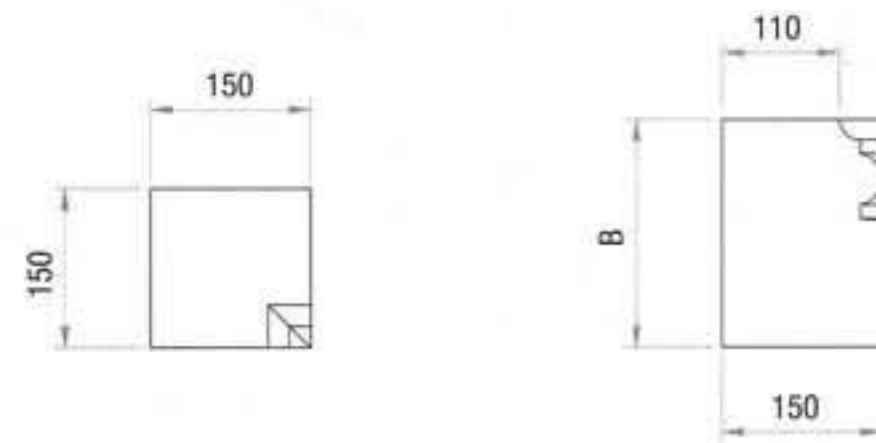

PLX45

Code	A	B	C	Weight (kg)
PL7XL45	461	140	236	24
PL8XL45	461	215	236	39
PL9XL45	465	219	240	41
PL10XL45	461	290	236	54
PL11XL45	465	294	240	55
PL12XL45	615	294	315	76

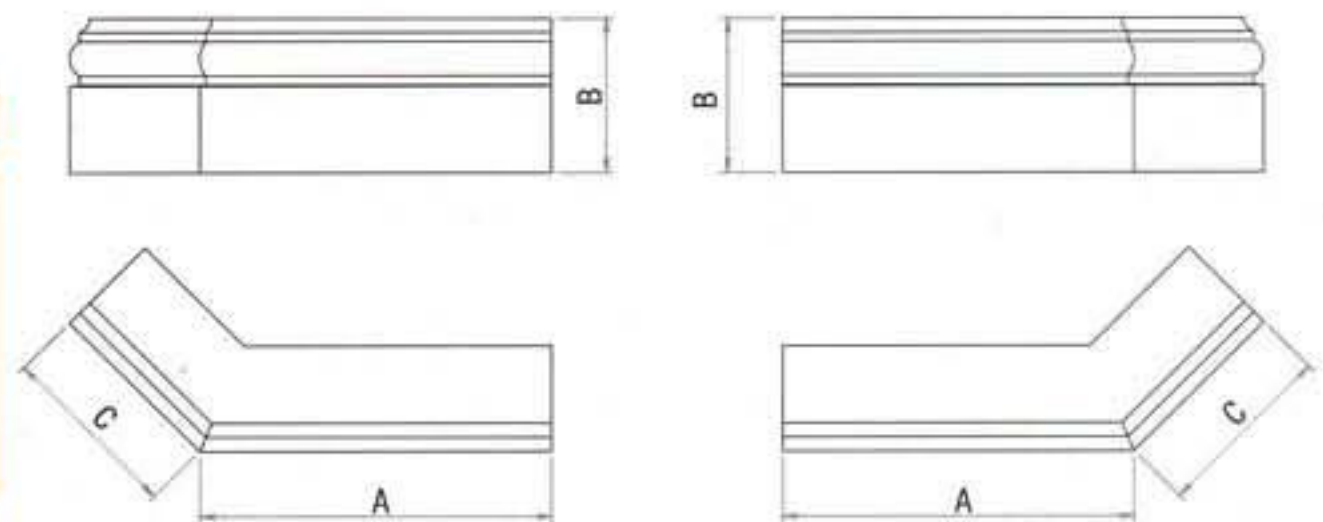

PLH45

Code	A	B	Weight (kg)
PL7HL45	194	140	10
PL8HL45	194	215	17
PL9HL45	198	219	17
PL10HL45	194	290	23
PL11HL45	198	294	23
PL12HL45	273	294	30

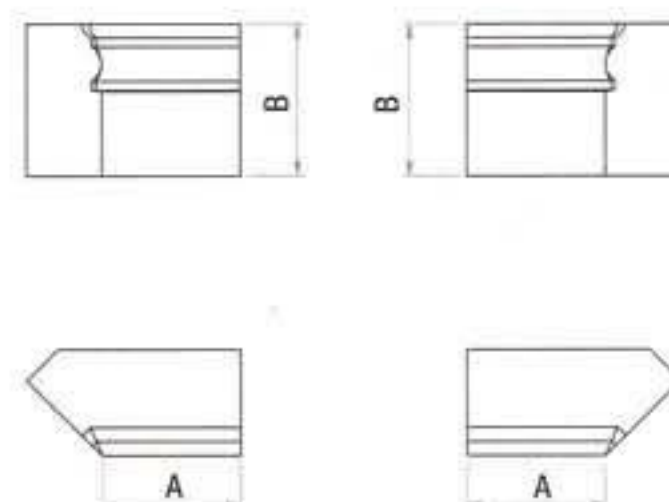

Plinth Blocks



PL

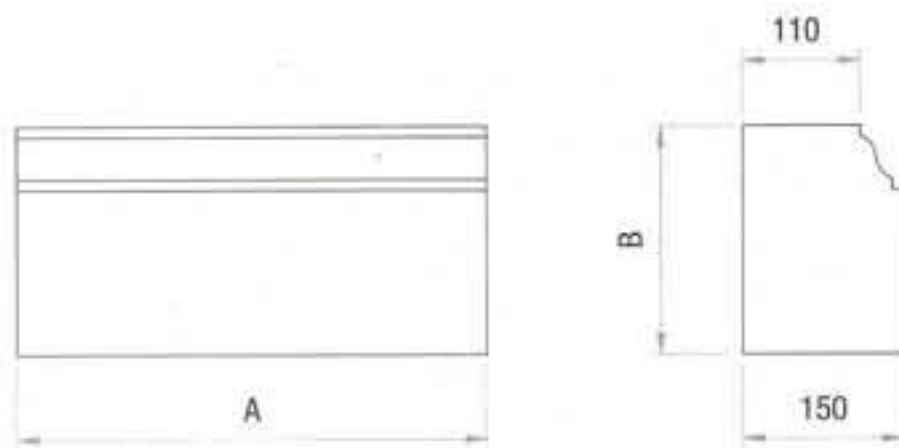

Code	A	B	Weight (kg)
PL13	440	140	18
PL14	440	215	29
PL15	444	219	30
PL16	440	290	40
PL17	444	294	41
PL18	594	294	54

PLX

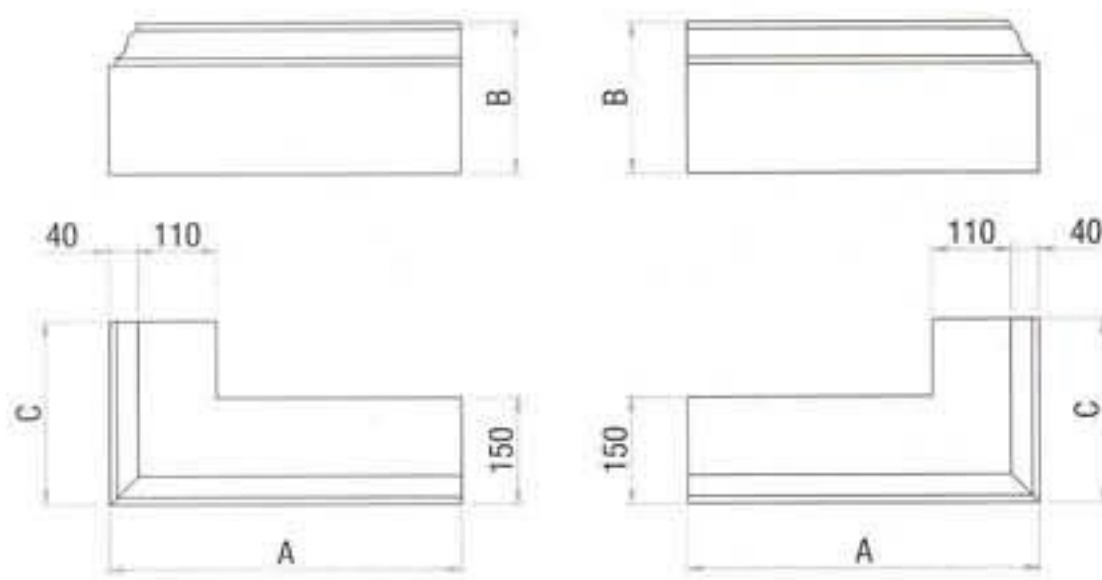

Code	A	B	C	Weight (kg)
PL13XL	490	140	265	25
PL14XL	490	215	265	39
PL15XL	494	219	269	40
PL16XL	490	290	340	60
PL17XL	494	294	344	61
PL18XL	644	294	344	75

PLH

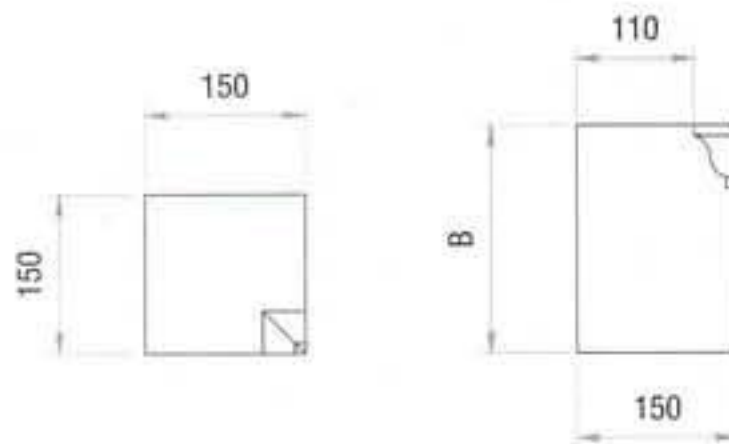

Code	B	Weight (kg)
PL13H	140	7
PL14H	215	10
PL15H	219	10
PL16H	290	14
PL17H	294	14

PLX45

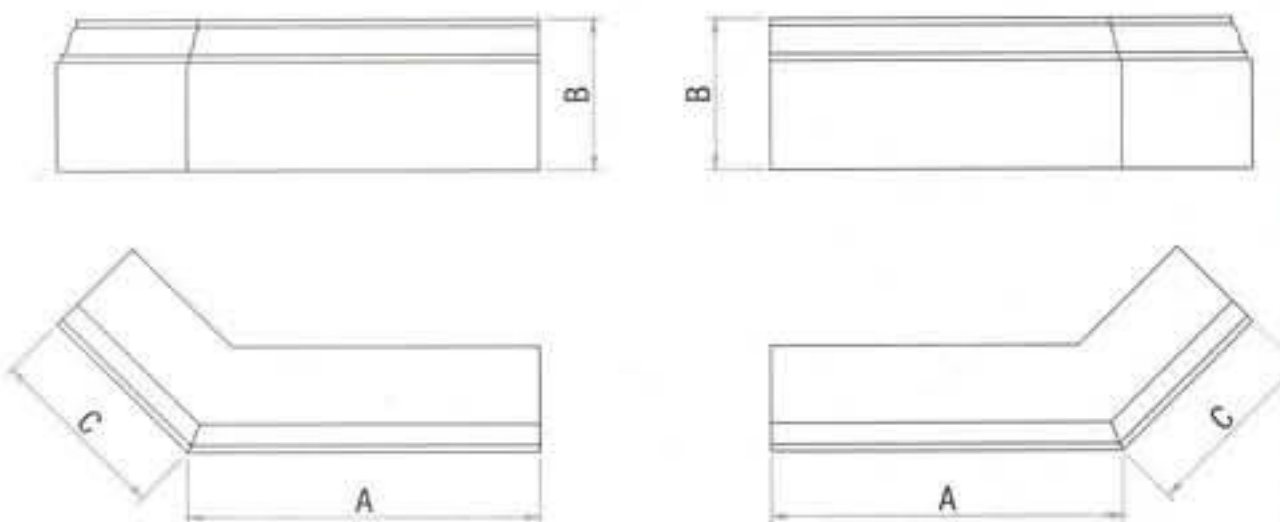

Code	A	B	C	Weight (kg)
PL13XL45	461	140	236	24
PL14XL45	461	215	236	39
PL15XL45	465	219	240	41
PL16XL45	461	290	236	54
PL17XL45	465	294	240	55
PL18XL45	615	294	315	76

PLH45

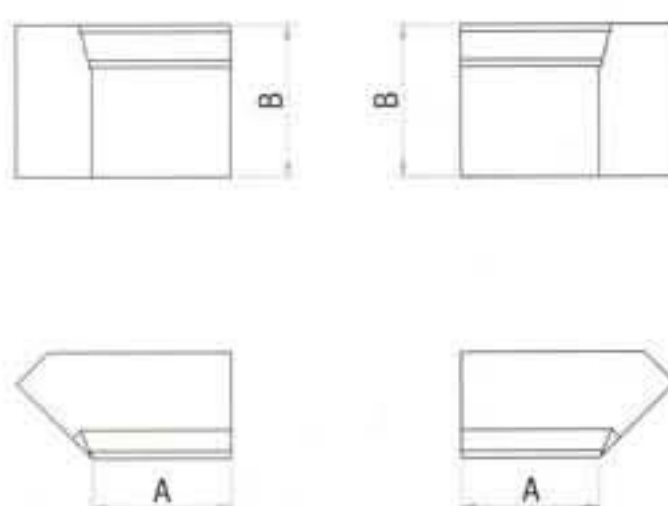

Code	A	B	Weight (kg)
PL13HL45	194	140	10
PL14HL45	194	215	17
PL15HL45	198	219	17
PL16HL45	194	290	23
PL17HL45	198	294	23
PL18HL45	273	294	30

Plinth Blocks



PL

Code	A	B	Weight (kg)
PL19	440	140	18
PL20	440	215	29
PL21	444	219	30
PL22	440	290	40
PL23	444	294	41
PL24	594	294	54

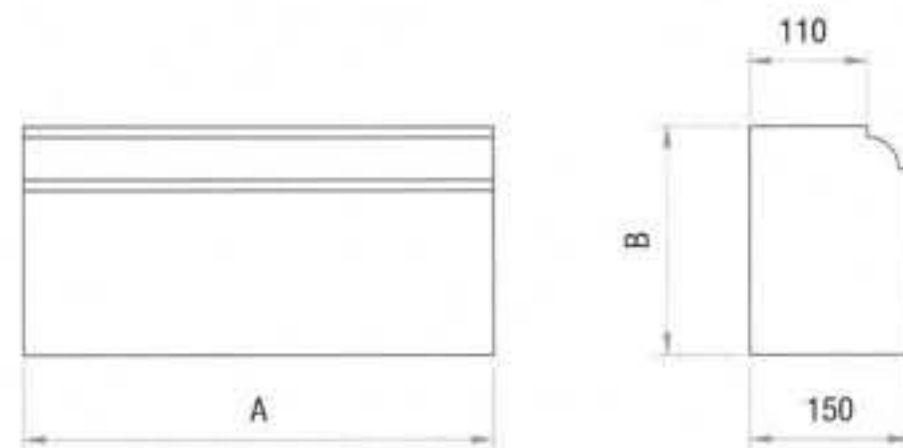

PLX

Code	A	B	C	Weight (kg)
PL19XL PL19XR	490	140	265	25
PB20XL PL20XR	490	215	265	39
PB21XL PL21XR	494	219	269	40
PB22XL PL22XR	490	290	340	60
PB23XL PL23XR	494	294	344	61
PB24XL PL24XR	644	294	344	75

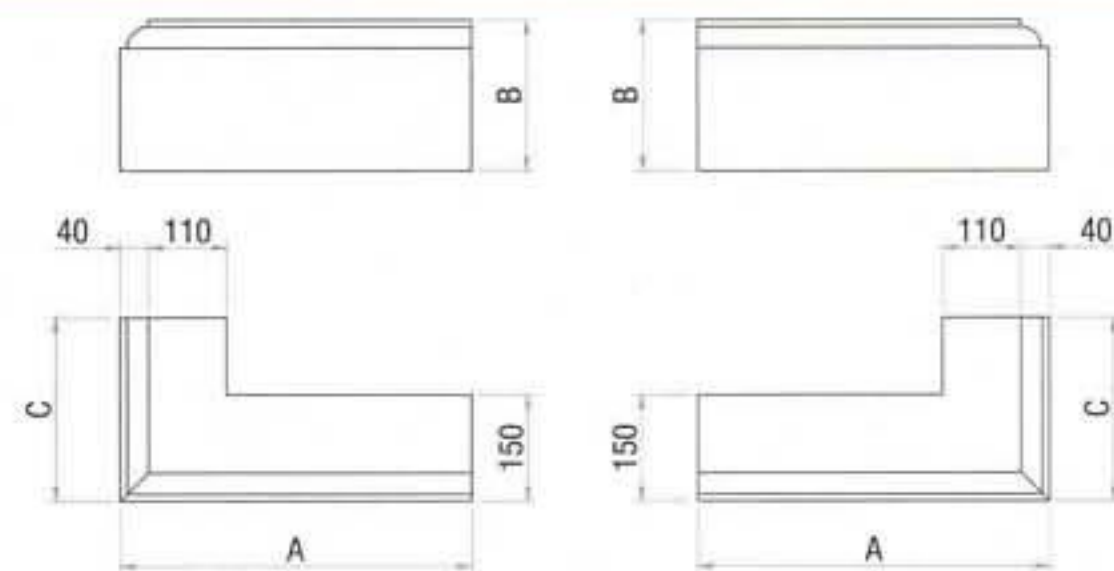

PLH

Code	B	Weight (kg)
PL19H	140	7
PL20H	215	10
PL21H	219	10
PL22H	290	14
PL23H	294	14

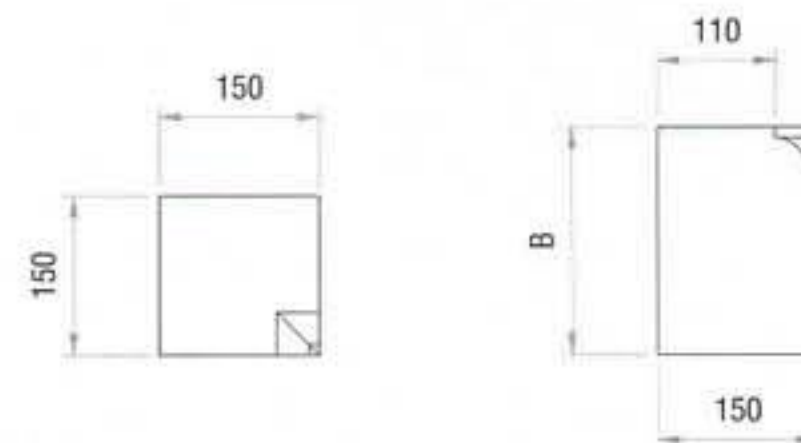

PLX45

Code	A	B	C	Weight (kg)
PL19XL45 PL19XR45	461	140	236	24
PL20XL45 PL20XR45	461	215	236	39
PL21XL45 PL21XR45	465	219	240	41
PL22XL45 PL22XR45	461	290	236	54
PL23XL45 PL23XR45	465	294	240	55
PL24XL45 PL24XR45	615	294	315	76

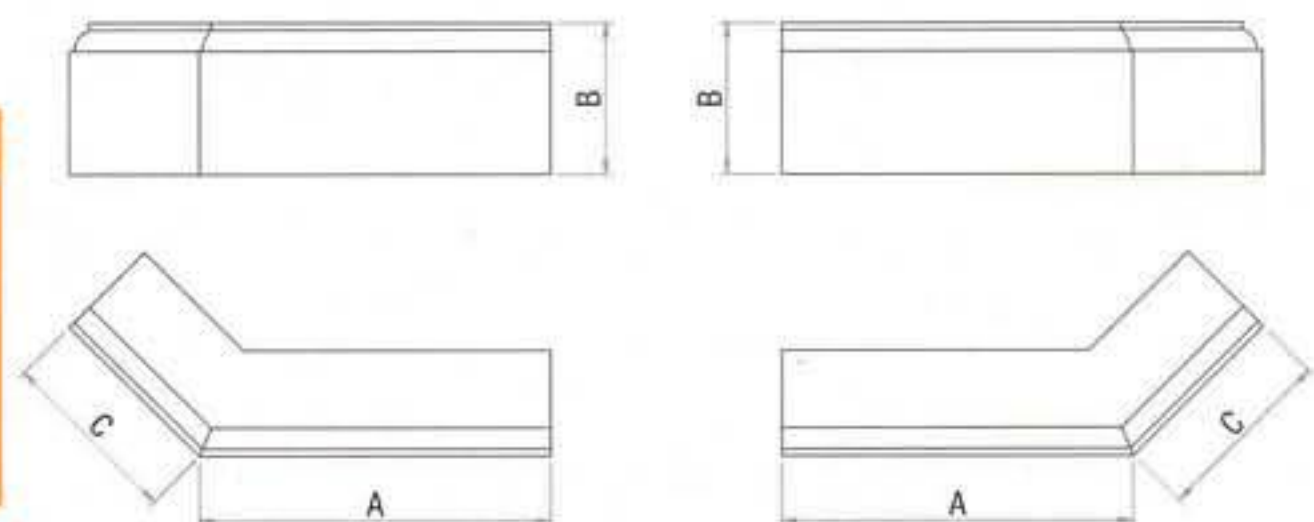

PLH45

Code	A	B	Weight (kg)
PL19HL45 PL19HR45	194	140	10
PL20HL45 PL20HR45	194	215	17
PL21HL45 PL21HR45	198	219	17
PL22HL45 PL22HR45	194	290	23
PL23HL45 PL23HR45	198	294	23
PL24HL45 PL24HR45	273	294	30

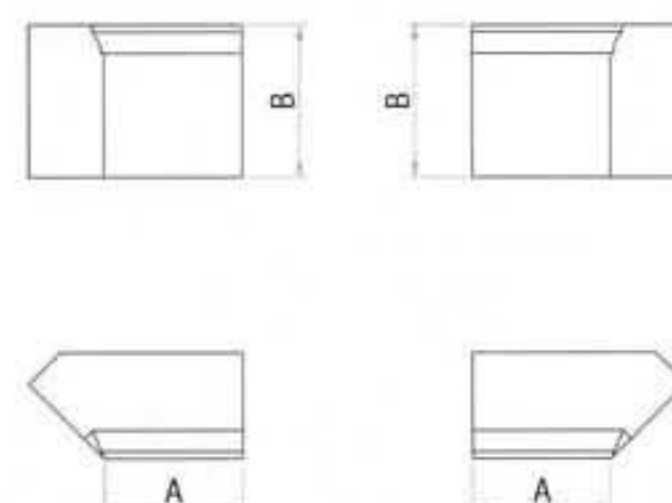

Plinth Blocks



PL

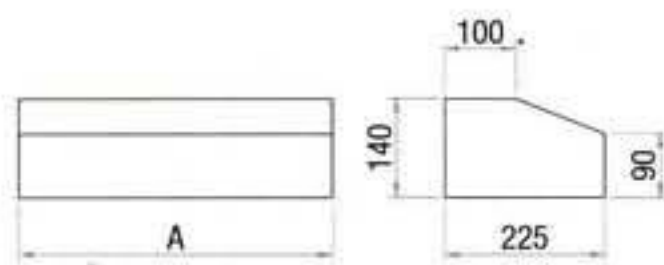

Code	A	Weight (kg)
PL25	440	26
PL26	444	27
PL27	594	36

PLX

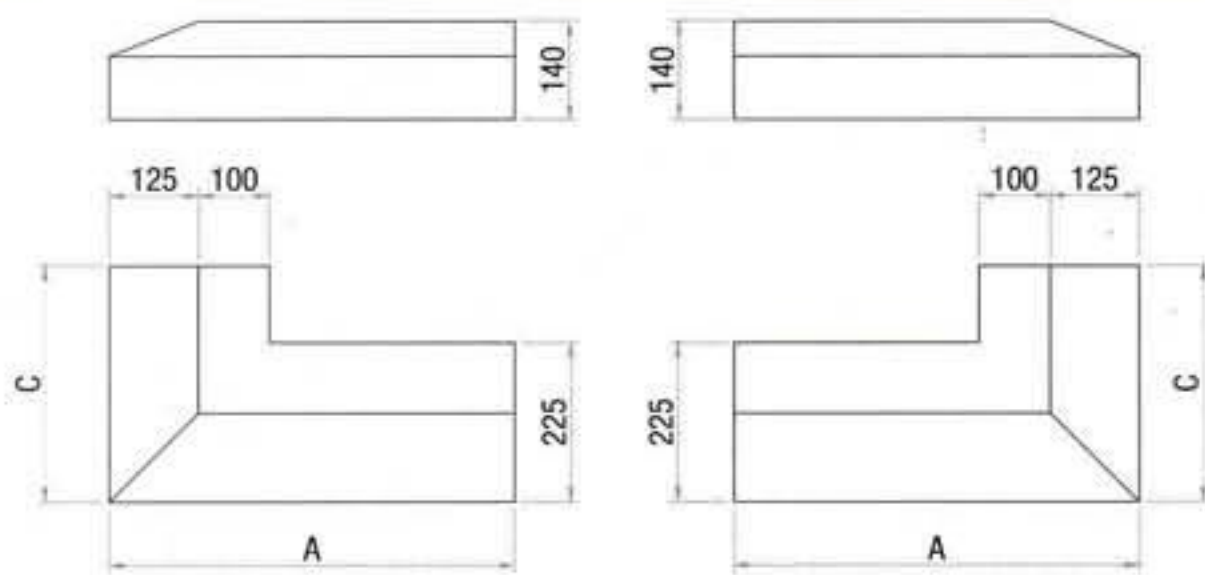

Code	A	C	Weight (kg)
PL25XL PL25XR	565	340	39
PL26XL PL26XR	569	344	40
PL27XL PL27XR	719	419	55

PLH

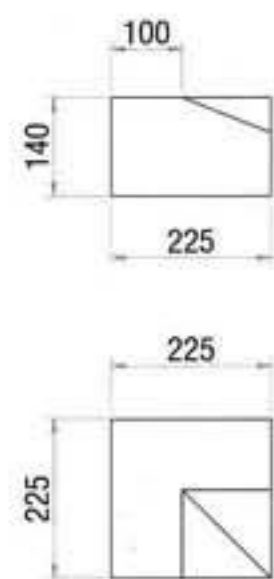

Code	Weight (kg)
PL25H	14

PLX45

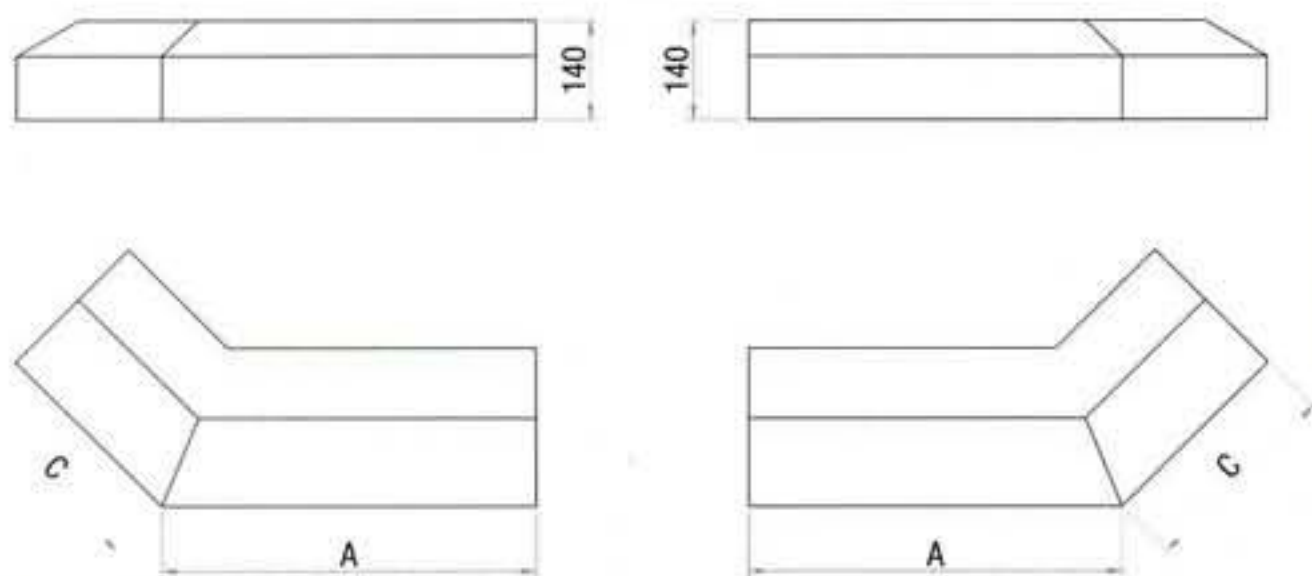

Code	A	C	Weight (kg)
PL25XL45 PL25XR45	492	267	40
PL26XL45 PL26XR45	496	271	41
PL27XL45 PL27XR45	646	346	53

PLH45

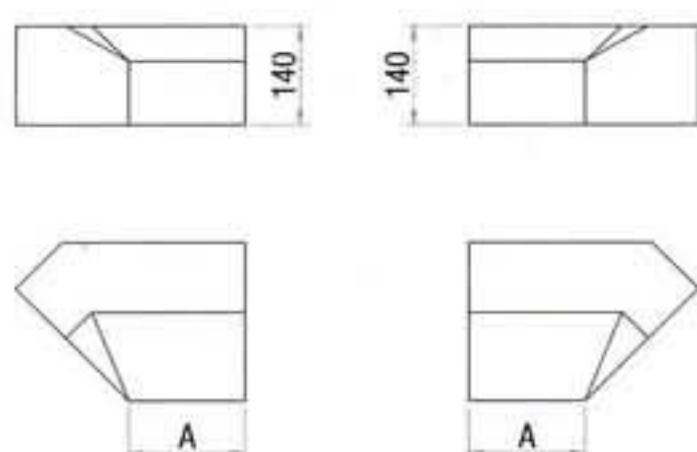

Code	A	Weight (kg)
PL25HL45 PL25HR45	163	10
PL26HL45 PL26HR45	167	10
PL27HL45 PL27HR45	242	15



Sub Plinth Blocks

PB

Code	A	B	Weight (kg)
PB6	440	140	20
PB7	440	215	30
PB30*	444	219	31
PB9	440	290	41
PB10	444	294	41
PB11	594	294	56

* denotes product in The Homestyle Range



PBX

Code	A	B	C	Weight (kg)
PB6X	490	140	265	27
PB7X	490	215	265	41
PBQ	494	219	269	42
PB9X	490	290	340	62
PB10X	494	294	344	63
PB11X	644	294	344	78

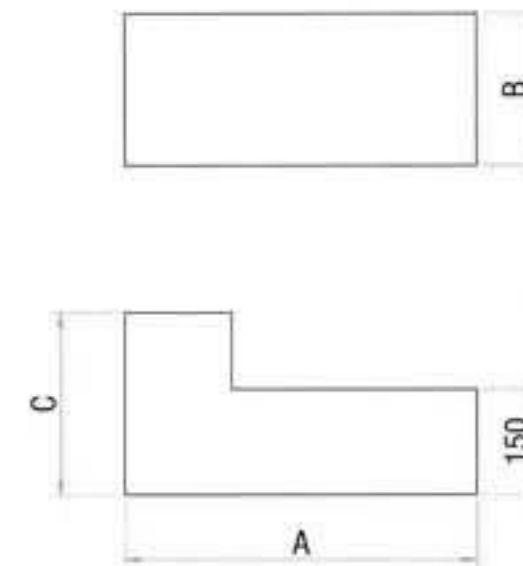

PBX45

Code	A	B	C	Weight (kg)
PB6X45	461	140	236	28
PB7X45	461	215	236	43
PB8X45	465	219	240	45
PB9X45	461	290	236	58
PB10X45	465	294	240	59
PB11X45	615	294	315	81

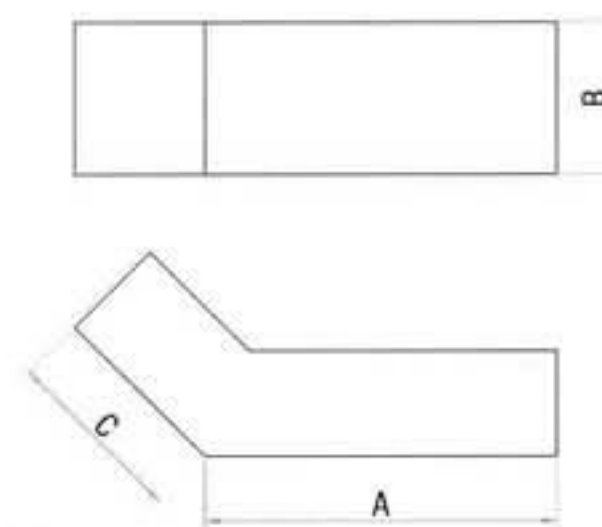

PBH45

Code	A	B	Weight (kg)
PB6H45	194	140	11
PB7H45	194	215	18
PB8H45	198	219	18
PB9H45	194	290	24
PB10H45	198	294	24
PB11H45	273	294	31

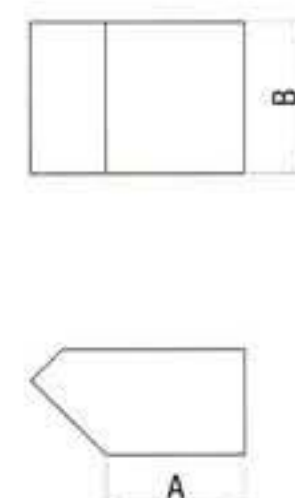

String Courses

String courses can be supplied for internal and external angles.
Weights shown are in Kg/m.



* denotes products in The Homestyle Range

SC

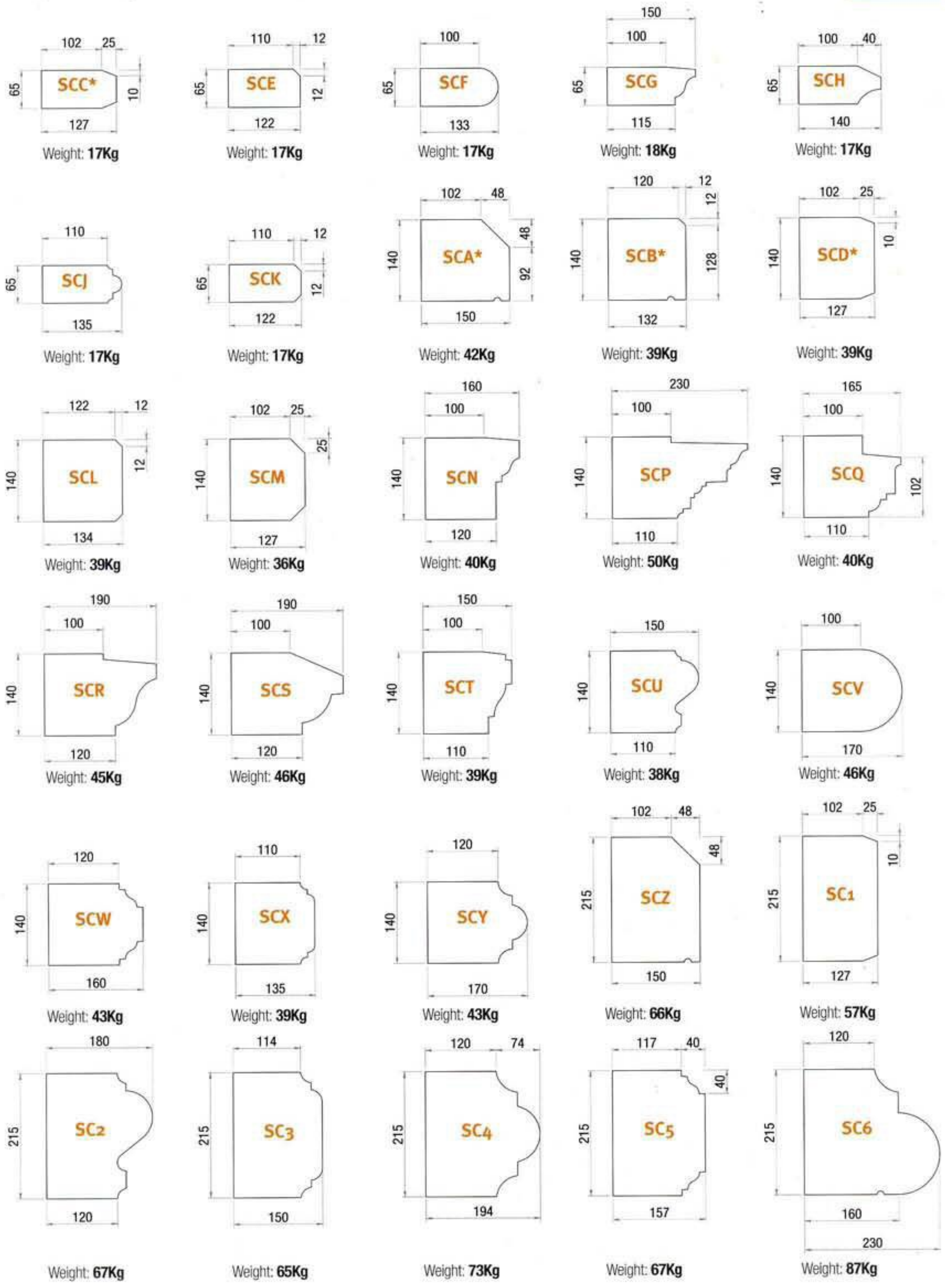



String Courses

String courses can be supplied for internal and external angles.
Weights shown are in Kg/m.

SC



Weight: 87Kg

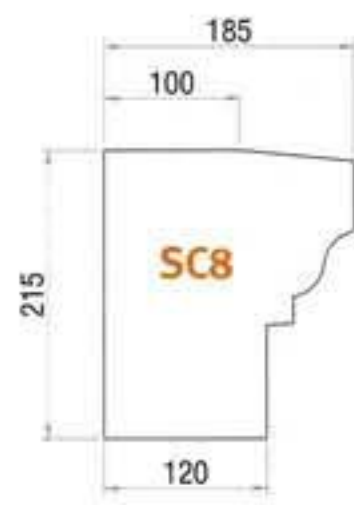

Weight: 68Kg

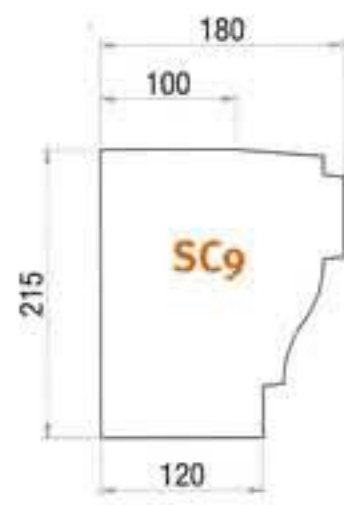

Weight: 70Kg

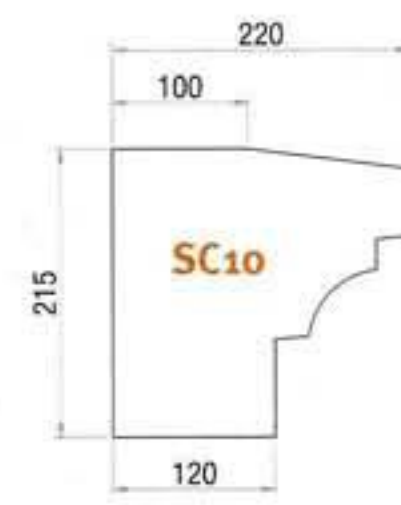

Weight: 75Kg



Weight: 70Kg



Weight: 70Kg

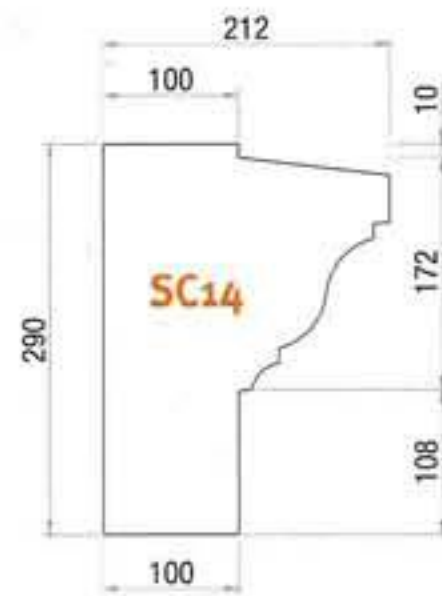

Weight: 86Kg



Weight: 46Kg



Weight: 46Kg



Weight: 61Kg



Weight: 77Kg



Weight: 41Kg

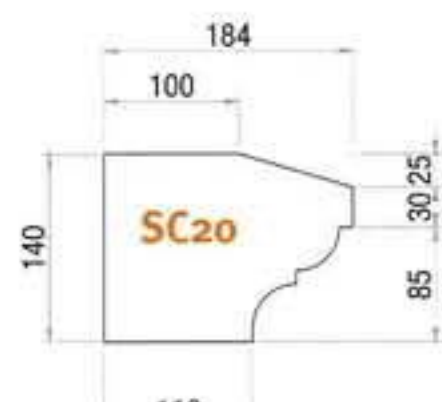

Weight: 44Kg

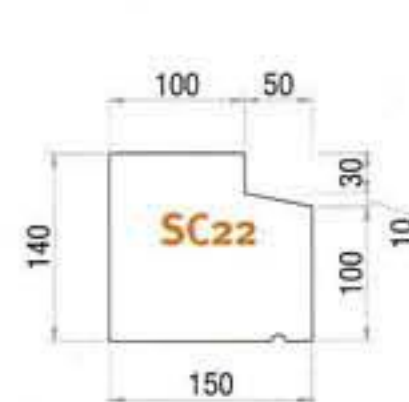

Weight: 41Kg

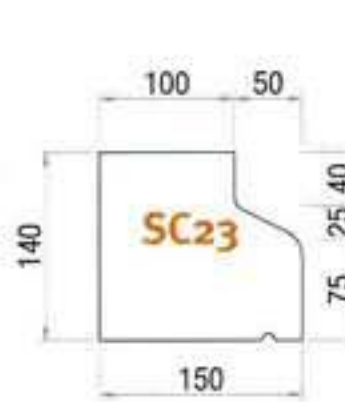

Weight: 39Kg

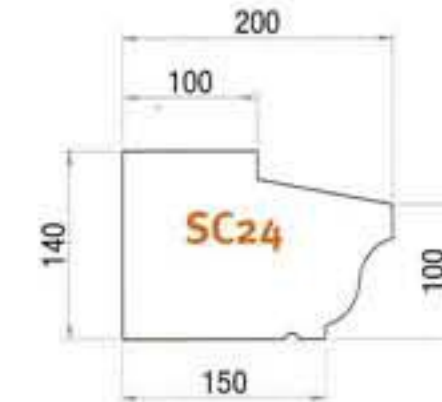

Weight: 48Kg



Weight: 61Kg

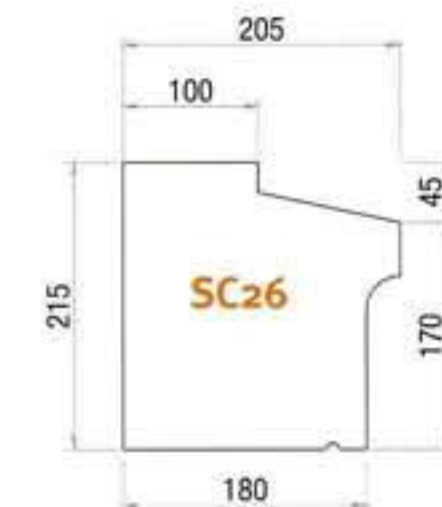

Weight: 79Kg



Weight: 16Kg

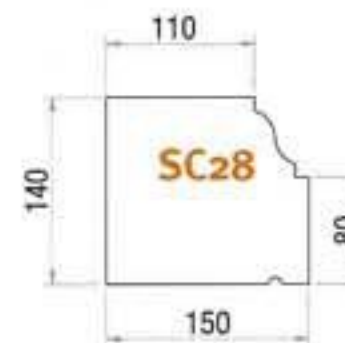

Weight: 41Kg



Weight: 65Kg



Weight: 66Kg

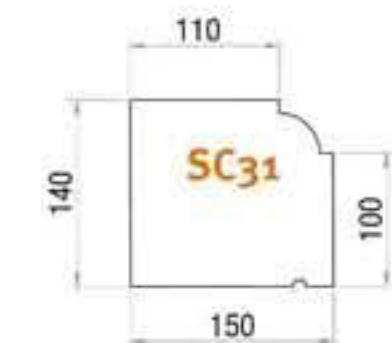

Weight: 43Kg



Weight: 65Kg

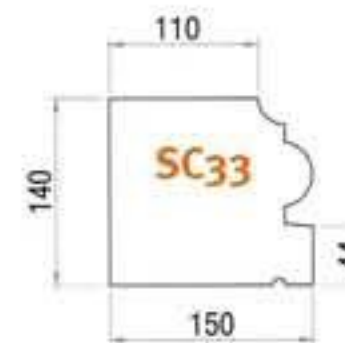

Weight: 41Kg



Weight: 68Kg

String Courses



The stones detailed on this page can be manufactured for all string course profiles. When ordering please state which profile is required (ie SC7 with LH external return would be SC7-X90L) and radius dimension 'R' for curved string courses.

Typical Detail

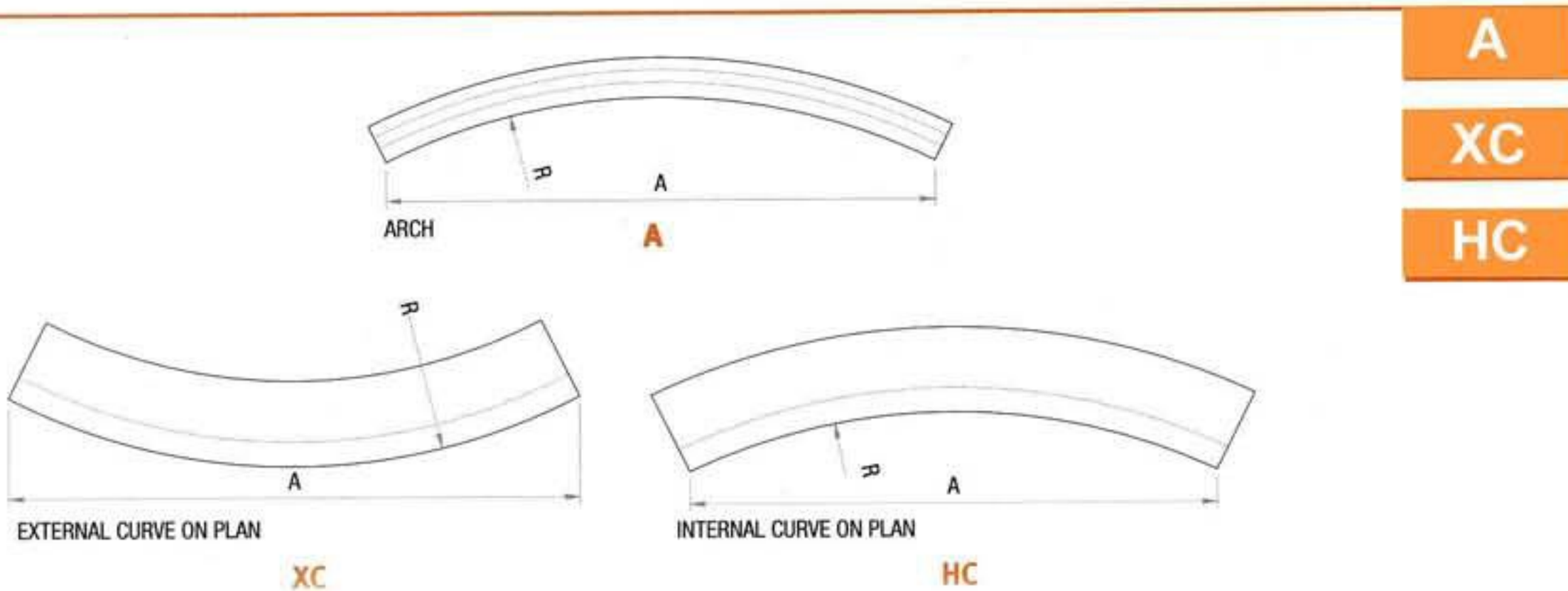
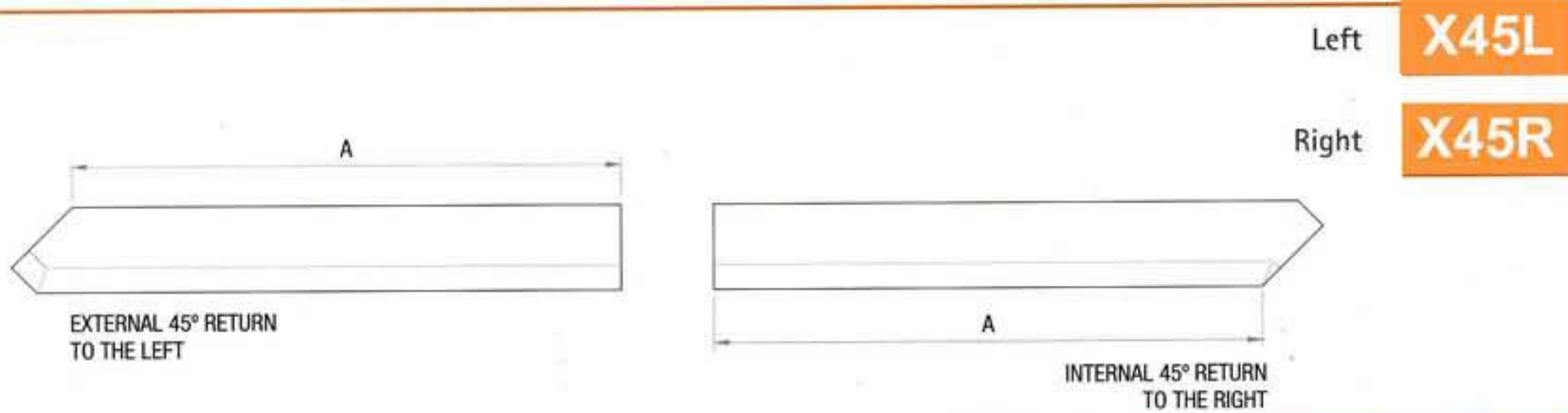
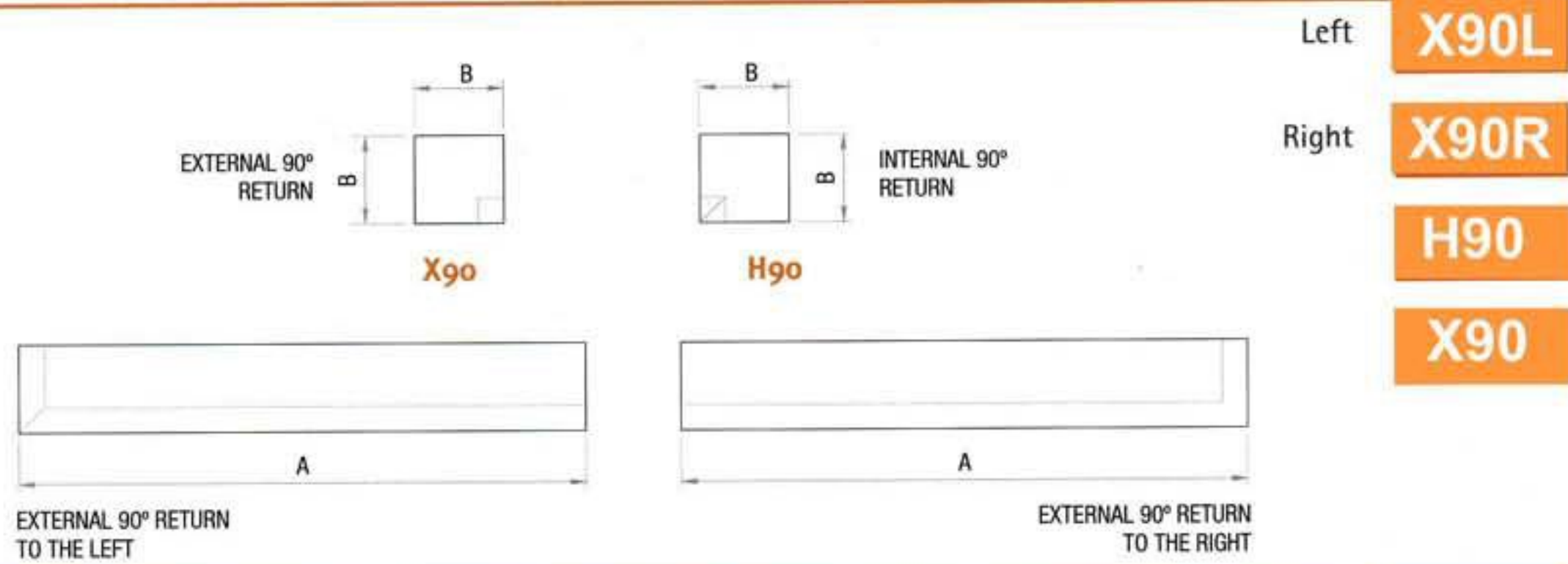
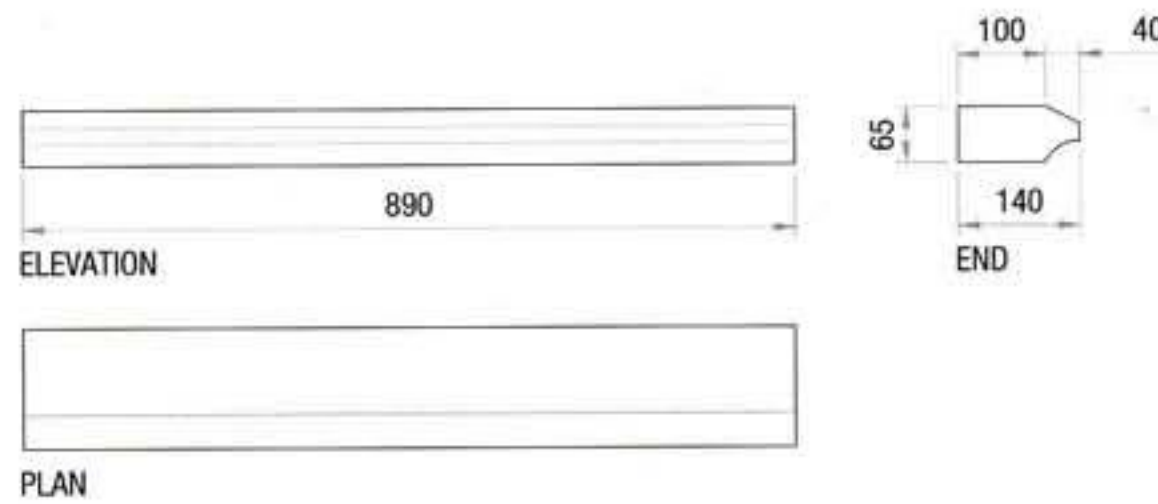



Cornices

A qualified structural engineer should detail fixing and/or restraint.
Weights shown are in Kg/m.

A Technical Data Sheet showing the recommended installation is available on request.

CE1

CE2

CE3

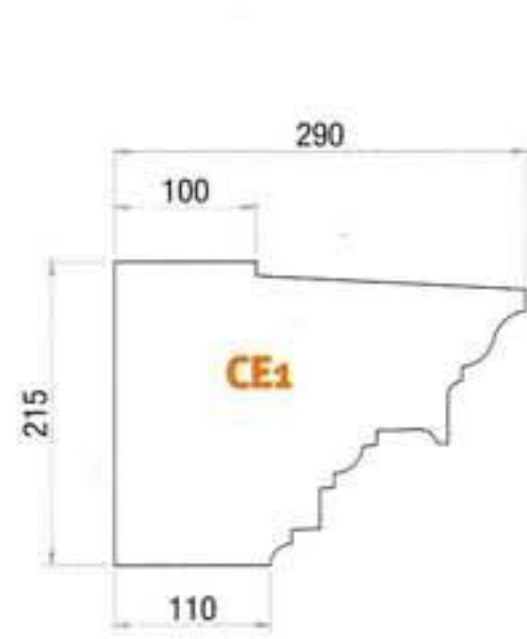

Weight: 90Kg

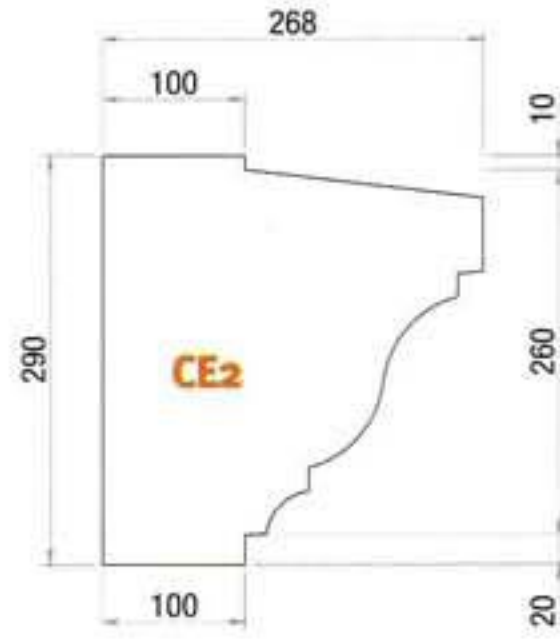

Weight: 117Kg



Weight: 142Kg

UC4

LC4

UC5

LC5

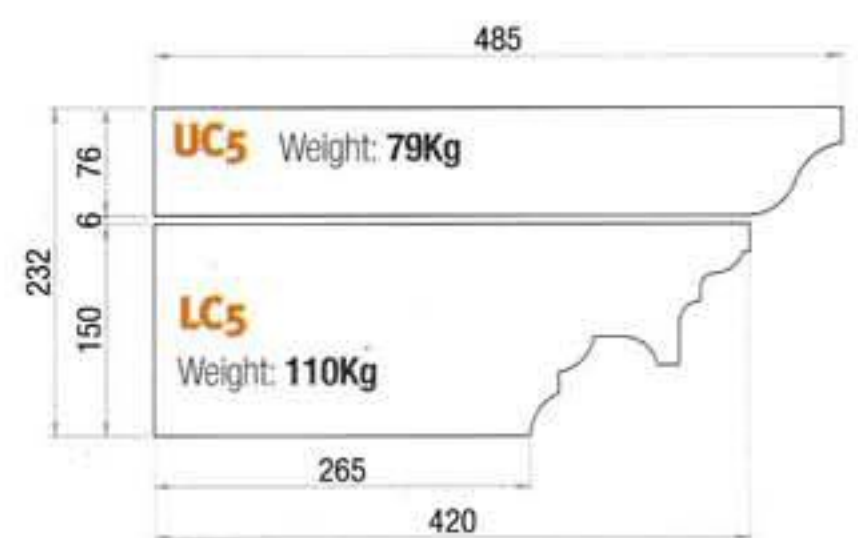
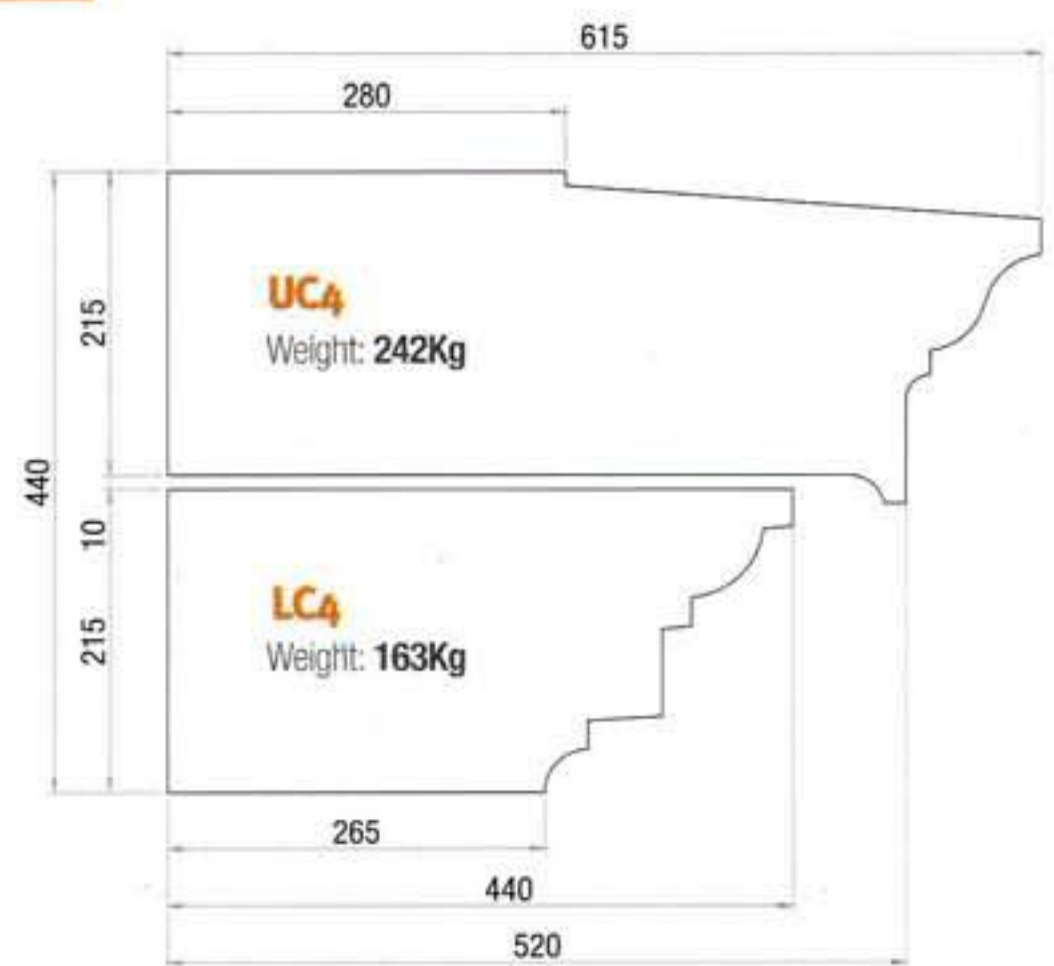

Cornices



A qualified structural engineer should detail fixing and/or restraint.
Weights shown are in Kg/m.

A Technical Data Sheet showing the recommended installation is available on request.

UC6

LC6

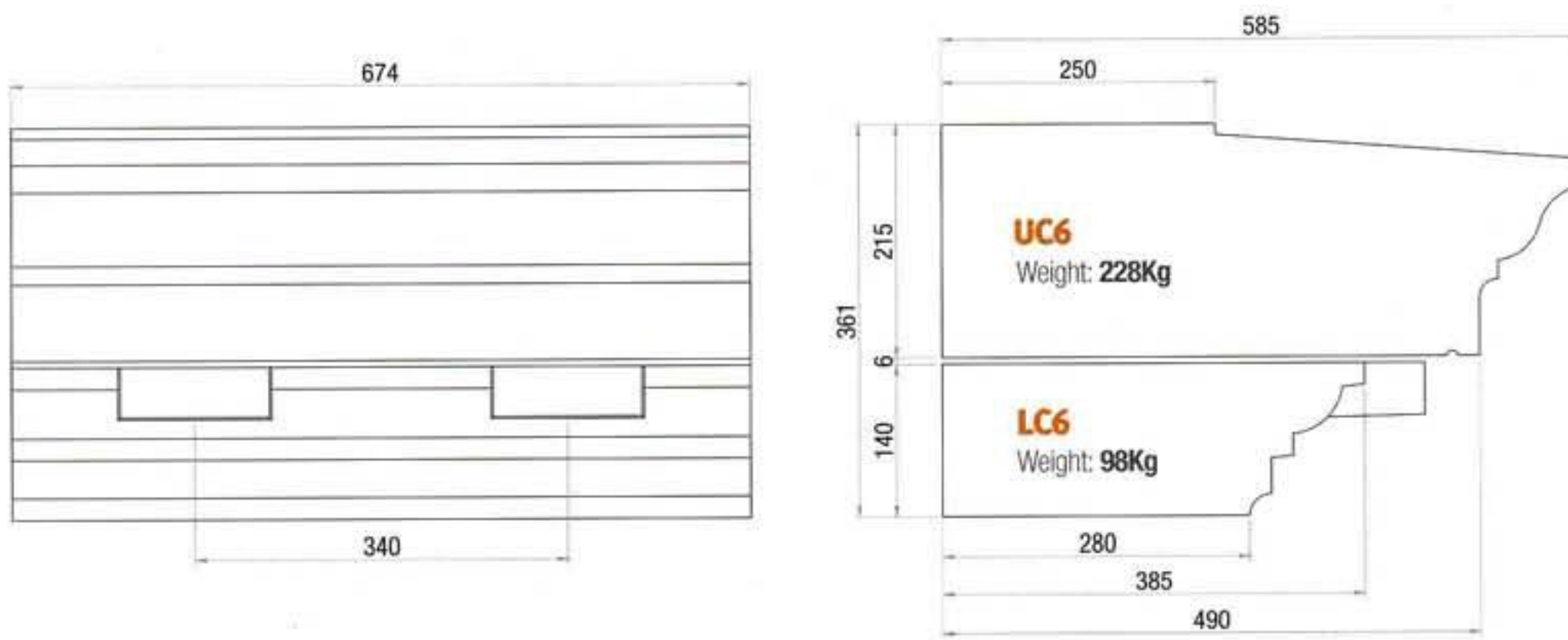

UC7

LC7

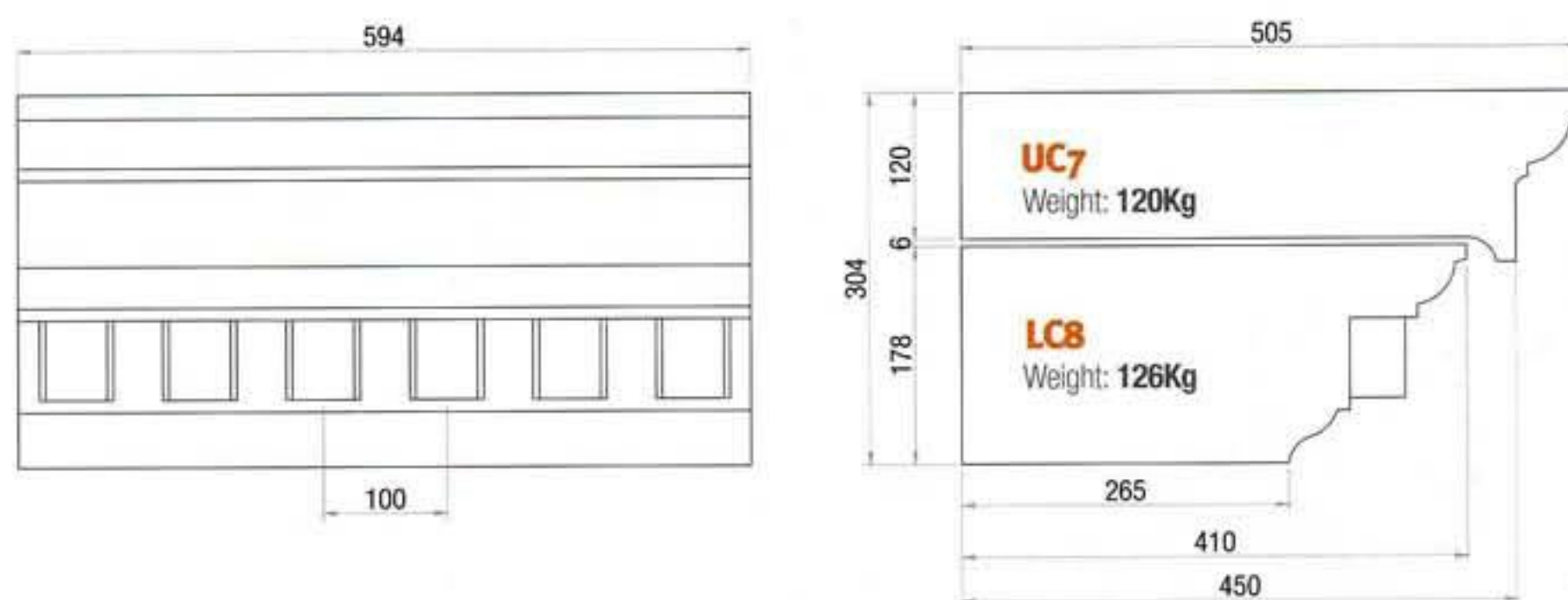

Pavilions



PN1

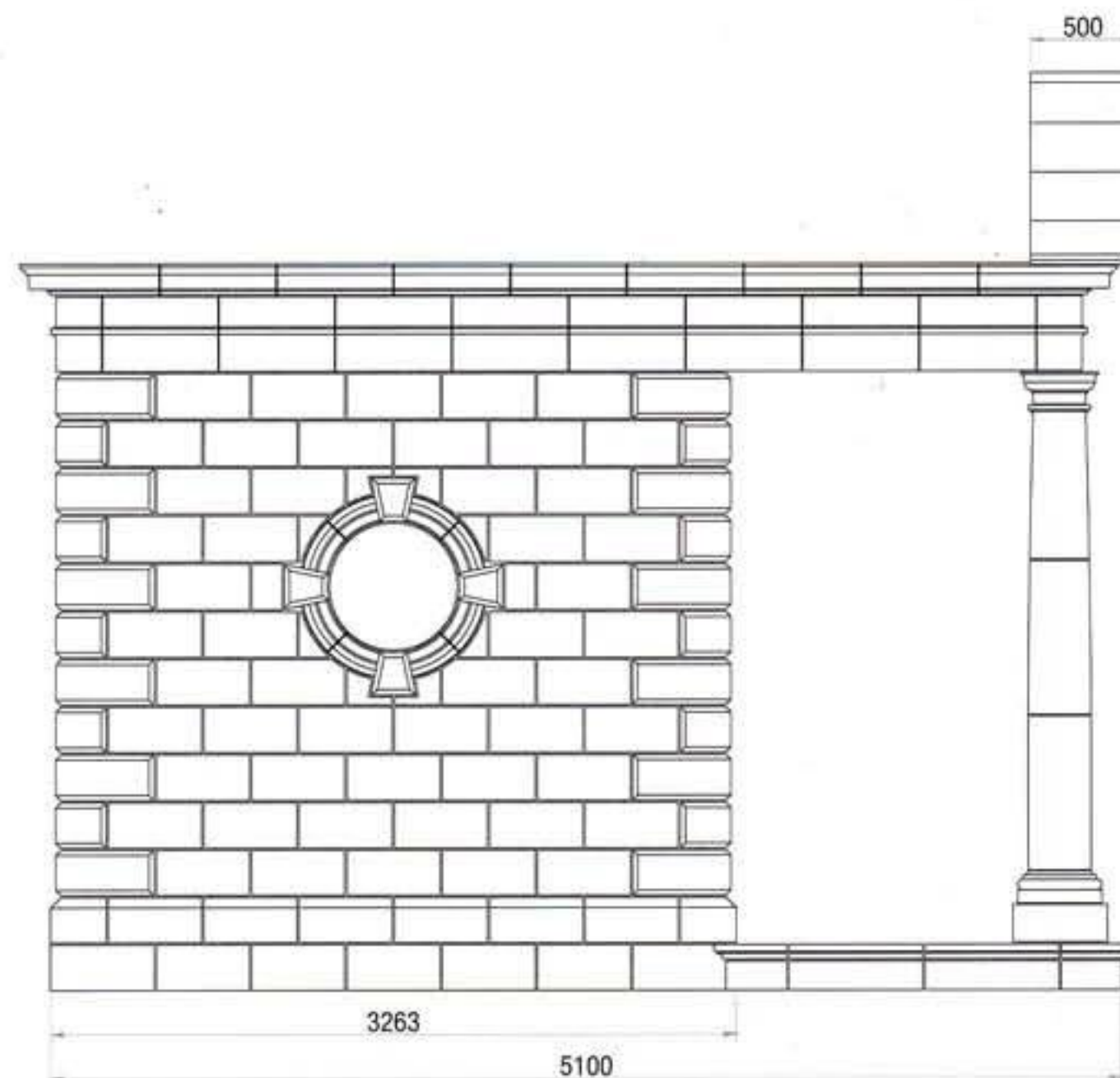
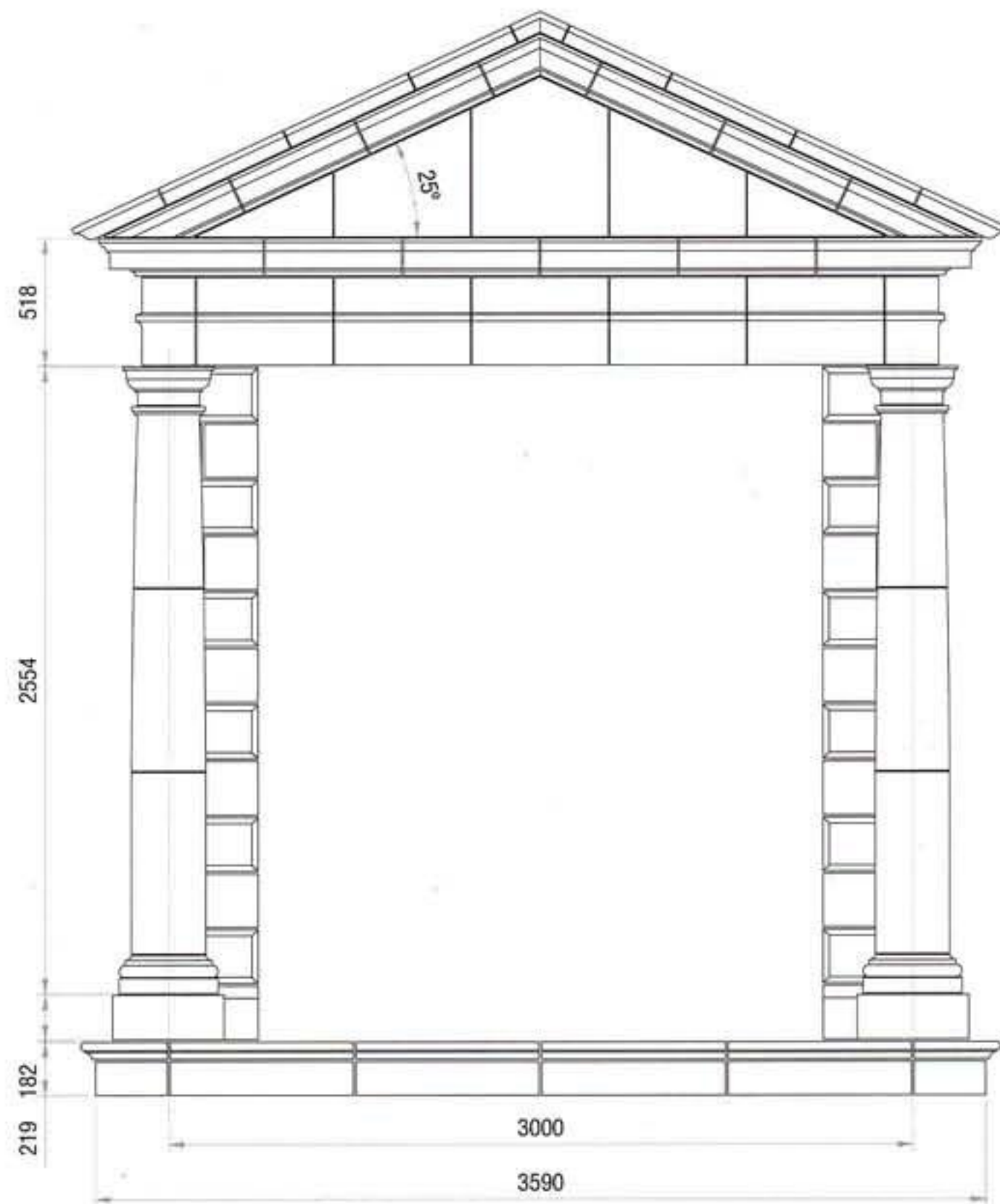



Temples

Large Classical Temple

This is available with either five or six column supports and the dome can be supplied in lead-effect GRP or GRC to match stone.

DM1

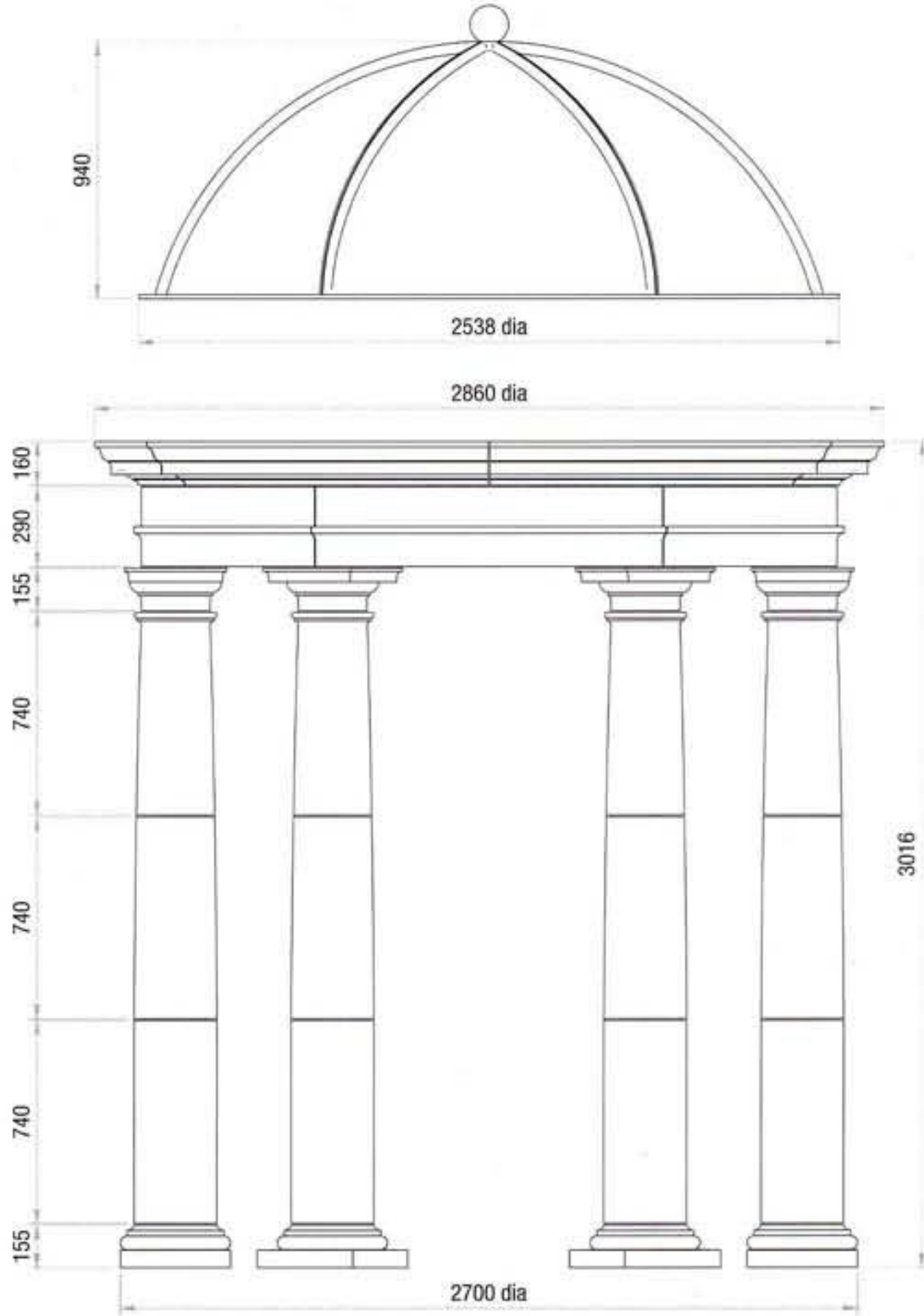

TP1

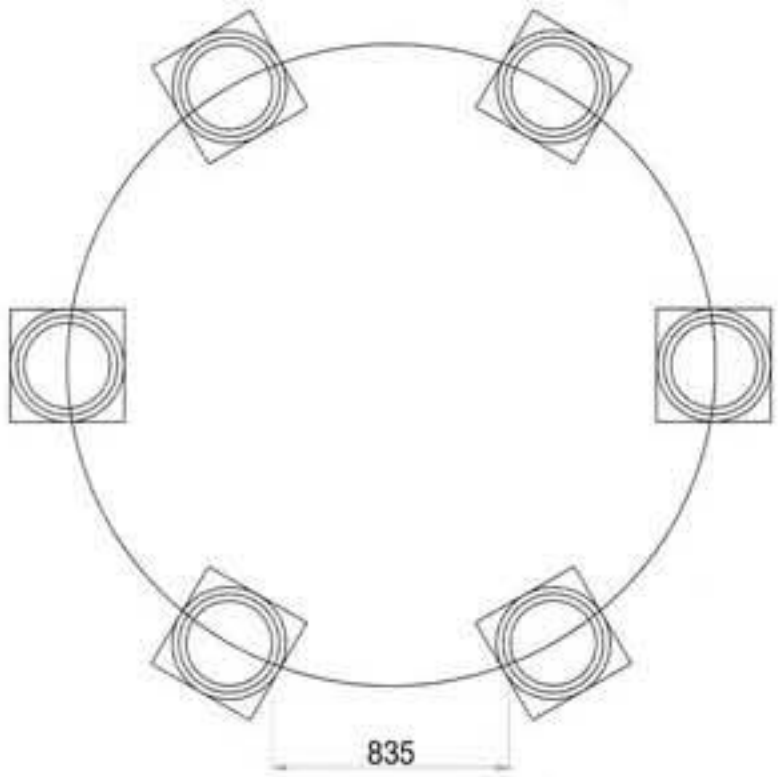

Total Weight: 3800Kg

TP4

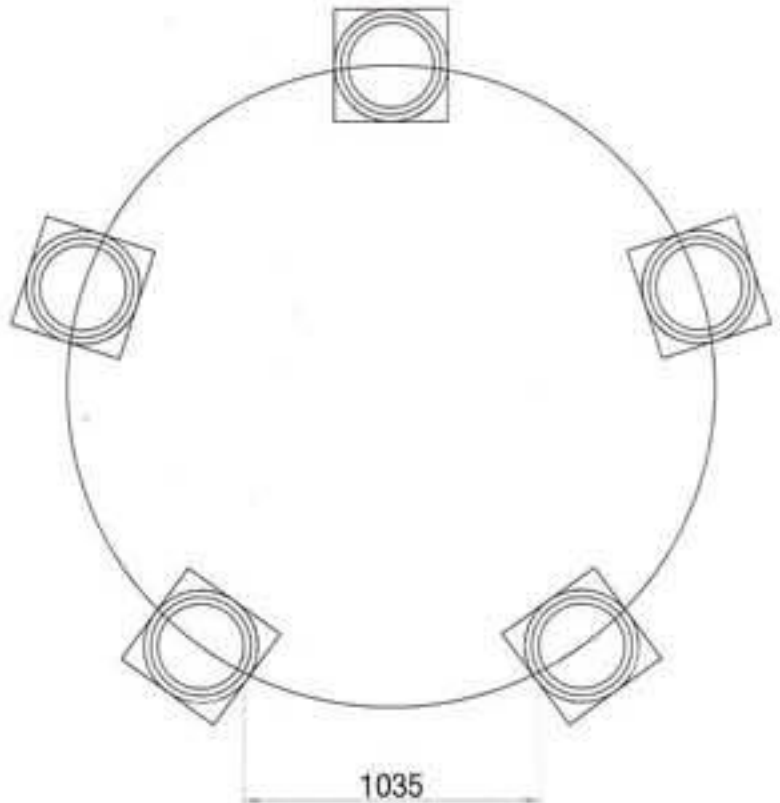

Total Weight: 3400Kg

Temples



Small Classical Temple

This is available with either five or six column supports and the dome can be supplied in lead-effect GRP or GRC to match stone.

DM2

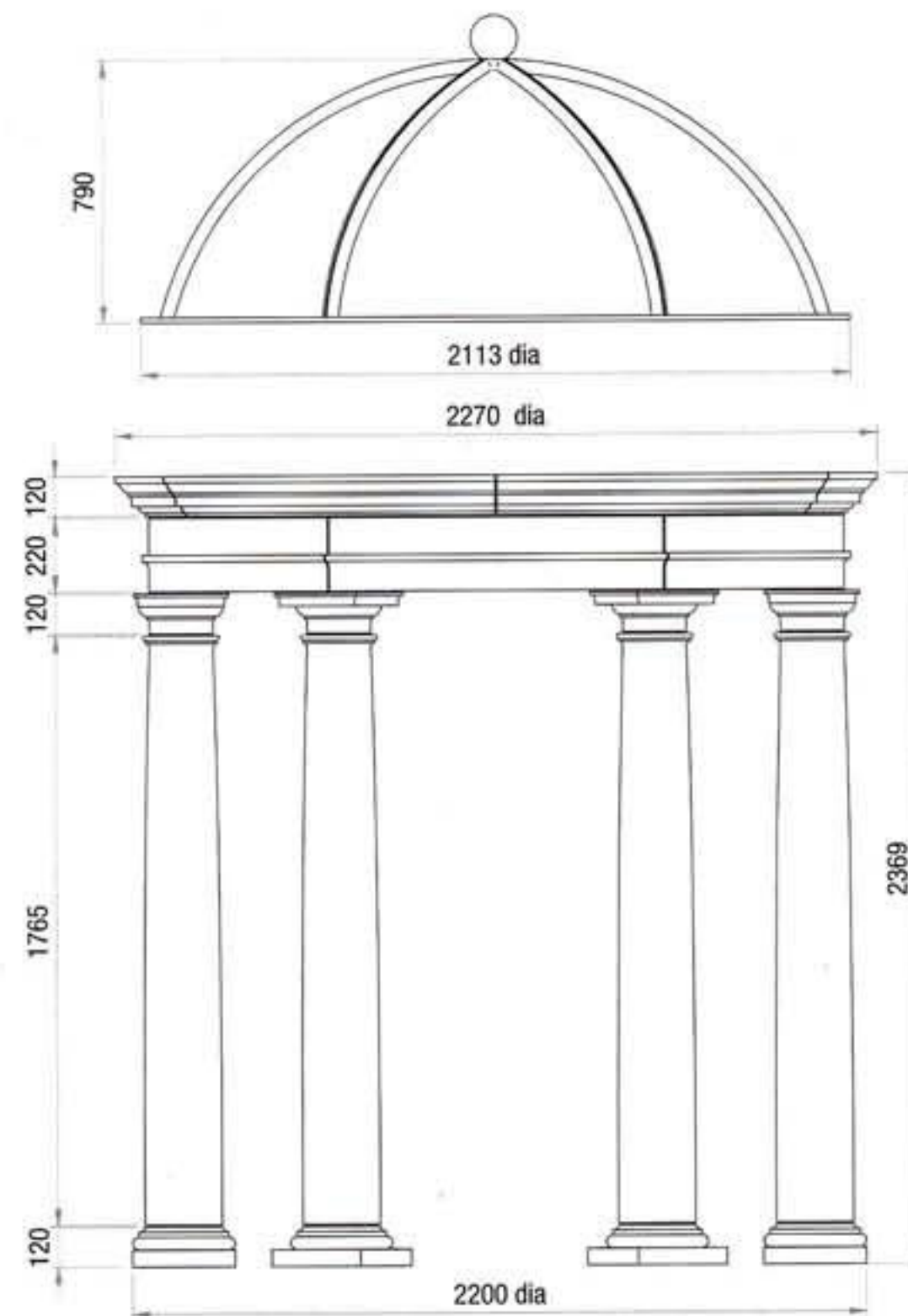

TP2

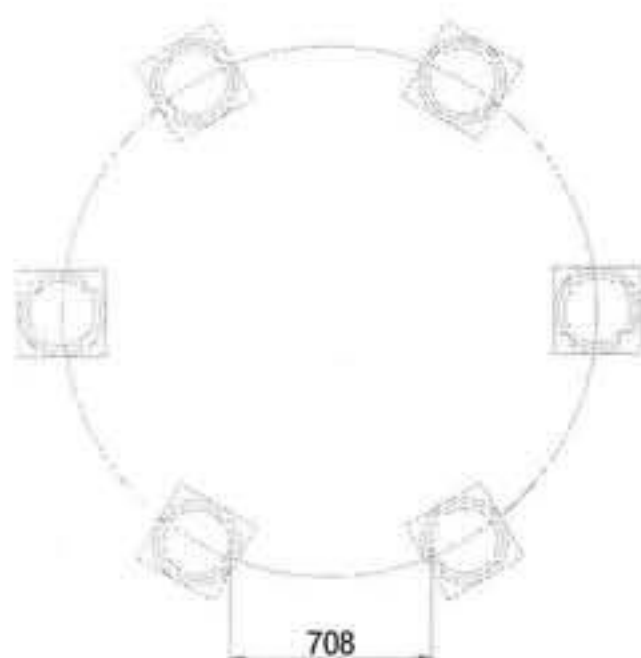

Total Weight: 1660Kg

TP5

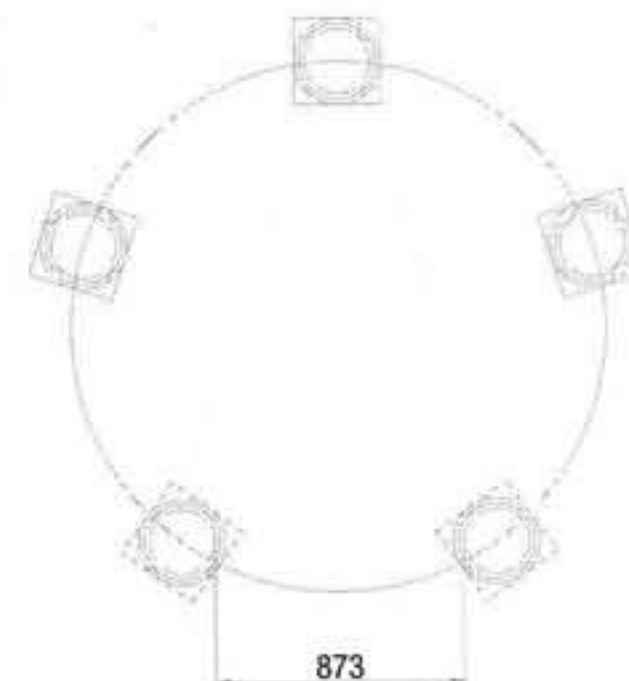

Total Weight: 1500Kg

Temples

Art Deco Temple

The dome can be supplied in lead-effect GRP or GRC to match stone.



DM2

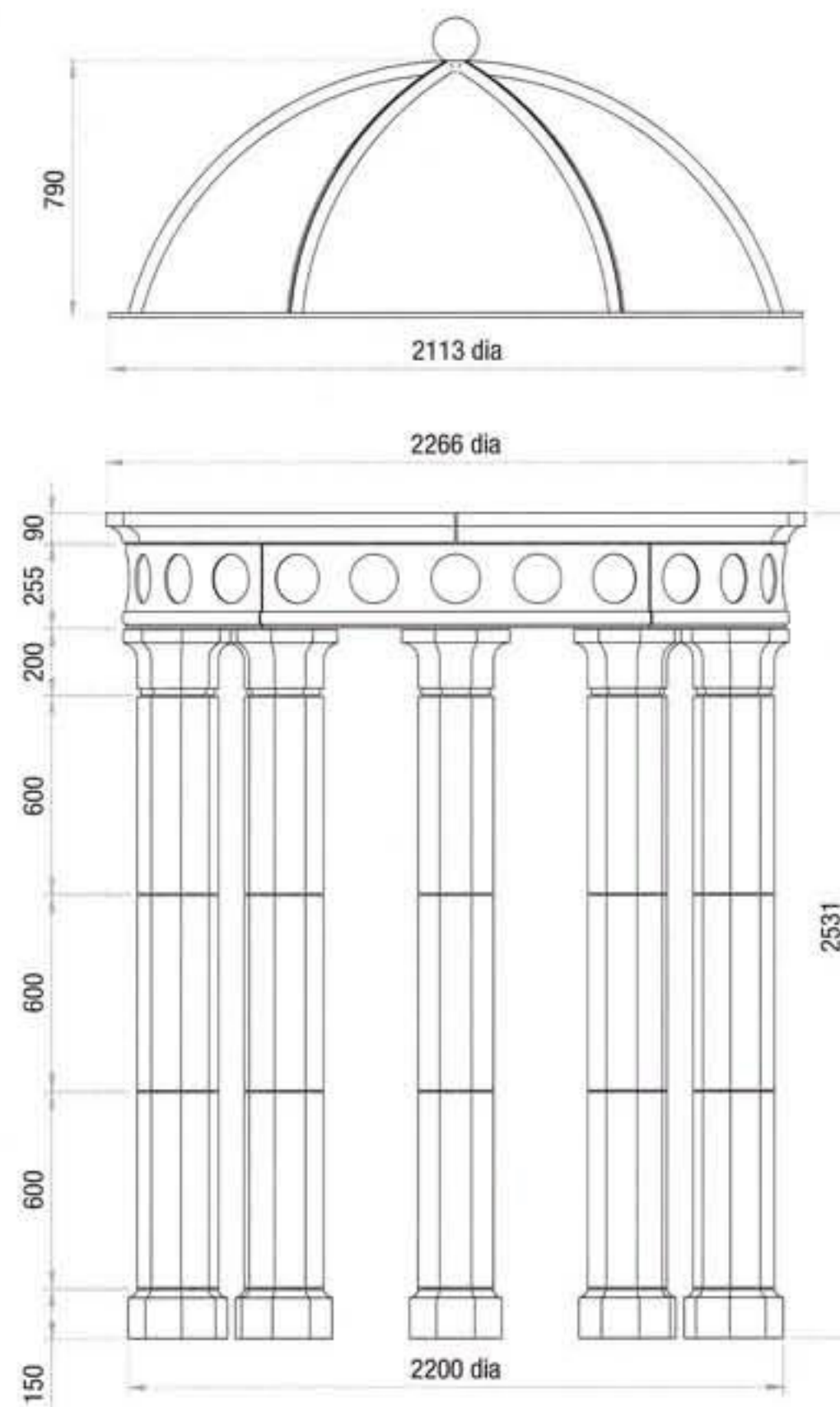

TP3

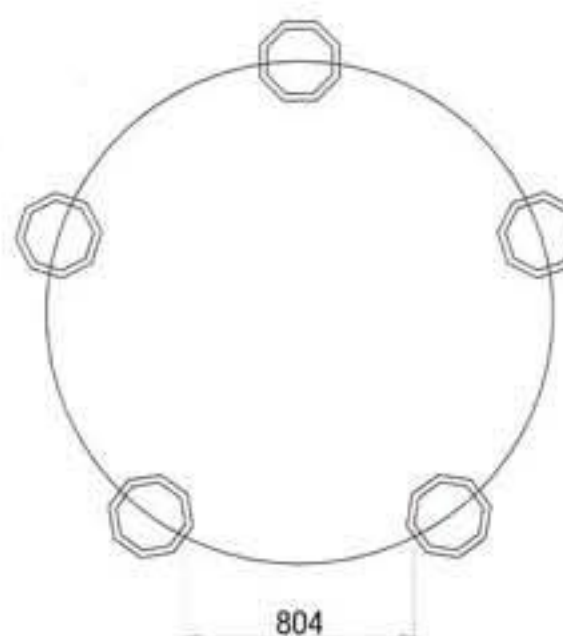

Total Weight: 1800Kg

Stepped Temple Floors

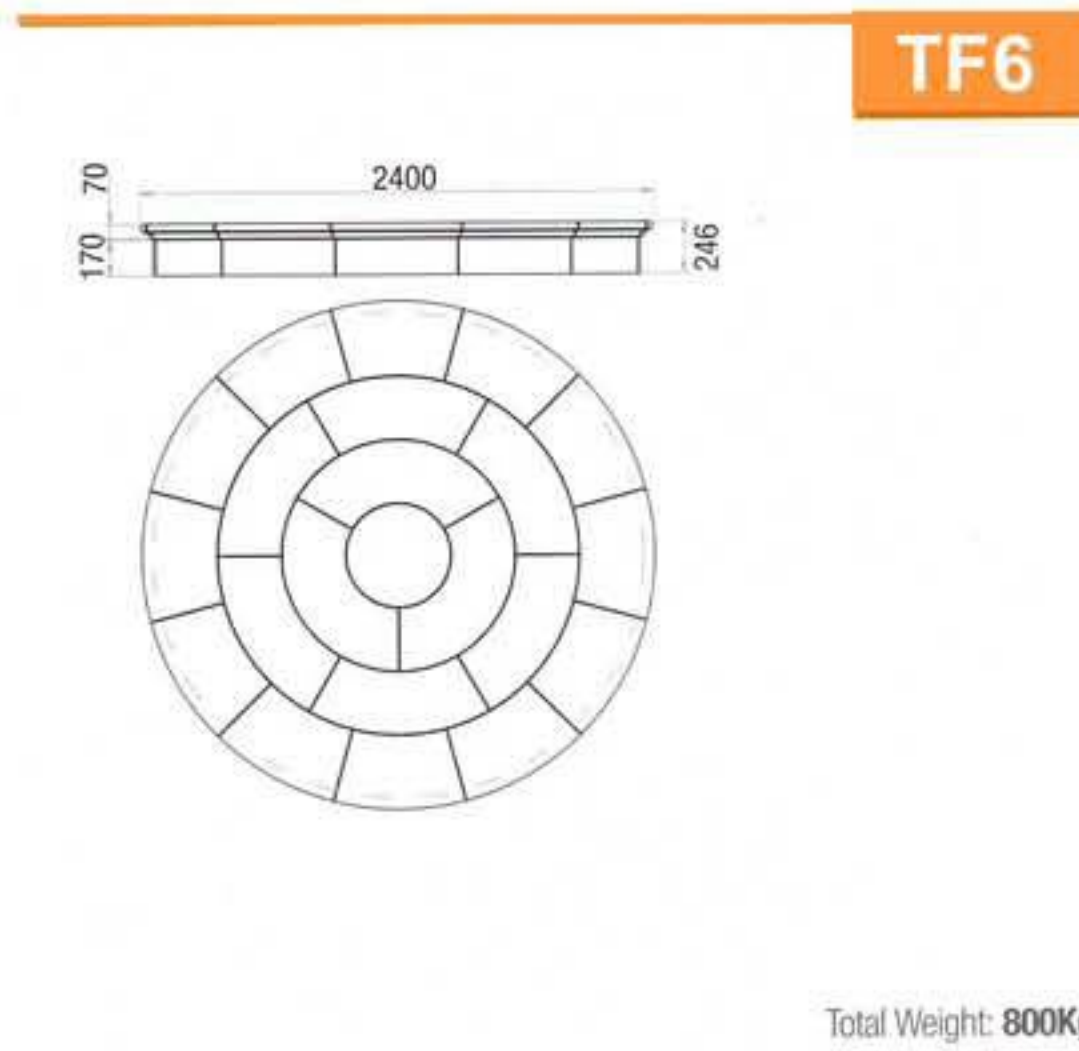
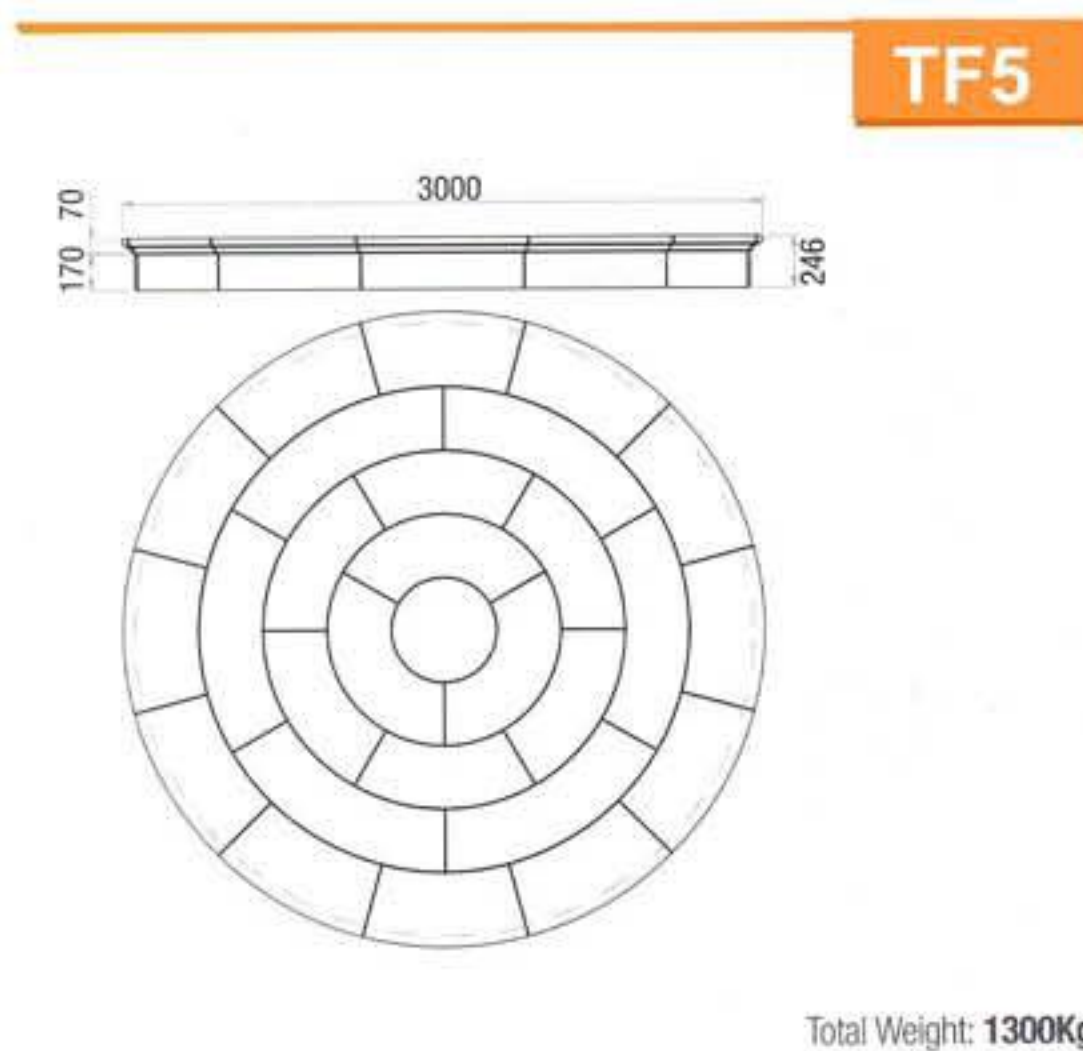
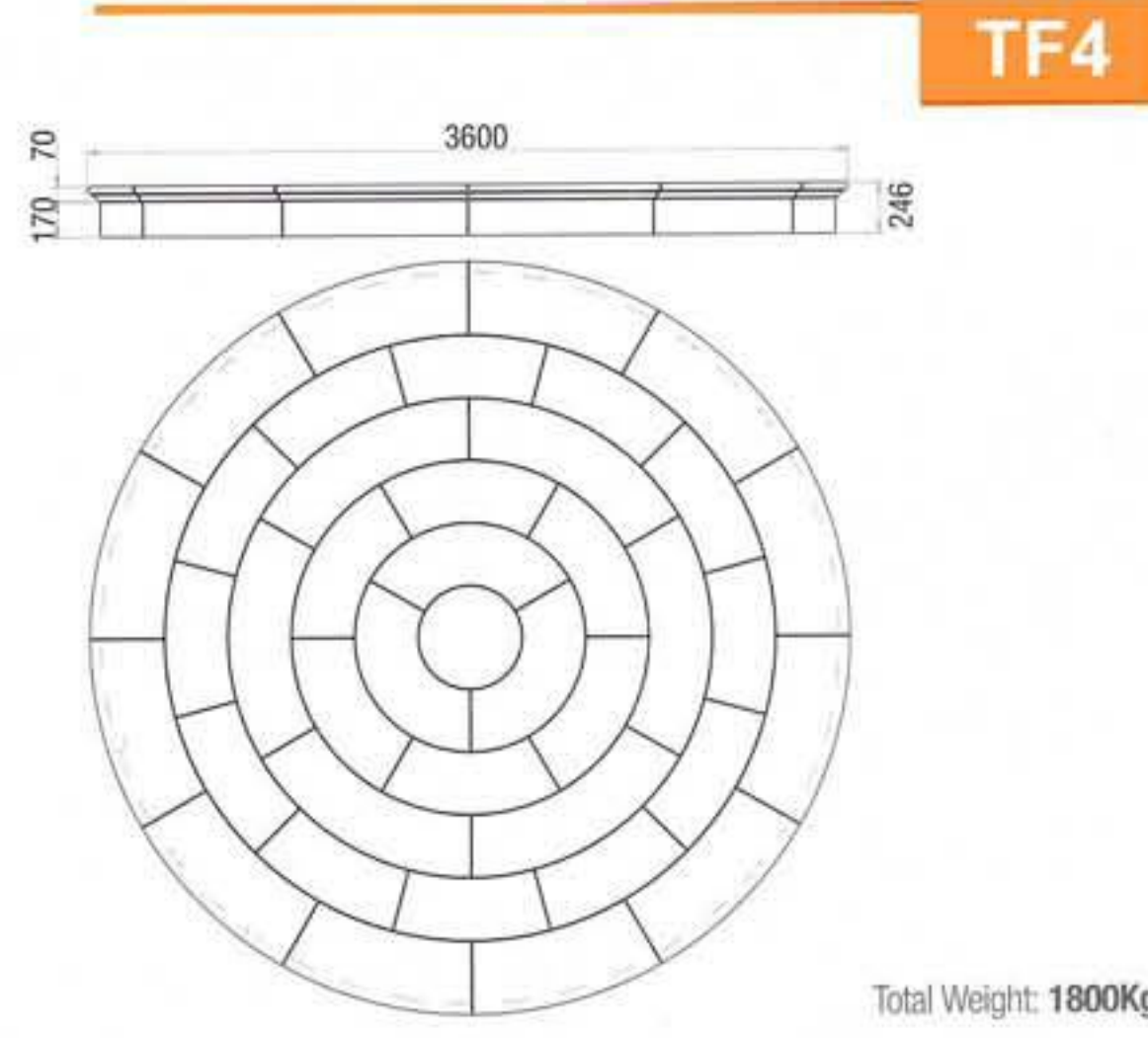
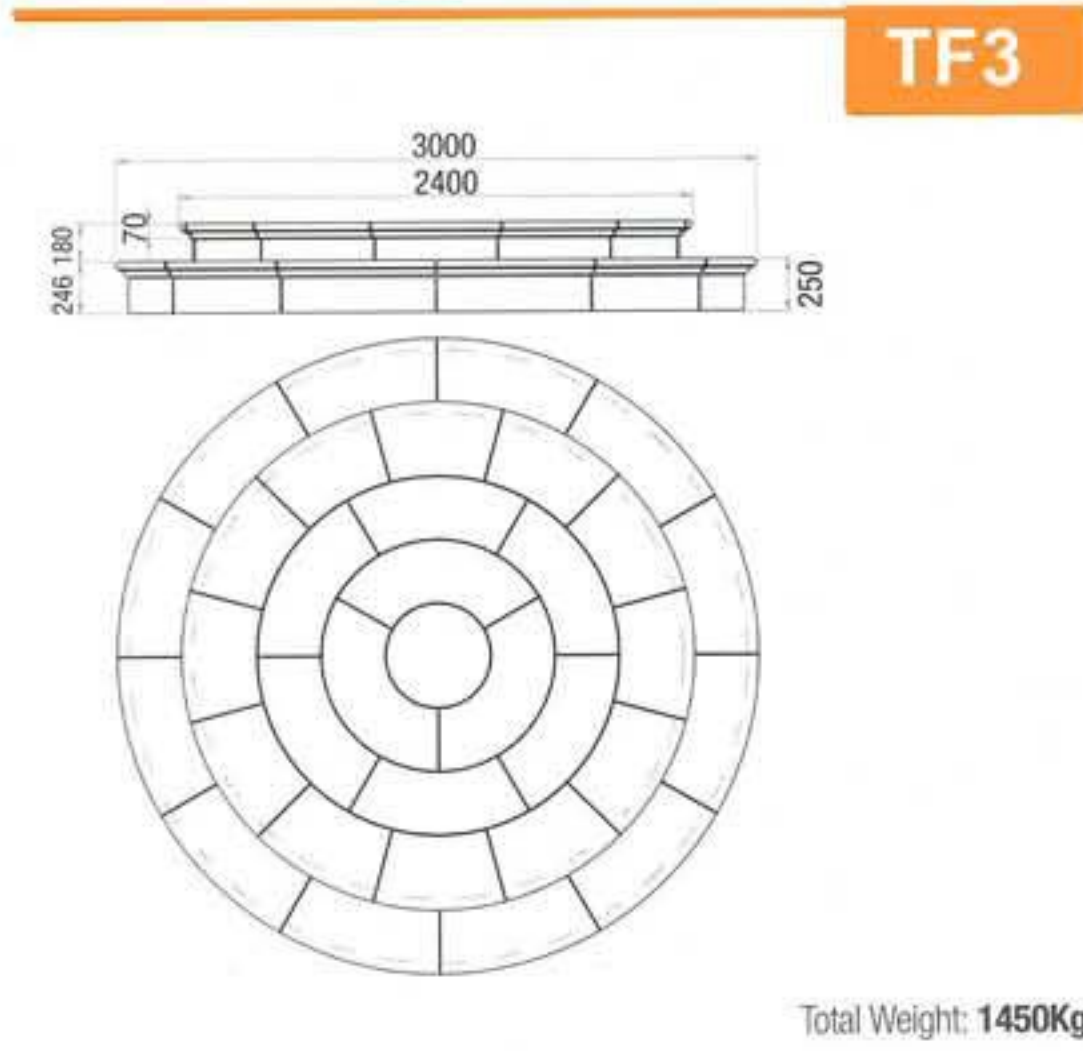
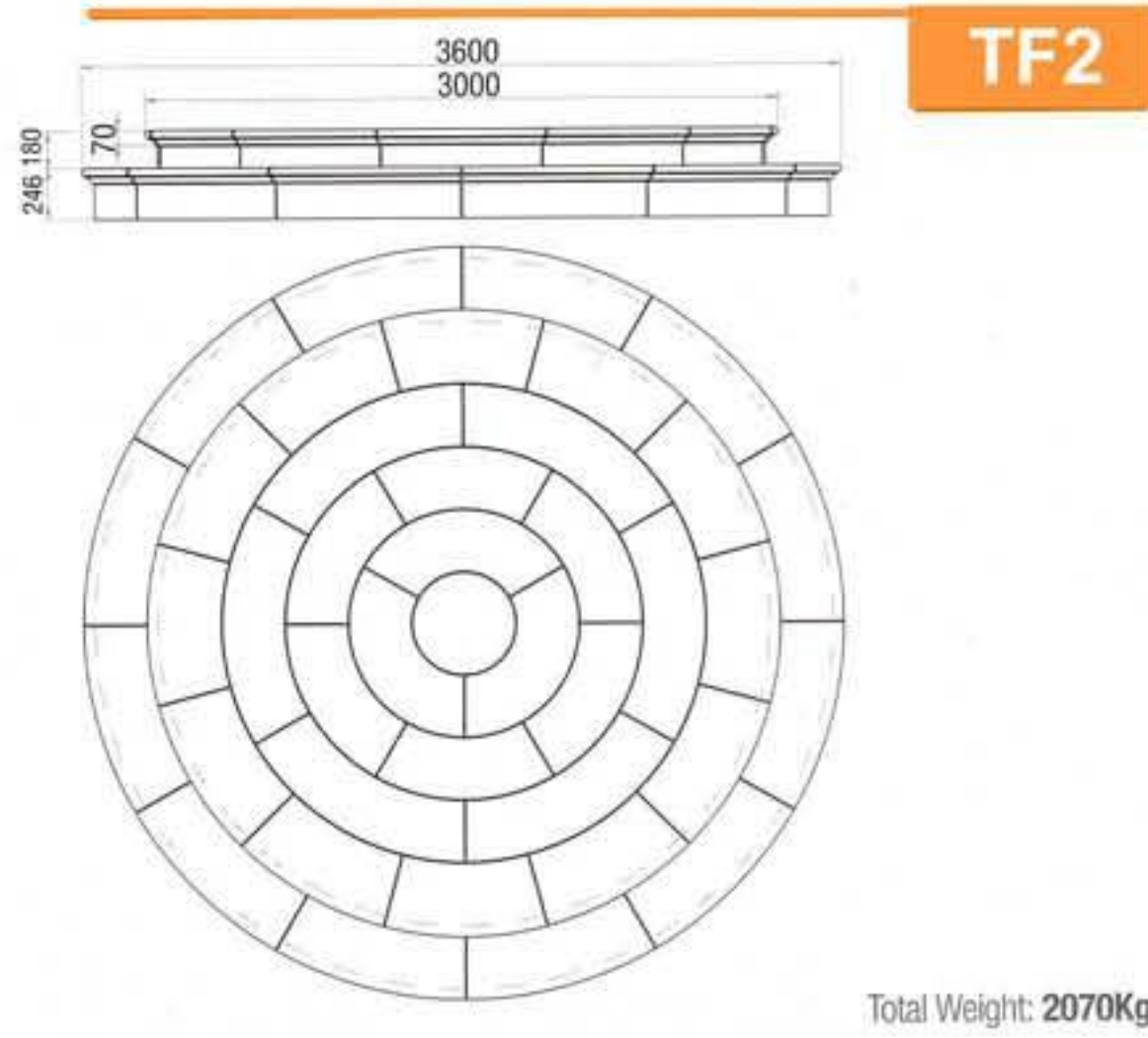
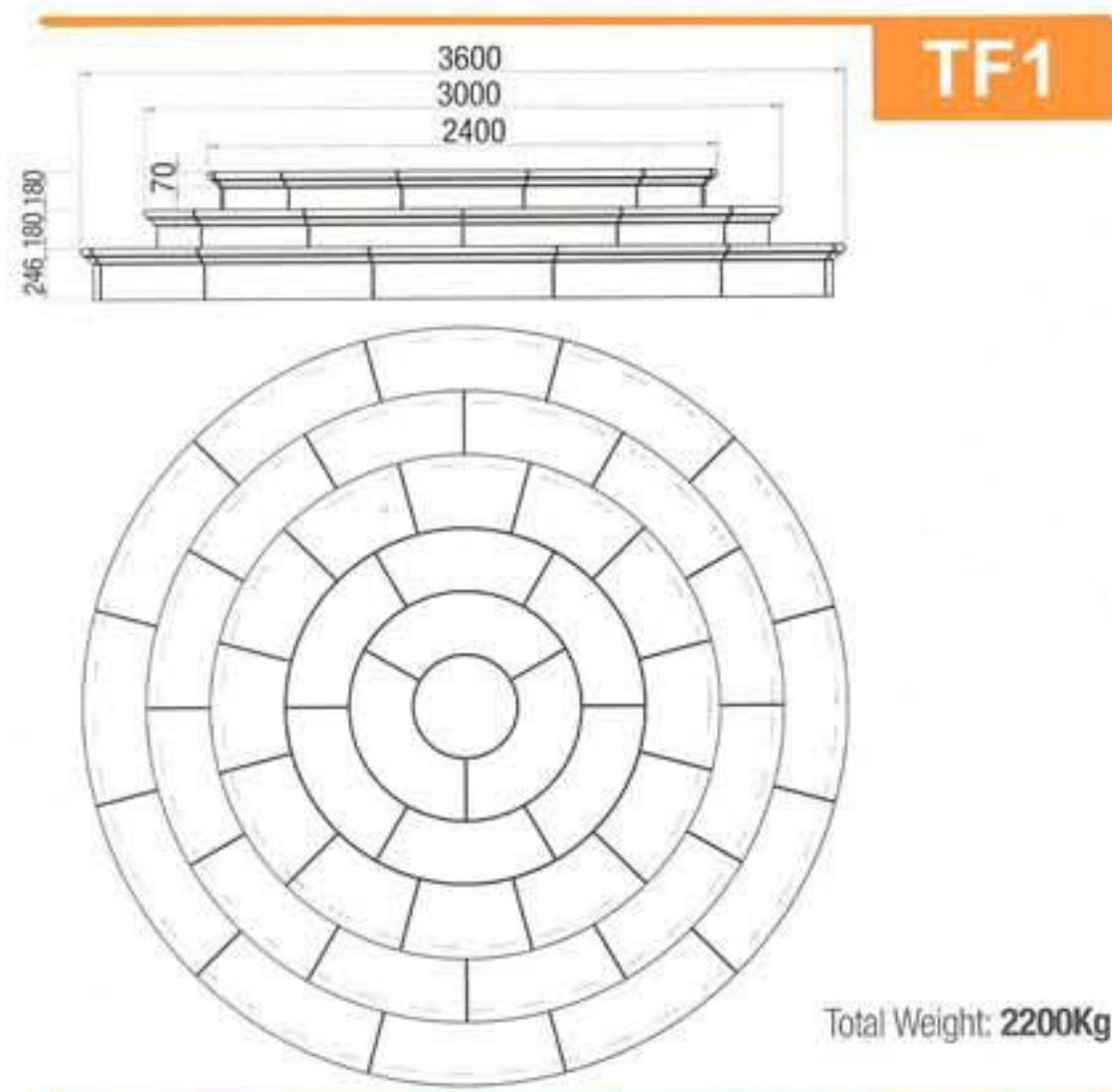



Columns & Pilasters

A Technical Data Sheet showing the recommended installation details is available on request.

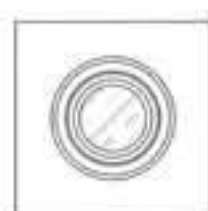
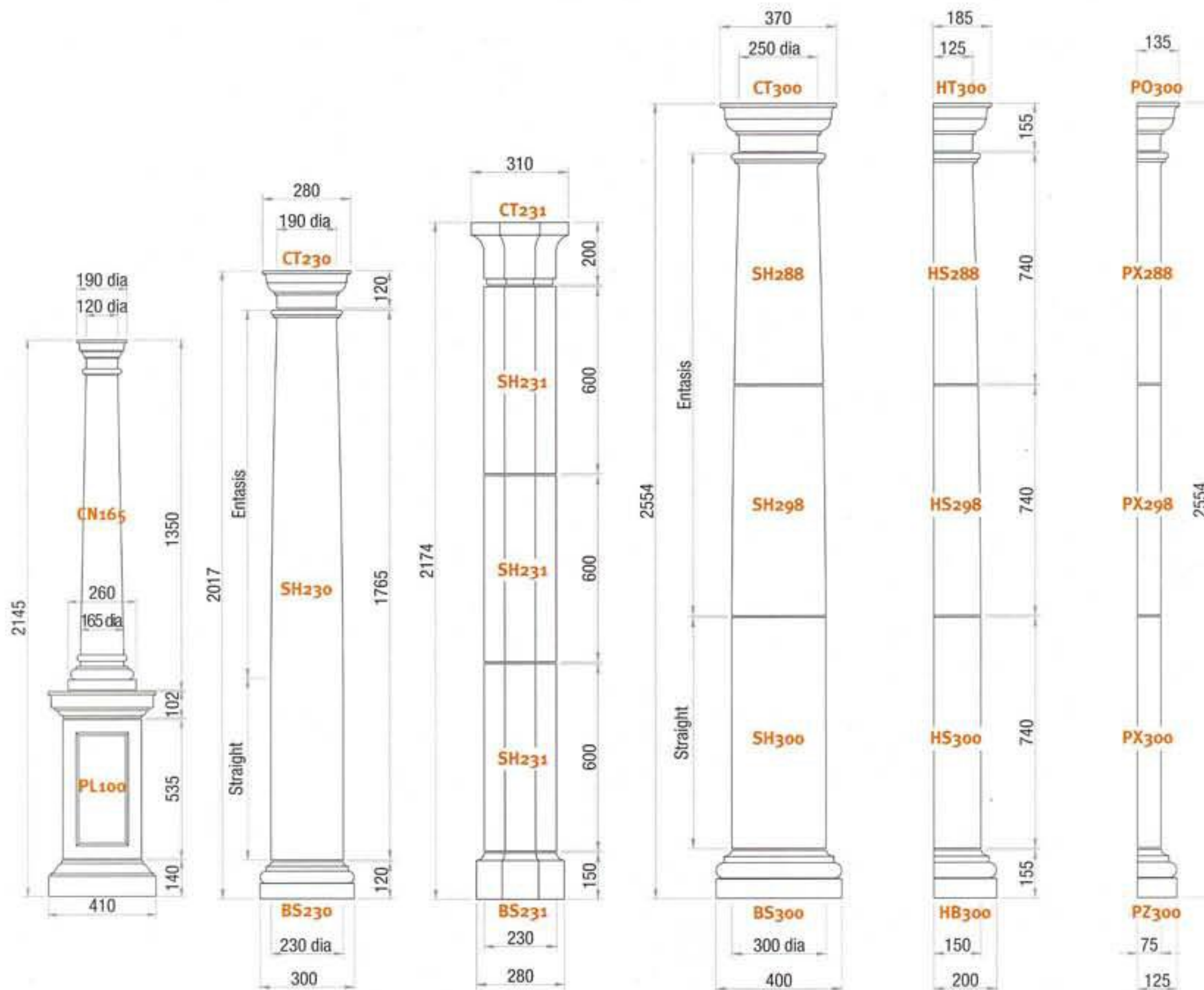

COLUMN

CN165

SUPPLIED SOLID ONLY.

Total Weight: 199Kg



COLUMN

CN230/Q

SUPPLIED SOLID OR WITH A 110 DIA CORE WITH ENTASIS.

Total Weight: 160Kg



COLUMN

CN231/Q

SUPPLIED SOLID OR WITH A 110 DIA CORE.

Total Weight: 200Kg



COLUMN

CN300/Q

SUPPLIED SOLID OR WITH A 110 DIA CORE WITH ENTASIS.

Total Weight: 380Kg



HALF COL.

HC300/Q

SUPPLIED SOLID OR WITH A 110 DIA CORE.

Total Weight: 190Kg



PILASTER

PR300

Total Weight: 126Kg

Columns & Pilasters



A Technical Data Sheet showing the recommended installation details is available on request.

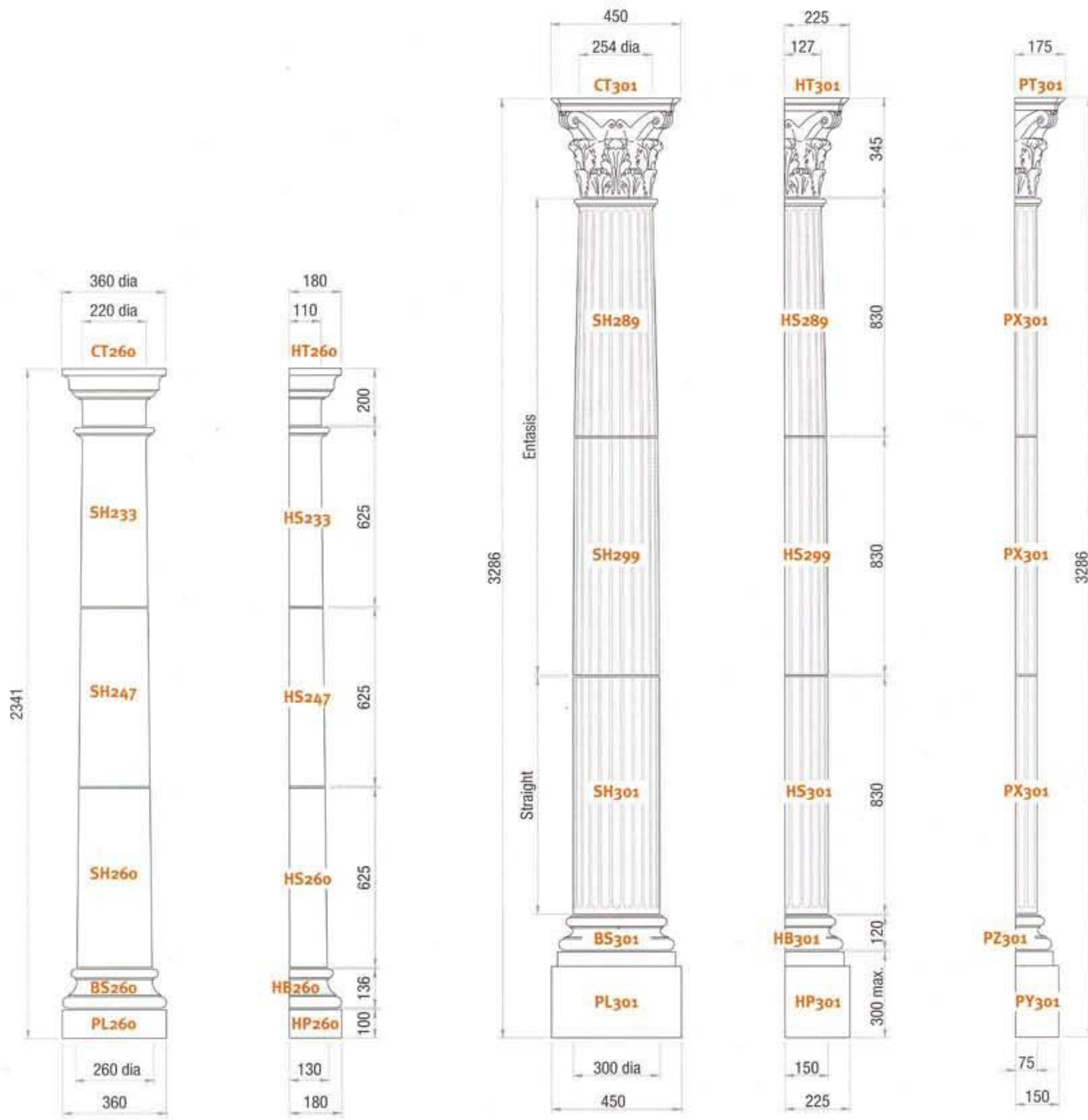

COLUMN
CN260/Q
SUPPLIED SOLID OR WITH A 110 DIA CORE.

Total Weight: 260Kg



HALF COL.
HC260/Q
SUPPLIED SOLID OR WITH A 110 DIA CORE.

Total Weight: 130Kg



COLUMN
CN301/Q
SOLID OR WITH A 110 DIA CORE.

Total Weight: 520Kg



HALF COL.
HC301/Q
SOLID OR WITH A 110 DIA CORE.

Total Weight: 260Kg



PILASTER
PR301

Total Weight: 300Kg





Columns & Pilasters

A Technical Data Sheet showing the recommended installation is available on request.

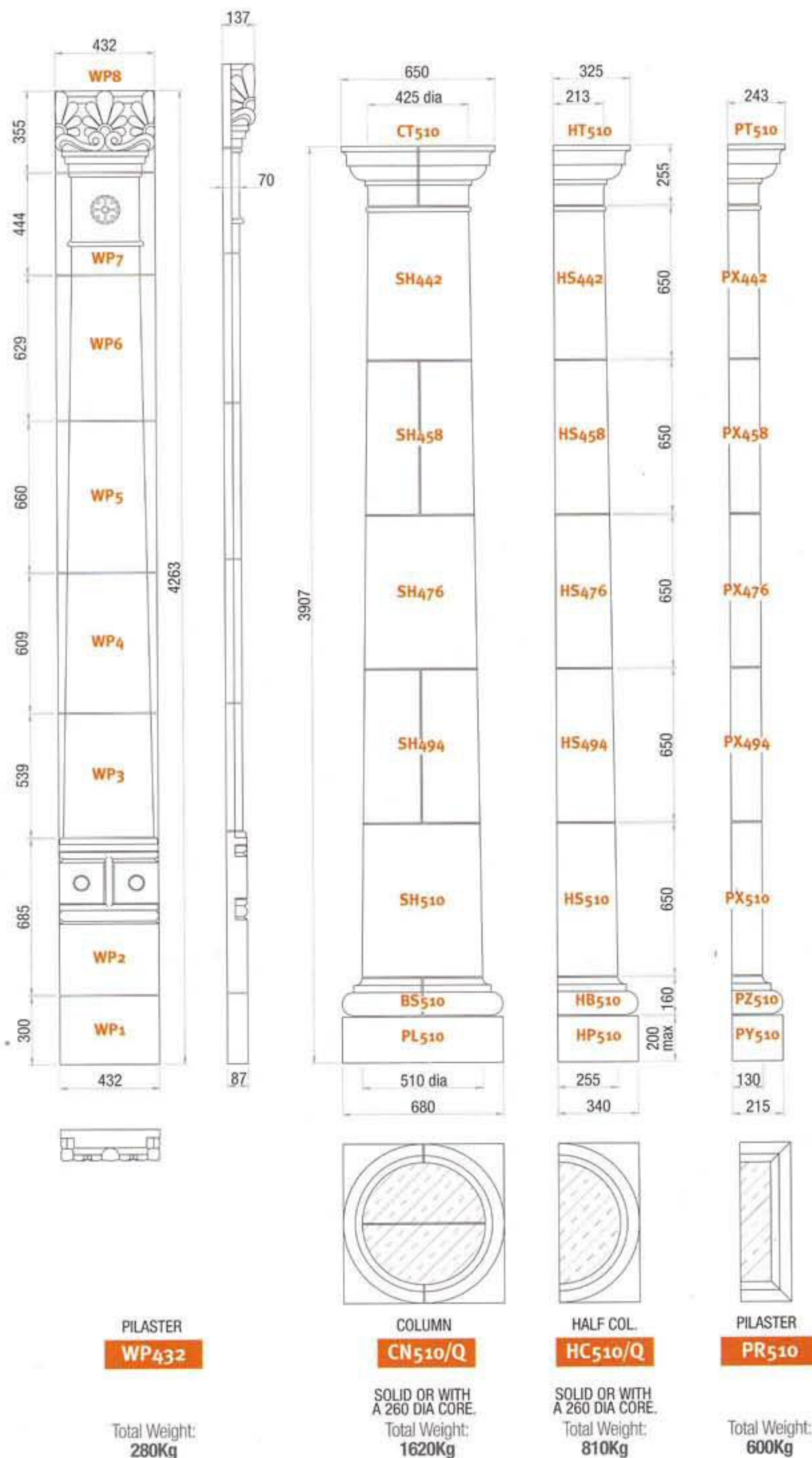

Columns & Pilasters

A Technical Data Sheet showing the recommended installation is available on request.

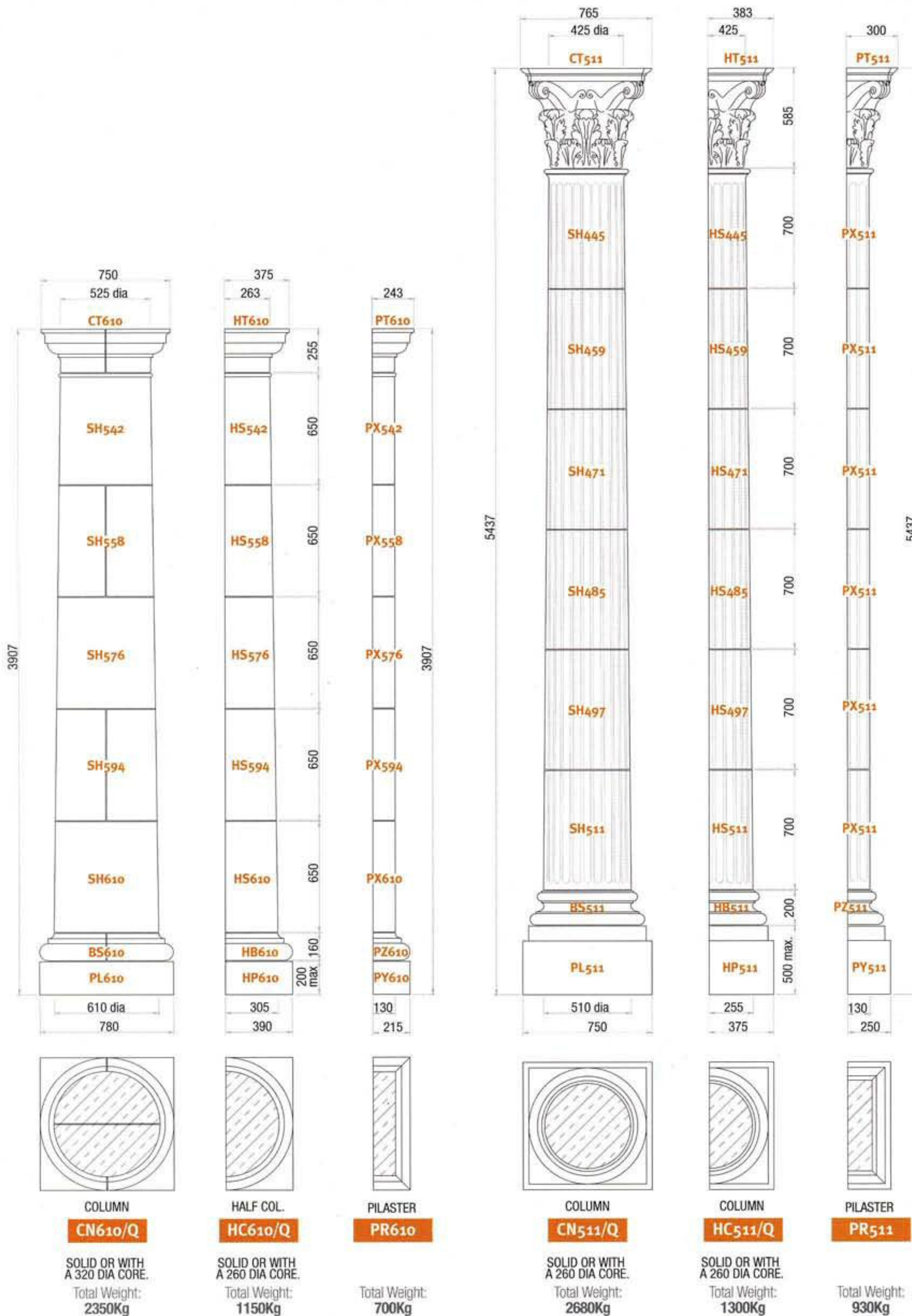

Column & Pilaster Capitals



CT230 Column Capital Tuscan

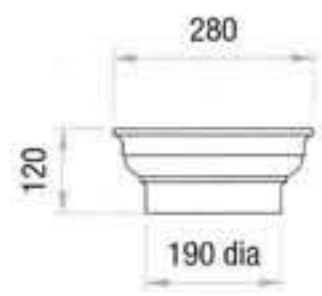

Weight: 12Kg

CT260 Column Capital Tuscan



Weight: 25Kg

CT300 Column Capital Tuscan

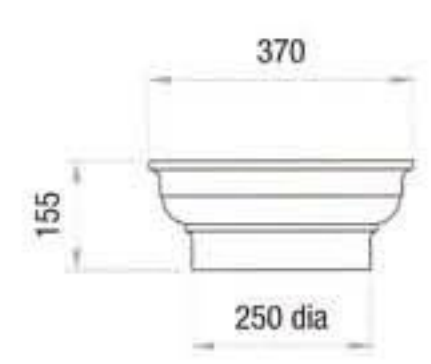

CT300
Weight: 26Kg

CT301 Column Capital Corinthian

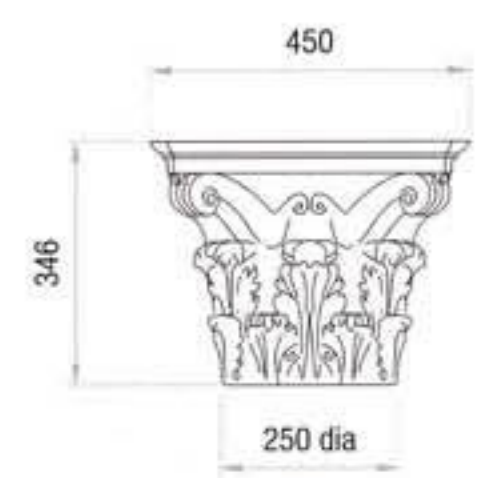

CT301
Weight: 60Kg

HT300 Pilaster Capital

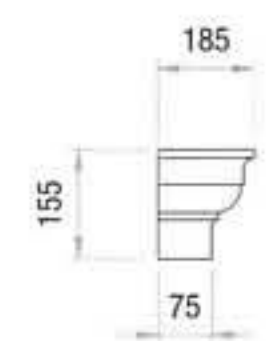

HT300
Weight: 10Kg

HT301 Pilaster Capital



HT301
Weight: 30Kg

Column & Pilaster Capitals



Ionic

Column Capital **CT302**

Pilaster Capital **HT302**

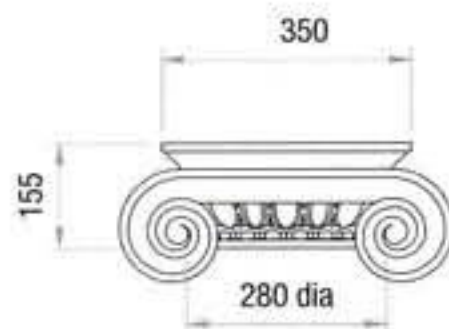

CT302

Weight: 35Kg



HT302

Weight: 20Kg

Doric

Column Capital **CT303**

Pilaster Capital **HT303**

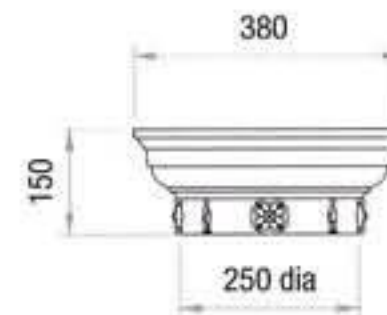

CT303

Weight: 26Kg



HT303

Weight: 10Kg

Tuscan

Column Capital **CT510**

Pilaster Capital **HT510**

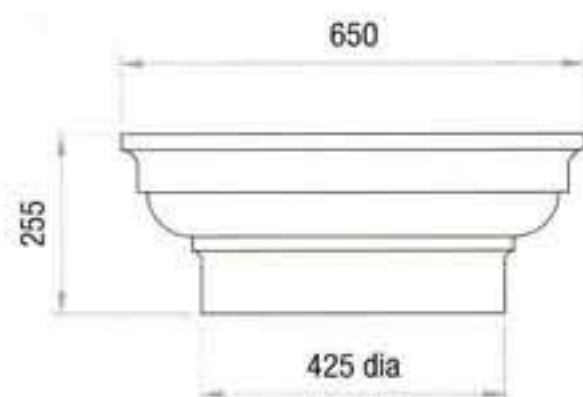

CT510

Weight: 130Kg

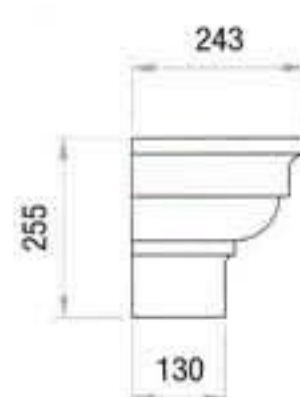

HT510

Weight: 50Kg

Corinthian

Column Capital **CT511**

Pilaster Capital **HT511**

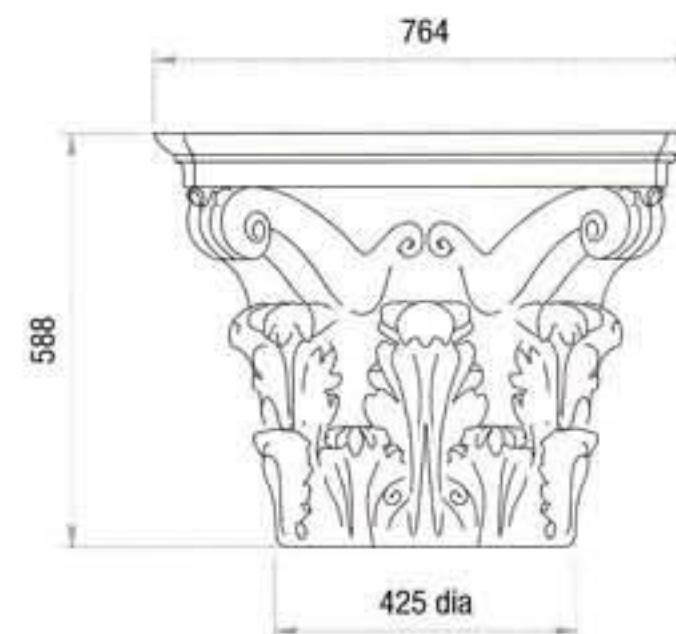

CT511

Weight: 280Kg

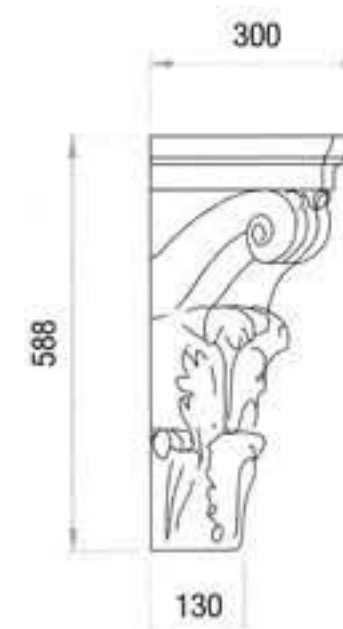

HT511

Weight: 130Kg

Column & Pilaster Capitals



CT512 Column Capital

Ionic

HT512 Pilaster Capital

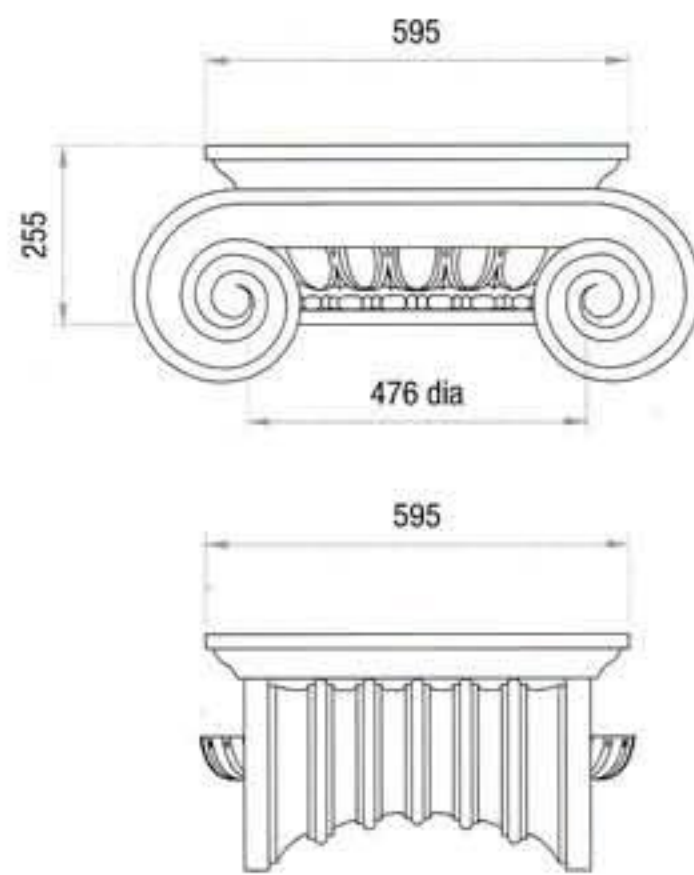

CT512

Weight: 180Kg



HT512

Weight: 80Kg

CT513 Column Capital

Doric

HT513 Pilaster Capital



CT513

Weight: 130Kg



HT513

Weight: 50Kg

CT610 Column Capital

Tuscan

HT610 Pilaster Capital

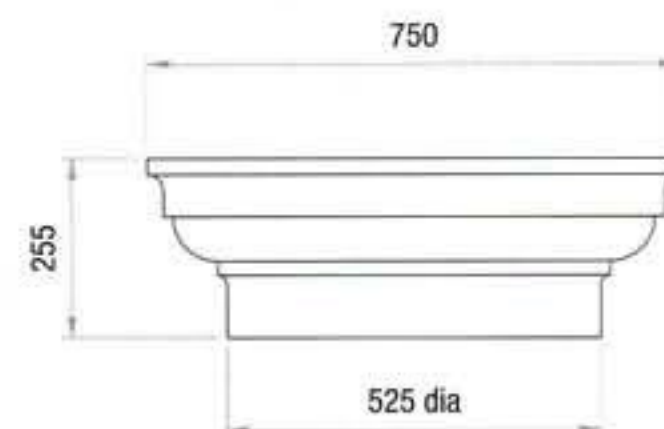

CT610

Weight: 180Kg



HT610

Weight: 60Kg

Treads & Risers

Treads and Risers are manufactured using a hard wearing granite aggregate to ensure long term durability. Slight shading variations may occur because of the difference in aggregates to other Amber Precast products.

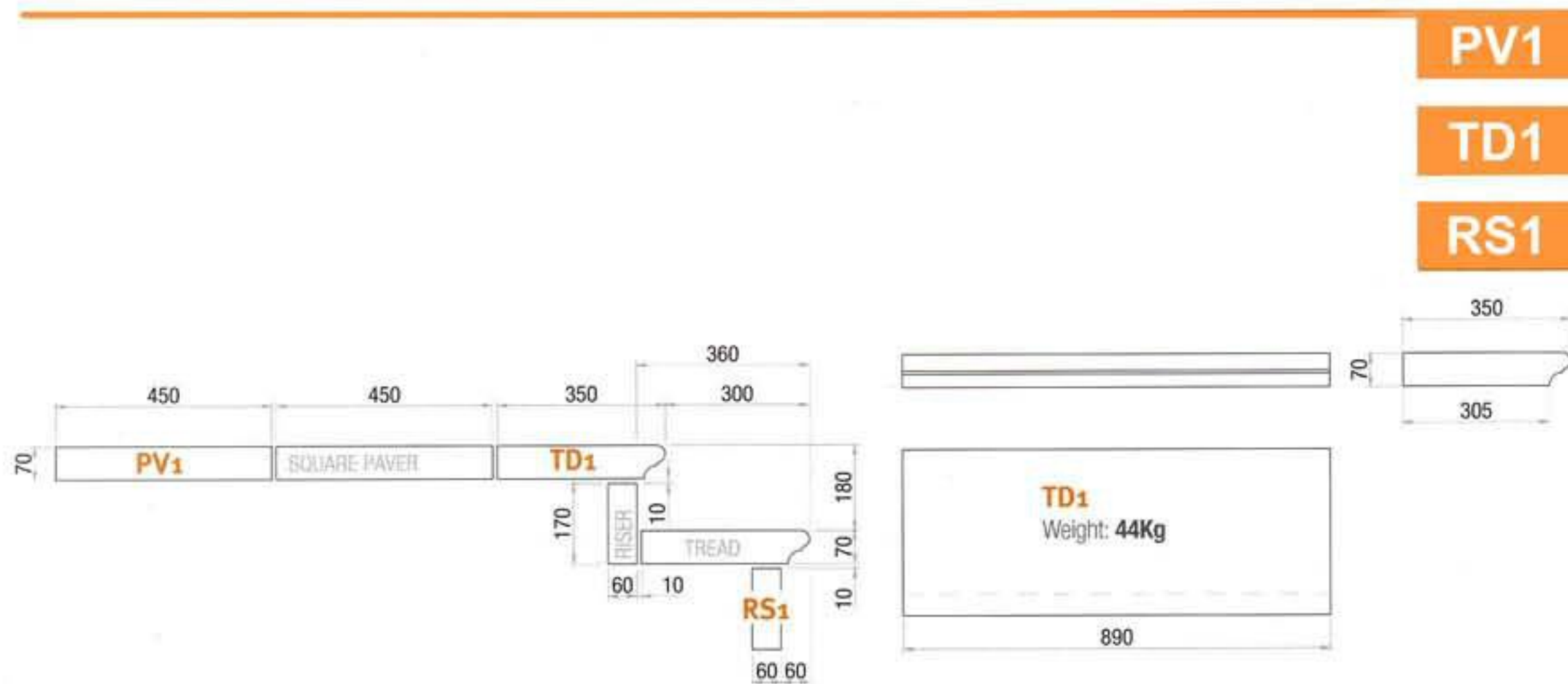

- PV1**
- TD1**
- RS1**

External 90° return to the left

TD1XL

External 90° return to the right

TD1XR

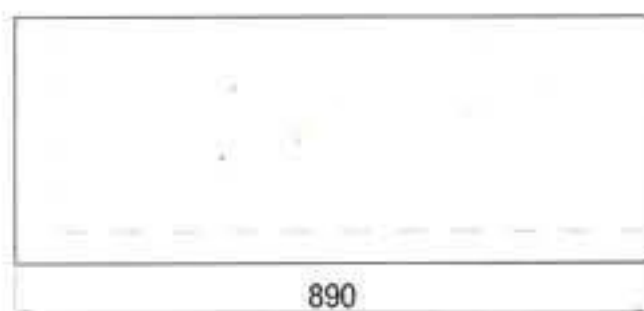

TD1XL
Weight: 43Kg



TD1XR
Weight: 43Kg

Internal 90° return to the left

TD1HL

Internal 90° return to the right

TD1HR

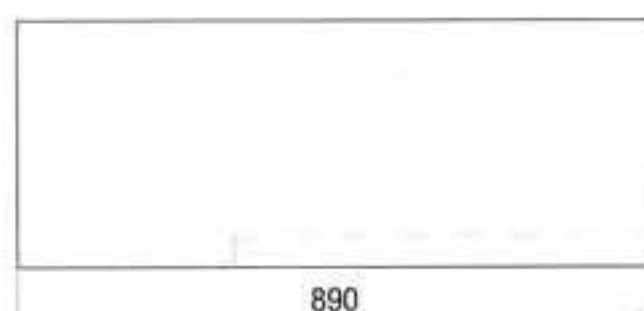

TD1HL
Weight: 45Kg



TD1HR
Weight: 45Kg

Treads and Risers



Treads and Risers are manufactured using a hard wearing granite aggregate to ensure long term durability. Slight shading variations may occur because of the difference in aggregates to other Amber Precast products.

TD1X45R External 45° return to the right

TD1X45L External 45° return to the left

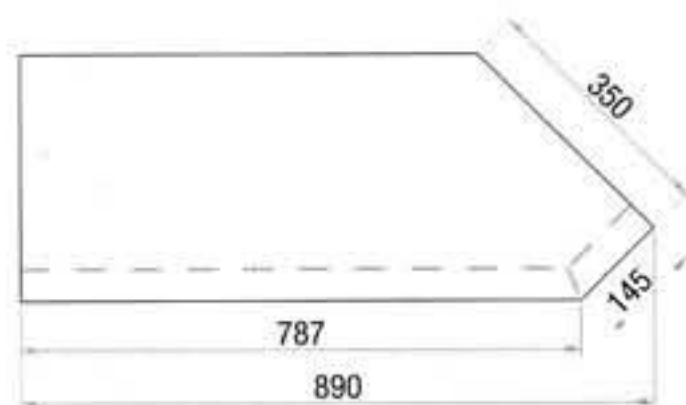

TD1X45R
Weight: 38Kg

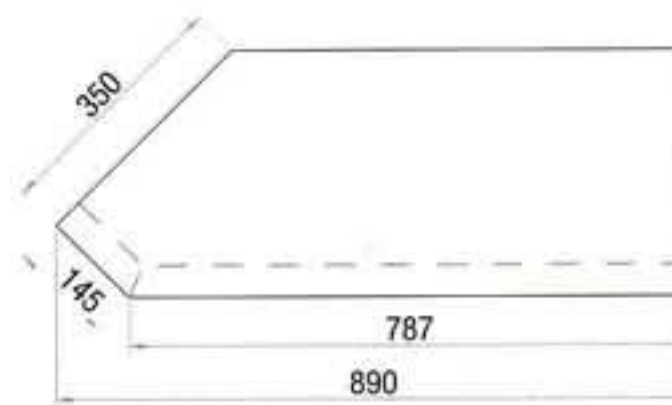

TD1X45L
Weight: 38Kg

TD1H45R Internal 45° return to the right

TD1H45L Internal 45° return to the left

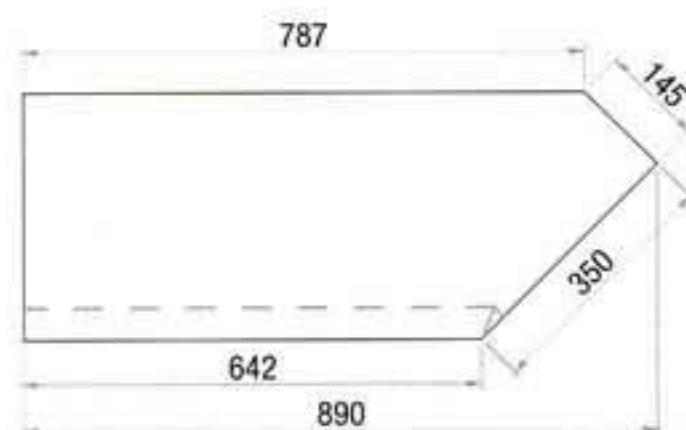

TD1H45R
Weight: 39Kg

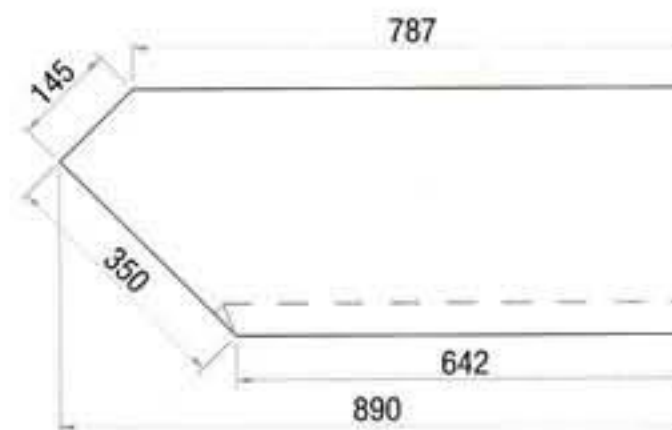

TD1H45L
Weight: 39Kg

TD1XC-1200

TD1XC-1500

TD1XC-1800

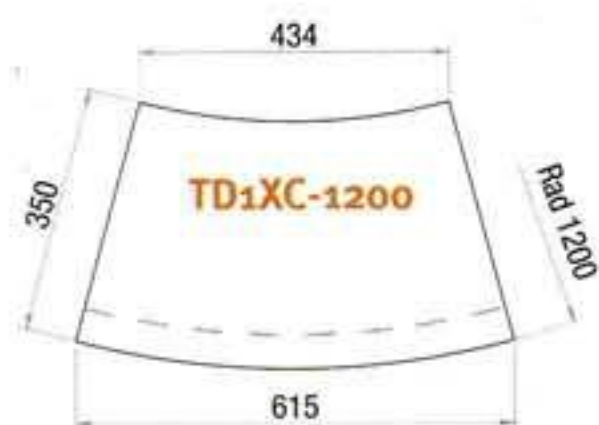

Weight: 26Kg

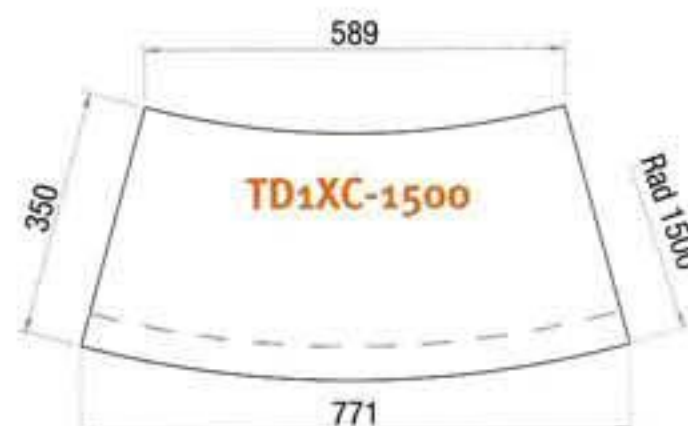

Weight: 34Kg

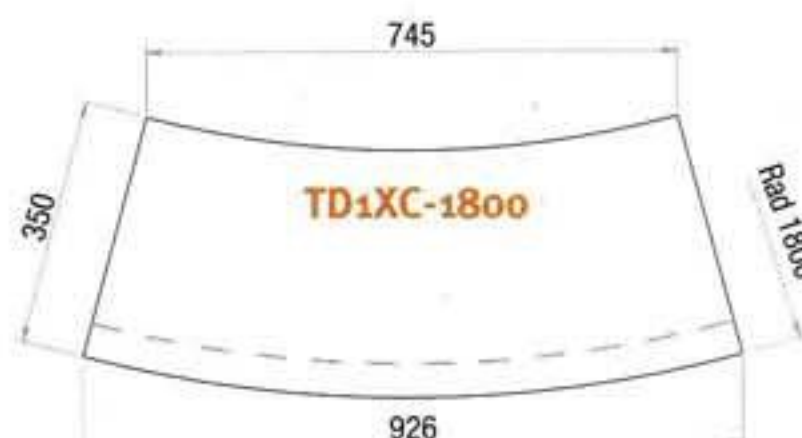

Weight: 41Kg

Treads & Risers

Treads and Risers are manufactured using a hard wearing granite aggregate to ensure long term durability. Slight shading variations may occur because of the difference in aggregates to other Amber Precast products.



RA1

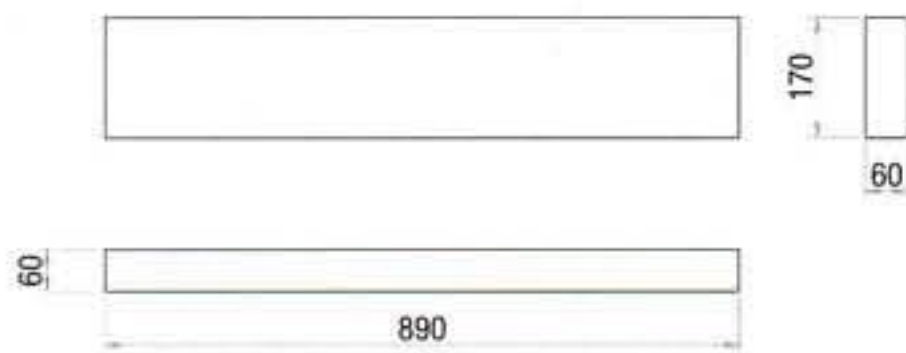

RA1
Weight: 17Kg

External return **RA1X45**

Internal return **RA1H45**

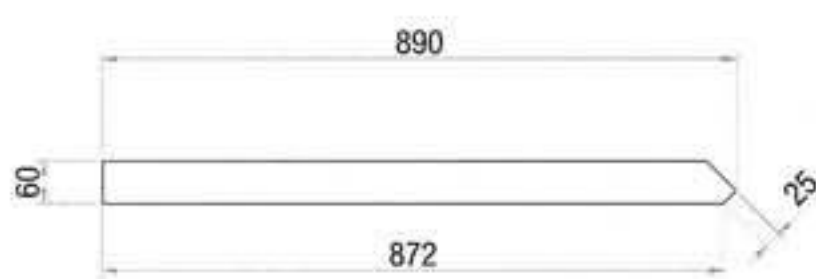

RA1X45
Weight: 17Kg

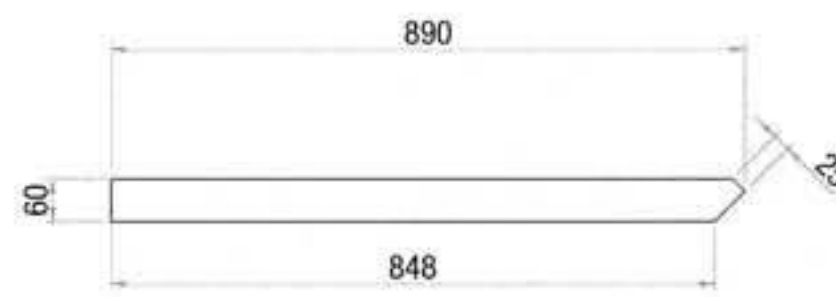

RA1H45
Weight: 17Kg

RA1XC-1744

RA1XC-1444

RA1XC-1144

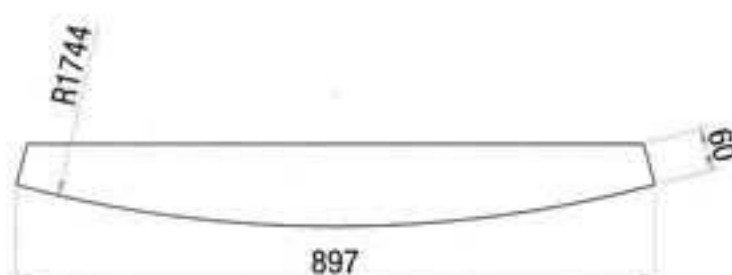

RA1XC-1744
Weight: 27Kg

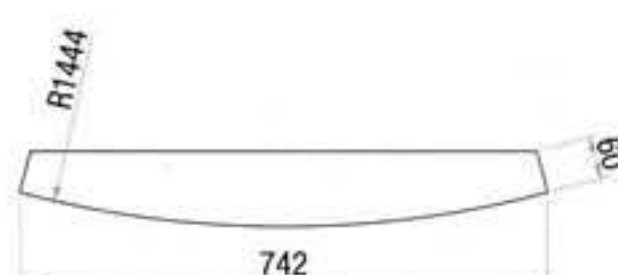

RA1XC-1444
Weight: 21Kg

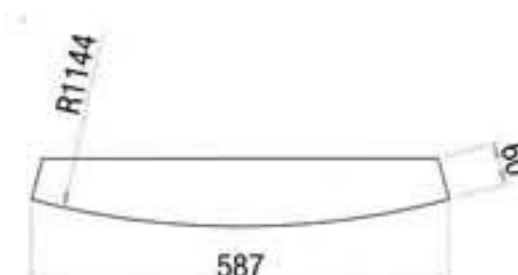

RA1XC-1144
Weight: 15Kg

Asymmetrical Copings



All copings are supplied in 600mm lengths. Kneelers/Apex stones to suit can be manufactured to order.

When ordering please state radius dimension R. All weights are shown in Kg/m.

Special ancillary items to match copings are available, when ordering precede by coping reference (eg, CP1-X90).

Typical Detail

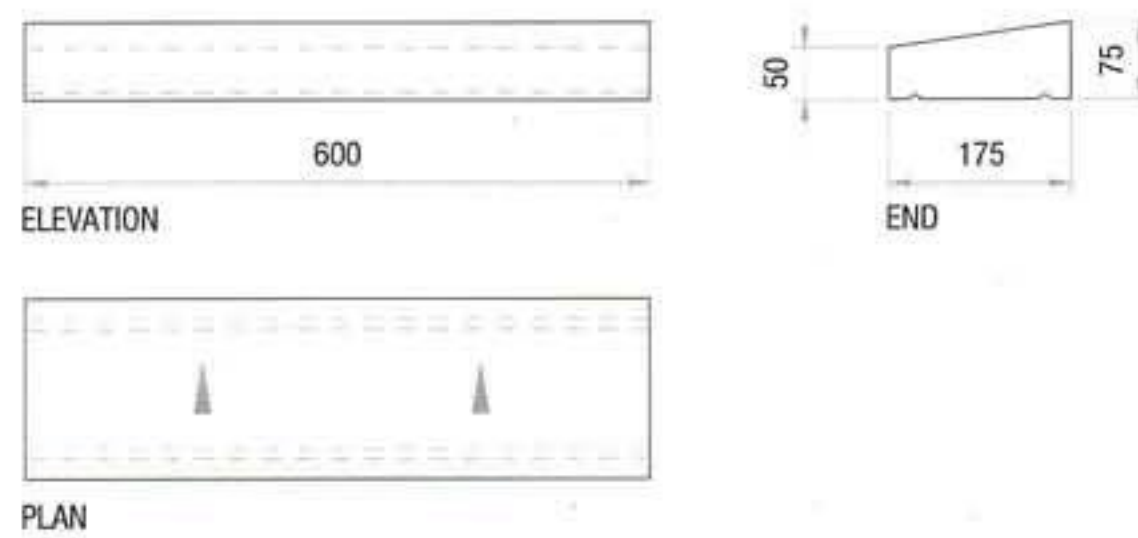

CP

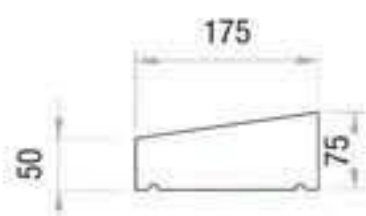

CP1
Weight: 23Kg

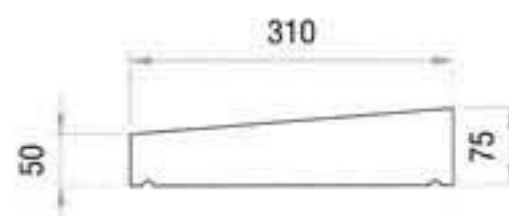

CP12
Weight: 41Kg

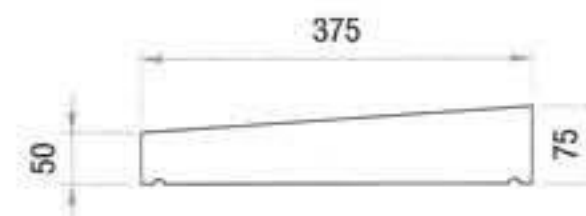

CP7
Weight: 50Kg

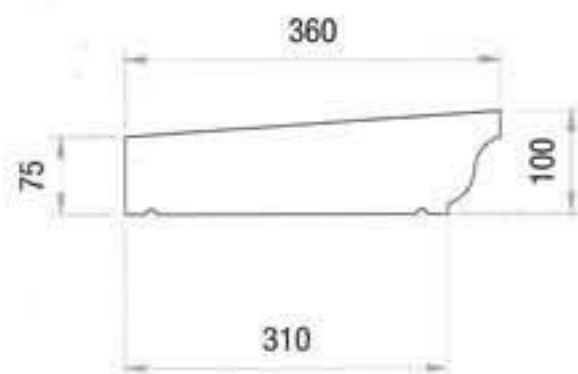

CP15
Weight: 62Kg

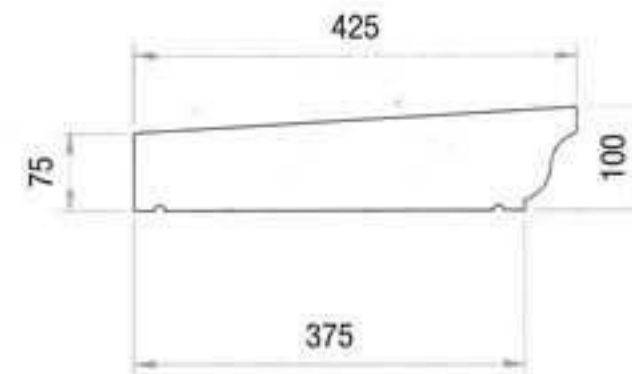

CP16
Weight: 74Kg



Asymmetrical Copings

All copings are supplied in 600mm lengths. Kneelers/Apex stones to suit can be manufactured to order.

When ordering please state radius dimension R be

Special ancillary items to match copings are available, when ordering precede by coping reference (eg, CP1-X90)

- P90
- UC
- DC

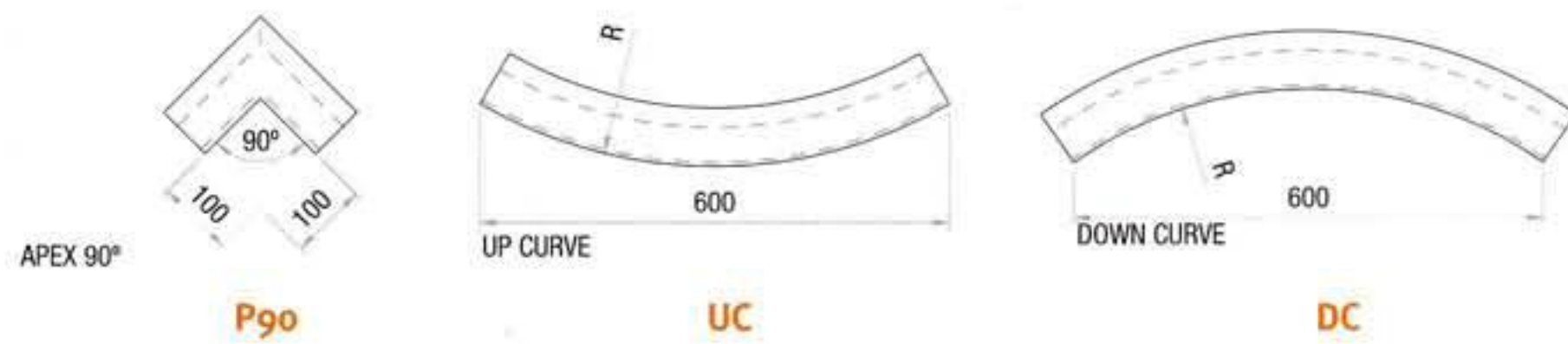

- XC
- HC
- X90
- H90

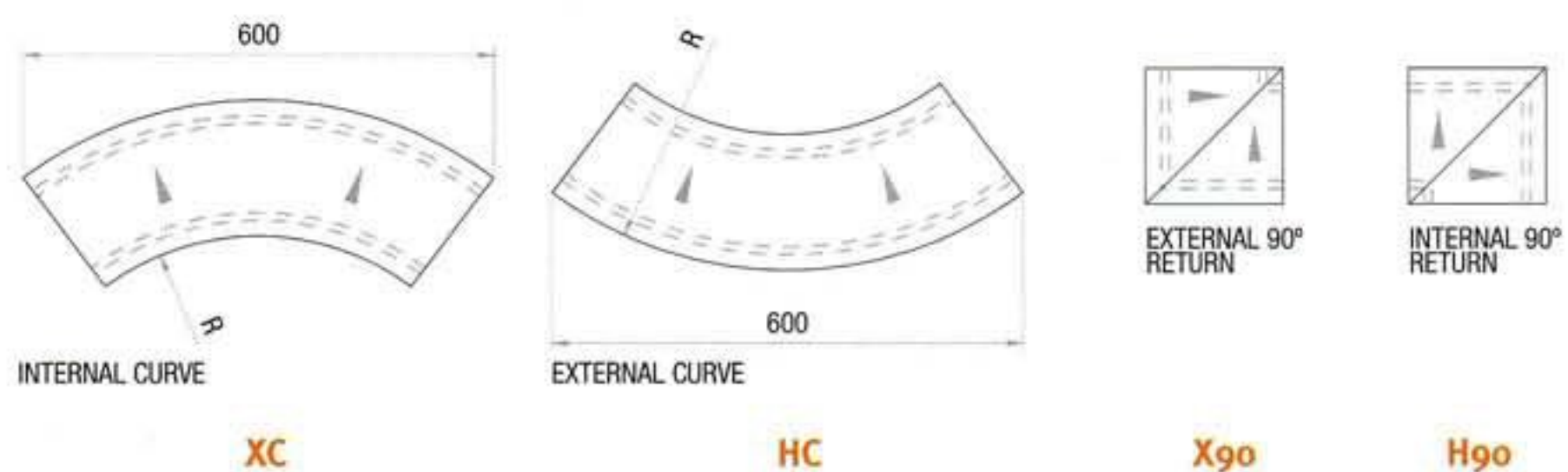

Symmetrical Copings



All copings are generally supplied in 600mm lengths. Weights are shown in Kg/m.

Special ancillary items to match copings are available, when ordering precede by coping reference (eg, CP9-P90)

Typical Detail

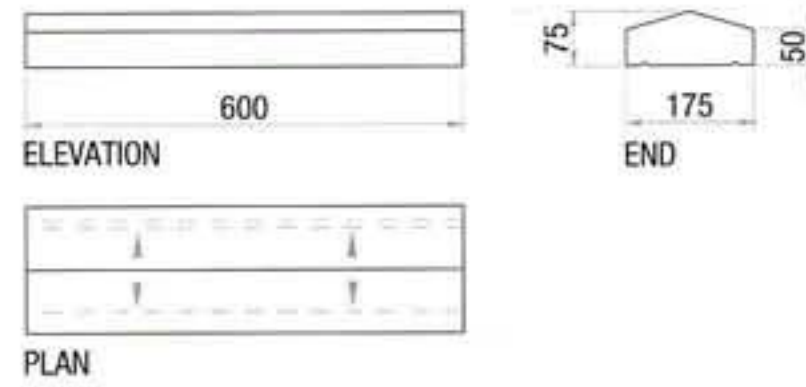

* denotes products in The Homestyle Range

CP

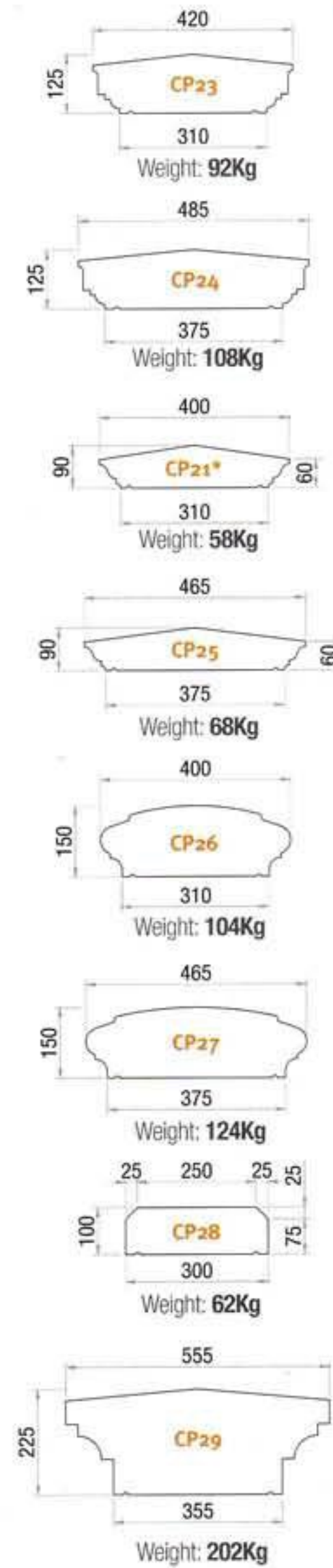
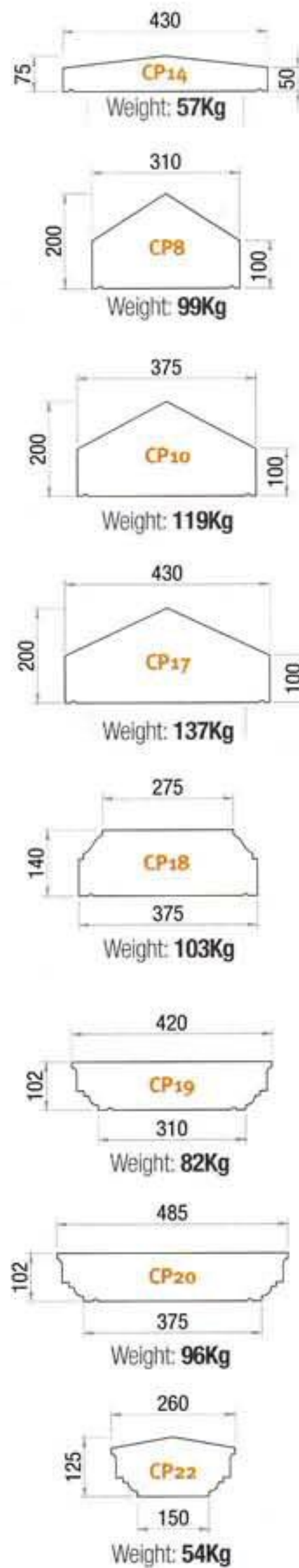
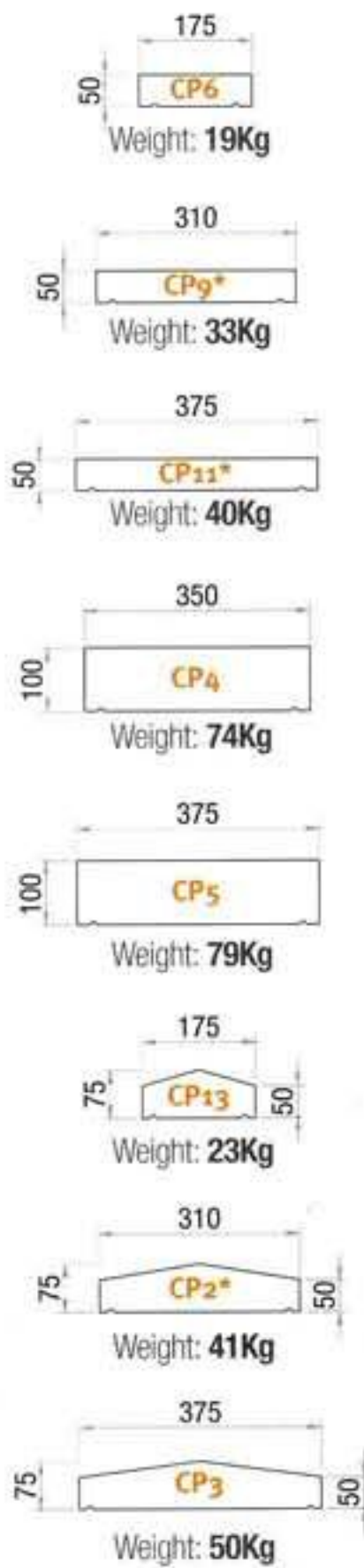



Symmetrical Copings

Copings on this page can be manufactured to suit requirements.

P90

UC

DC

APEX 90°

P90

UP CURVE

UC

DOWN CURVE

DC

U45

U90

UP 45° RETURN

U45

UP 90° RETURN

U90

D45

D90

X90

DOWN 45° RETURN

D45

DOWN 90° RETURN

D90

90° RETURN

X90

E

J

C

STOP END

E

JUNCTION "T"

J

CURVE ON PLAN

C

Corbels

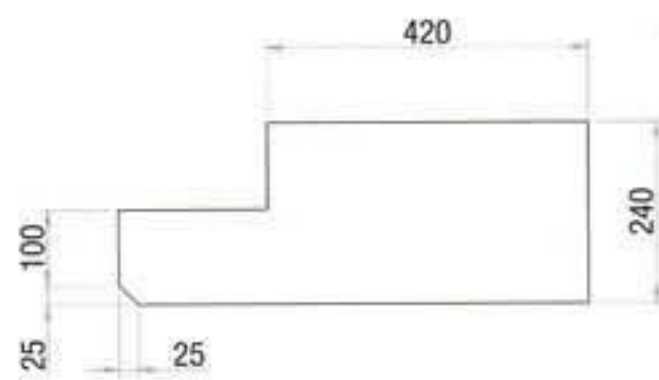

Left **SO60L**

Right **SO60R**

Weight: 48Kg

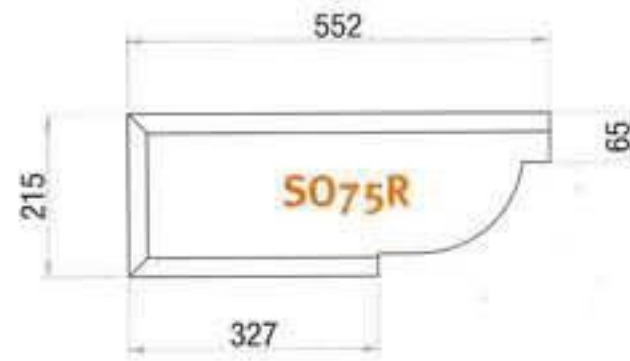

Left **SO75L**

Right **SO75R**

Weight: 27Kg

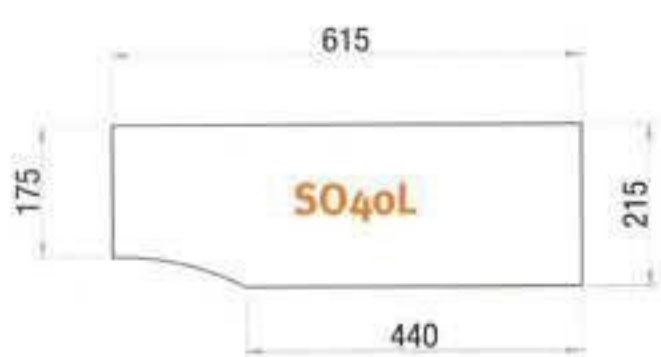

Left **SO40L**

Right **SO40R**

Weight: 27Kg



Corbels

S01

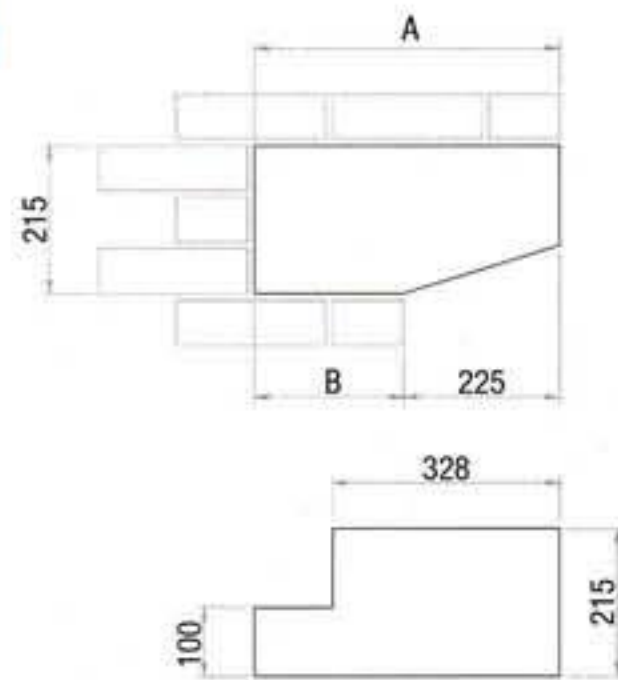

Code	A	B	Weight (kg)
S01L-440 S01R-440	440	215	34
S01L-553 S01R-553	553	328	39
S01L-665 S01R-665	665	440	44

S02

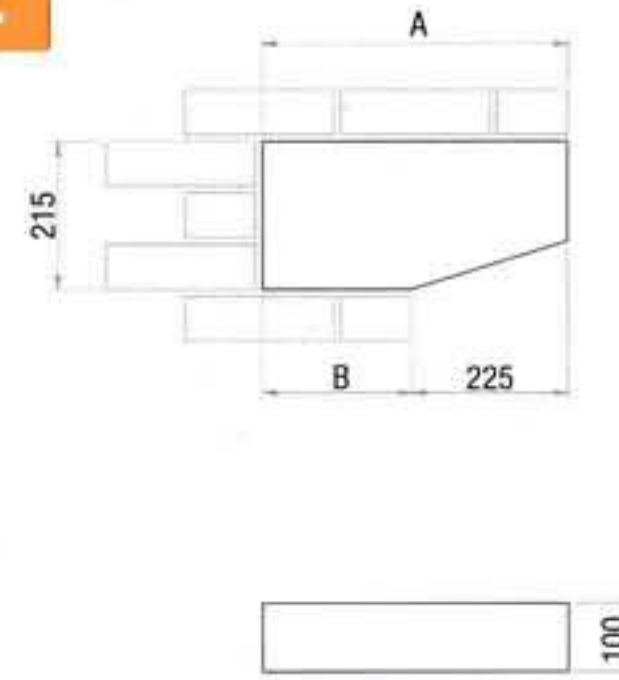

Code	A	B	Weight (kg)
S02L-440 S02R-440	440	215	18
S02L-553 S02R-553	553	328	23
S02L-665 S02R-665	665	440	28

S03

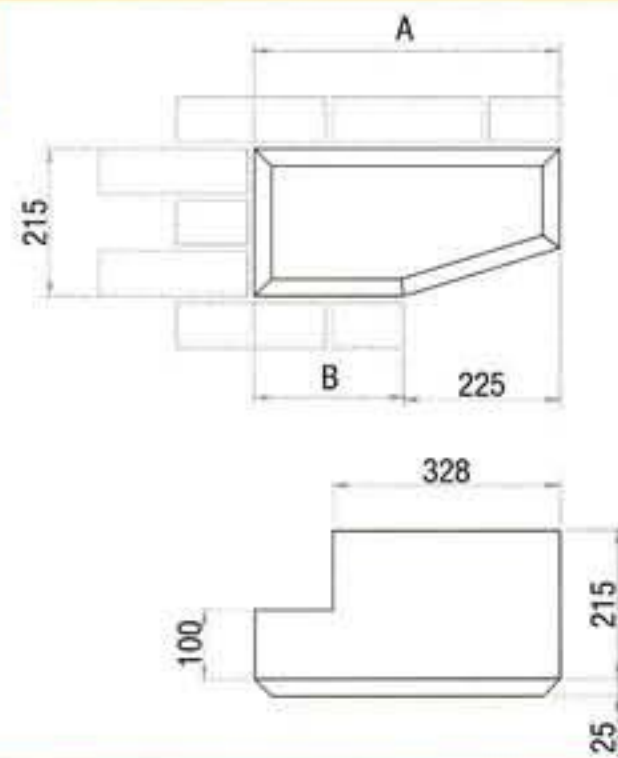

Code	A	B	Weight (kg)
S03L-440 S03R-440	440	215	38
S03L-553 S03R-553	553	328	44
S03L-665 S03R-665	665	440	50

S04

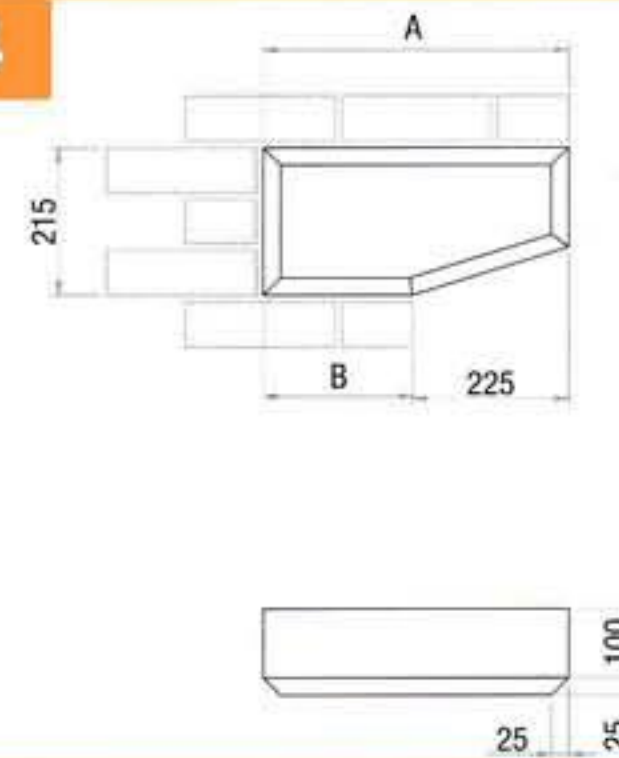

Code	A	B	Weight (kg)
S04L-440 S04R-440	440	215	22
S04L-553 S04R-553	553	328	28
S04L-665 S04R-665	665	440	34

S05

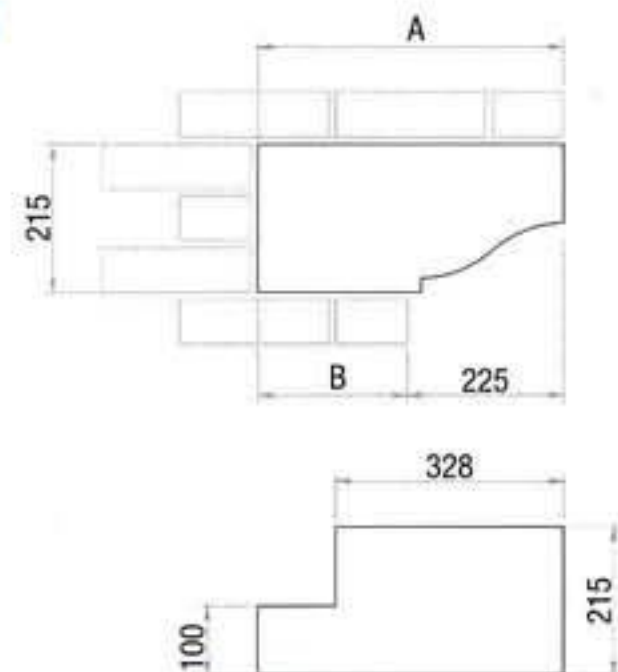

Code	A	B	Weight (kg)
S05L-440 S05R-440	440	215	37
S05L-553 S05R-553	553	328	43
S05L-665 S05R-665	665	440	48

S06

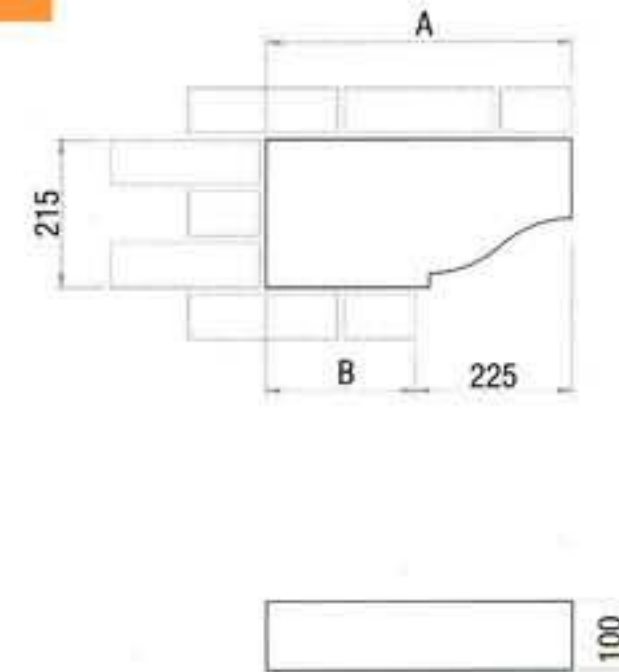

Code	A	B	Weight (kg)
S06L-440 S06R-440	440	215	17
S06L-553 S06R-553	553	328	23
S06L-665 S06R-665	665	440	28

Pier Caps



Pier Caps can be manufactured either four times weathered to a point or with a square recess to locate a stone sphere or alternative finial. Dotted lines on the drawing indicates aperture, please specify which is required when ordering (pier caps with aperture are prefixed SB or SCB).

Please note a dowel of sufficient length should be used to secure the finial through the pier cap into the pier.

(SB1) **PC1**

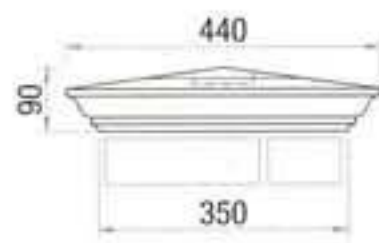

Weight: 24Kg

(SB11) **PC11**

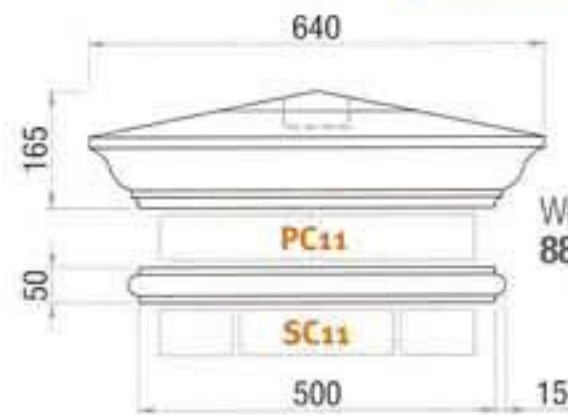

Weight: 88Kg

Weight: 28Kg

(SB21) **PC21**

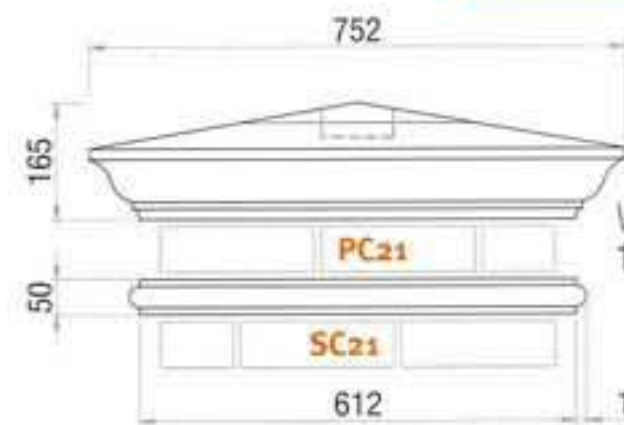

Weight: 125Kg

Weight: 42Kg

(SB31) **PC31**



Weight: 199Kg

Weight: 58Kg

(SB41) **PC41**



Weight: 15Kg

Weight: 5Kg

(SB51) **PC51**

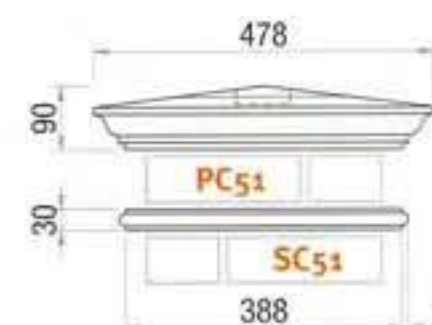

Weight: 29Kg

Weight: 10Kg

(SCB2) **PCP2**

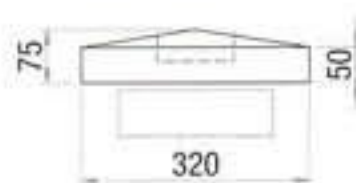

Weight: 13Kg

(SCB3) **PCP3**

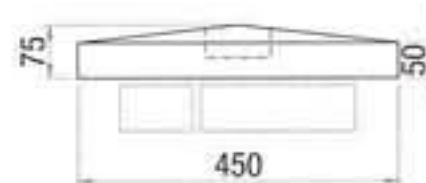

Weight: 25Kg

(SCB4) **PCP4**

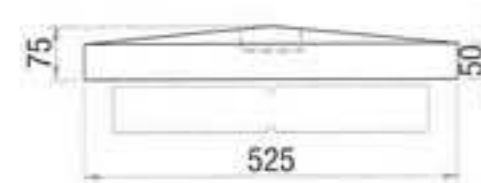

Weight: 34Kg

(SCB6) **PCP6**

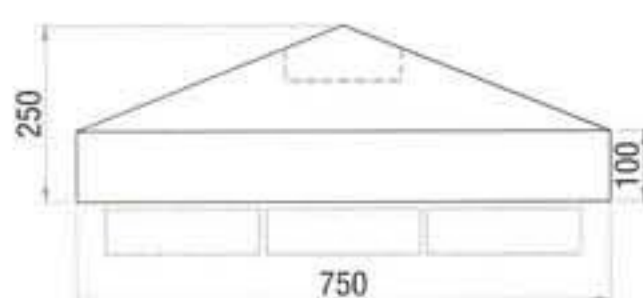

Weight: 180Kg

(SCB7) **PCP7**

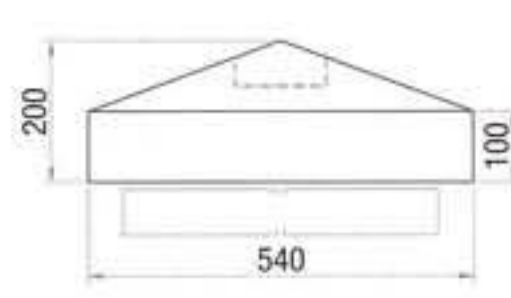

Weight: 83Kg

(SCB8) **PCP8**

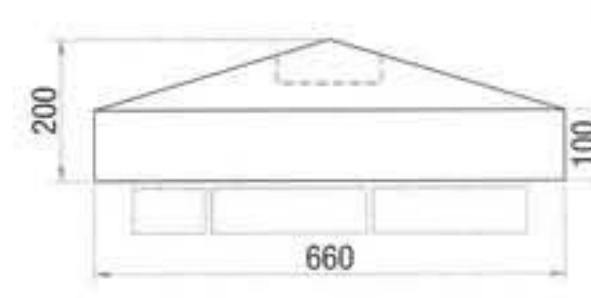

Weight: 123Kg



Pier Caps

Pier Caps can be manufactured either four times weathered to a point or with a square recess to locate a stone sphere or alternative finial. Dotted lines on the drawing indicates aperture, please specify which is required when ordering (pier caps with aperture are prefixed SB).

Please note a dowel of sufficient length should be used to secure the finial through the pier cap into the pier.

PC2 (SB2)

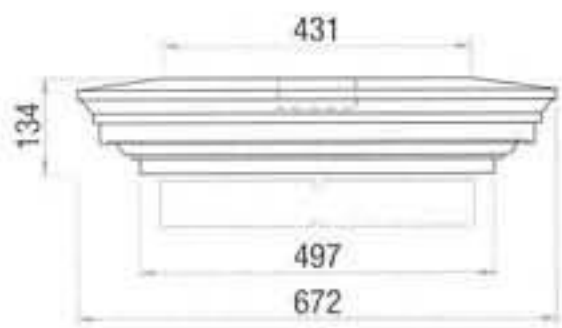

Weight: 99Kg

PC3 (SB3)

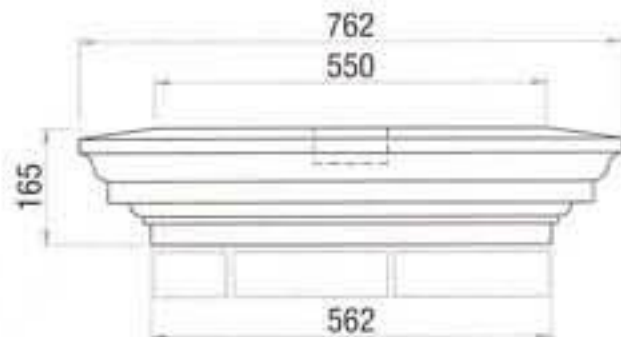

Weight: 155Kg

PC10 (SB10)

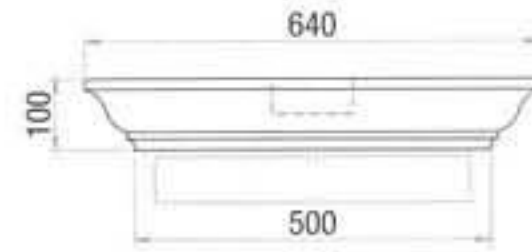

Weight: 70Kg

PC20 (SB20)

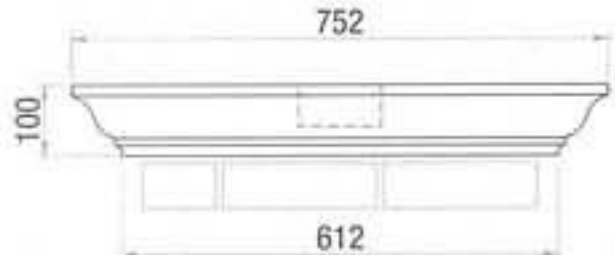

Weight: 100Kg

PC30 (SB30)

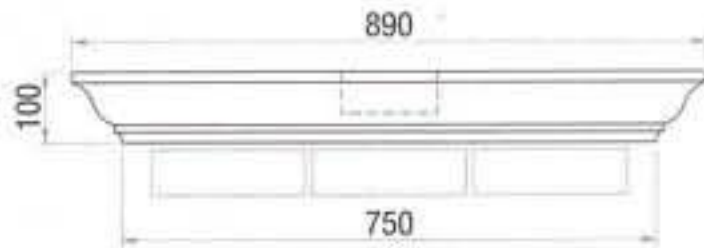

Weight: 143Kg

PC40 (SB40)

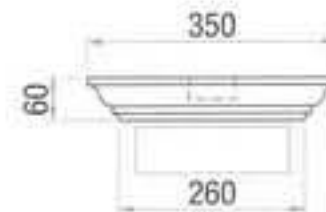

Weight: 12Kg

PC50 (SB50)

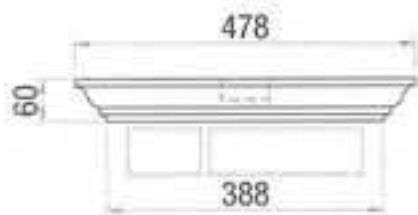

Weight: 24Kg

PL100C (SB100)

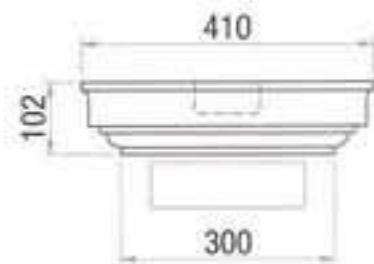

Weight: 30Kg

PL125C (SB125)

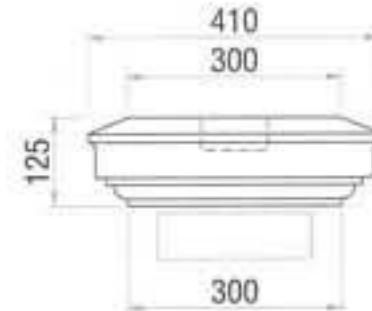

Weight: 36Kg

PD200C (SB200)

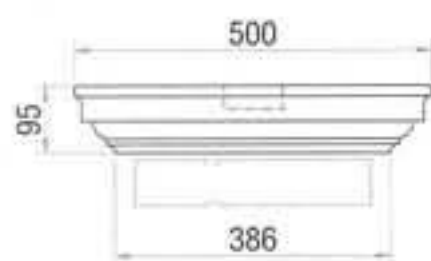

Weight: 40Kg

PD300C (SB300)

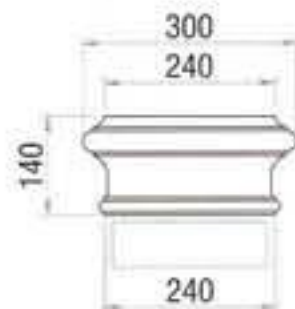

Weight: 19Kg

Pier Caps



PC4

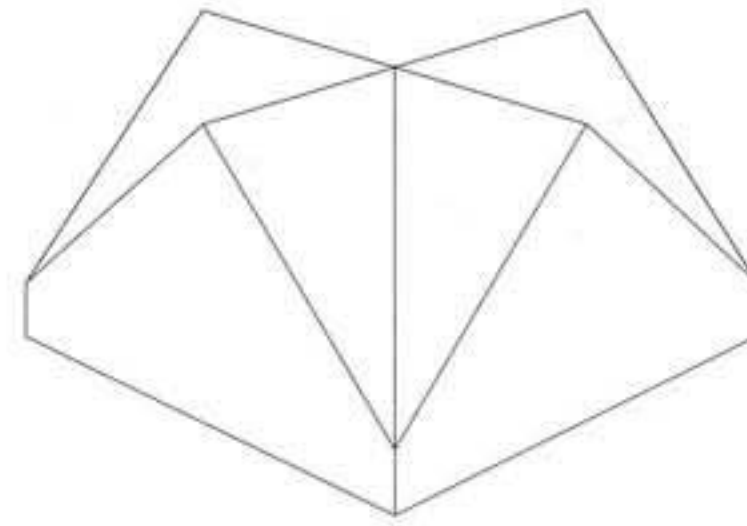
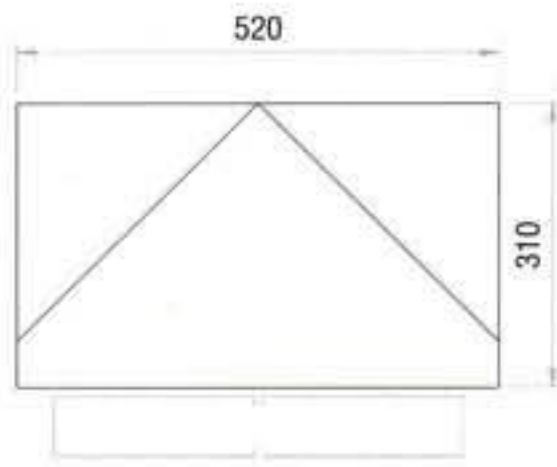

Weight: 128Kg

PC5

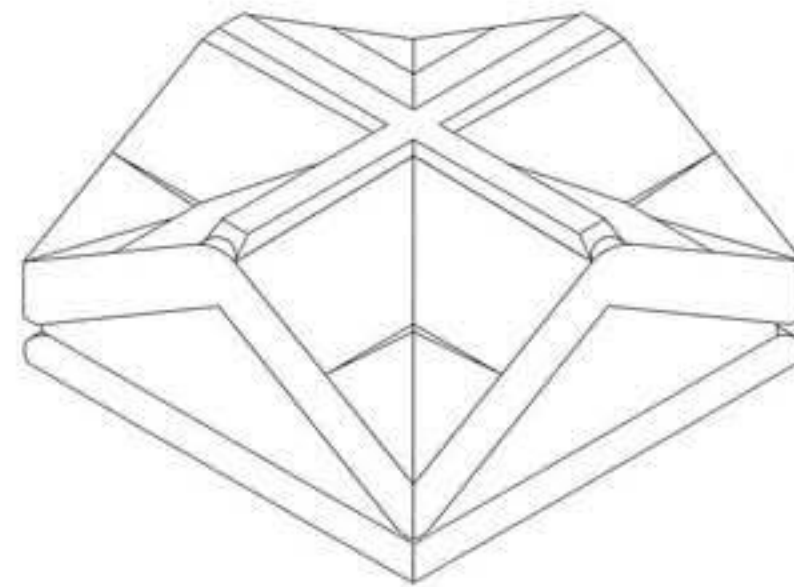
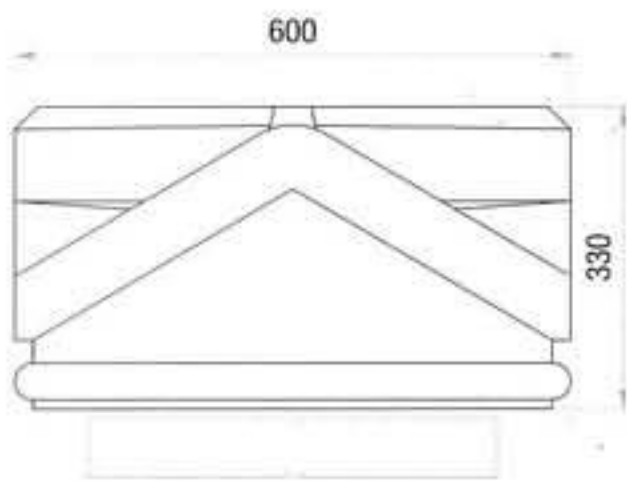

Weight: 190Kg

OC1

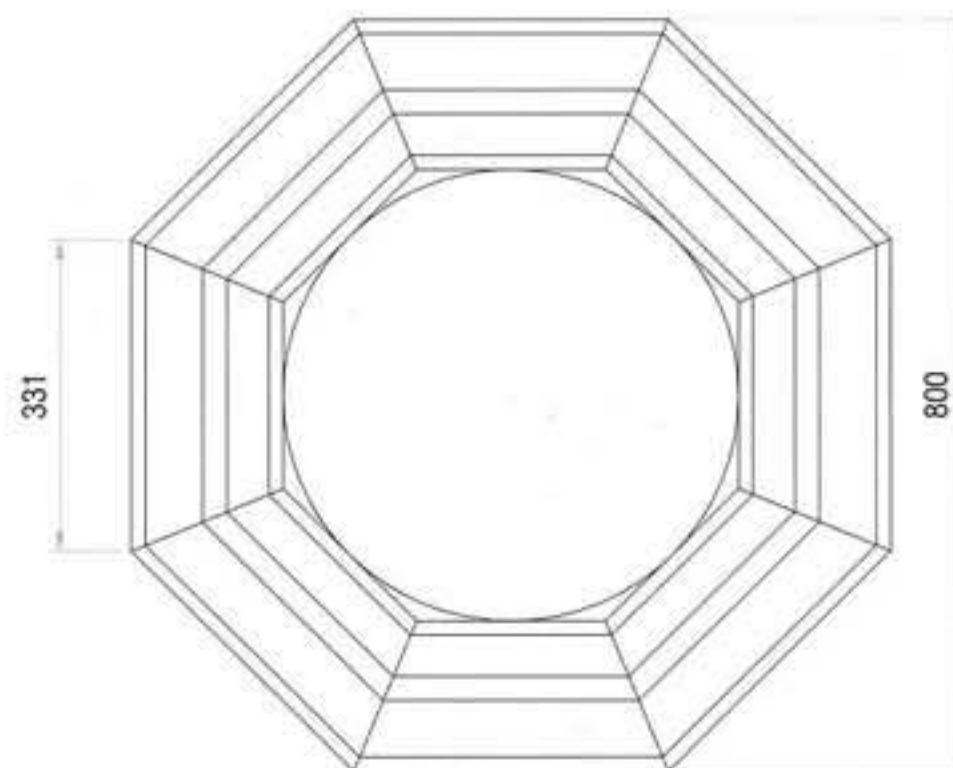
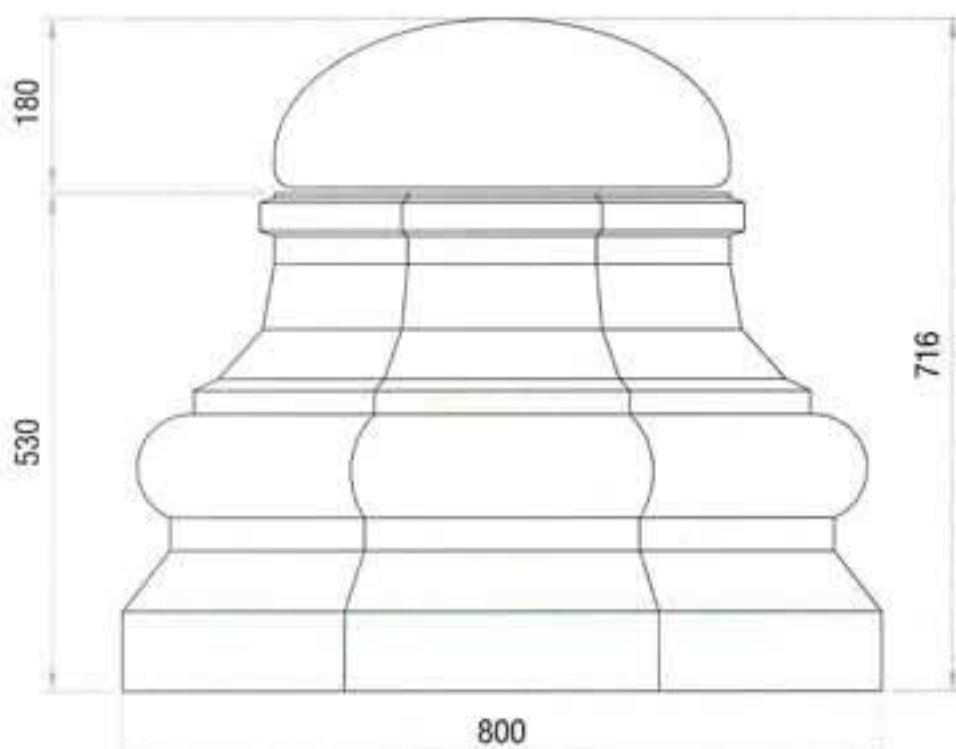

Weight: 340Kg



Gate Piers

GP1

GP2

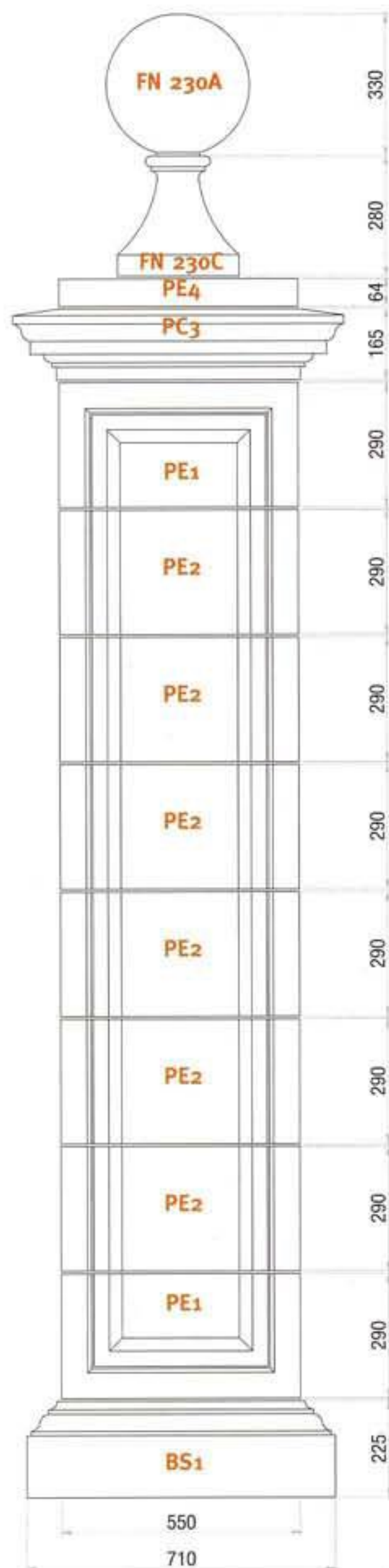

Total Weight: 1216Kg



Total Weight: 440Kg

Balustrades



Balustrading is available in three heights and with a choice of a weathered or flat rail and pier cap. To order please specify which style and height is required and then select the style of baluster required. The 535 baluster matches either the 105 or 100 pier, 610 baluster matches a 115 or 110 pier and the 725 baluster matches the 120 or 125 pier. 45° piers and under copings are also available. Rails are supplied in standard lengths, on site cutting is to be undertaken by the installation contractor.

Rails and Piers can be manufactured to allow a steel restraint to be inserted to provide additional stability, please specify on ordering if this is required.

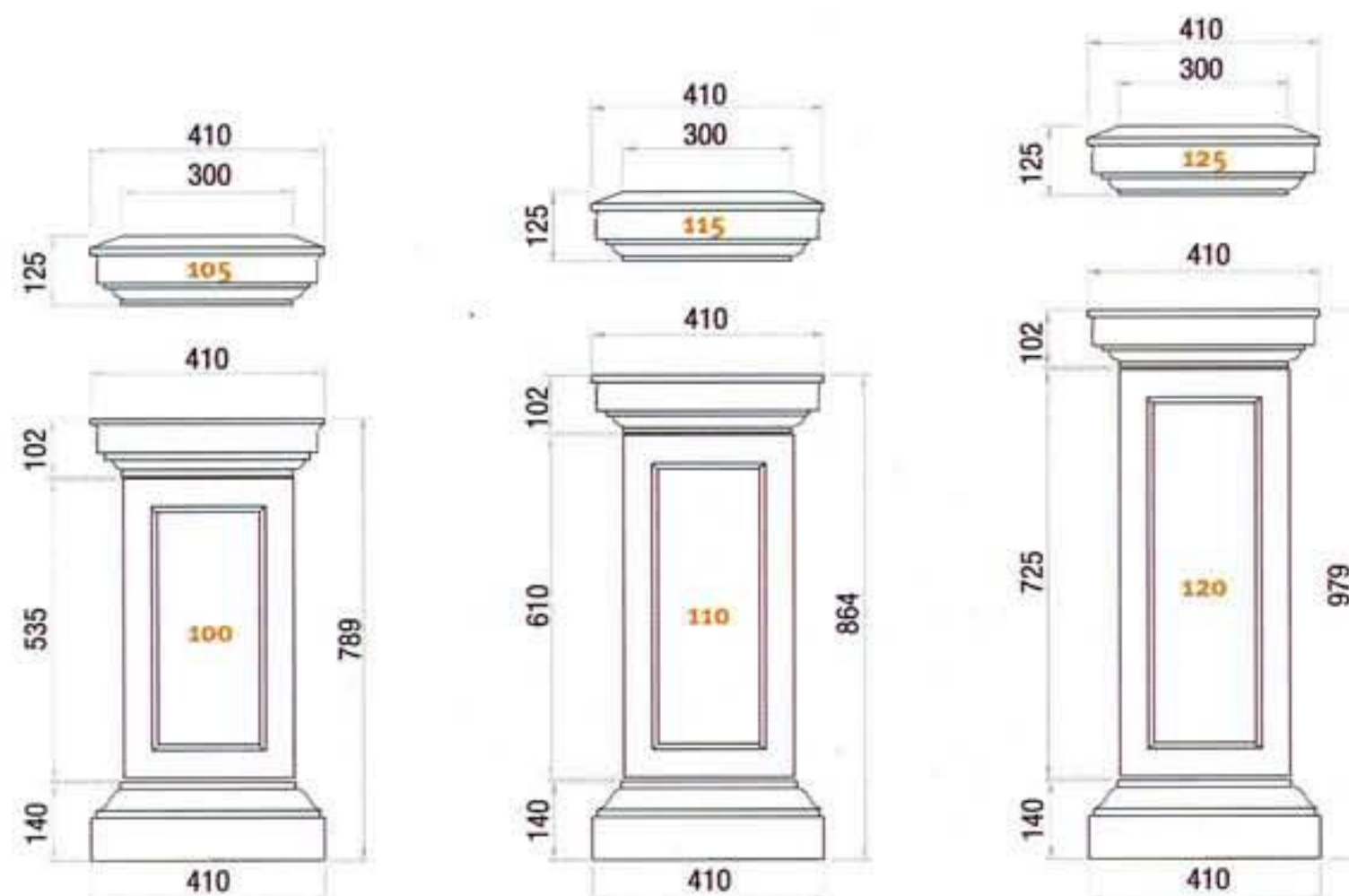
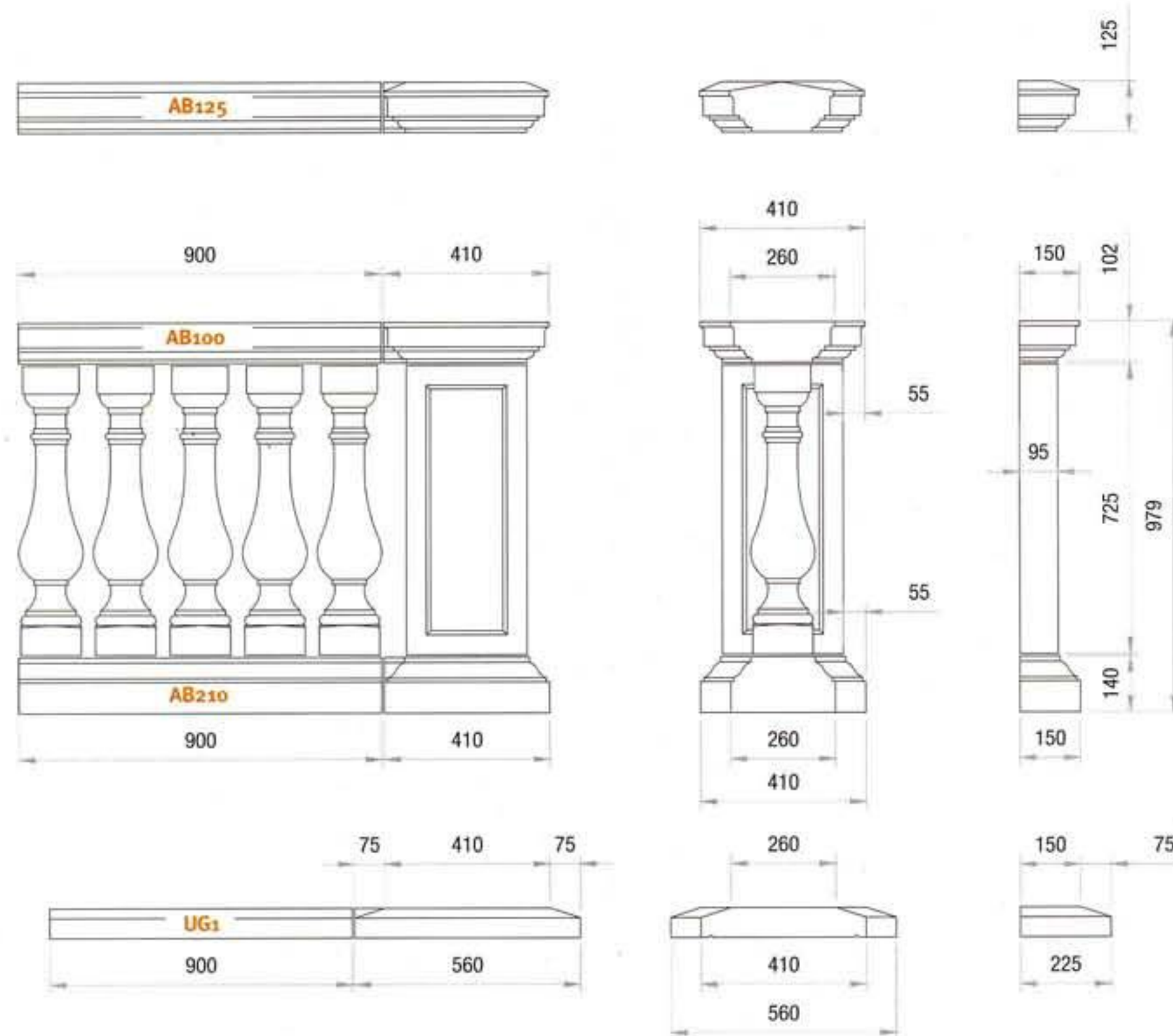



Pier Layouts

Central and side run-in piers are available. To order please select the required height and style of pier from the previous page and insert the relevant number code where the XXX is shown in brackets. For example, to order a flat topped pier that has a central run-in on one side for a 535 baluster you would order an AC100A.

Run-in positions available

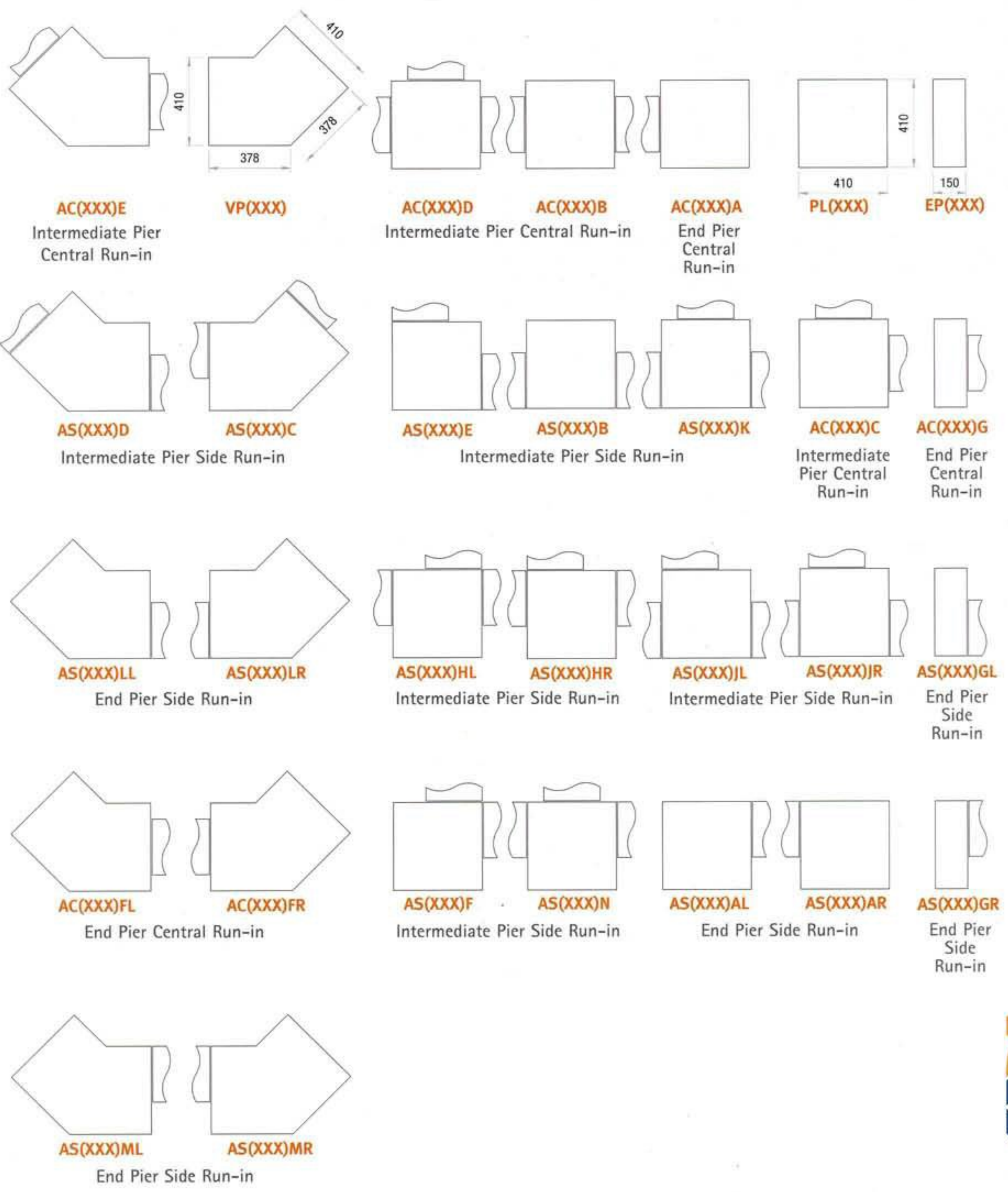

Under Copings

Under copings to match pier layouts are available. Straight under copings are supplied in standard lengths, on site cutting is to be undertaken by the installation contractor.



Straight Under Coping

UG1

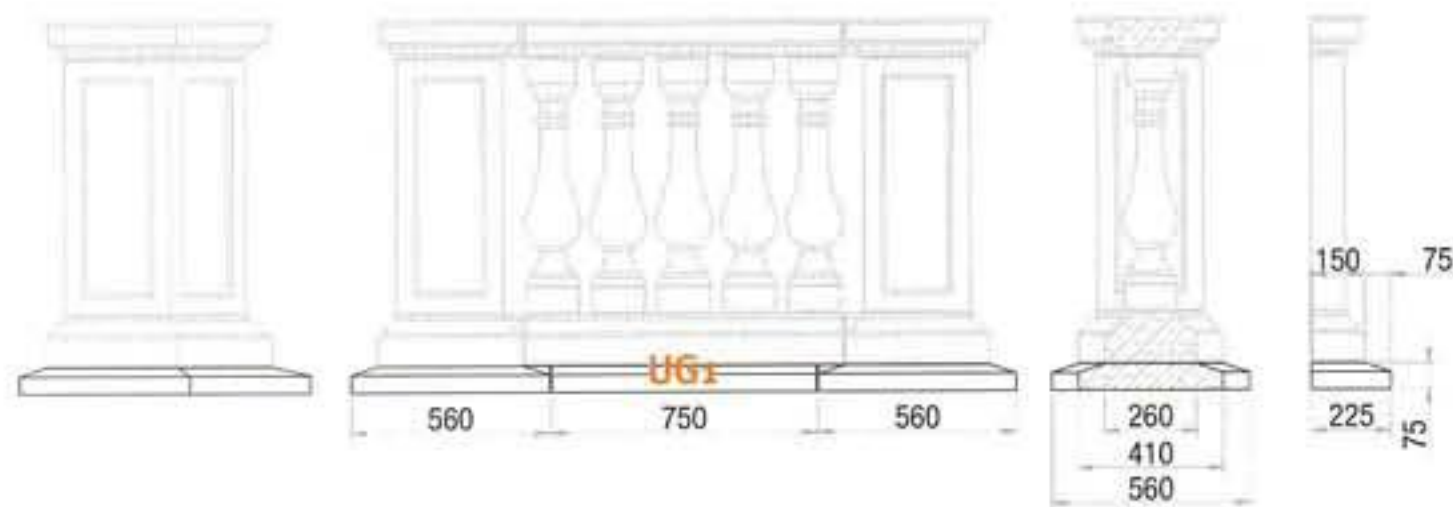

Run-in positions available

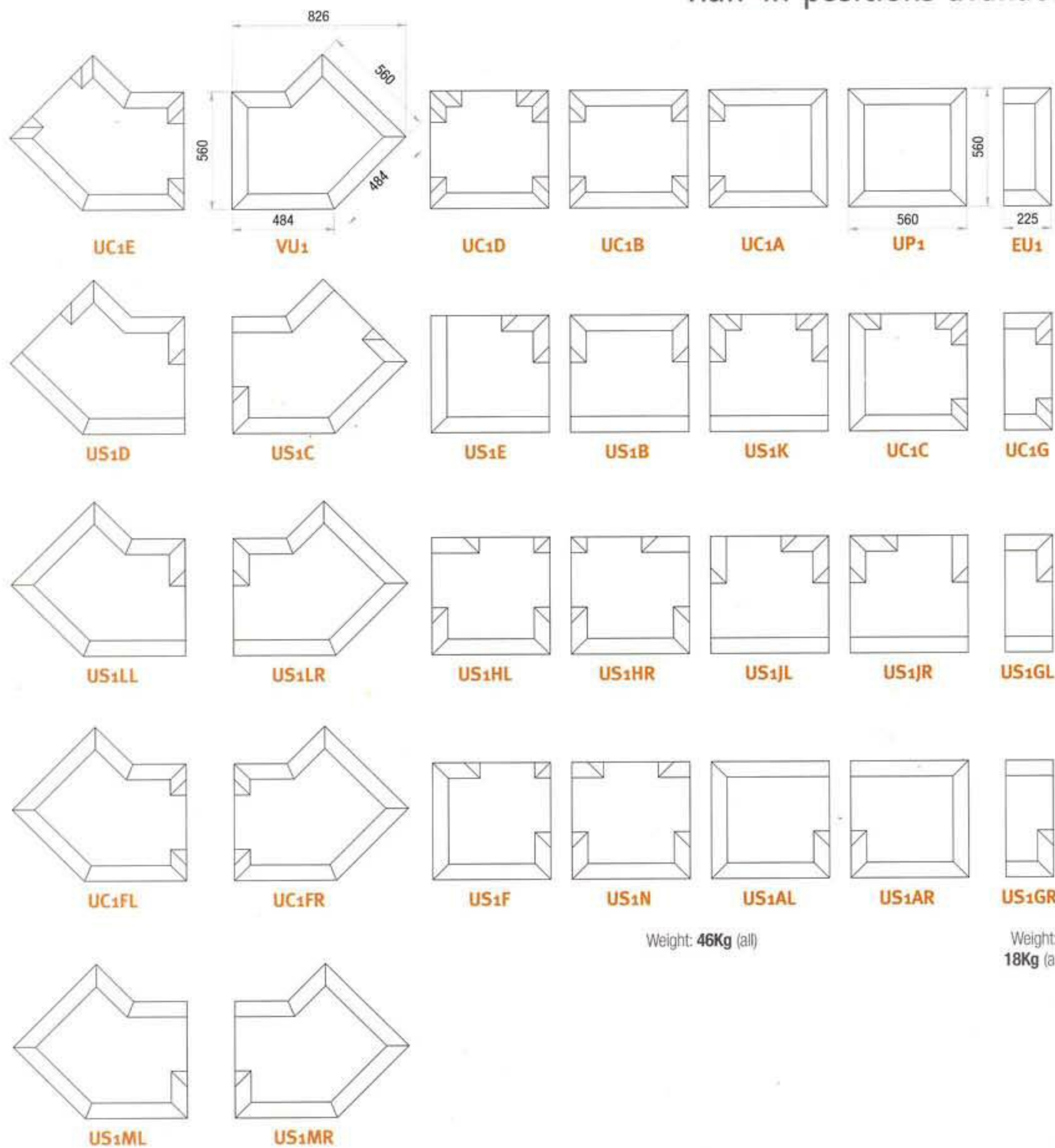

Weight: 46Kg (all)

Weight: 18Kg (all)

Weight: 60Kg (all)



Balusters

The AB837 is specifically designed to be cut on the rake (by the installation contractor) for use in ramped balustrading. All balusters are supplied complete with stainless steel dowels for fixing into rails and plinths.

Where balustrading is used on balconies and/or elevated patio areas, current building regulations dictate that the overall height of the balustrade from finished floor level to the top of the rail should be 1100mm (min). The AB725 is suitable for this use.

AB

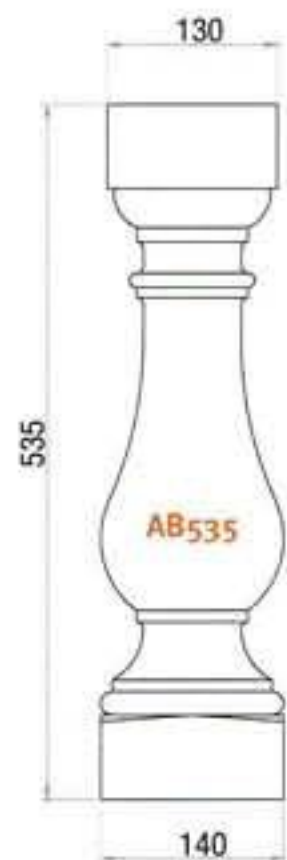

Weight: 11Kg

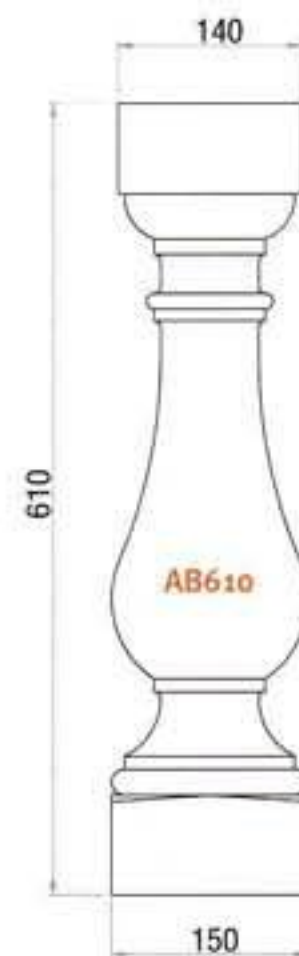

Weight: 13Kg

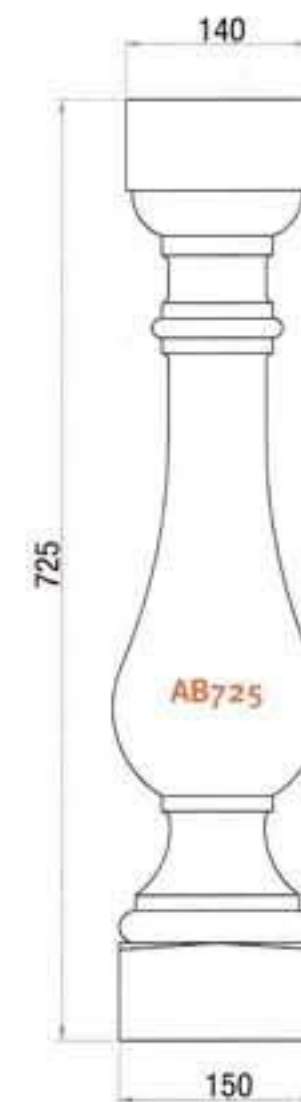

Weight: 16Kg

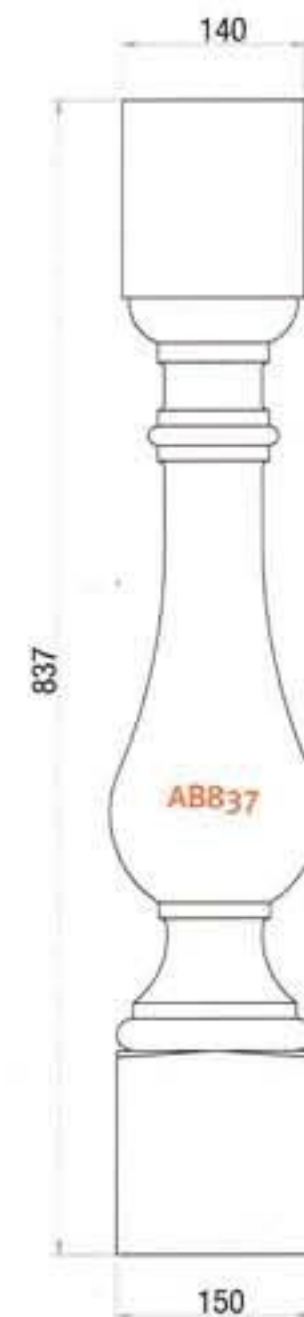

Weight: 21Kg

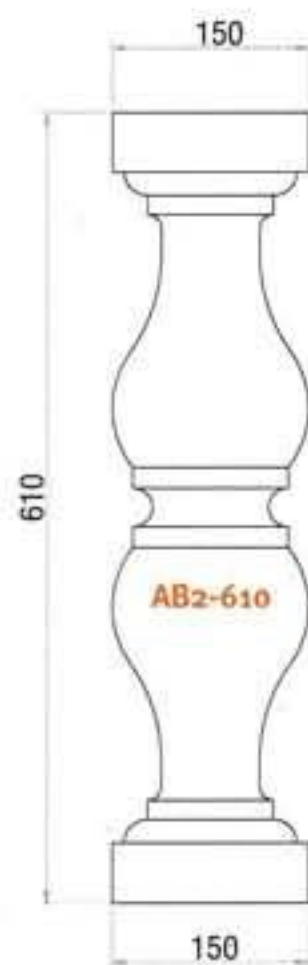

Weight: 13Kg

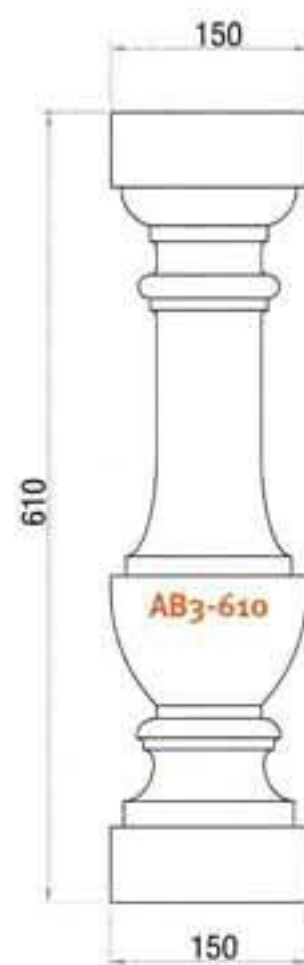

Square in section throughout
Weight: 17Kg

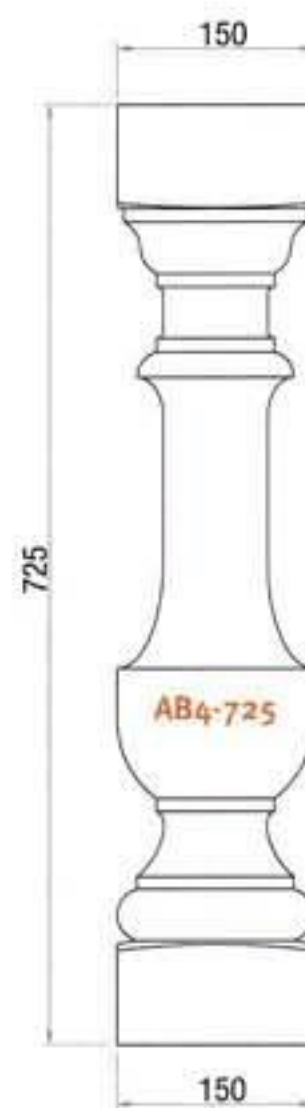

Weight: 16Kg

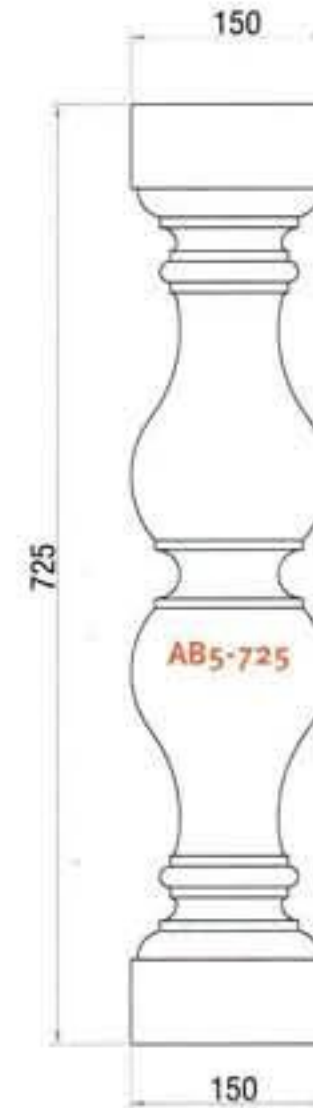

Weight: 16Kg



Weight: 16Kg

Parapet Screening



PP1

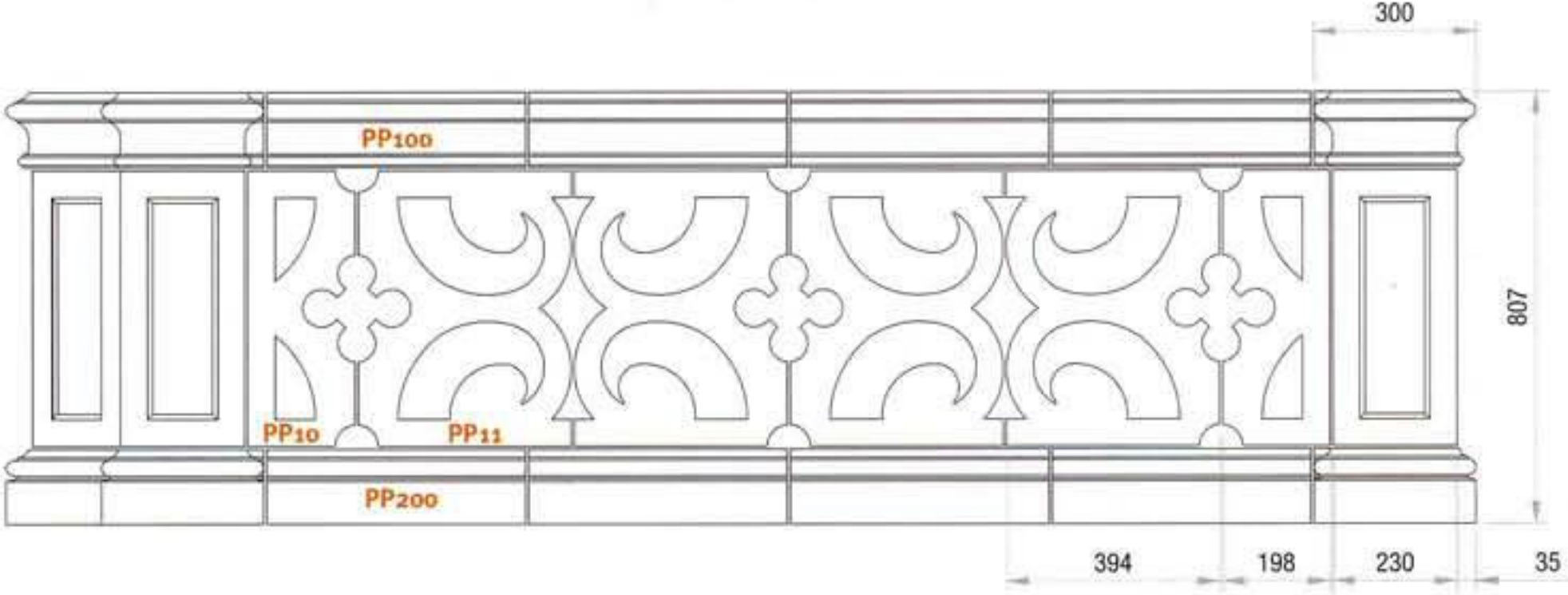

PP2

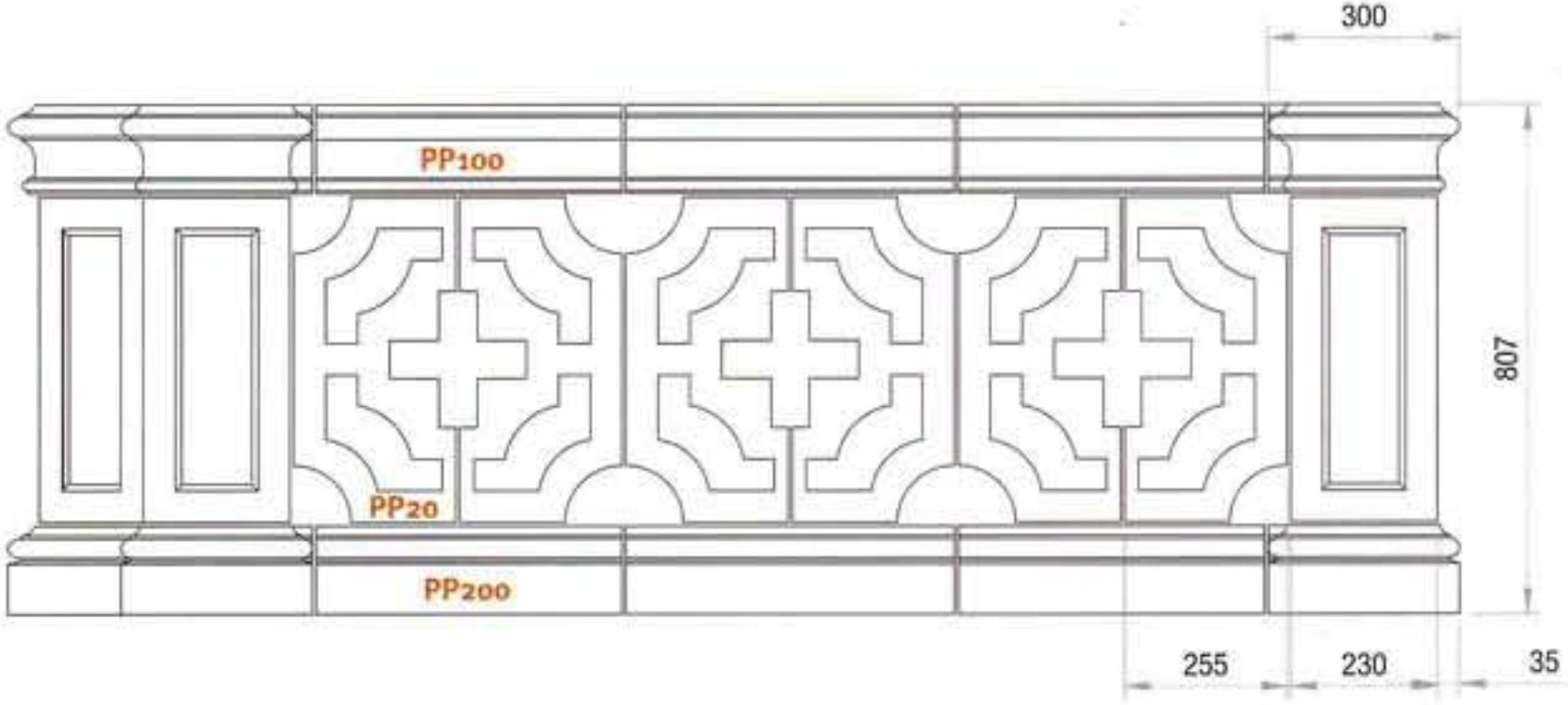

PP3

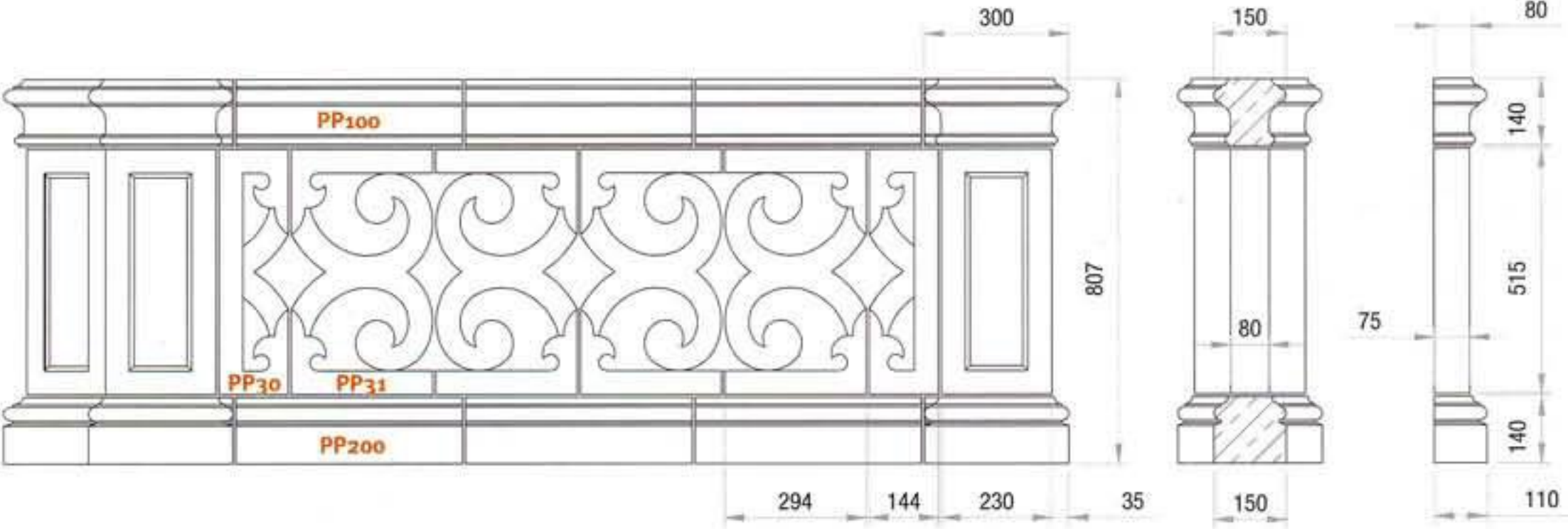



Parapet Pier Layouts

PP106 45° Central Pier

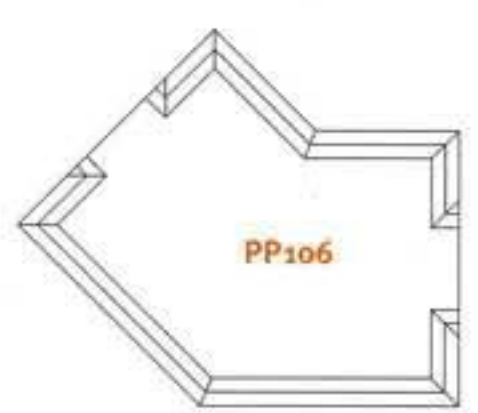

Weight: 147Kg Intermediate Pier Central Run-in

PP105L 45° Left Run-in

PP105R 45° Right Run-in

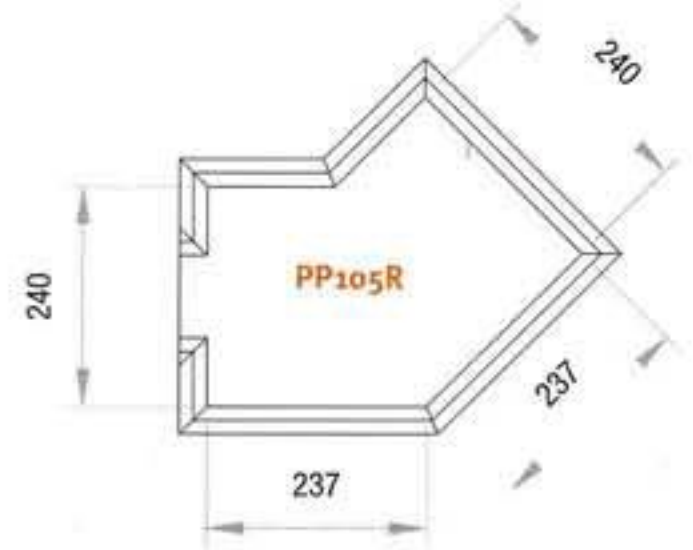
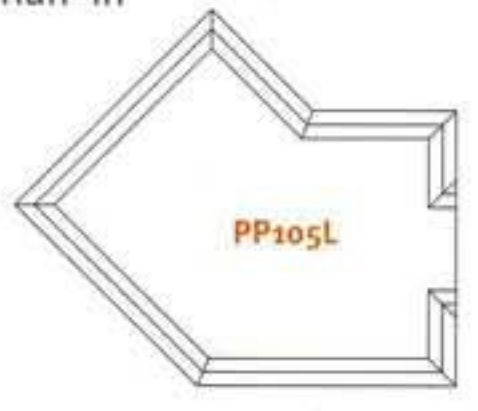

Weight: 147Kg End Pier Central Run-in

PP101

PP102

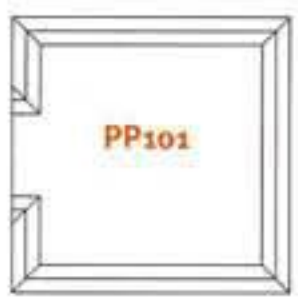

Weight: 95Kg End Pier Central Run-in Intermediate Pier Central Run-in

PP103

PP104

EP301

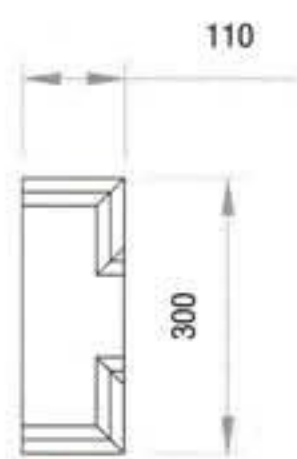
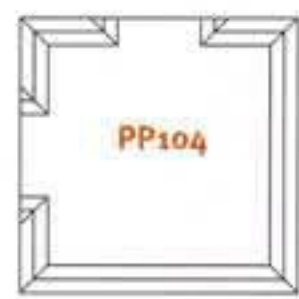

Weight: 95Kg Intermediate Pier Central Run-in End Pier Central Run-in

EP301 Weight: 32Kg



Gable Features



GV1

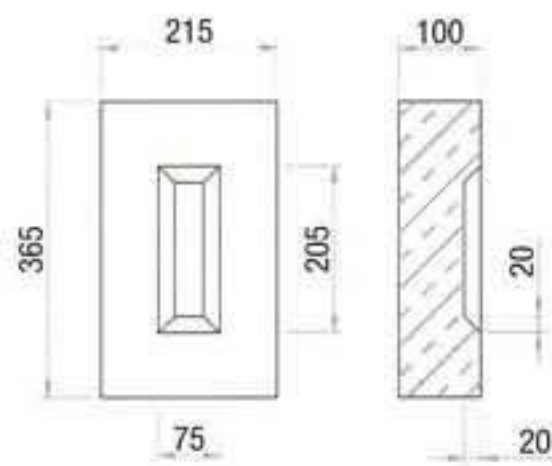

Weight: 17Kg

GV2

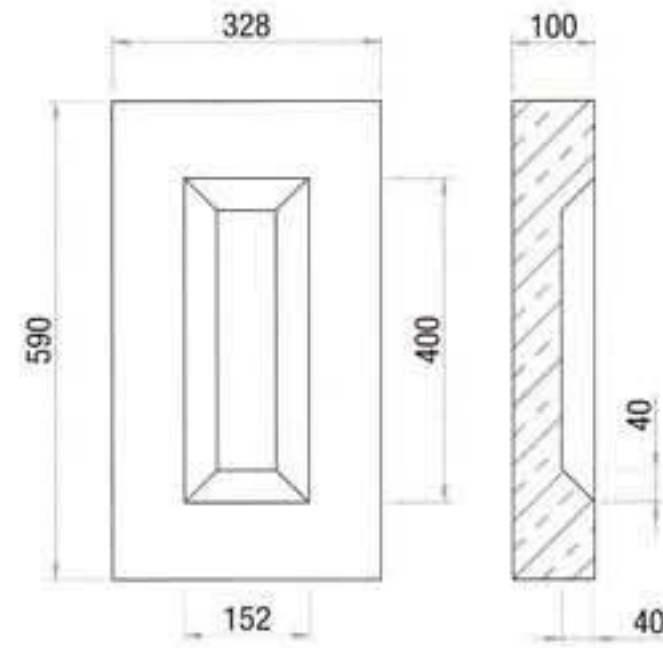

Weight: 36Kg

GV3

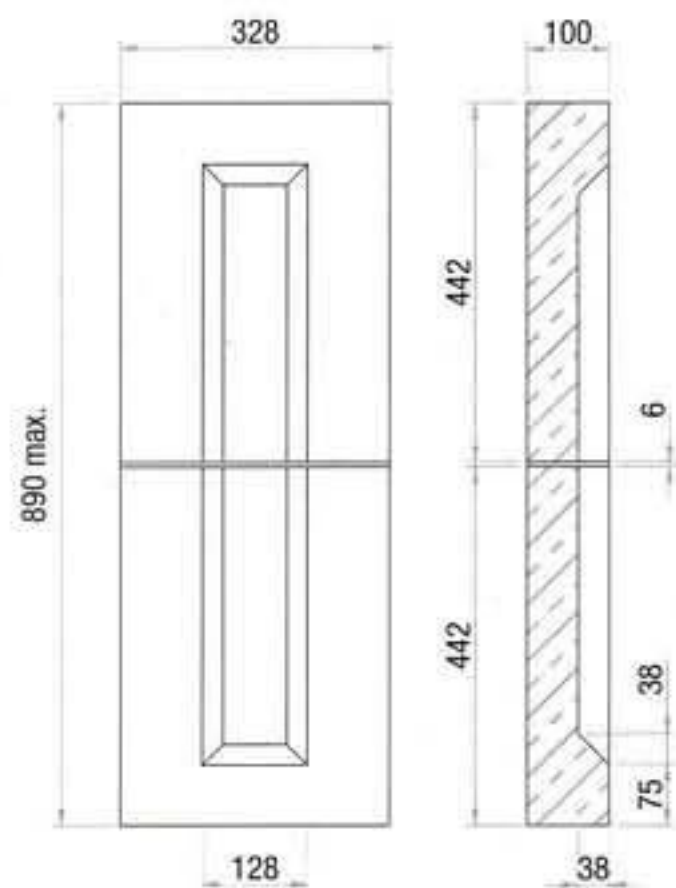

GV4

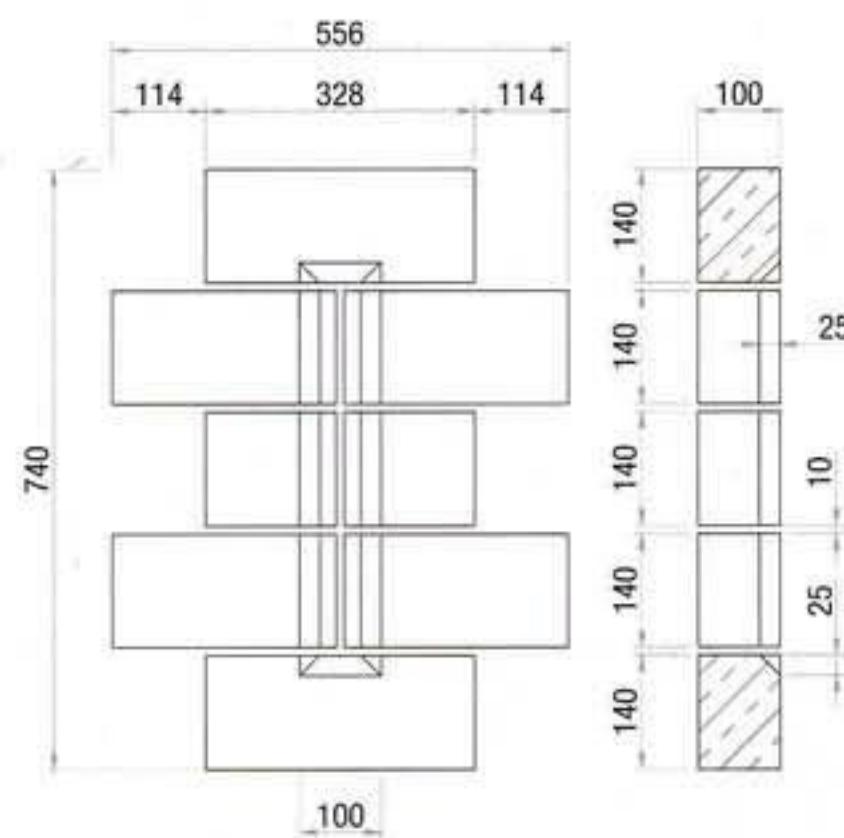

Weight: 60Kg



Obelisks

OB1

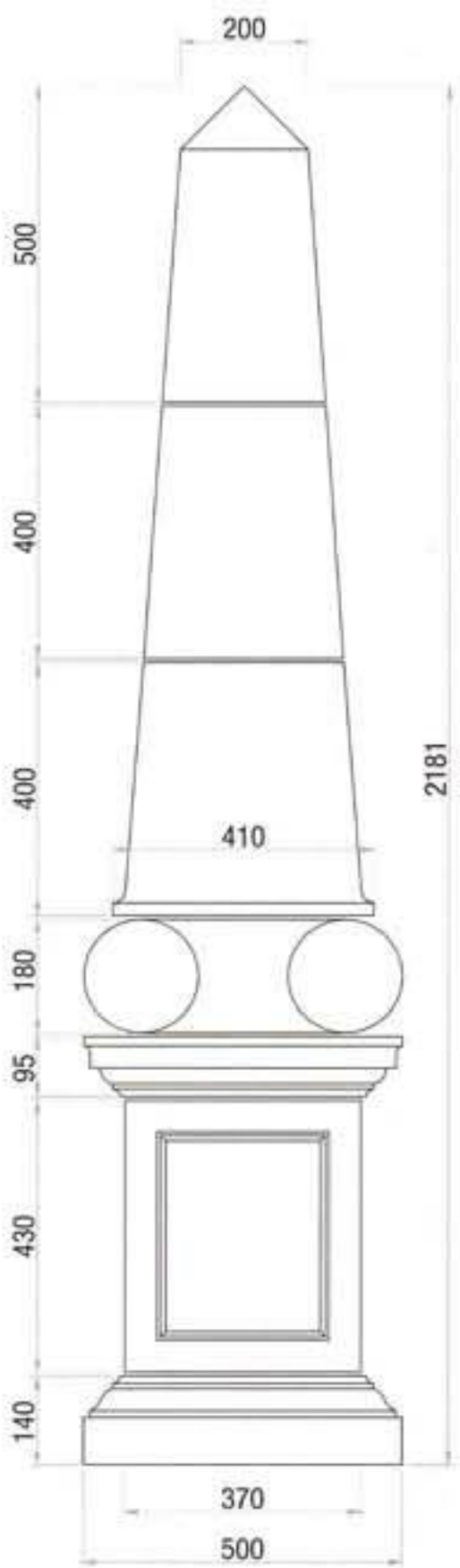

Total Weight: **460Kg**

OB2

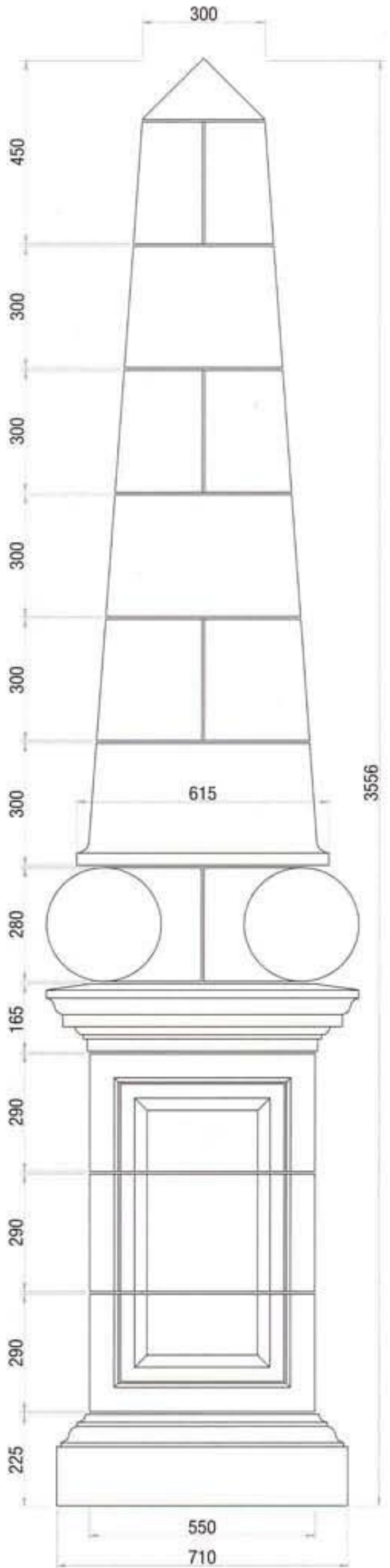

Total Weight: **1600Kg**

Chimney Caps



These units are designed for insitu flaunching with concrete and the stones should be tied into the surrounding brickwork and/or concrete flaunching by means of mechanical ties.

Please specify dimensions 'A' and 'B' when ordering.

X90R

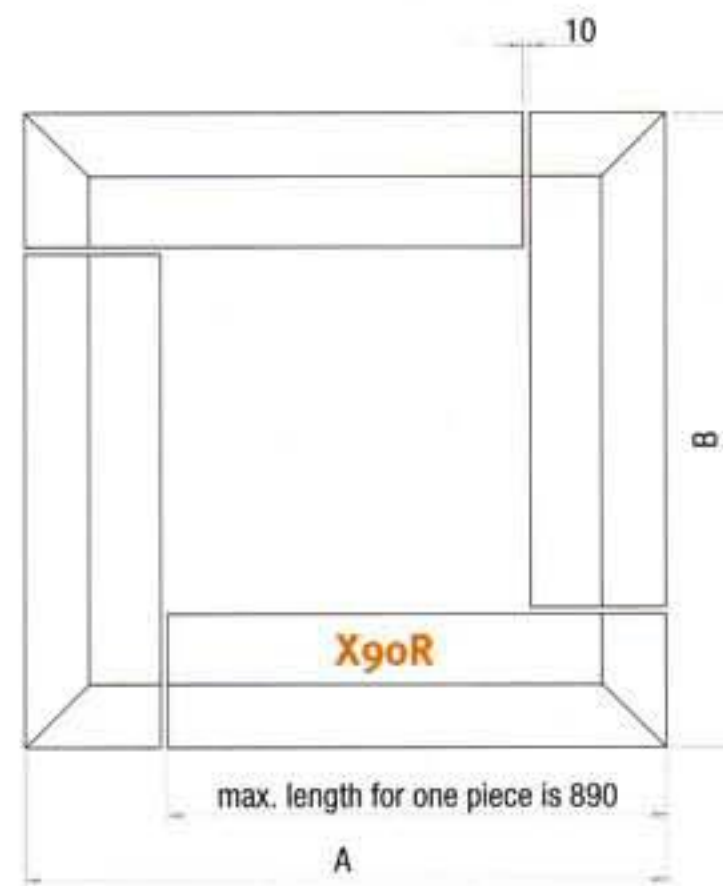

SC

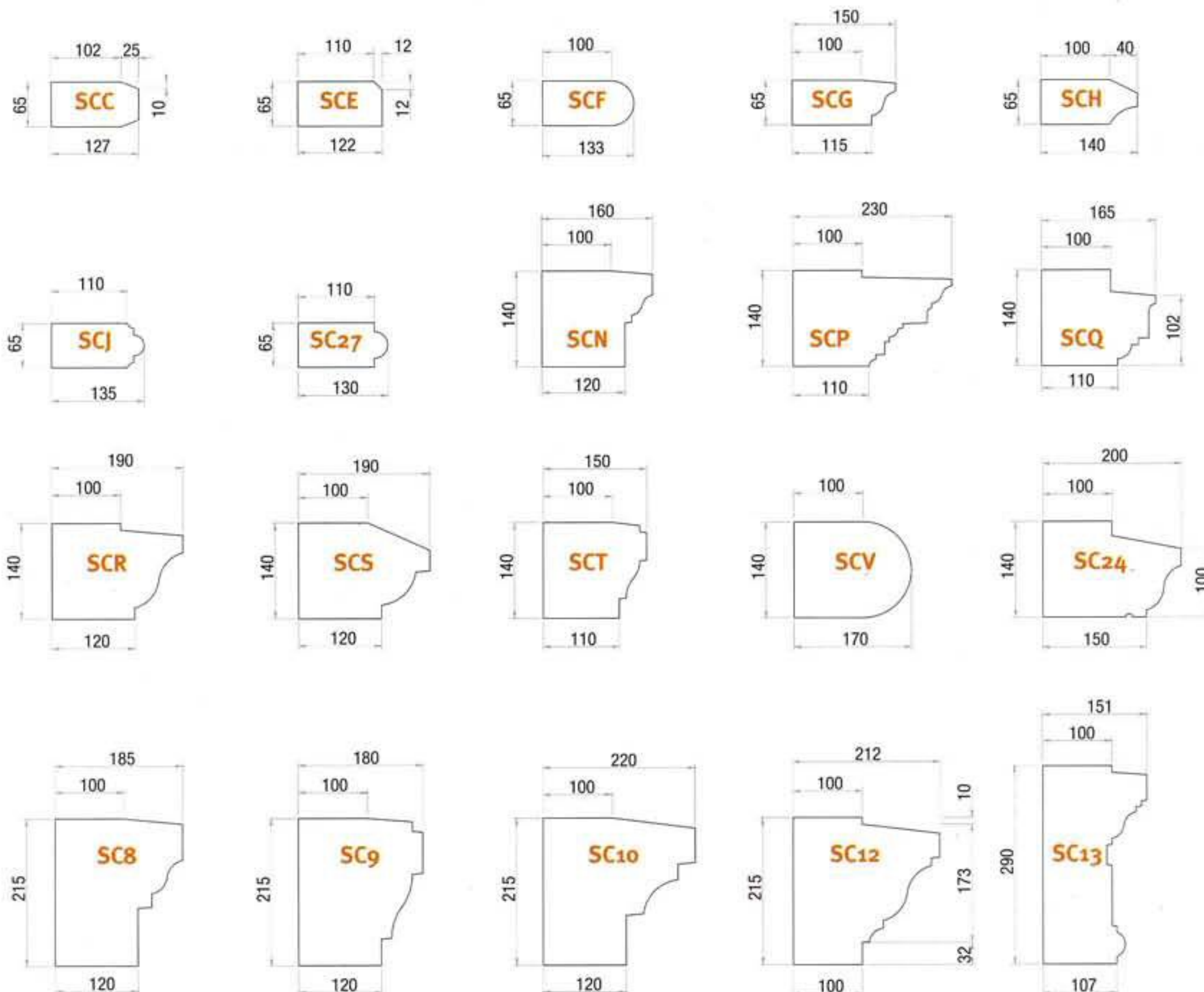



Pier & Pedestal Bases

Weights are shown in Kg/m. Please specify dimensions 'A' and 'B' when ordering.

X90L

X90R

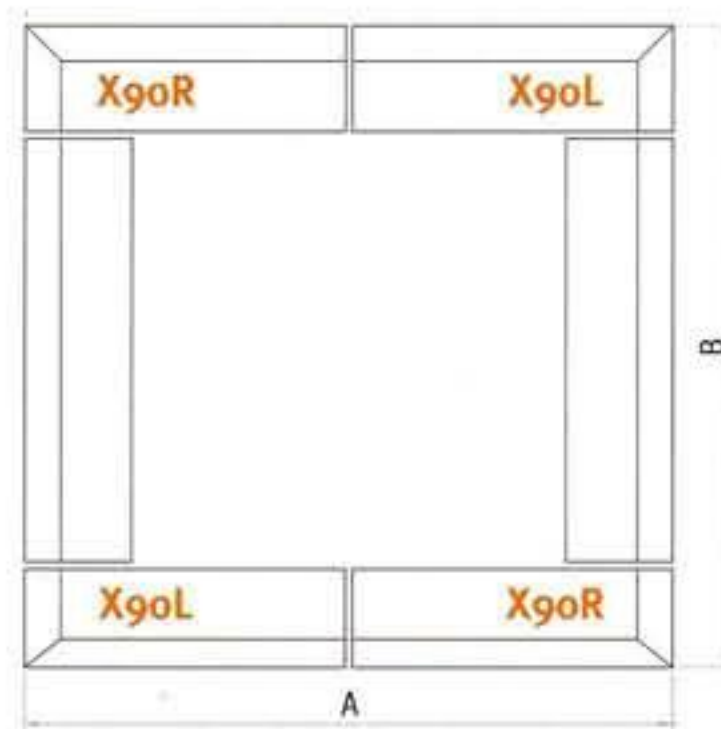

SC34

SCZ

SC29

SC30

SC32



PB300B

PL100B

PB200B

BS1

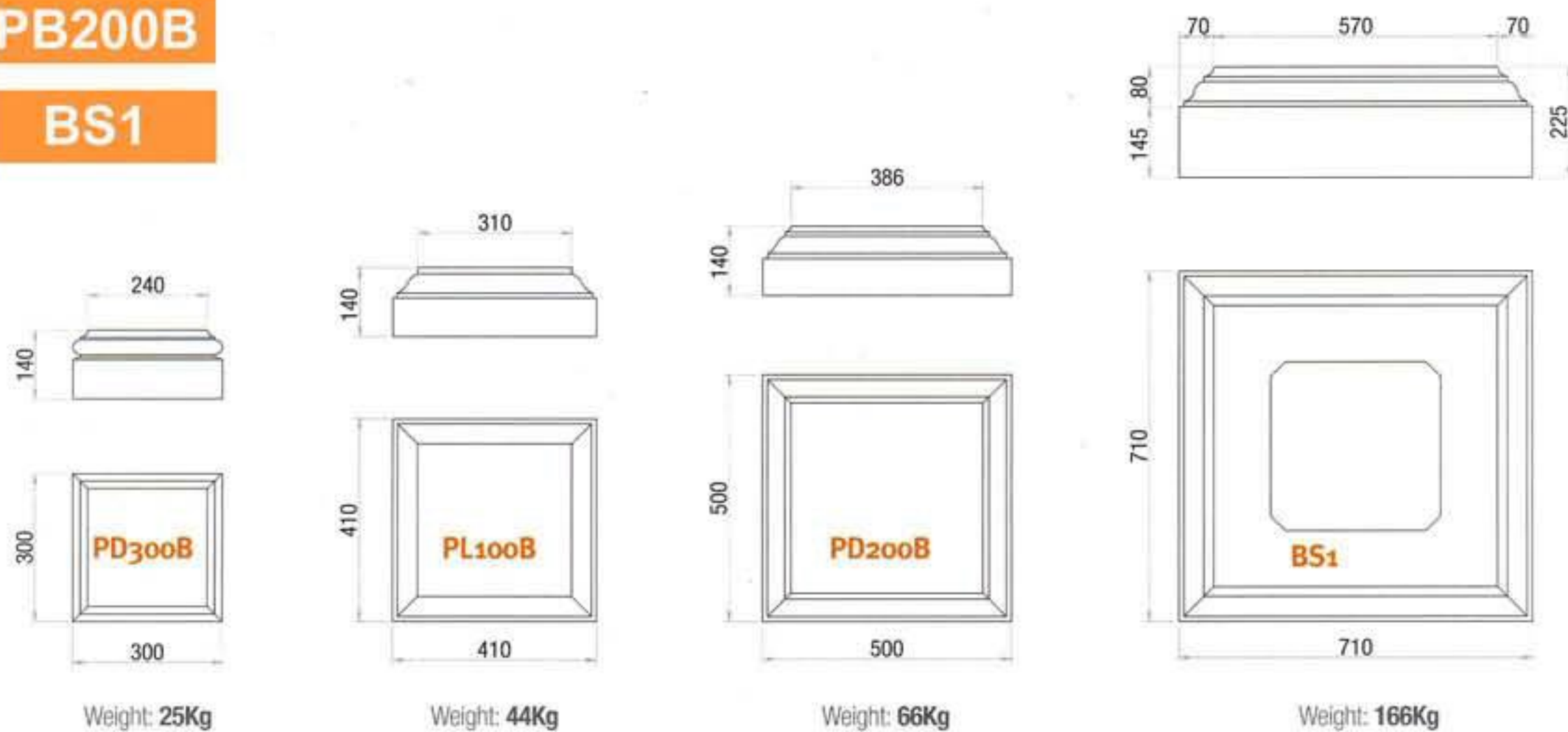

Pedestals & Plinths



PL

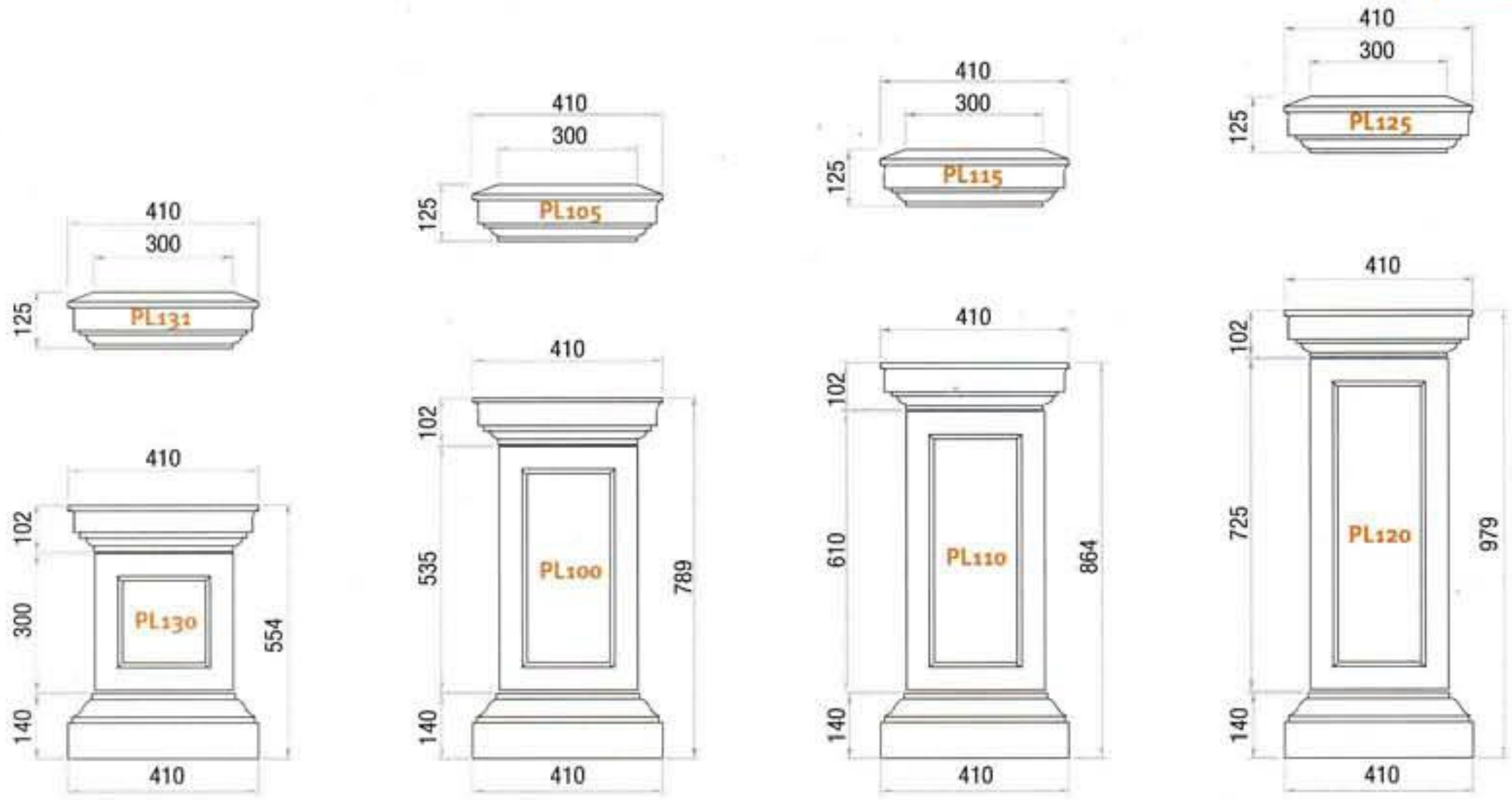

PL131 Total Weight: 113Kg
PL130 Total Weight: 107Kg
PL105 Total Weight: 132Kg
PL100 Total Weight: 127Kg
PL115 Total Weight: 141Kg
PL110 Total Weight: 135Kg
PL125 Total Weight: 152Kg
PL120 Total Weight: 147Kg

VP

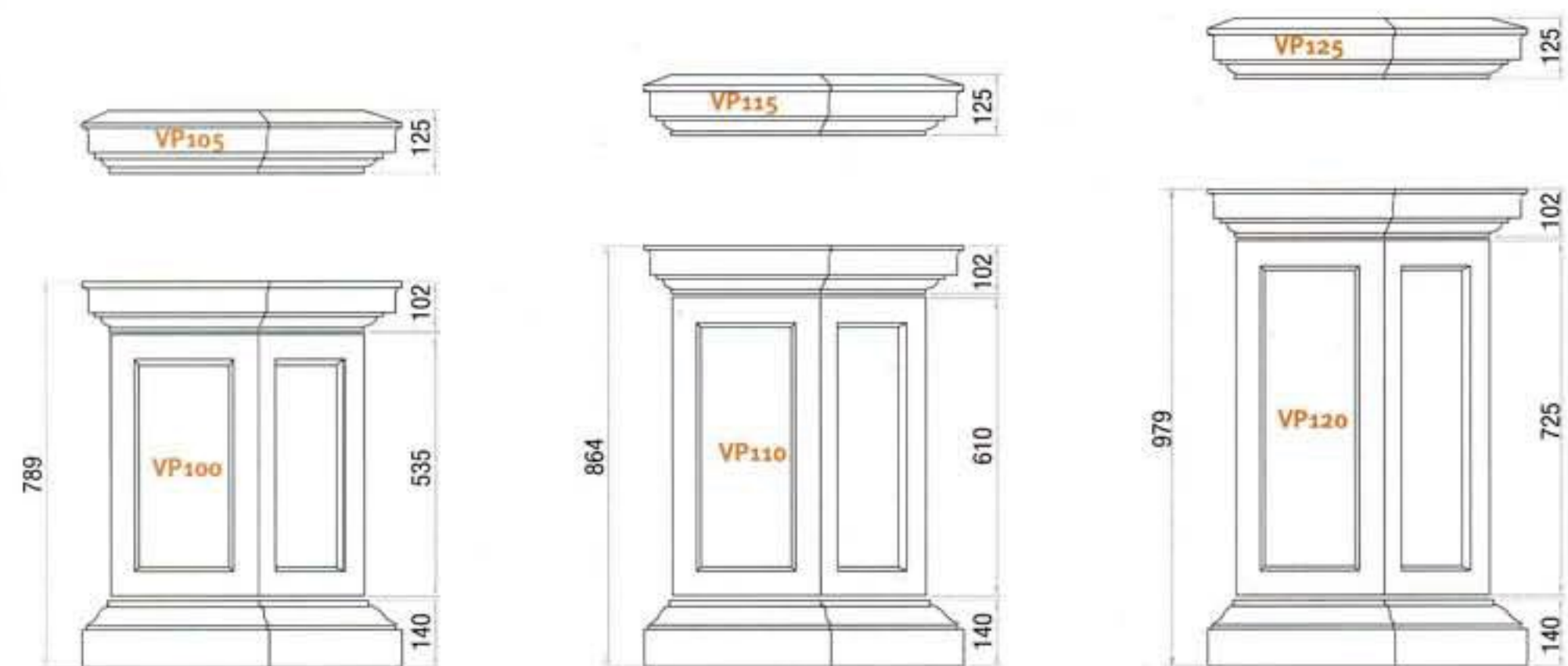

VP105 Total Weight: 210Kg
VP100 Total Weight: 200Kg
VP115 Total Weight: 225Kg
VP110 Total Weight: 215Kg
VP125 Total Weight: 245Kg
VP120 Total Weight: 235Kg

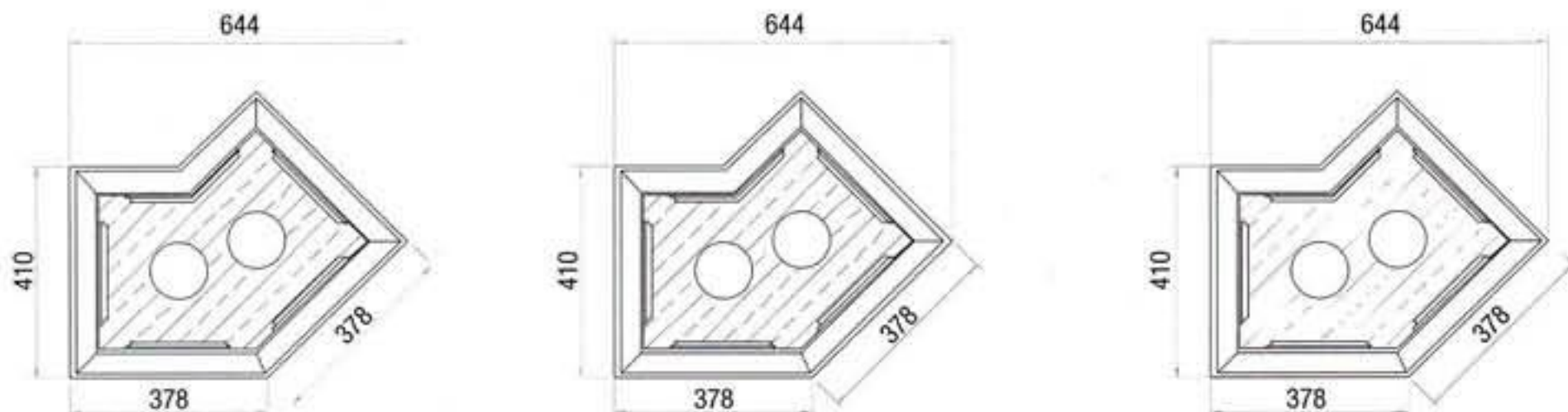

Pedestals & Plinths



PD300

Weight: 95Kg

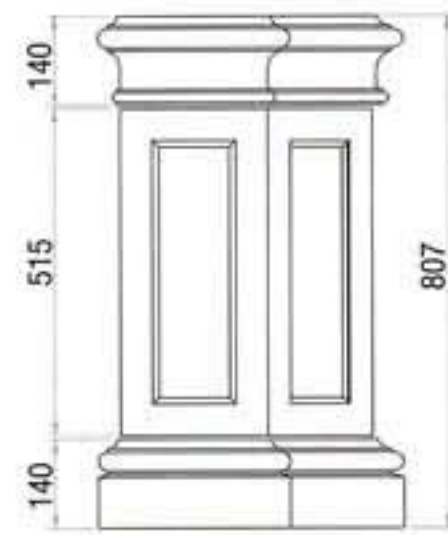

PD100

Weight: 45Kg

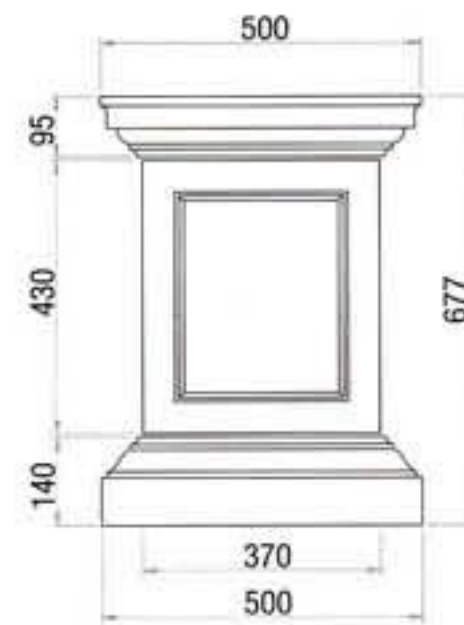

PD200

Weight: 180Kg

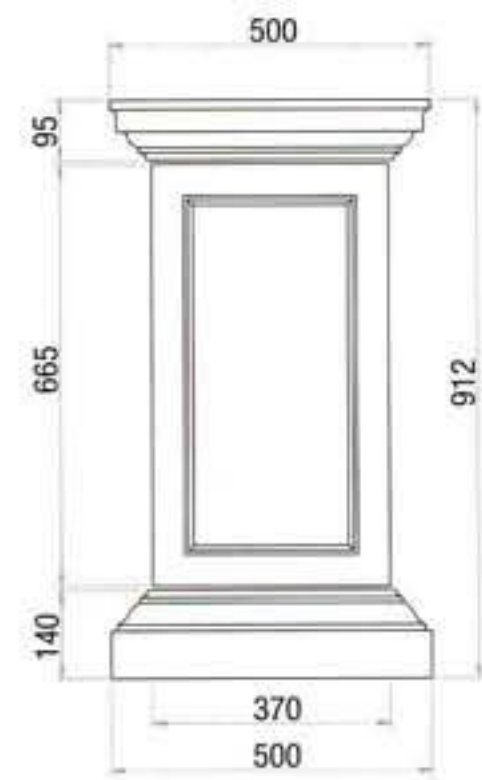

PD210

Weight: 225Kg

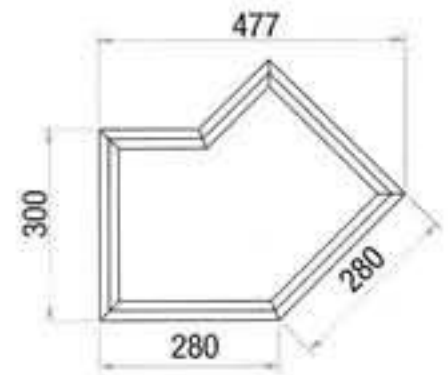

VP300

Weight: 147Kg

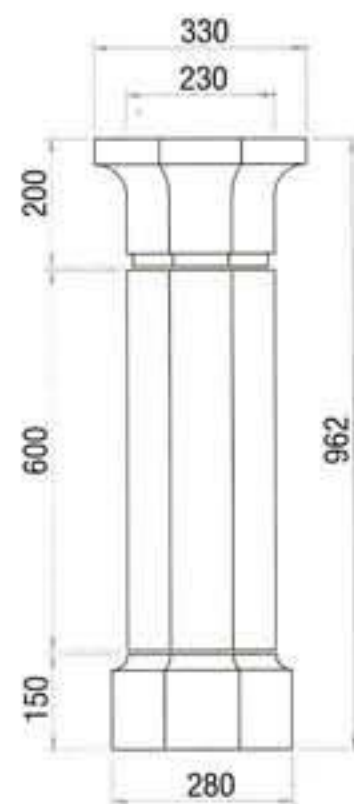

PD400

Weight: 88Kg

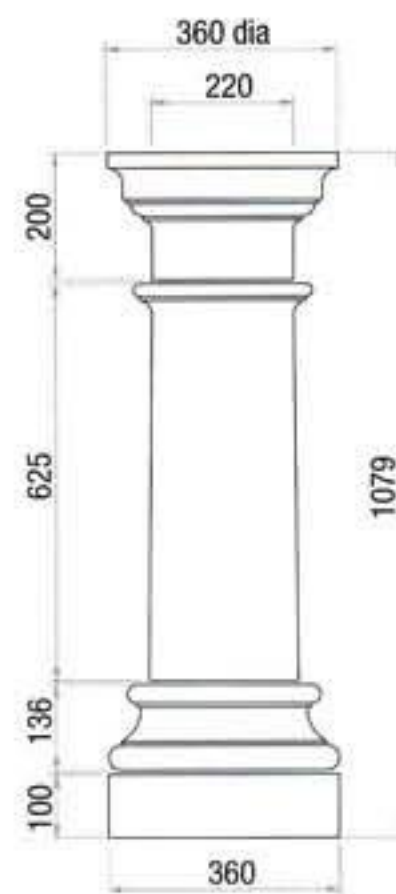

PD500

Weight: 122Kg

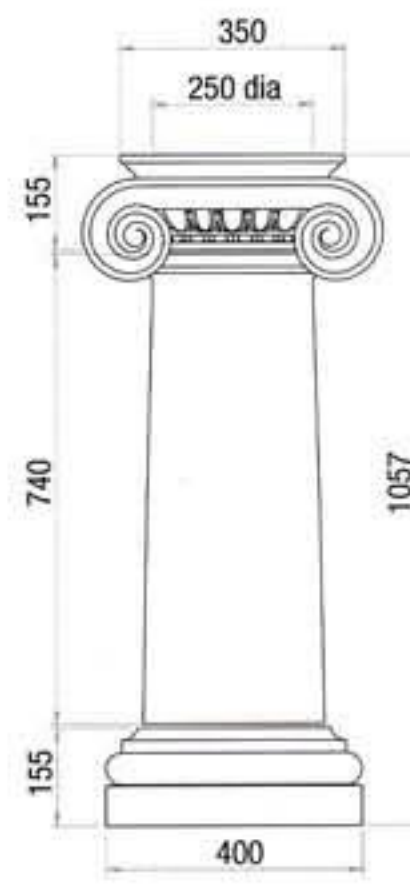

PD600

Weight: 165Kg

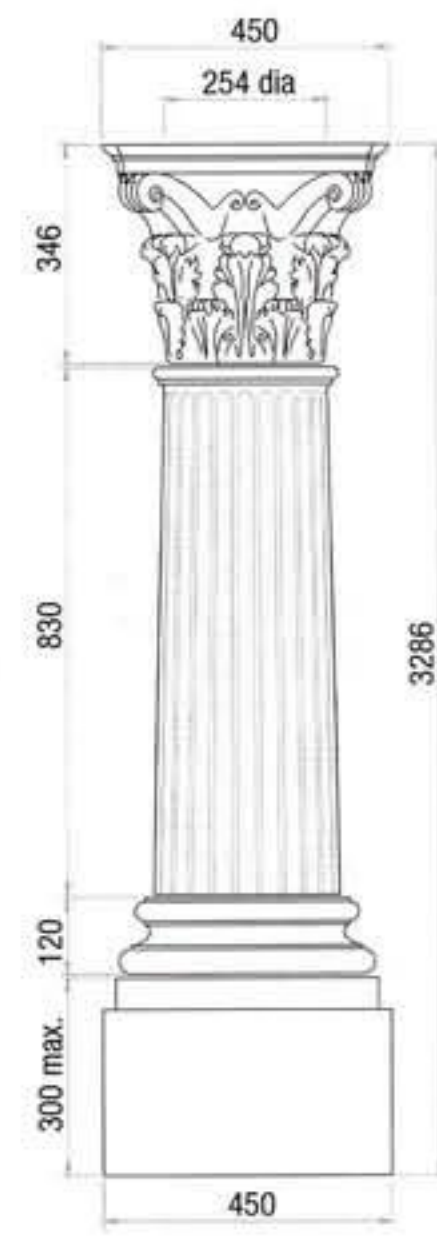

PD700

Weight: 300Kg

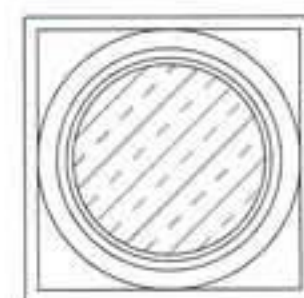
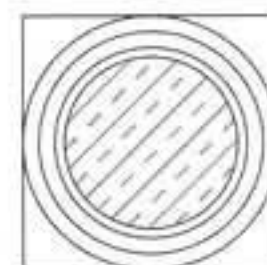
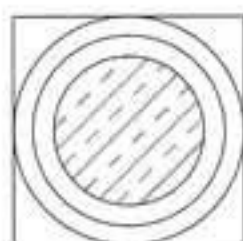

Finials

Please note a dowel of sufficient length should be used to secure the finial through the pier cap into the pier.

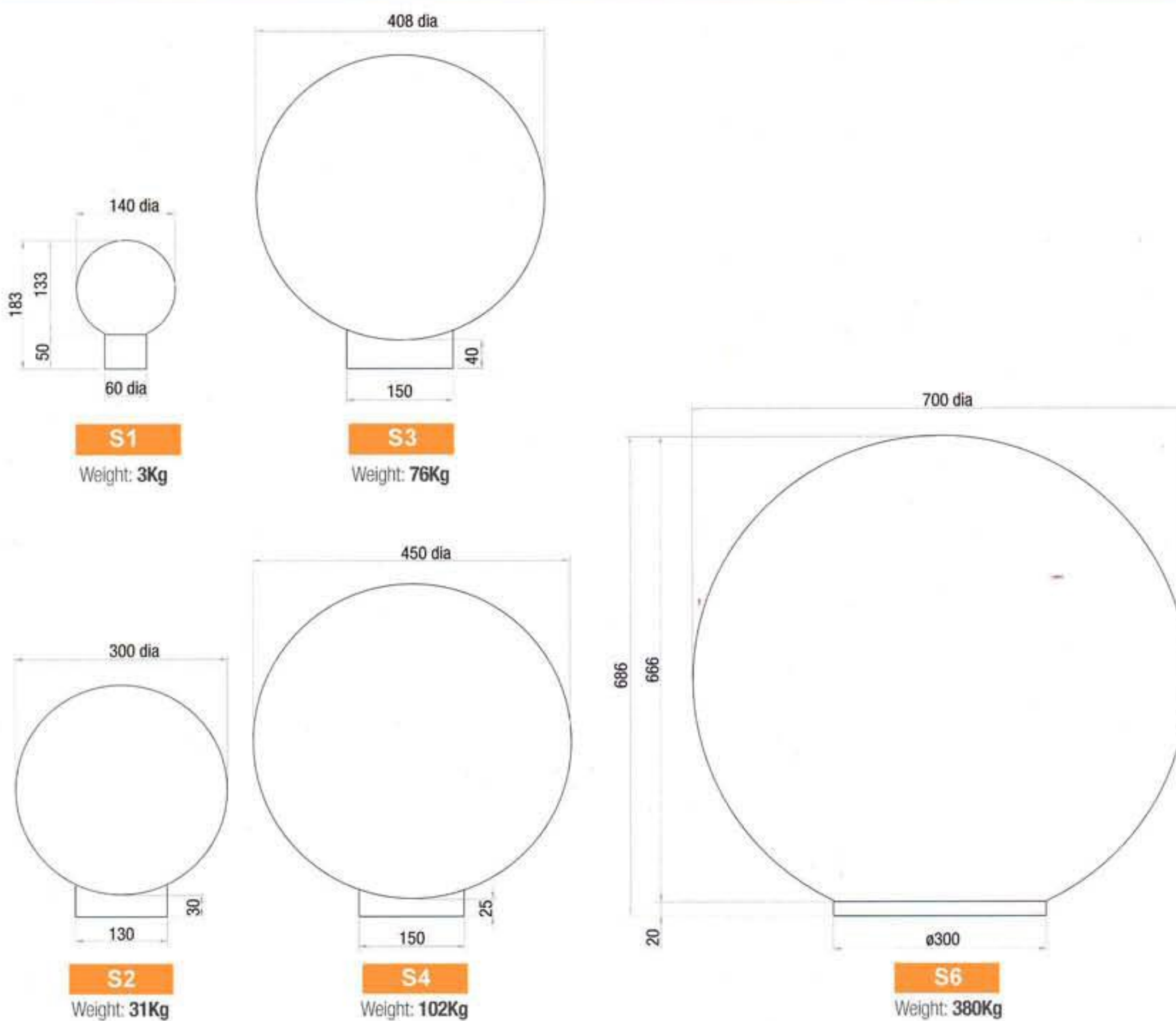
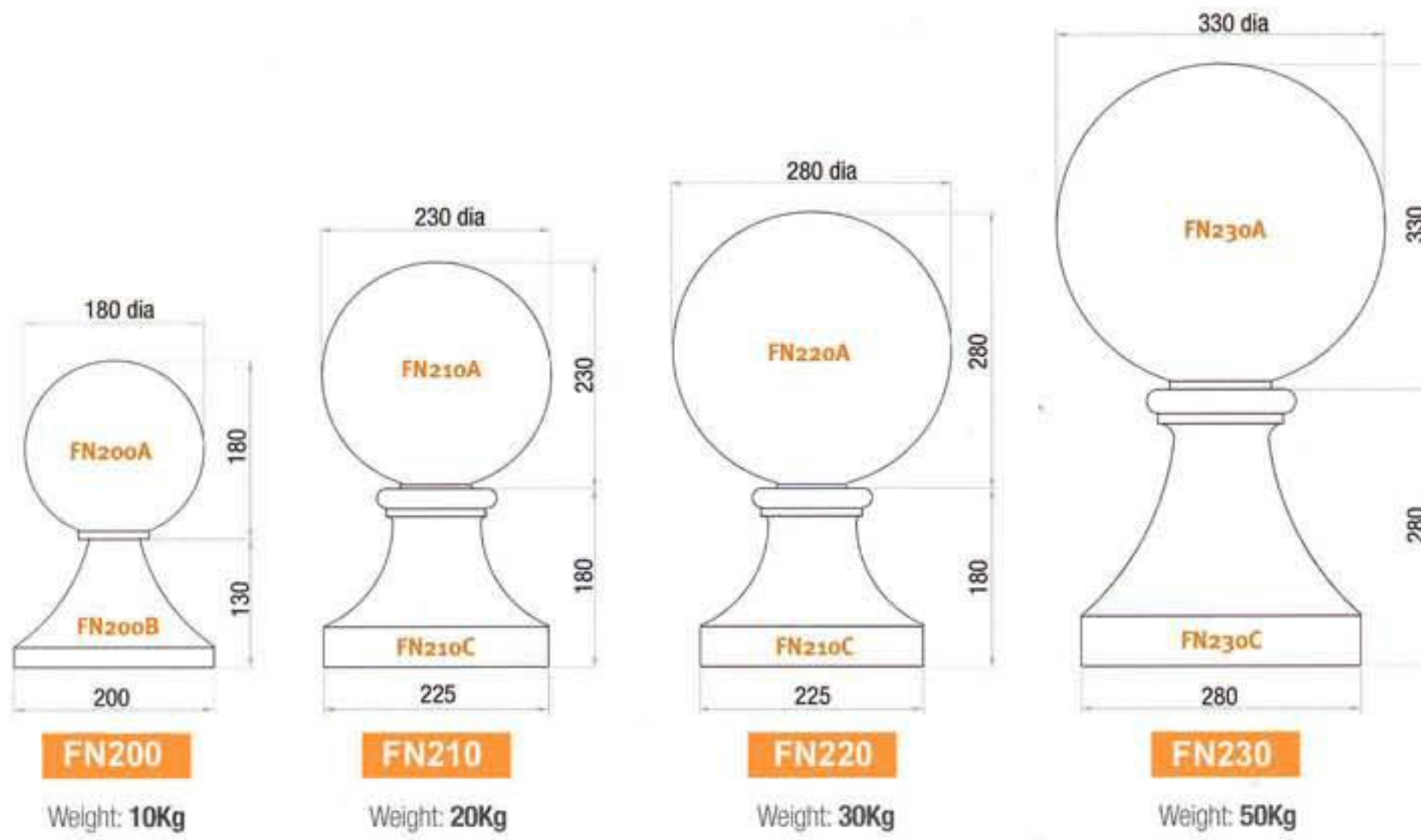

Finials



FN300

FN240A

FN230C

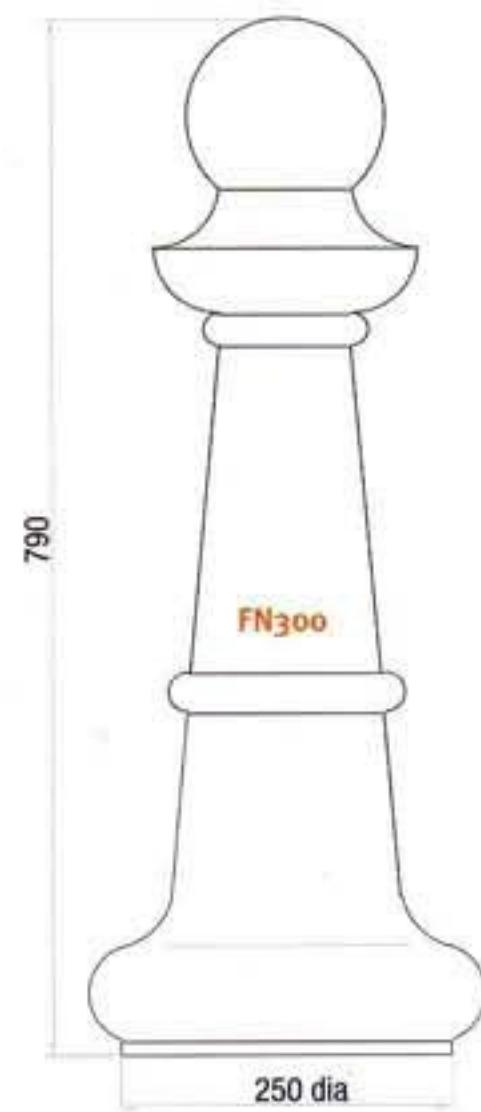

Weight: 118Kg

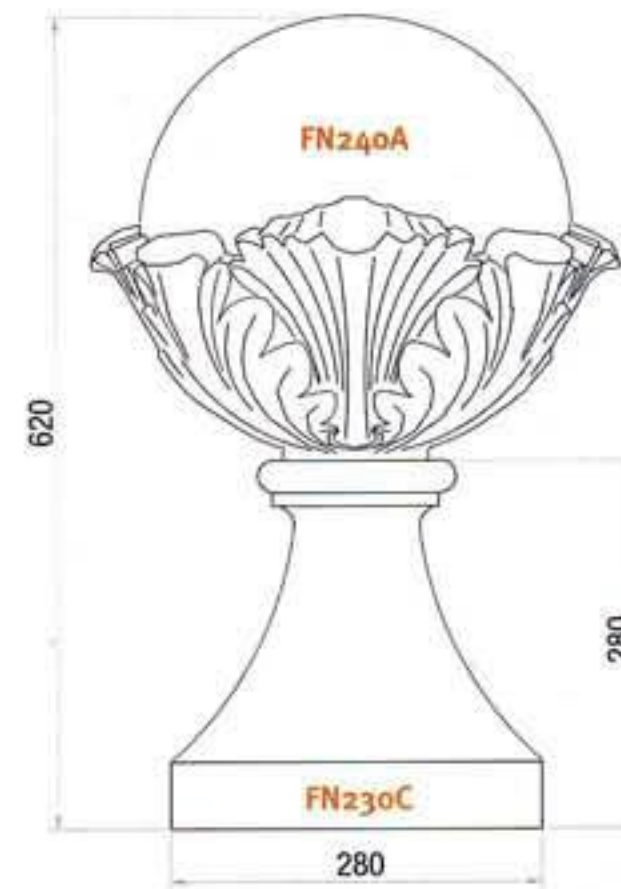

Weight: 55Kg

FN100

FN110

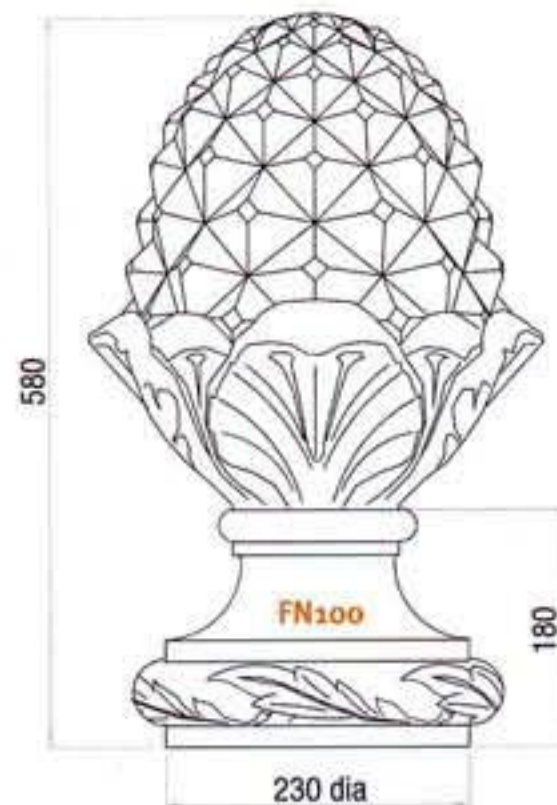

Weight: 40Kg



Weight: 40Kg

Date & Name Stones

These items are produced as blanks for carving to customers requirements. Many type font styles are available to suit the customers needs.



RS1



Weight: 48Kg



Weight: 48Kg

RS2



RS3

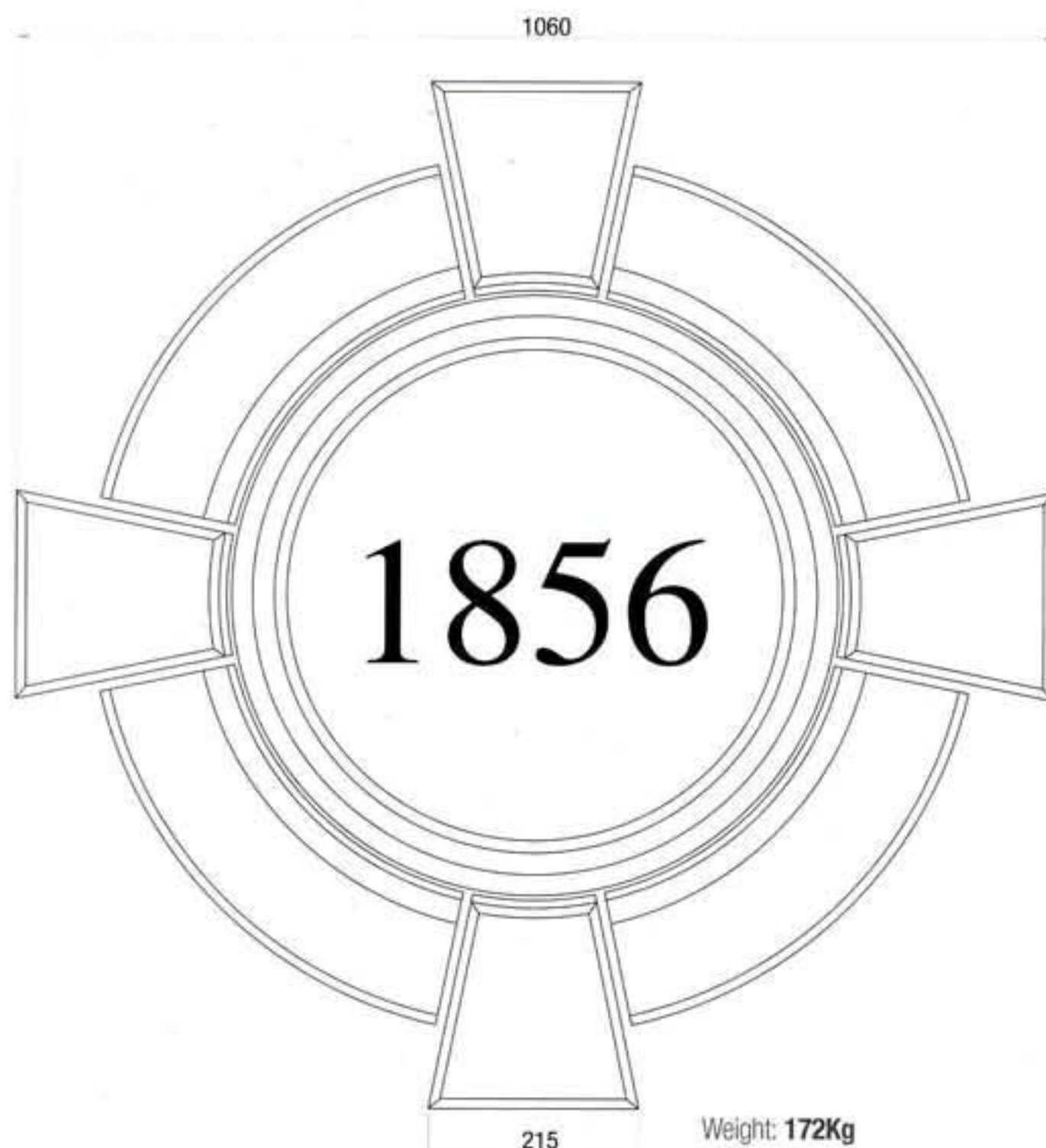

Weight: 172Kg

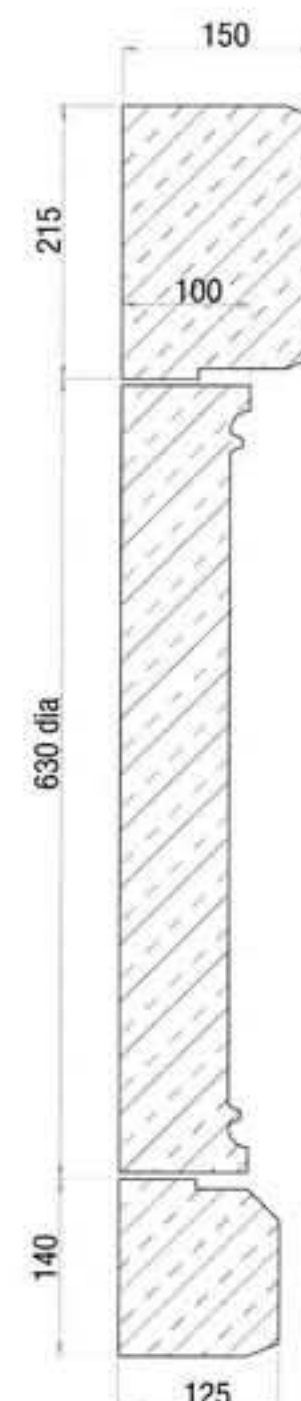

WILLISHOLME
2001

Date & Name Stones

These items are produced as blanks for carving to customers requirements.
Many type font styles are available to suit the customers needs.

DP10

Code	A	B	Weight (kg)
DP10	440	215	20
DP11	444	219	20
DP12	440	290	27
DP13	444	294	27
DP14	665	215	30
DP15	665	290	40
DP16	665	365	51
DP17	890	365	68
DP18	1115	365	85

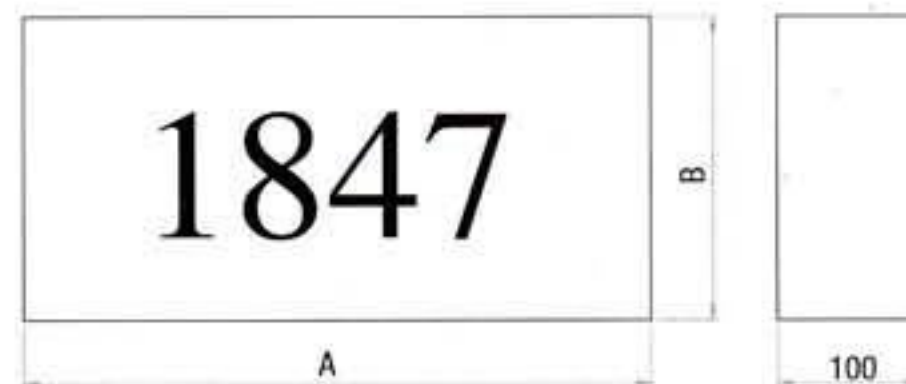

DP20

Code	A	B	Weight (kg)
DP20	440	215	18
DP21	444	219	18
DP22	440	290	24
DP23	444	294	24
DP24	665	215	27
DP25	665	290	36
DP26	665	365	46
DP27	890	365	62
DP28	1115	365	78

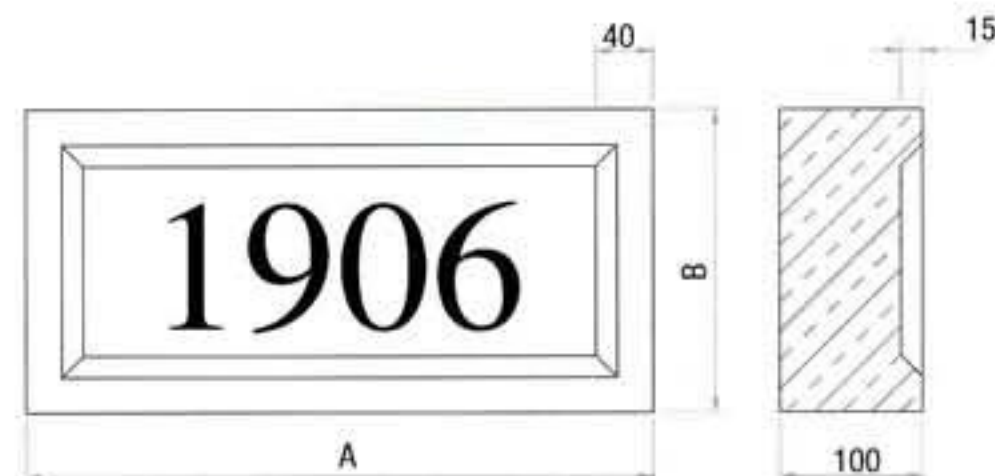

DP30

Code	A	B	Weight (kg)
DP30	440	215	24
DP31	444	219	24
DP32	440	290	32
DP33	444	294	32
DP34	665	215	36
DP35	665	290	48
DP36	665	365	61
DP37	890	365	81
DP38	1115	365	102

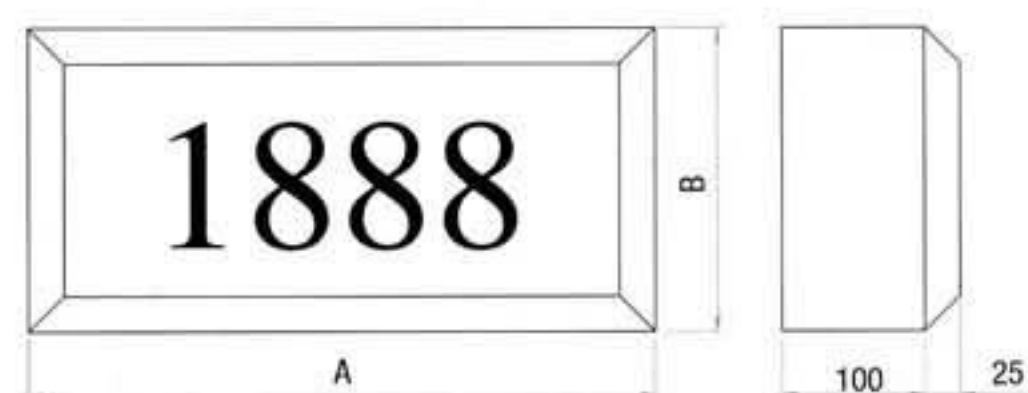

Date & Name Stones

These items are produced as blanks for carving to customers requirements. Many type font styles are available to suit the customers needs.



DP1

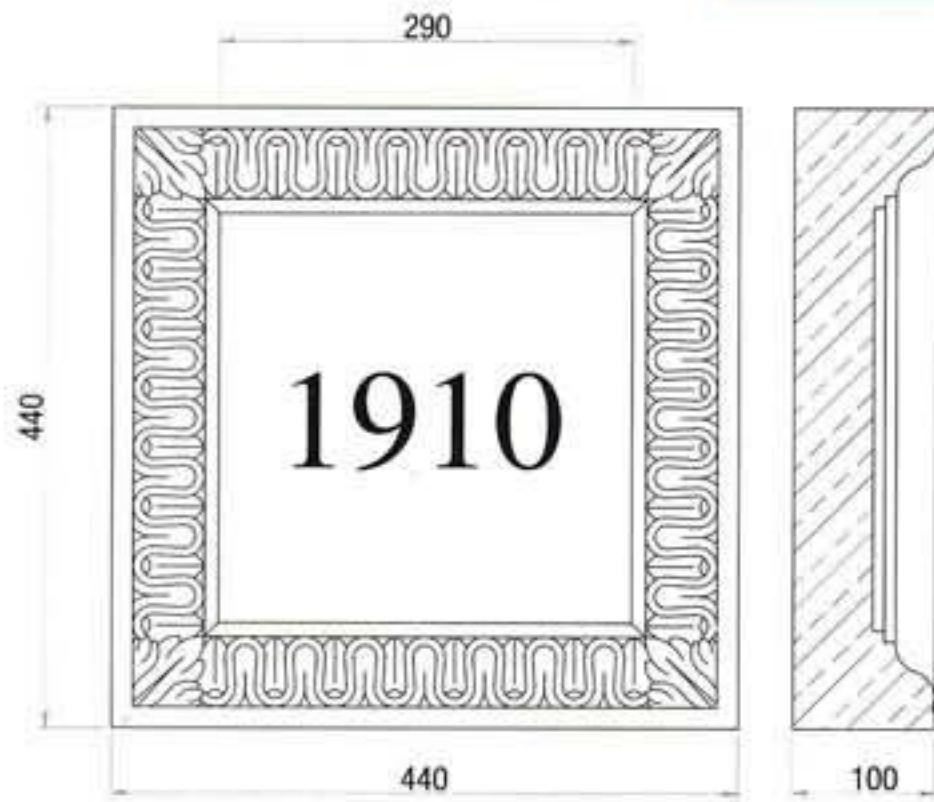

Weight: 27Kg

DP2

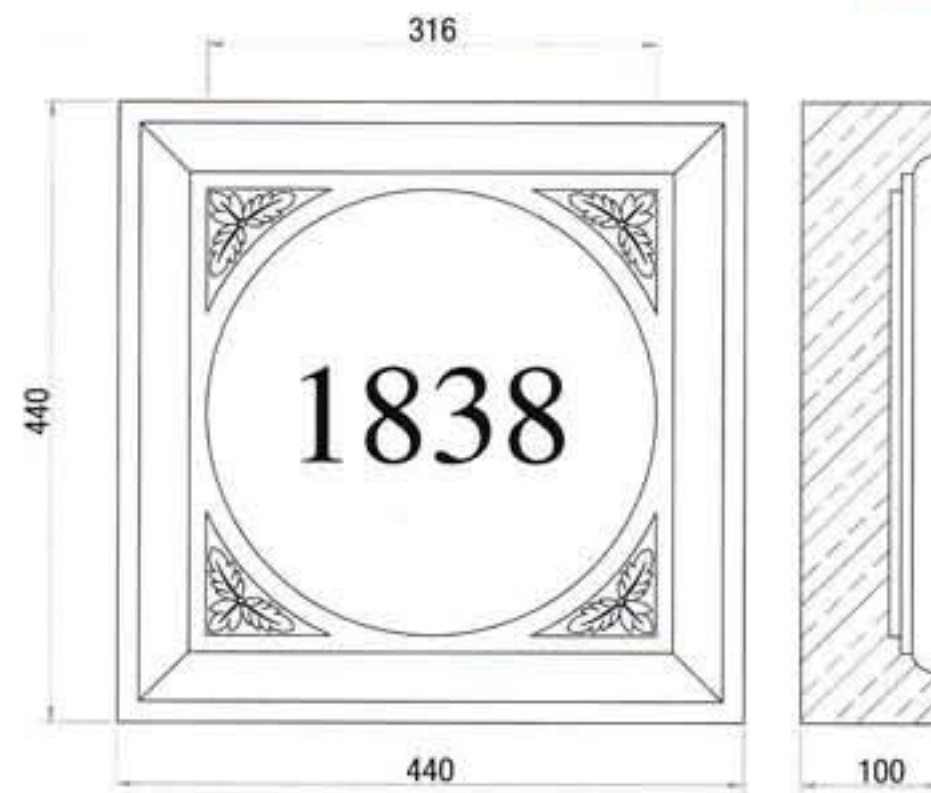

Weight: 30Kg

DP3

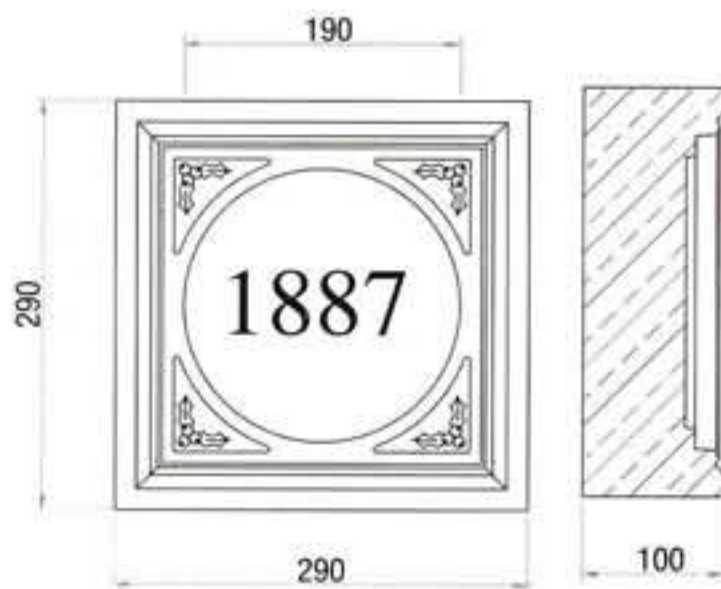

Weight: 14Kg

DP4

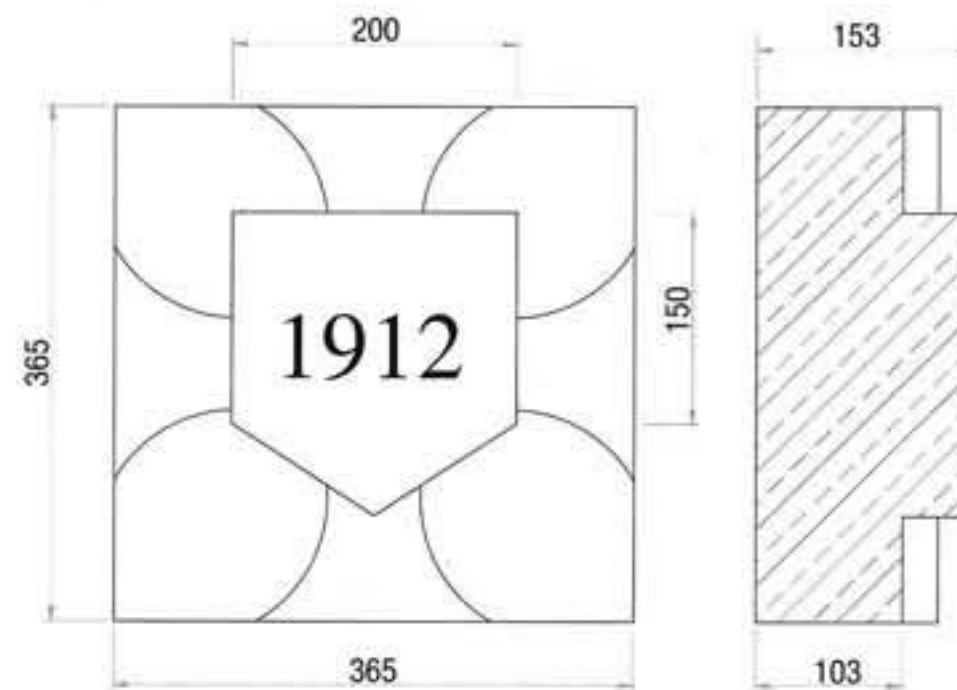

Weight: 36Kg

DP5

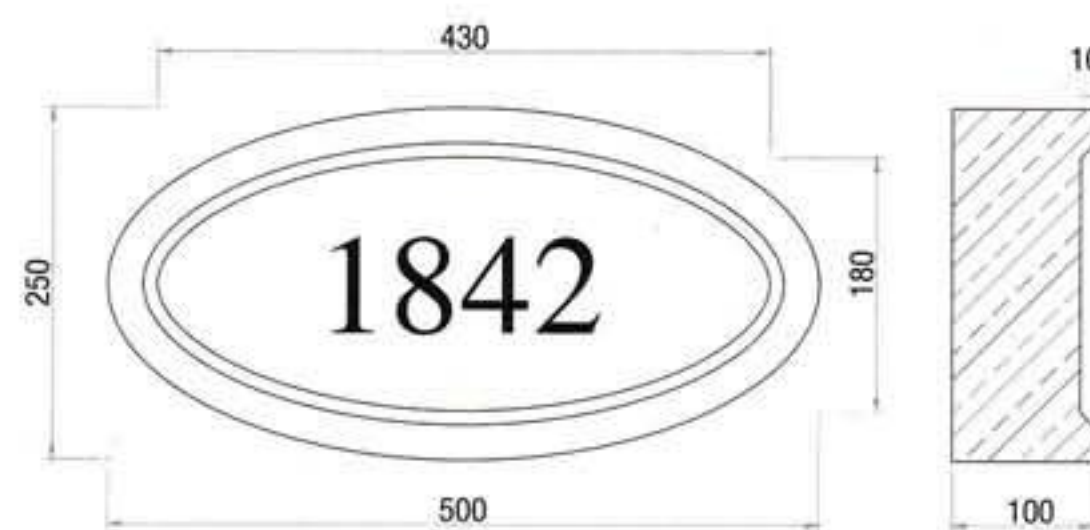

Weight: 19Kg



Date & Name Stones

These items are produced as blanks for carving to customers requirements.
Many type font styles are available to suit the customers needs.

DP40 (See table below)

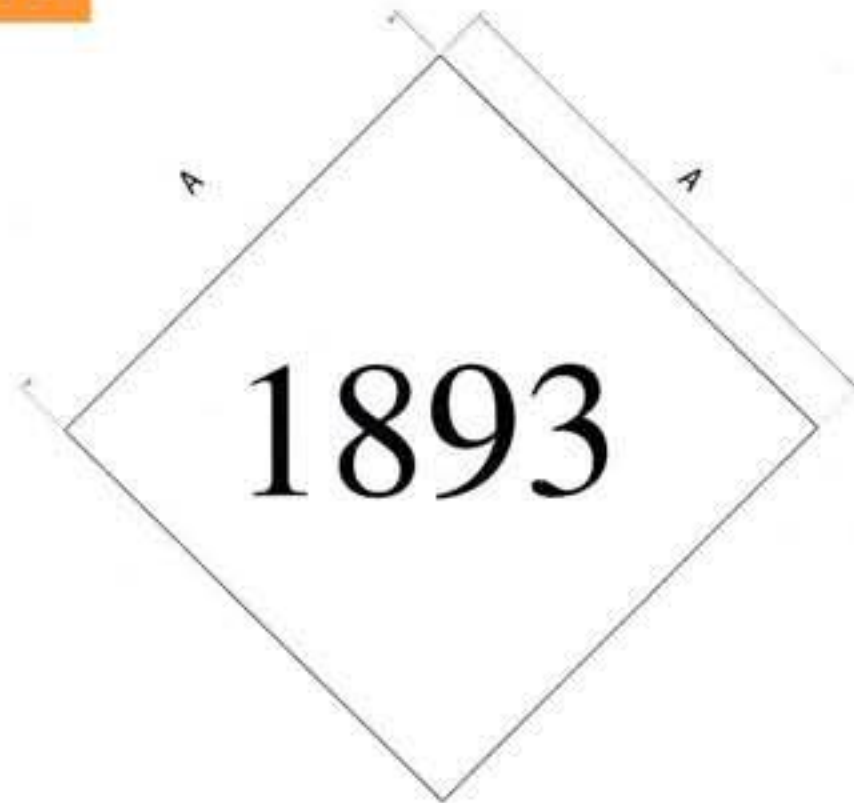

DP45

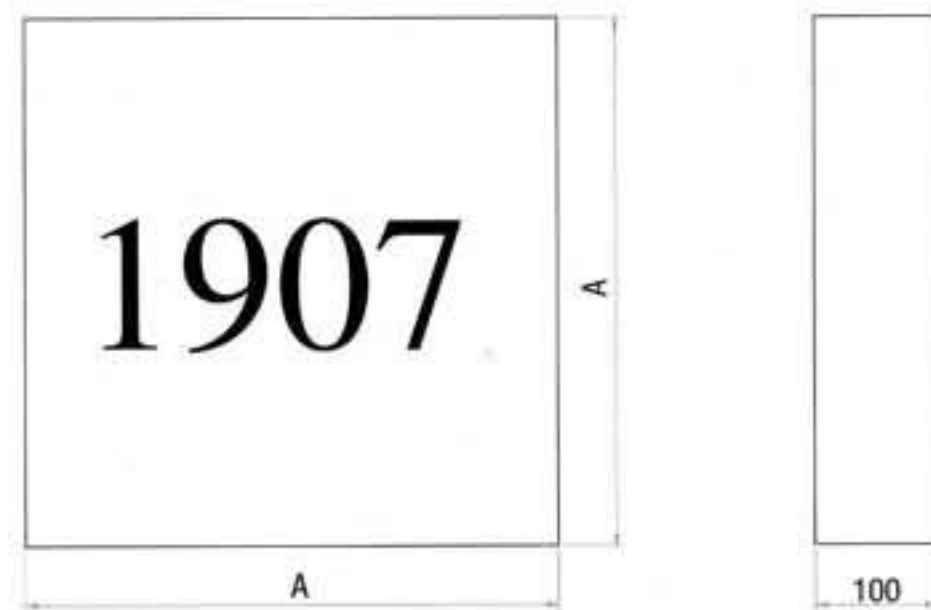

DP50 (See table below)

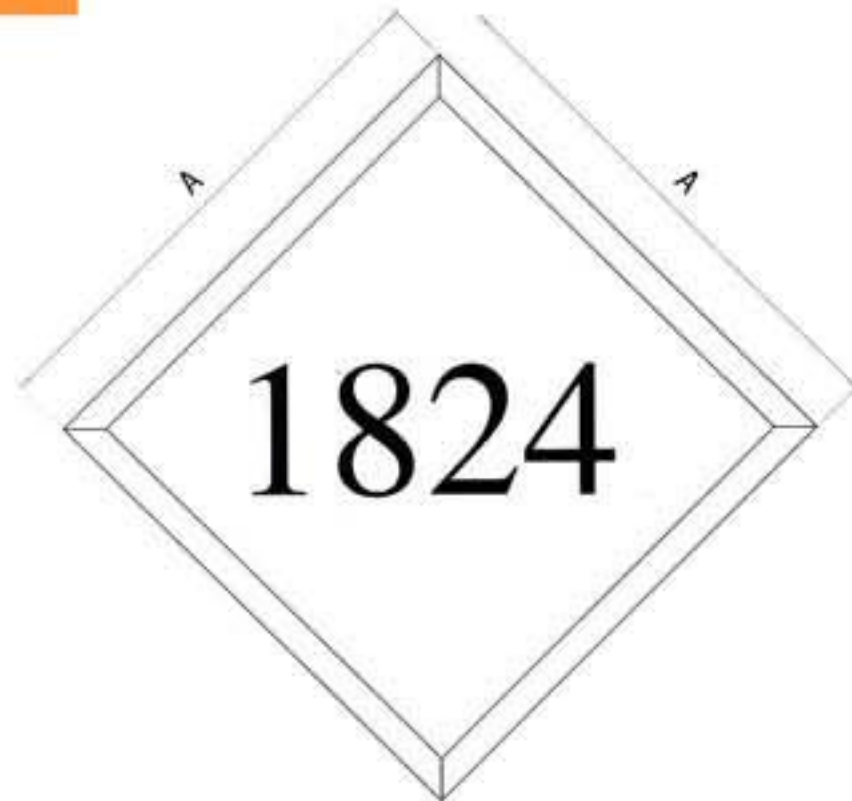

DP55

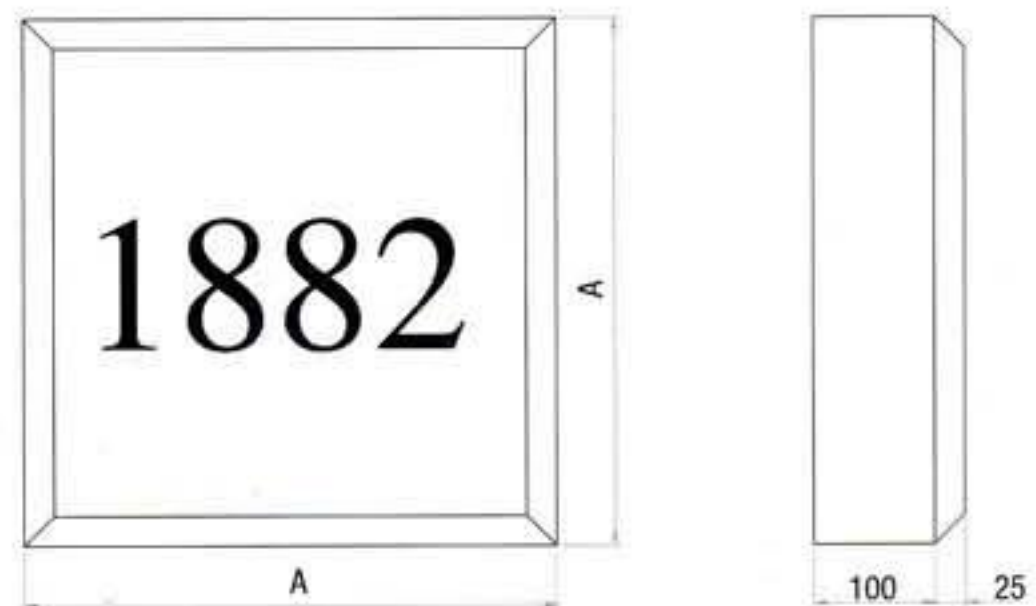

DP60 (See table below)

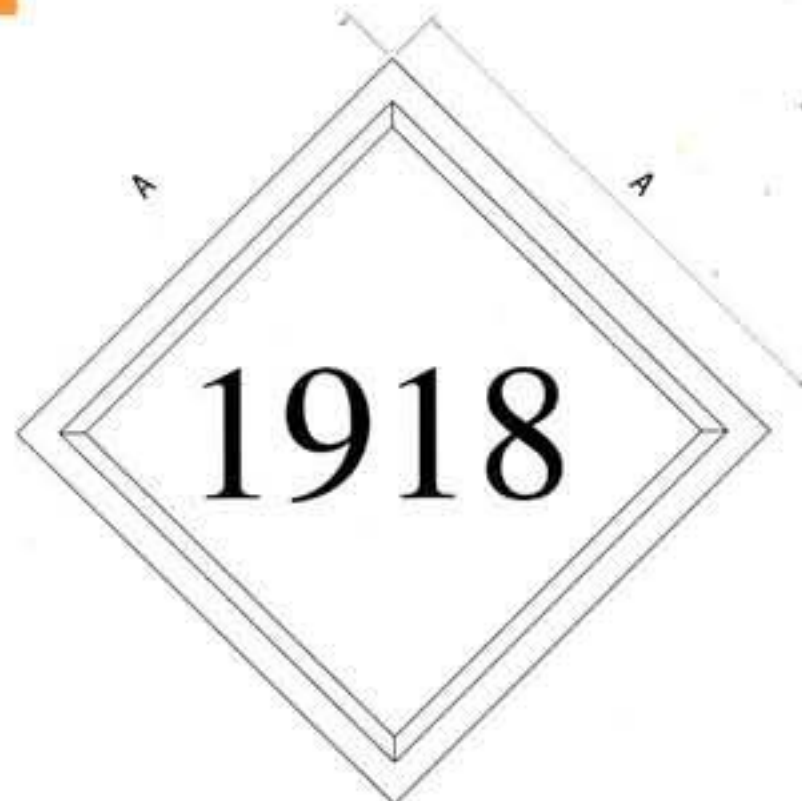

DP65

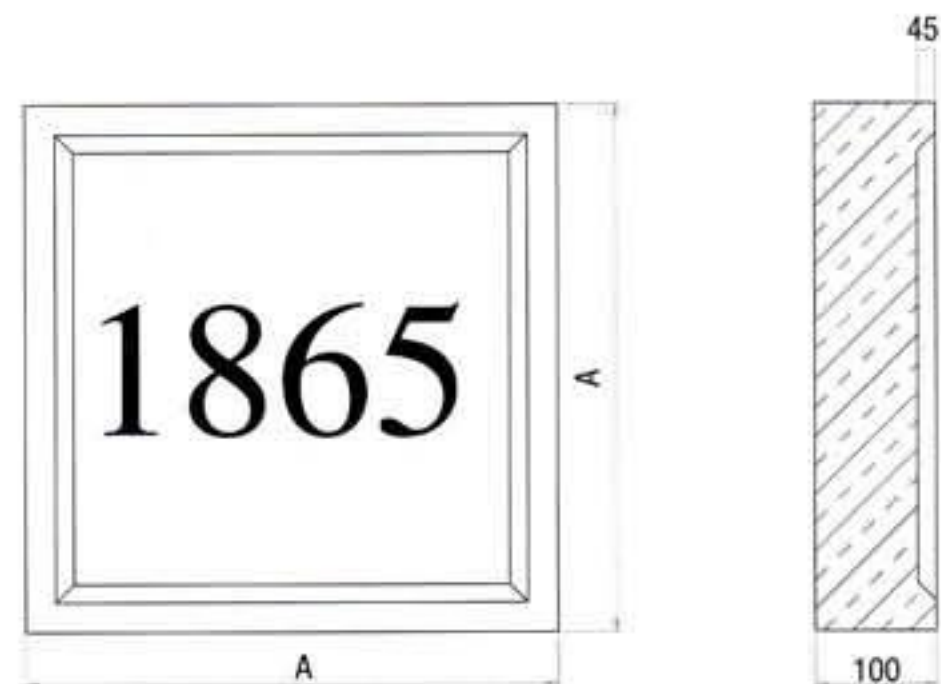

Code	A	Weight (kg)
DP40	290	18
DP41	440	41
DP42	444	41
DP43	665	93
DP44	890	166

Code	A	Weight (kg)
DP50	290	22
DP51	440	50
DP52	444	50
DP53	665	114
DP54	890	203

Code	A	Weight (kg)
DP60	290	17
DP61	440	38
DP62	444	38
DP63	665	85
DP64	890	144

Date & Name Stones



These items are produced as blanks for carving to customers requirements. Many type font styles are available to suit the customers needs.

Dimension 'A' = 3 x 'B' + 20mm

(See table below) **DP70**

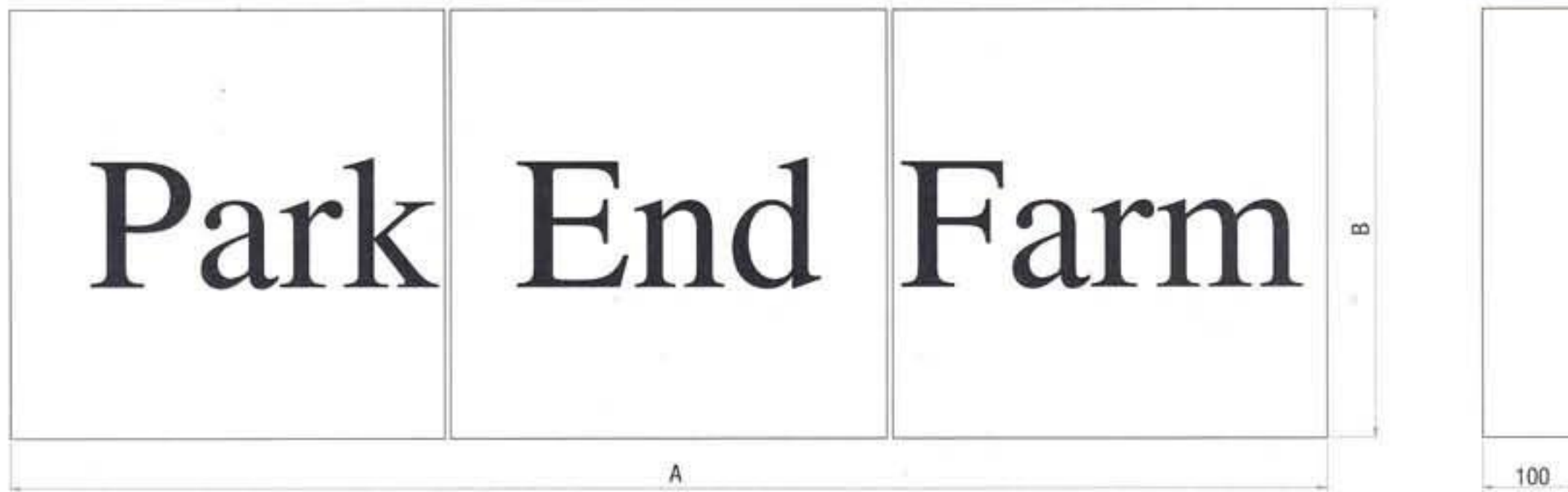

(See table below) **DP80**

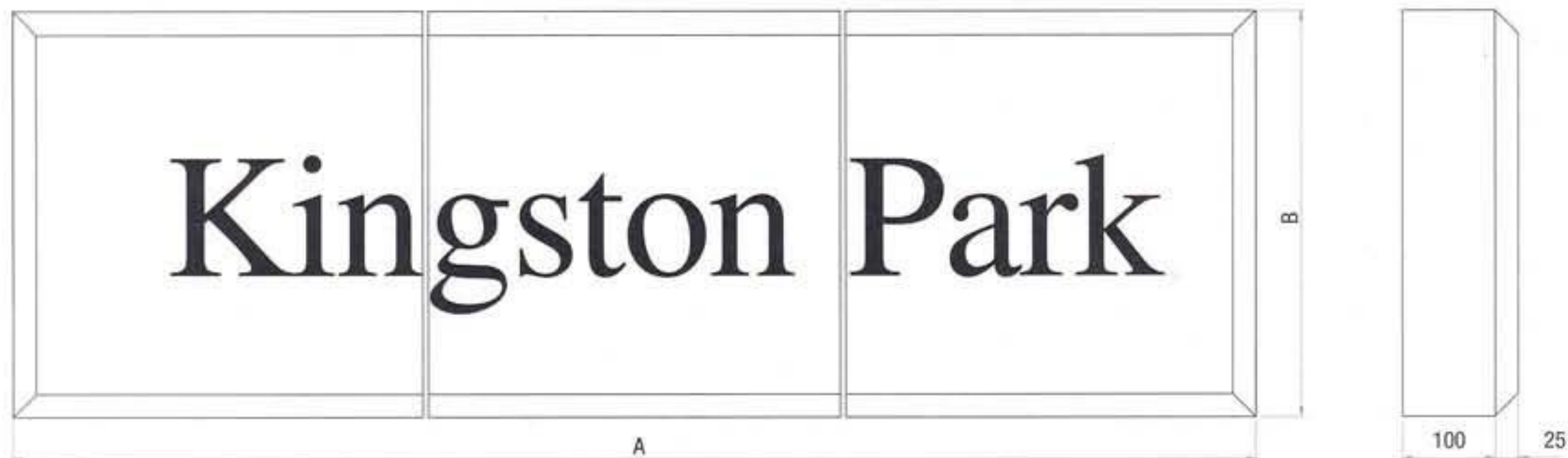

(See table below) **DP90**

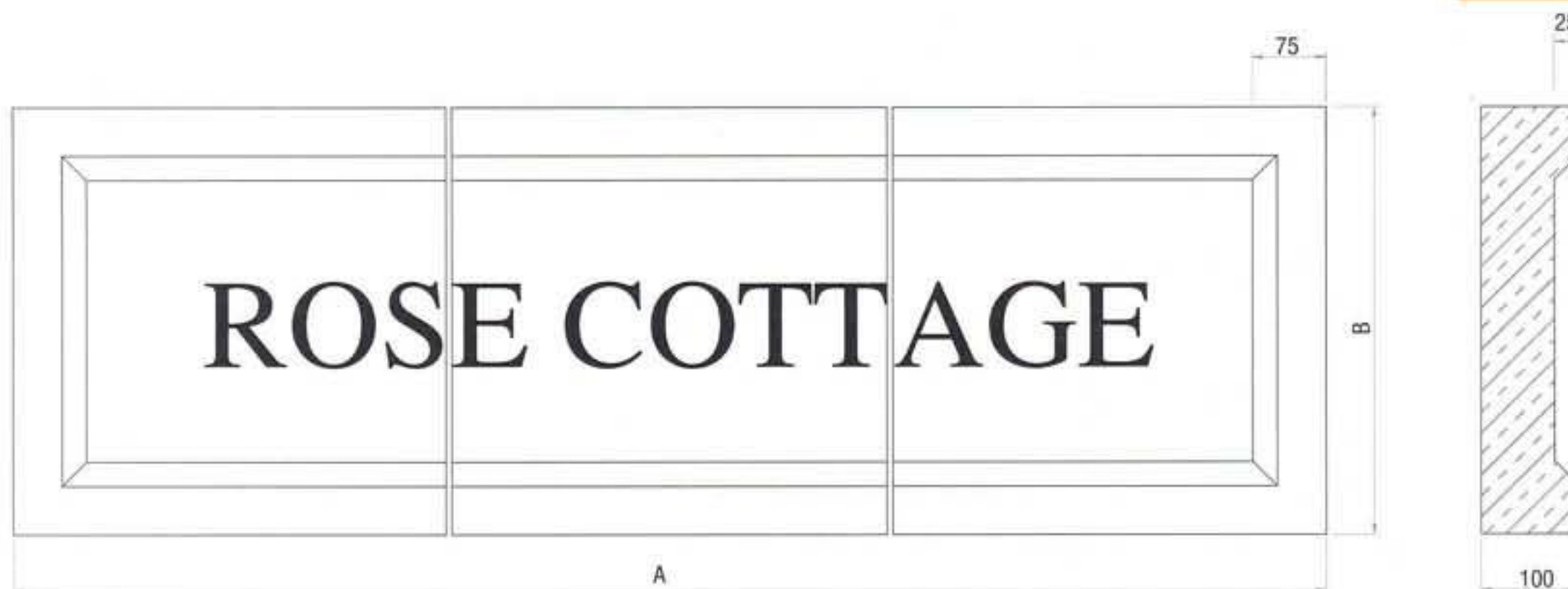

Code	A	Weight (kg)
DP70	440	92
DP71	525	110
DP72	600	126
DP73	725	152
DP74	890	187

Code	A	Weight (kg)
DP80	290	114
DP81	440	136
DP82	444	156
DP83	665	189
DP84	890	232

Code	A	Weight (kg)
DP90	290	75
DP91	440	89
DP92	444	101
DP93	665	120
DP94	890	147



Date & Name Stones

These items are produced as blanks for carving to customers requirements.
Many type font styles are available to suit the customers needs.

Dimension 'A' = 3 x 'B' + 20mm

DP100

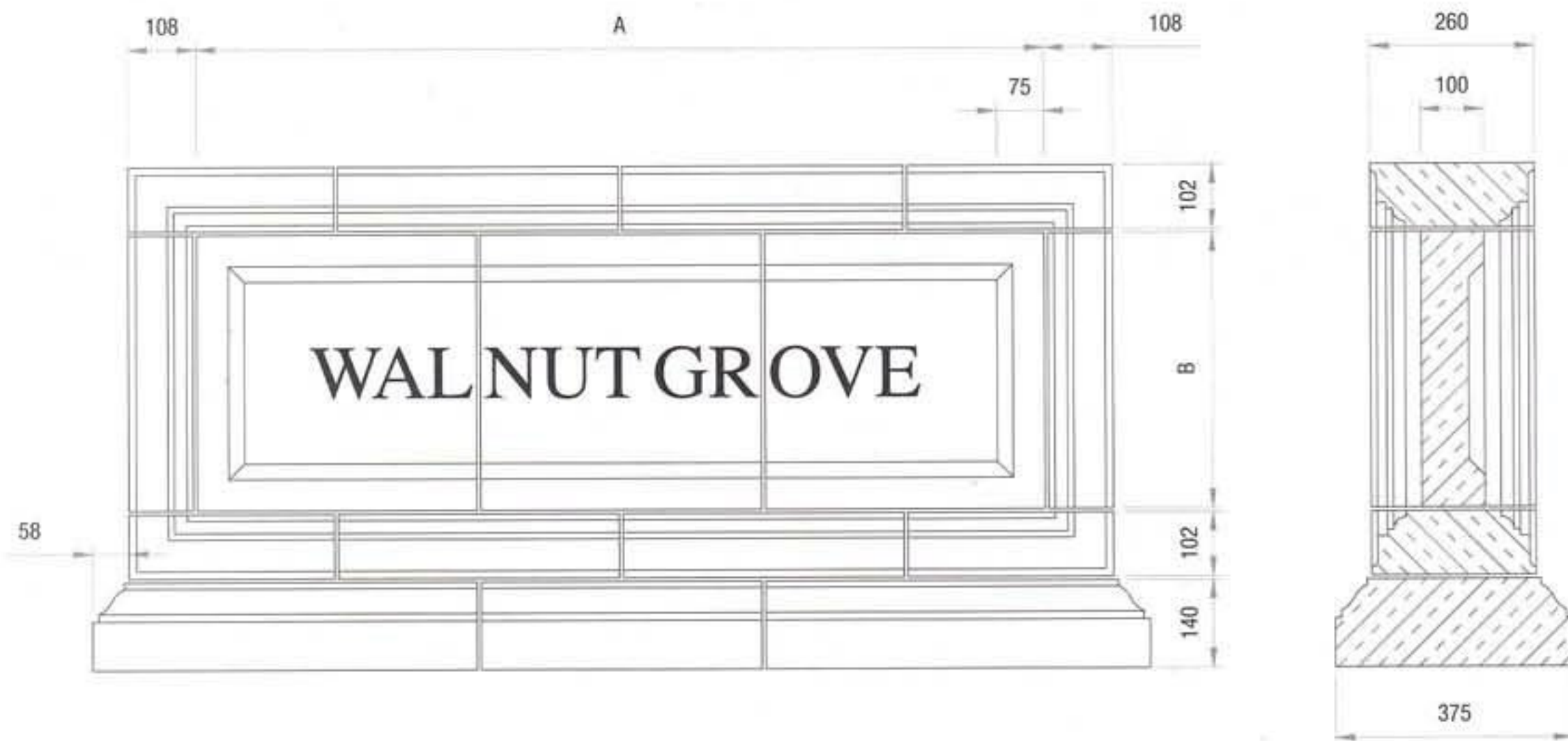

Code	B
DP100	440
DP101	525
DP102	600
DP103	725
DP104	890

DP200

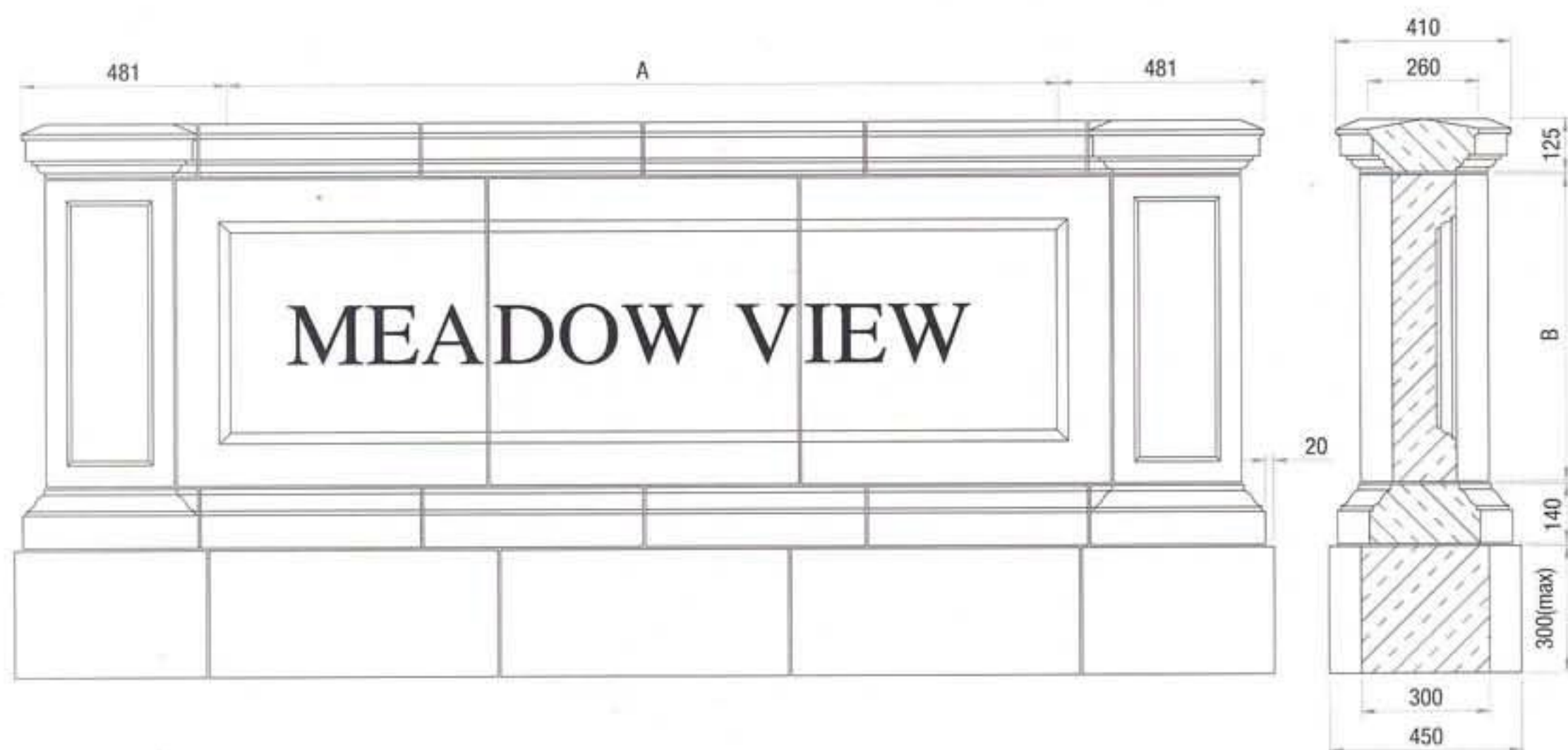

Code	B
DP200	440
DP201	525
DP202	600
DP203	725
DP204	890

Fireplace Surrounds

Fire surrounds that will accommodate standard gas fires can also be supplied.

Fire surrounds are supplied complete with fixings.



The Library **CP10**

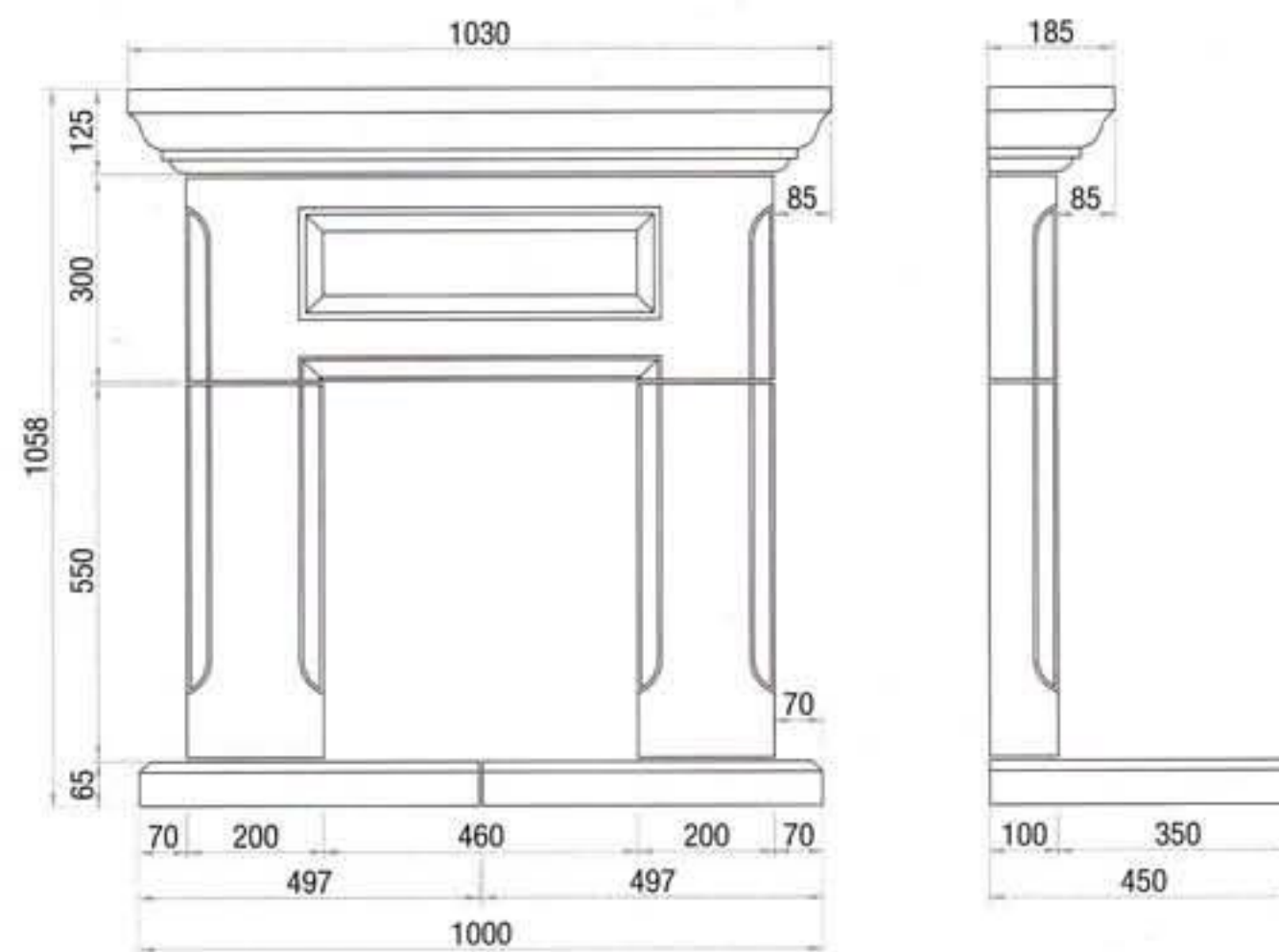

Total Weight: 195Kg

The Boningdale **CP20**

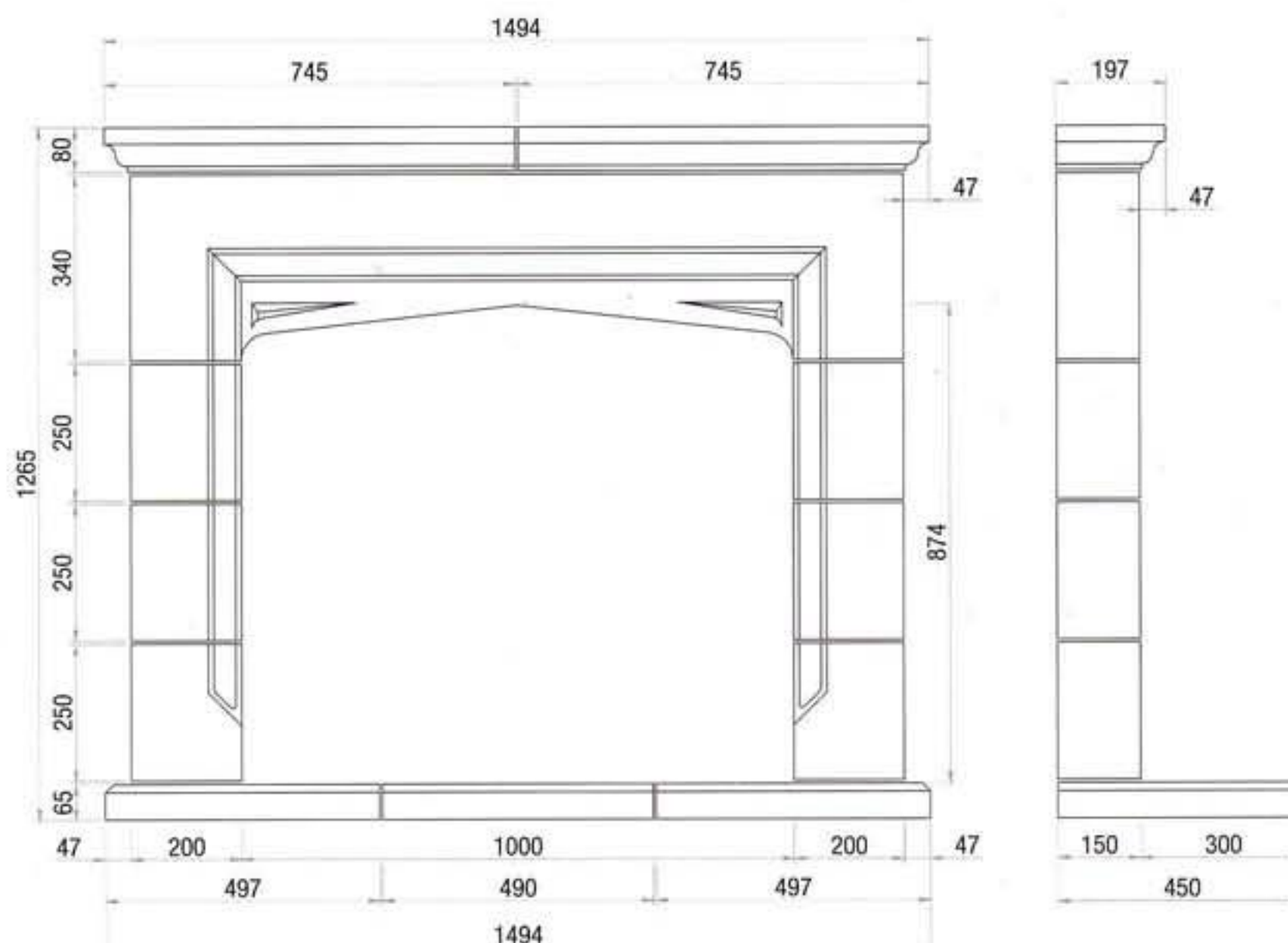

Total Weight: 355Kg



Fireplace Surrounds

Fire surrounds that will accommodate standard gas fires can also be supplied.

Fire surrounds are supplied complete with fixings.

CP40 The Rockingham

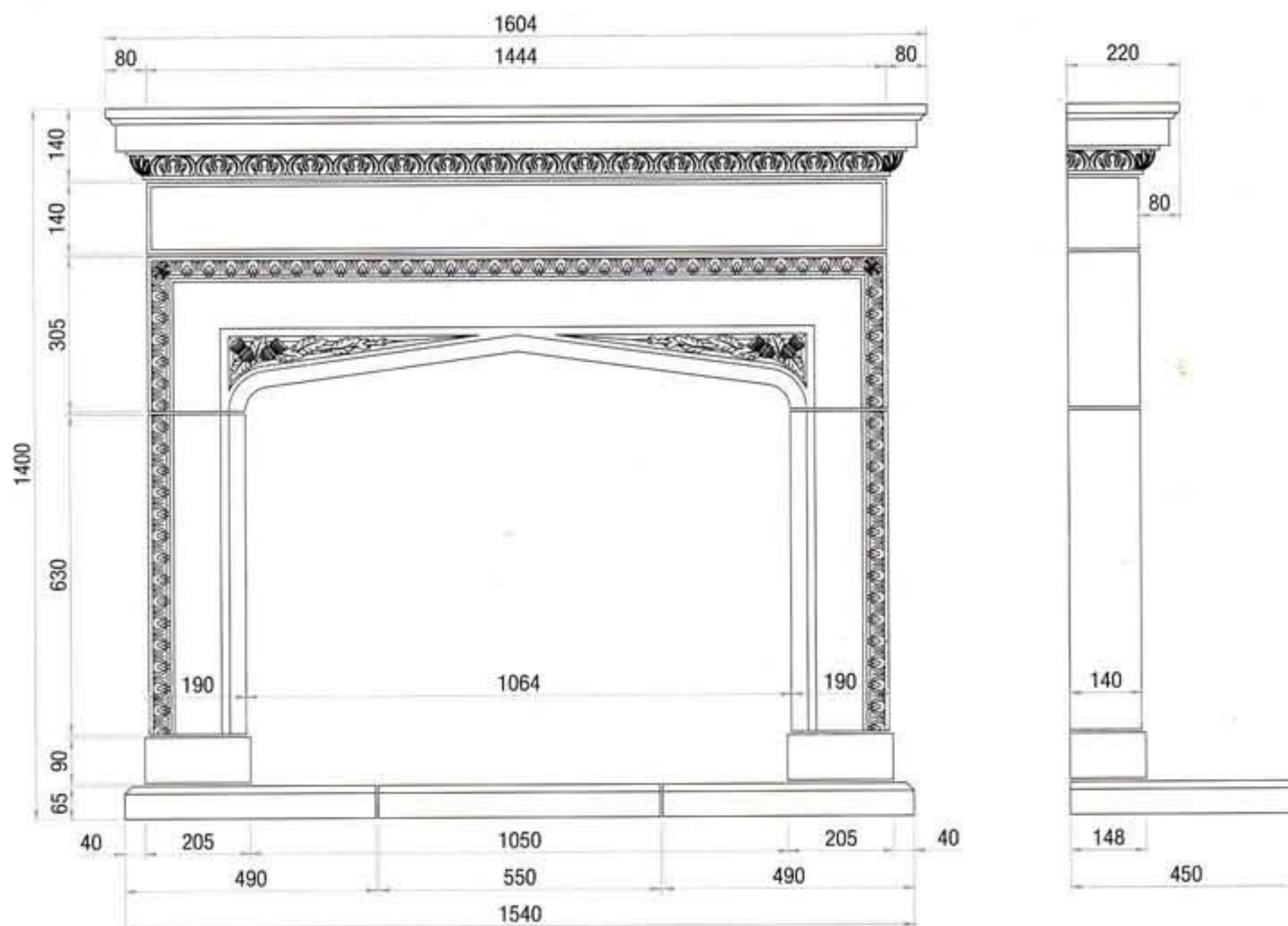

Total Weight: 390Kg

CP40 Thistle Motif

CP41 Rose Motif

CP42 Shamrock Motif

