



SR-70

Hydraulic
Rotary Rig

LDP
LHR
CFA
CAP
TJ

DP
RCDS
DW

Hydraulic Rotary Rig **SR-70**

soilmec 
Drilling and Foundation Equipment

Rotary

Soilmec rotaries are designed and manufactured to meet the need for increased production and performance on various applications, with the added benefit of increased component life and reliability.

Ease of transport and quick assembly

- Counterweight with a self-handling system (service crane not required).
- Crawlers can be retracted to respect wide transport requirements.

Compact powerful engine

Soilmec installs large displacement engines, providing exceptional performance and reliability.

- High performance, availability and reliability by using tried-and-tested technology with high power-to volume-ratio.
- The modern electronic injection system ensures low fuel consumption and therefore low operating costs.
- Low noise emissions, smooth running characteristics and durability.
- Meets exhaust emission regulations 2004/26/EU, Step III A and US-EPA Tier 3.

DMS control system

DMS is an innovative system, developed by Soilmec, which controls and monitors the operation of the machine. For ease of operation the system is controlled by a touch screen located in the cab. The system main function, is to enable the machine to perform different functions more efficiently.

A dedicated power module electronic control system ensures the main pumps and Diesel engine work at their most effective and productive levels.

Ergonomic design

The cab is designed to be spacious, quiet and comfortable for the operator, assuring high productivity throughout the working day. Controls are conveniently located for easy operation.

The Soilmec advantage

- A real multifunctional machine, designed from scratch to give you the best drilling solution.
- Long life expectancy with a high residual value.
- Best price/performance ratio.
- Built with the customer in mind.





- 1** Undercarriage
- 2** Turret
- 3** Winches
- 4** Parallelogram system
- 5** Self-erecting mast
- 6** Cathead
- 7** Crowd system
- 8** Rotary head
- 9** Telescopic kelly bar
- 10** Self erecting counterweight
- 11** Cab

Deutz TCD 2015-V06		
Power @ 1900 rpm	330 kW	442 HP
Operating weight (approx) with kelly 4x13,5 m	86000 kg	189597 lb
Torque	271 kNm	199629 lbfft
Max diameter	2500 mm	98.4 in
Max depth	77,4 m	253.9 ft

LDP - KELLY DRILLING SYSTEM

Crowd Winch Version

The hydraulic drilling rig SR-70 has been specially designed to suit the following applications:

- **cased bored piles** with casing driven directly by rotary head or optionally by casing oscillator powered by the base carrier itself;
- **deep uncased bored piles** stabilized by drilling fluid or dry hole;
- **LHR (Low Headroom)** special rig configuration dedicated to confined headroom spaces;
- **CFA (Continuous Flight Auger) piles** by means of long auger string;
- **CAP (Cased Augered Piles) piles** with double rotary system;
- **DP (Displacement piles)** *on demand*;
- **TJ (Turbojet)** - soil consolidation *on demand*;
- **soil-mixing** - soil consolidation *on demand*;
- **RCDS (Reverse Circulation Drilling System)** *on demand*;
- **DW** it can be converted into **Diaphragm Wall base machine** to work with an **hydraulic grab** *on demand*.

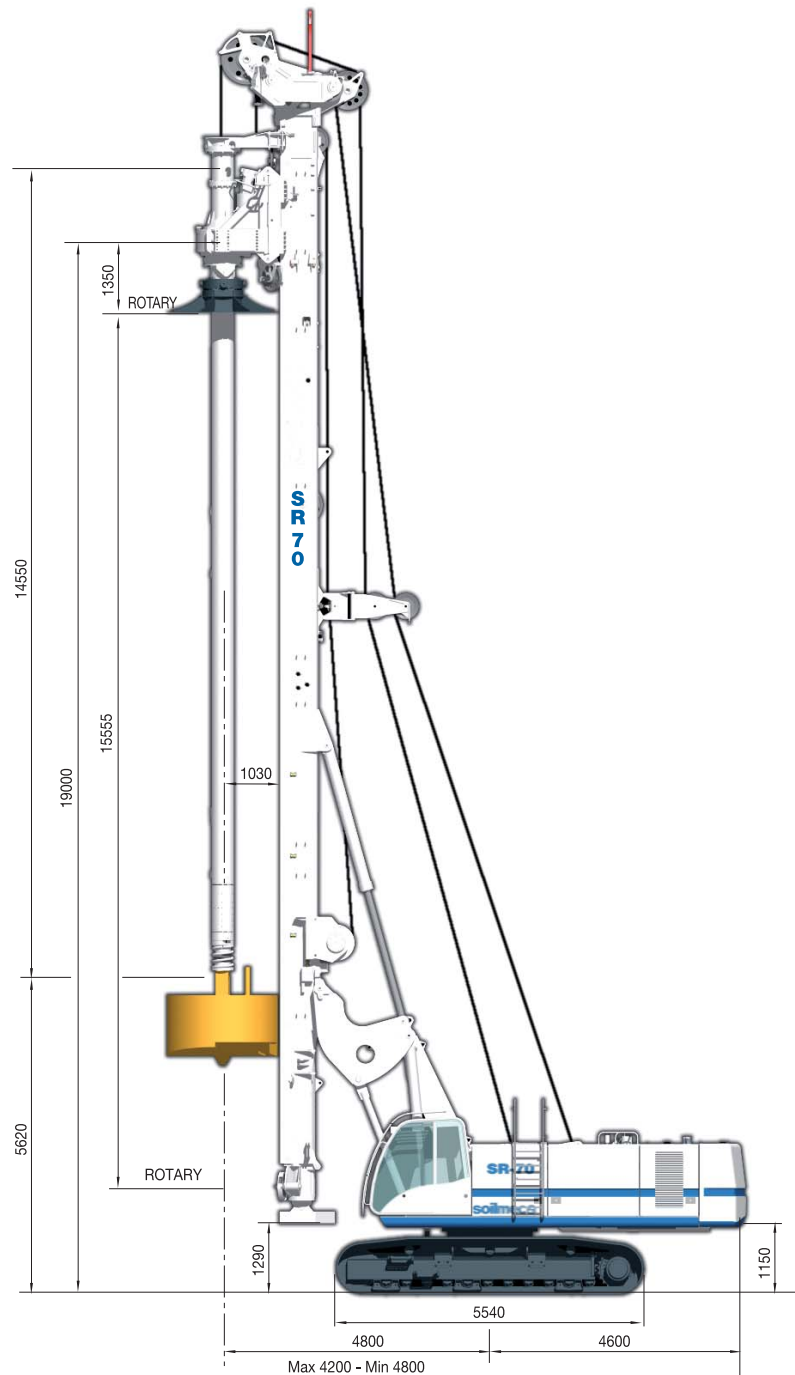

DMS - Drilling Mate System

The SR-70 in kelly version is equipped with the DRILLING MATE SYSTEM (DMS) on 12" touch screen to monitor and control the operating parameters. The standard DMS equipment is composed of:

- PLC controller for all electrically actuated functions
- fault checking and reporting
- monitor unit designed to display:

- engine information and diagnostic capability
- pump pressures
- mast verticality
- drilling depth
- rotary speed and pressure
- crowd pressure
- graphics drilling charts.

The following additional optional features are available:

- automatic turret hole centering
- automatic mast vertical alignment

- operating data storage on memory card
- DMS PC software package for production data analysis and job site daily reporting
- DMS MANAGER for remote control and transmission of process and operating data and tele assistance.







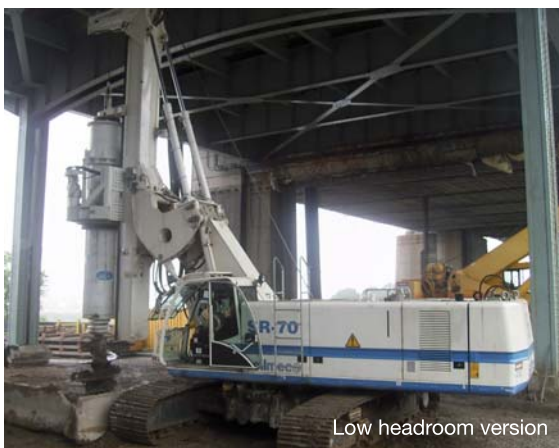

DMS
DRILLING MATE SYSTEM

LDP - KELLY DRILLING SYSTEM

Crowd Cylinder Version



TECHNICAL DATA

	Crowd cylinder		Crowd winch		
Overall height	22699 mm	894 in	22699 mm	894 in	
Operating weight (approx) with kelly 4x13,5 m	82000 kg	180777 lb	86000 kg	189596 lb	
	Rotary Drive - RD-250 single gear version				
	-Torque (nominal)	253 kNm	186600 lb _f ft	253 kNm	186600 lb _f ft
	-Speed of rotation (max)	26,7 rpm	26.7 rpm	26,7 rpm	26.7 rpm
	-Spin-off speed	125 rpm	125 rpm	125 rpm	125 rpm
	Rotary Drive - RD-270G multi gear version				
	-Torque (nominal)	271 kNm	199876 lb _f ft	271 kNm	199876 lb _f ft
	-Speed of rotation (max)	54,4 rpm	54.4 rpm	54,4 rpm	54.4 rpm
	-Spin-off speed	115 rpm	115 rpm	115 rpm	115 rpm
	Crowd system				
	-Crowd force (pull down/up) nominal	201 / 280 kN	45186 / 62945 lb _f	350 / 350 kN	78682 / 78682 lb _f
	-Stroke (kelly system)	6500 mm	256 in	15555 mm	612 in
	-Stroke (CFA system)	21650 mm	852 in	15790 mm	622 in
	-Speed (down/up)	4,5 / 10 m/min	14.7 / 32.8 ft/min	8,4 / 18,8 m/min	27.5 / 61.6 ft/min
	-Fast speed (down/up)	11,4 / 10 m/min	37.4 / 32.8 ft/min	18,8 / 18,8 m/min	61.6 / 61.6 ft/min
	Main winch SW-250				
		controlled descent	controlled descent	controlled descent	controlled descent
	-Line pull (1st layer) effective/nominal	210 / 250 kN	47210 / 56202 lb _f	210 / 250 kN	47210 / 56202 lb _f
	-Rope diameter/length	30 mm / 159 m	1.18 in / 521 ft	30 mm / 159 m	1.18 in / 521 ft
	Auxiliary winch SF-240				
		free fall	free fall	free fall	free fall
	-Line pull (1st layer) effective/nominal	198 / 235 kN	44511 / 52899 lb _f	198 / 235 kN	44511 / 52899 lb _f
	-Rope diameter/length	30 mm / 156 m	1.18 in / 511 ft	30 mm / 159 m	1.18 in / 521 ft
	Auxiliary winch SW-140				
		controlled descent	controlled descent	controlled descent	controlled descent
	-Line pull (1st layer) effective/nominal	122 / 145 kN	27426 / 32597 lb _f	122 / 145 kN	27426 / 32597 lb _f
	-Rope diameter	26 mm	1.02 in	26 mm	1.02 in
	Auxiliary winch SF-140				
		free fall	free fall	free fall	free fall
	-Line pull (1st layer) effective/nominal	123 / 147 kN	27651 / 33046 lb _f	123 / 147 kN	27651 / 33046 lb _f
	-Rope diameter/length	26 mm	1.02 in	26 mm	1.02 in
	Mast inclination				
	-Backward/forward/lateral	10 / 4 / 3 °	10 / 4 / 3 °	10 / 4 / 3 °	10 / 4 / 3 °

Soilmec integrates high quality level components: Gearmatic, Hydromatic, Lohmann, Rothe erde, Trasmital, Zollern.

Standard equipment

- Rotary drive single gear version
- Main winch controlled descend type
- Main and auxiliary winch grooved drums
- Hoist limit switch on main and auxiliary winches
- Swivel for main rope
- Crowd in fast or slow mode
- Service rope parking point

Measuring and control equipment

- PLC processor for all electrically actuated functions
- DMS system electronic monitoring and visualization system
- Mast inclination measurement on X/Y axes (*digital/analog display*)
- Automatic vertical alignment of mast
- Depth measuring devise on main winch
- Speed measuring device on rotary
- Crowd pressure setting



Turbojet version

TECHNICAL DATA - ROTARY DRIVE

Rotary RD-250

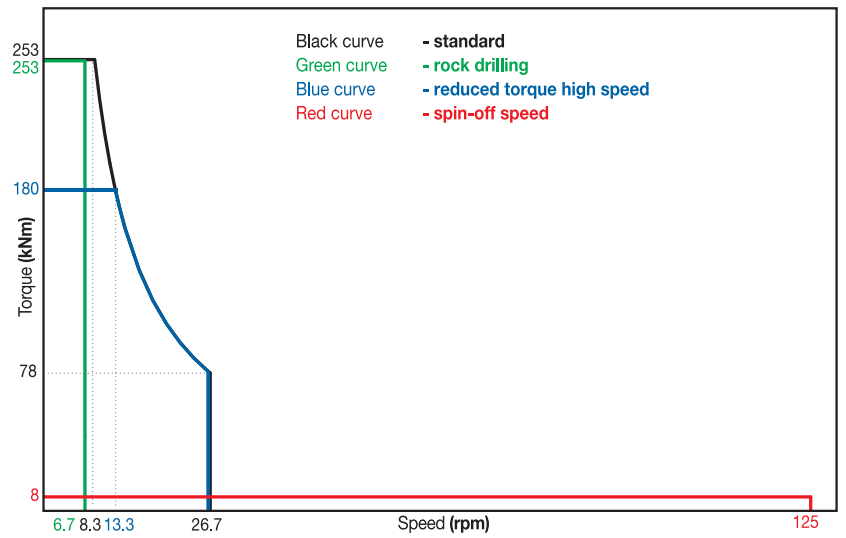
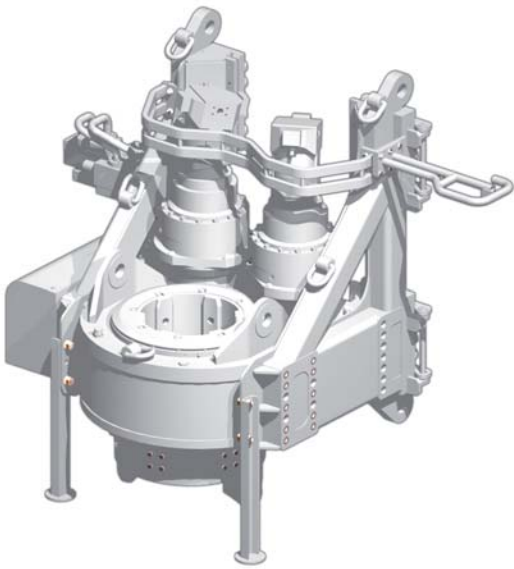

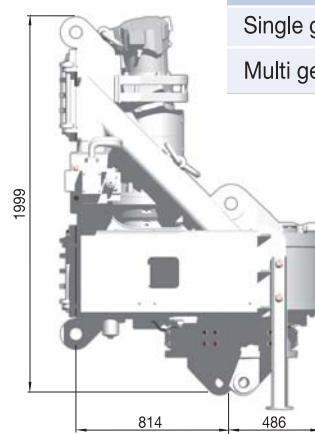
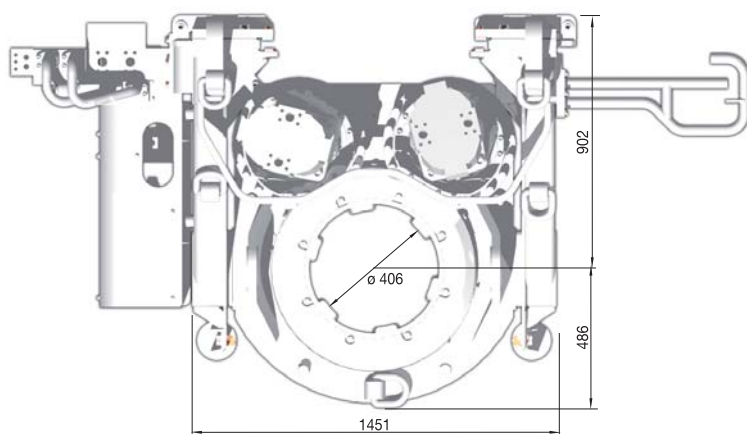
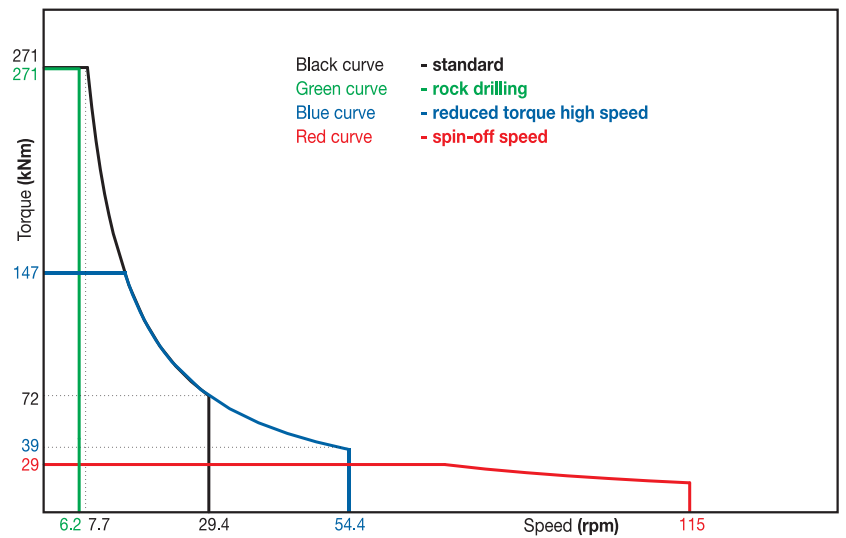
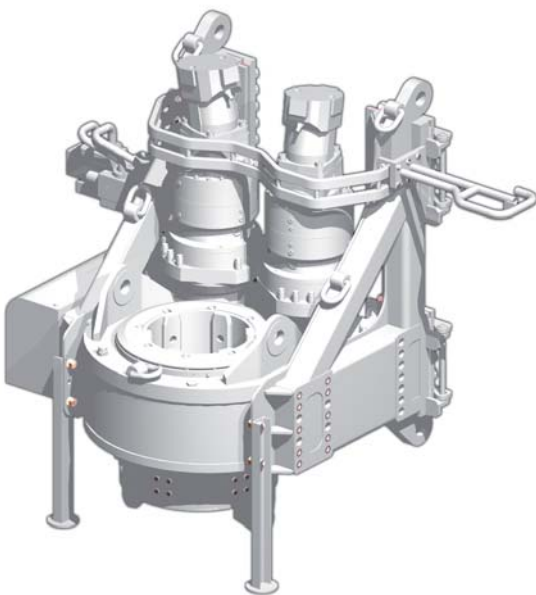

Rotary RD-270 G



Rotary	Weight	
Single gear version	5600 kg	12346 lbs
Multi gear version	6100 kg	13448 lbs

TECHNICAL DATA - BASE CARRIER



	Engine	Deutz TCD2015-V06	<i>Deutz TCD2015-V06</i>
	-Rated output ISO 3046-I	330 kW @ 1900 rpm	<i>442 HP @ 1900 rpm</i>
	-Engine conforms to Exhaust emission Standard	EU stage III, EPA CARB Tier 3	<i>EU stage III, EPA CARB Tier 3</i>
	-Diesel tank capacity	565 l	<i>149.2 US gal</i>
	-Sound pressure level in cabin (EN791 Annex A)	80 dB (A)	<i>80 dB (A)</i>
	-Sound power level (2000/14EG u. EN791, Annex A)	110 dB (A)	<i>110 dB (A)</i>
	Hydraulic system*		
	-Hydraulic pressure	300 bar	<i>4786 psi</i>
	-Flow rates (main circuits)	2 x 304 l/min	<i>2 x 80 US gal/min</i>
	-Hydraulic oil tank capacity	800 l	<i>211 US gal</i>
	Undercarriage* (retractable crawler frames)		
	-Crawler type	D7F	<i>D7F</i>
	-Overall width of crawlers (retracted/extended)	2980 / 4480 mm	<i>117 / 176 in</i>
	-Width of triple grouser track shoes	900 mm	<i>35 in</i>
	-Overall length of crawlers	5544 mm	<i>218 in</i>
	-Traction force effective/nominal	415.4 / 494.6 kN	<i>93385 / 111190 lb_f</i>
	-Travel speed	1,6 km/h	<i>1.0 mph</i>

* Soilmec integrates high quality level components: Berco, Rexroth, Trasmital.

Standard equipment

- Oscillator attachment
- Engine emergency operation mode
- Engine diagnostic system
- Hydraulic functions diagnostic panel
- Removable crawler side frames
- Transport securing rods on crawler units
- Access ladder on upper carriage
- On-board lighting set
- On-board tool set
- Electric refuelling pump
- High-comfort operator's cab (*width: 950 mm*)
- Protective roof grate (*FOPS compliant*)
- Air conditioning system
- Radio and CD player
- Central lubrication system

Optional equipment

- Base carrier**
 - Biodegradable oil
 - Pressurized air conditioning system
- Drilling Equipment**
 - Free fall main winch
 - Swivel for auxiliary rope
 - Videocamera set

The crowd winch system allows the best versatility of use:

- Large clearance under the rotary for casing driving.
- Possibility to extend the drilling range to very large diameters by dismantling the mast lower section.
- Quick conversion from LDP to CFA version.

The double dynamic tensioning avoids rope dangerous overloads.

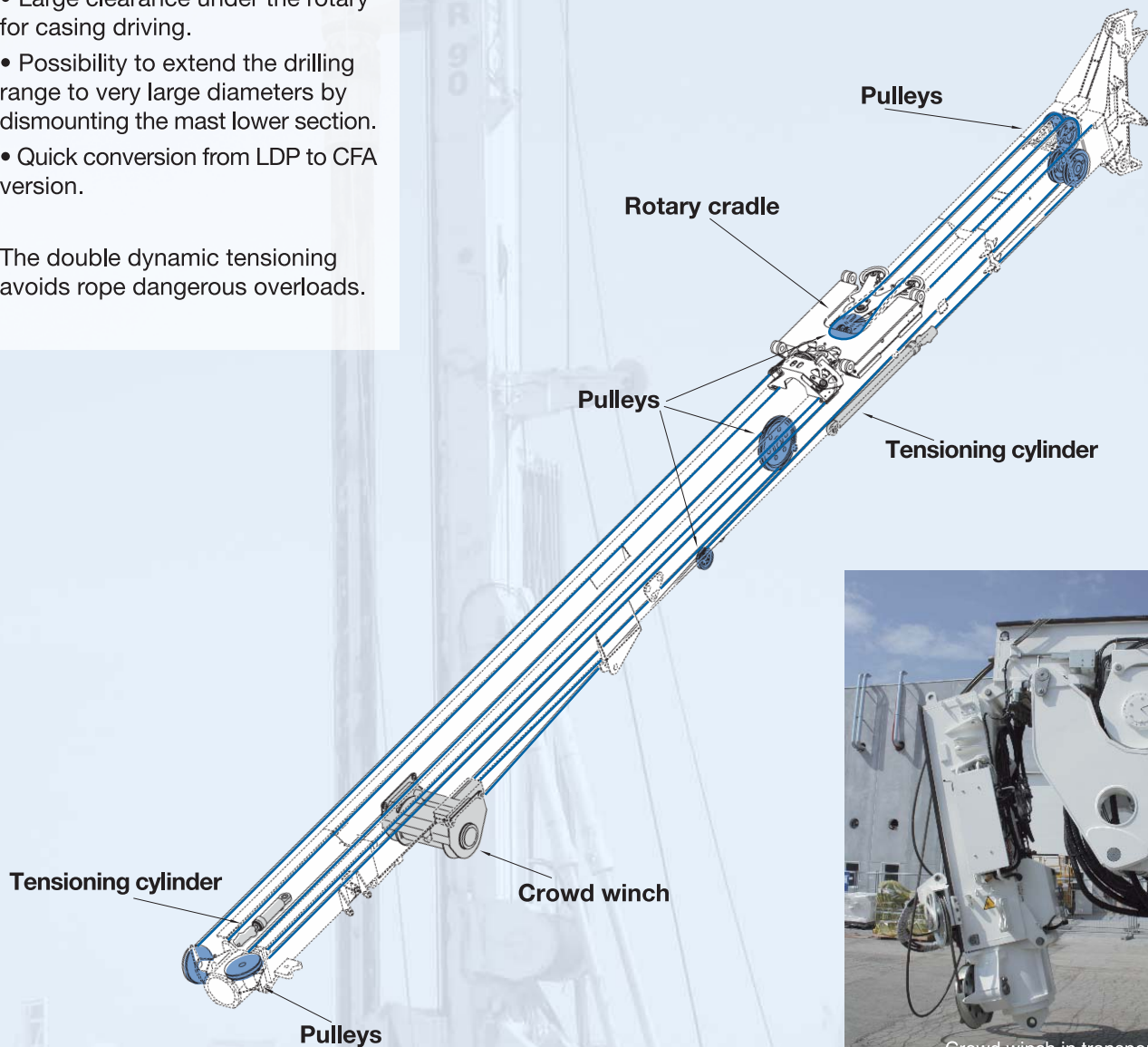

FOCUS - Self erecting counterweight system

The rig is equipped with an autonomous counterweight assembling system which is based on hydraulic cylinders allowing the lifting and the proper adjustment of the counterweight before the final stop. Easy and comfortable lever-operated controls placed on the rig side allow working with maximum visibility and safety.



TRANSPORT DATA

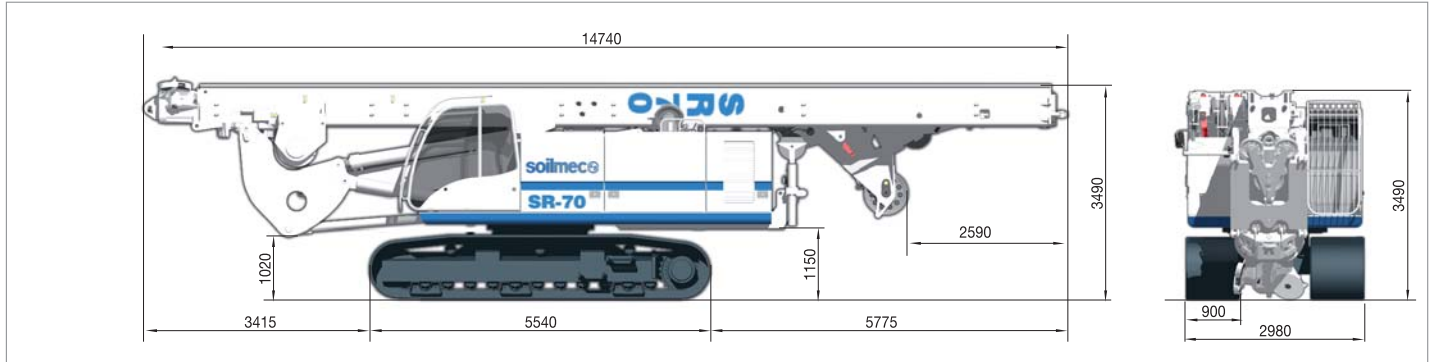

Transport w/o lower mast element

Weight **61900 kg** 136465 lb

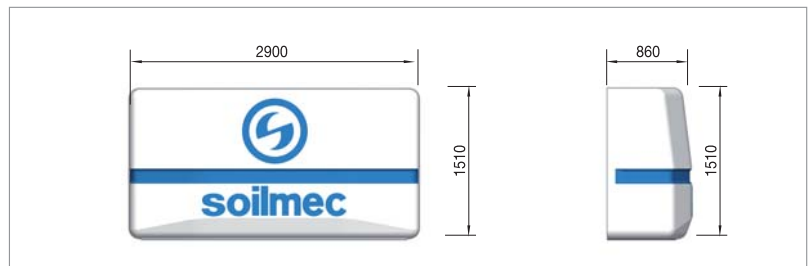

Counterweight

Weight **8500 kg** 18739 lb



DMS

DRILLING MATE SYSTEM

Soilmec innovative DMS - Drilling Mate System - has been designed to incorporate:

- CAN OPEN bus system
- colour touch screen suitable for the drilling field

DMS consists of 3 items:

- DMS
- DMS PC
- DMS MANAGER

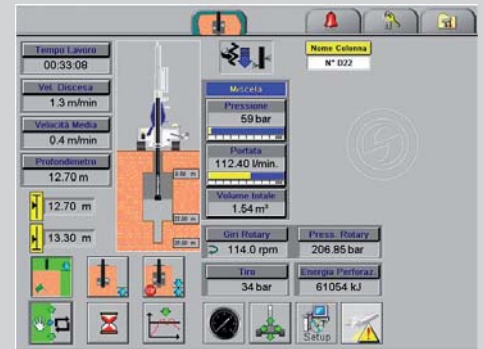

DMS Drilling Mate System

For jet grouting works monitoring, Soilmec micro drilling rigs are provided (on demand) with DMS-jet which is an optional package including sensors to be fitted on the rig, PLC and touch screen.

The system follows the main process parameters:

- drilling depth
- drilling head revolution speed
- drilling head torque
- crowd force
- extraction force
- drilling energy
- feed speed
- hoist speed
- grout pressure
- grout delivery
- air pressure
- air delivery
- working time
- drilling mast position

During the treatment, most significant data are displayed on monitor allowing the driller to operate and follow the consolidation job. For each column, complete data are stored on a USB key. They also can be sent (on driver request) by e-mail in the form of attached file, through the DMS modem, (GSM/GPRS EDGE) to customer office.

DMS send also alarms concerning groups involved in the process.

Data are raw and machine language formatted, they have therefore to be converted for PC use.

DMS PC

DMS PC is soilmec specific software to be installed on customer's PC for raw data conversion. It allows the customer to read, edit and compute the treatment data by means of the most usual softwares.

DMS PC allows editing daily production reports under the form of diagrams and daily report, to document compliance of execution works with job specifications.

DMS PC allows also establishing statistical analysis to follow day by day the job site return.

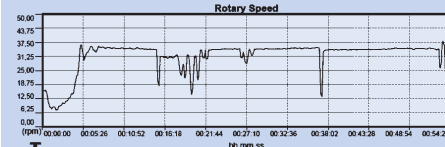
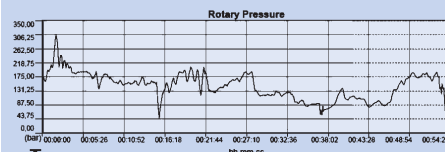
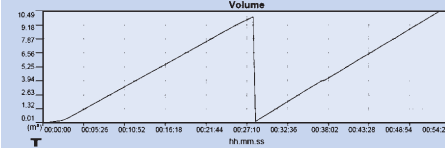
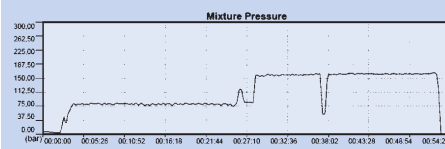

DMS Manager

A system designed for surveying a machines fleet. It includes a dedicated server and software. It enables access to, through internet, permanent contact with the rig, receiving in real time, alarms as well as production data sent by the machines (GPRS modem, satellite).



Spare Part Online Center (SPOC)

Although not specifically engineered for DMS, the package enhances the instrumentation since customers can optimize the management of their rigs.

In fact this online system offers:

- consultation and downloading of rig documentation, e.g. user and maintenance manuals
- electrical/hydraulic drawings, DMS manuals, technical documentation, etc.
- placement and management of purchase orders for spare parts.
- real time availability of components of spare parts.

APPLICATIONS

LDP - Kelly Drilling System

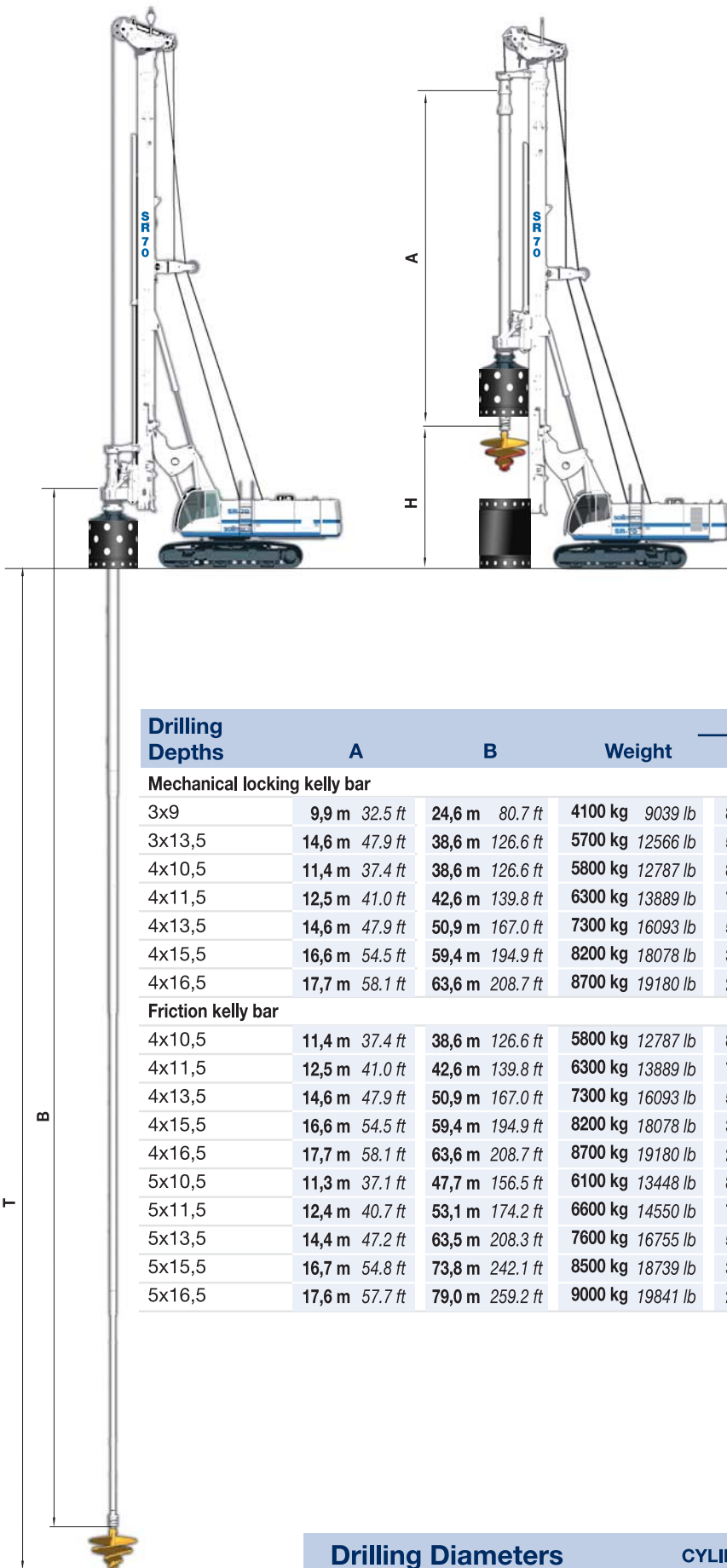

Drilling Depths	A	B	Weight	CYLINDER		WINCH	
				H	T	H	T
Mechanical locking kelly bar							
3x9	9,9 m 32.5 ft	24,6 m 80.7 ft	4100 kg 9039 lb	8,4 m 27.6 ft	23,1 m 75.8 ft	10,3 m 33.8 ft	22,9 m 74.5 ft
3x13,5	14,6 m 47.9 ft	38,6 m 126.6 ft	5700 kg 12566 lb	5,6 m 18.4 ft	37,1 m 121.7 ft	5,6 m 18.4 ft	36,9 m 120.4 ft
4x10,5	11,4 m 37.4 ft	38,6 m 126.6 ft	5800 kg 12787 lb	8,4 m 27.6 ft	37,1 m 121.7 ft	8,8 m 28.9 ft	36,9 m 120.4 ft
4x11,5	12,5 m 41.0 ft	42,6 m 139.8 ft	6300 kg 13889 lb	7,7 m 25.3 ft	41,1 m 134.8 ft	7,7 m 25.3 ft	49,0 m 160.7 ft
4x13,5	14,6 m 47.9 ft	50,9 m 167.0 ft	7300 kg 16093 lb	5,6 m 18.4 ft	49,4 m 162.1 ft	5,6 m 18.4 ft	49,2 m 161.4 ft
4x15,5	16,6 m 54.5 ft	59,4 m 194.9 ft	8200 kg 18078 lb	3,6 m 11.8 ft	57,9 m 190.0 ft	3,6 m 11.8 ft	57,7 m 189.3 ft
4x16,5	17,7 m 58.1 ft	63,6 m 208.7 ft	8700 kg 19180 lb	2,5 m 8.2 ft	62,1 m 203.7 ft	2,5 m 8.2 ft	61,9 m 203.1 ft
Friction kelly bar							
4x10,5	11,4 m 37.4 ft	38,6 m 126.6 ft	5800 kg 12787 lb	8,4 m 27.6 ft	37,1 m 121.7 ft	8,8 m 28.9 ft	36,9 m 121.1 ft
4x11,5	12,5 m 41.0 ft	42,6 m 139.8 ft	6300 kg 13889 lb	7,7 m 25.3 ft	41,1 m 134.8 ft	7,7 m 25.3 ft	40,9 m 134.2 ft
4x13,5	14,6 m 47.9 ft	50,9 m 167.0 ft	7300 kg 16093 lb	5,6 m 18.4 ft	49,4 m 162.1 ft	5,6 m 18.4 ft	49,2 m 161.4 ft
4x15,5	16,6 m 54.5 ft	59,4 m 194.9 ft	8200 kg 18078 lb	3,6 m 11.8 ft	57,9 m 190.0 ft	3,6 m 11.8 ft	57,7 m 189.3 ft
4x16,5	17,7 m 58.1 ft	63,6 m 208.7 ft	8700 kg 19180 lb	2,5 m 8.2 ft	62,1 m 203.7 ft	2,5 m 8.2 ft	61,9 m 203.1 ft
5x10,5	11,3 m 37.1 ft	47,7 m 156.5 ft	6100 kg 13448 lb	8,4 m 27.6 ft	46,2 m 151.6 ft	8,9 m 29.2 ft	46,0 m 150.9 ft
5x11,5	12,4 m 40.7 ft	53,1 m 174.2 ft	6600 kg 14550 lb	7,8 m 25.6 ft	51,6 m 169.3 ft	7,8 m 25.6 ft	51,4 m 168.6 ft
5x13,5	14,4 m 47.2 ft	63,5 m 208.3 ft	7600 kg 16755 lb	5,8 m 19.0 ft	62,0 m 203.4 ft	5,8 m 19.0 ft	61,8 m 202.8 ft
5x15,5	16,7 m 54.8 ft	73,8 m 242.1 ft	8500 kg 18739 lb	3,5 m 11.5 ft	72,3 m 237.2 ft	3,5 m 11.5 ft	72,1 m 236.5 ft
5x16,5	17,6 m 57.7 ft	79,0 m 259.2 ft	9000 kg 19841 lb	2,6 m 8.5 ft	77,5 m 254.3 ft	2,6 m 8.5 ft	77,3 m 253.6 ft

Drilling Diameters	CYLINDER		WINCH	
Uncased	2000 (2500) mm	78.7 (98.4) in	2000 (2500) mm	78.7 (98.4) in
Cased	2000 mm	78.7 in	2000 mm	78.7 in

() removing the mast bottom section

**Quick Conversion Model
combined line pull**

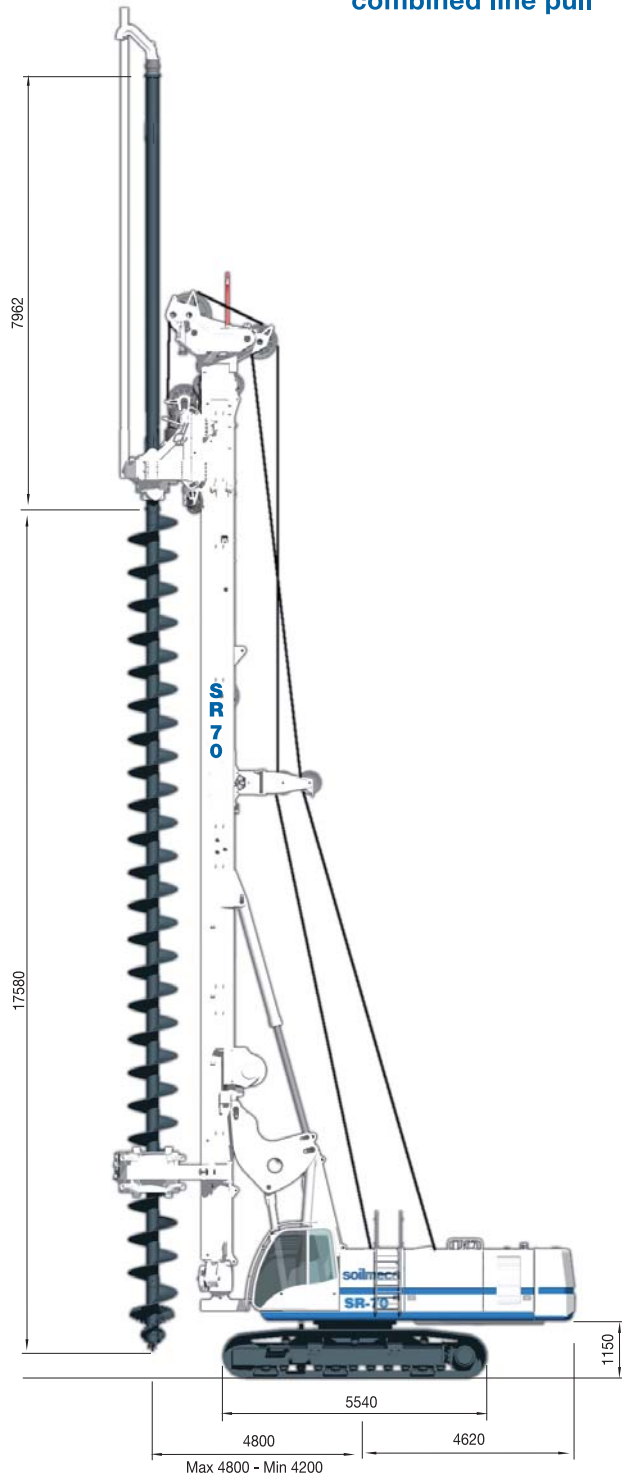

4 - part line pull

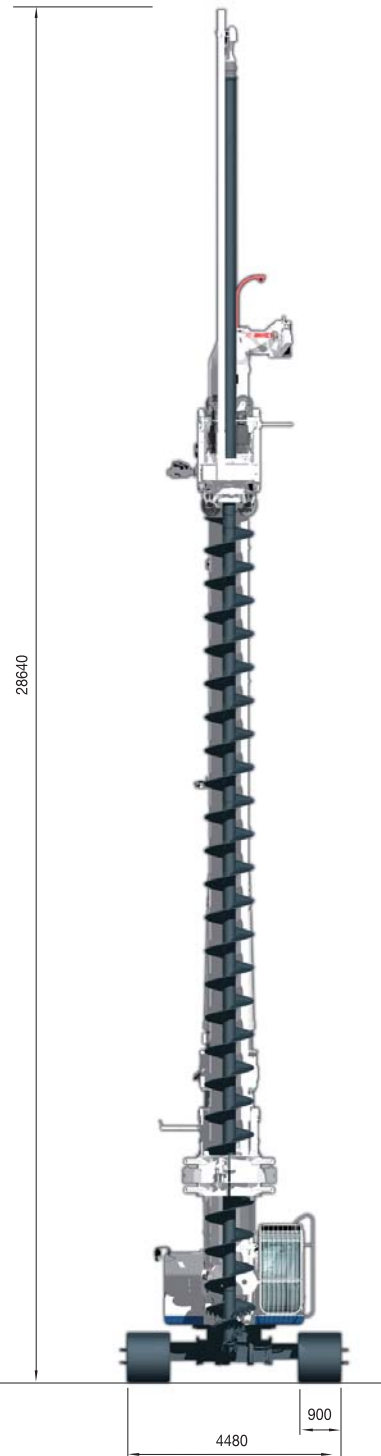

	combined line pull		4-part line pull	
	m	ft	m	ft
Auger extension	8	26.3	6	19.7
Drilling depth with auger cleaner	22 m (14+8)	72.2 ft (45.9+26.3)	25,5 m (19,5+6)	100.1 ft (80.4+19.7)
Drilling depth without auger cleaner	23,5 m (15,5+8)	77.1 ft (50.8+26.3)	27 m (21+6)	95.1 ft (75.4+19.7)
Max drilling diameter	1200 mm	47.2 in	1200 mm	47.2 in
Max extraction force (nominal)	740 kN	166356 lb _f	740 kN	166356 lb _f
Max crowd force (nominal)	320 kN	71938 lb _f	370 kN*	83188 lb _f *
Continuous flight auger length including starter auger	17500 mm	689 in	21000 mm	827 in
Operating weight (approx. w/o augers)	80500 kg	177472 lb	77500 kg	170856 lb

* option: max depth reduced by 1.5 m

APPLICATIONS

CAP - Cased Augered Piles

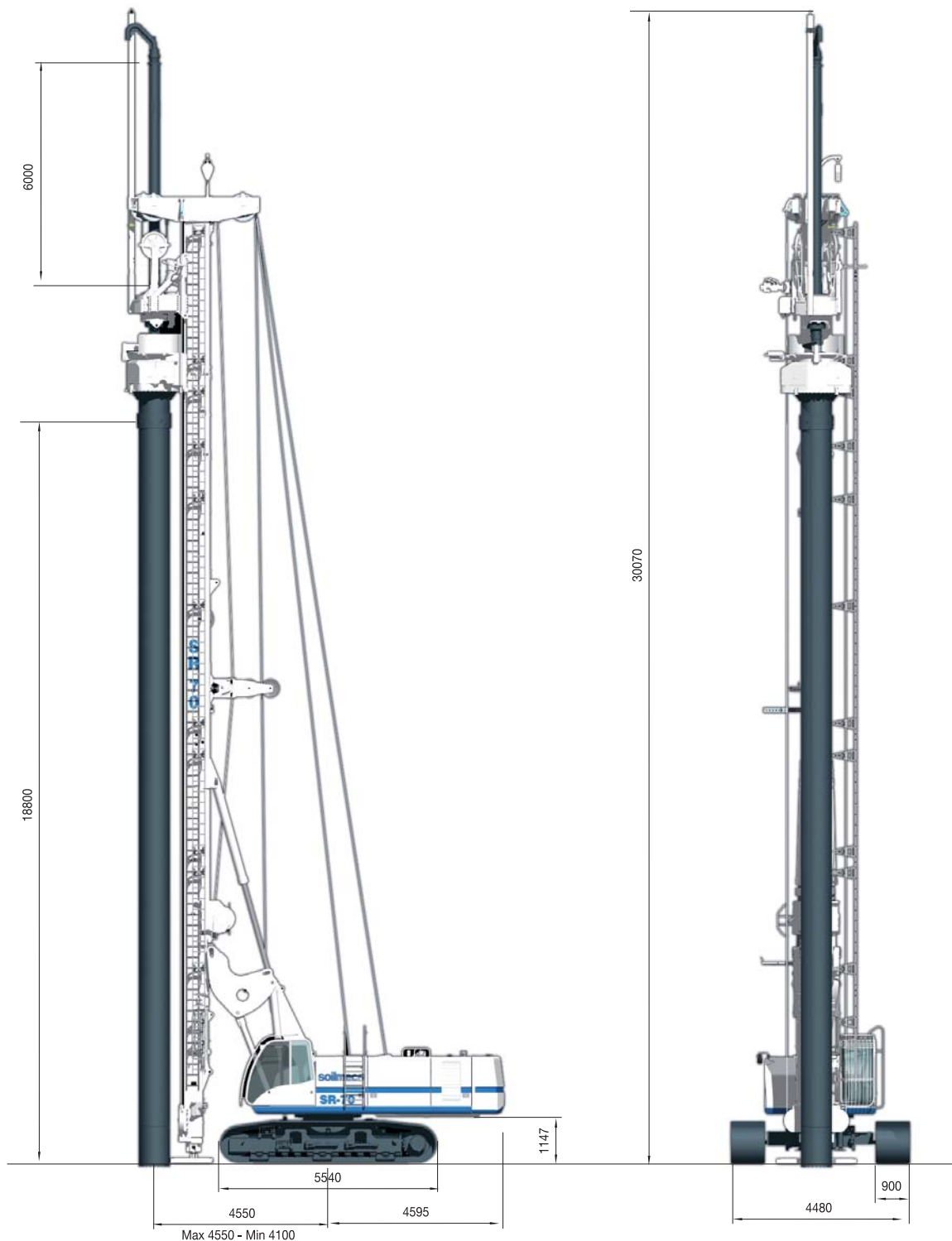

Rotary drive for casing torque (nominal)	189 kNm	<i>119483 lb_f ft</i>
Max speed of casing rotary	19,2 rpm	<i>19.2 rpm</i>
Max drilling diameter	800 mm	<i>31.5 in</i>
Max pile depth	23,5 m	<i>77.1 ft</i>
Max cased depth	17,5 m	<i>57.4 ft</i>
Casing extraction force (nominal)	370 kN	<i>83188 lb_f</i>
Relative movement between rotaries	18860 mm	<i>742.5 in</i>
Operating weight (approx.)	89100 kg	<i>196430 lb</i>

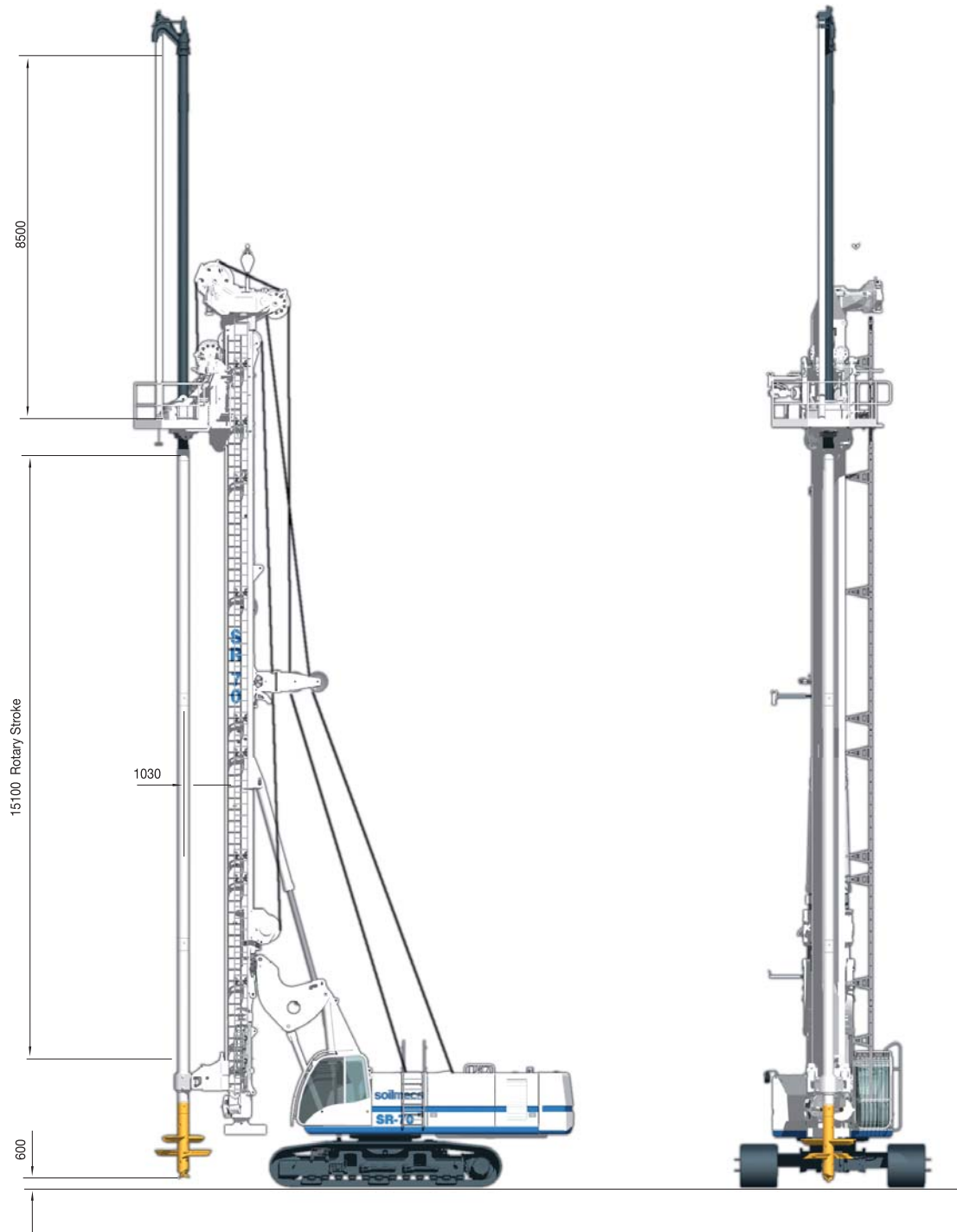

	TJ	
	single	
Extension	8,5 m	27.8 ft
Drilling depth	24,4 m	80 ft
Torque (nominal)	179 kNm	132021 lb _f ft
Speed	43,7 rpm	43.7 rpm
Extraction force (nominal)	940 kN	211317 lb _f
Drilling diameter	1600 mm	63 in
External power pack	-	-
Operating weight (approx.)	109000 kg	240301 lb



SOILMEC distributes machinery and structures all over the world, supported by SOILMEC subsidiary companies and dealers. The complete Soilmec network list is available on the webpage www.soilmec.it