

Lose und in Bandform

Loose and in Bandolier Form

»Firmenprofil« Company Profile

Unsere Produkte:

- Steckverbindersysteme mit Schneidklemm-, Crimp- oder Lötanschluss
- Lötfreie Verbinder
- Crimpkontakte
- Kundenspezifische Sonderentwicklungen
- Verarbeitungs-Systeme für alle STOCKO-Produkte: Handzangen, Halb- und Vollautomaten

Unsere Märkte:

- Hausgerätetechnik
- Heizungstechnik
- Industrie
- Automotive
- Distribution

Gesicherte Qualität

DQS-zertifizierte integrierte Managementsysteme

- Zertifiziert nach ISO 9001 und ISO/TS 16949
STOCKO CONTACT Deutschland, Frankreich
- Zertifiziert nach ISO 14001
STOCKO CONTACT, Frankreich
- Zertifizierungsgesellschaft: DQS GmbH, Frankfurt

Our Products:

- Multi-way connector systems with terminations for insulation displacement crimping or soldering
- Solderless terminals
- Crimp contacts
- Customers' special products
- Terminating systems for all STOCKO products: Hand tools, semi- and fully automated machines

Our Markets:

- Domestic appliances industry
- Heating industry
- Industry
- Automotive
- Distribution

Assured Quality

DQS-certified integrated management systems

- Certified according to ISO 9001 and ISO/TS 16949
STOCKO CONTACT Germany, France
- Certified according to ISO 14001
STOCKO CONTACT, France
- Approval company: DQS GmbH, Frankfurt

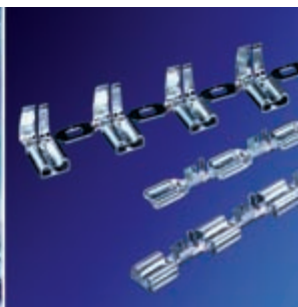

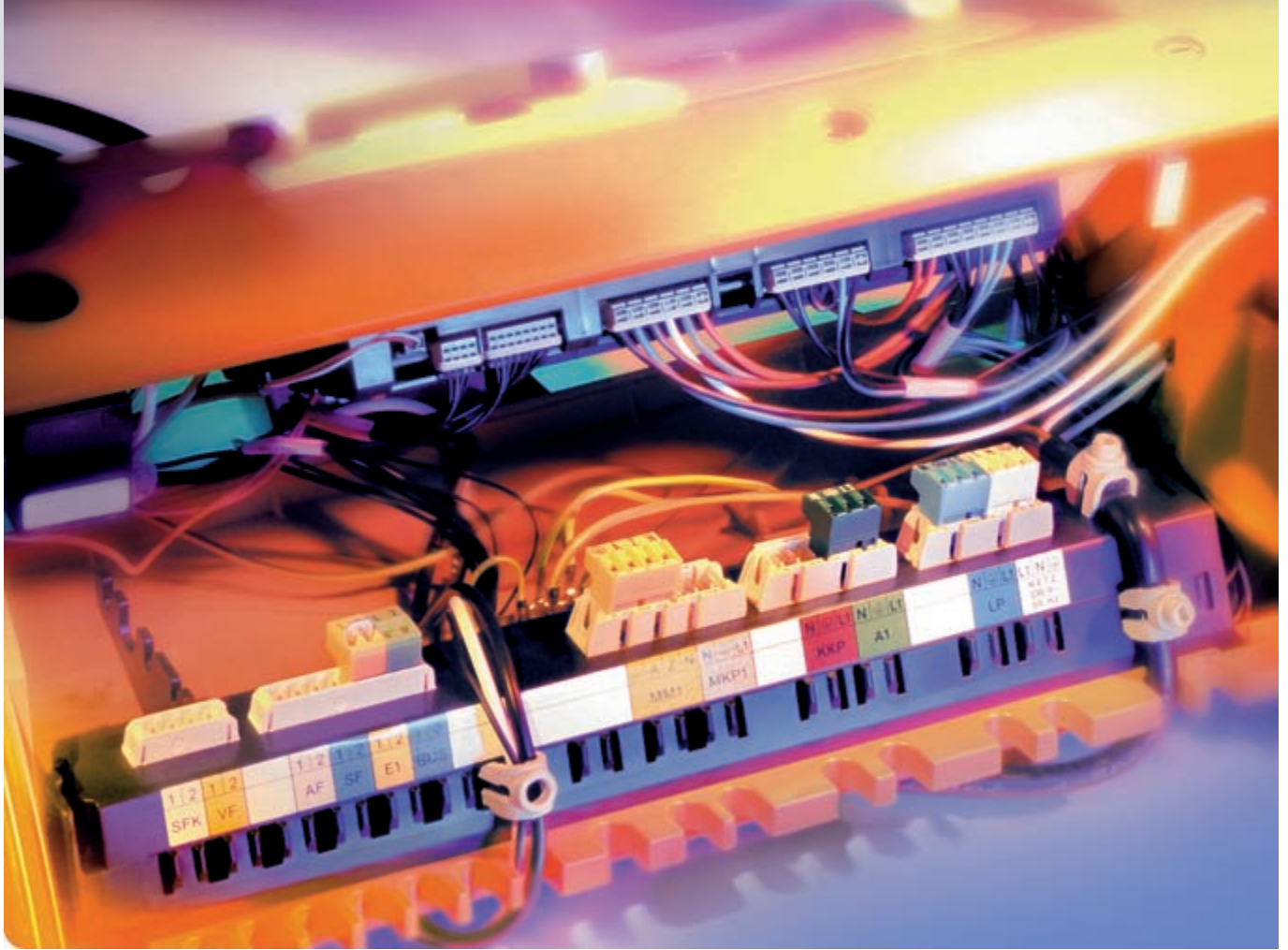

Gründung

- 1901 in Wuppertal

Founded

- 1901 in Wuppertal

Mitarbeiter weltweit

- 450

Employees World-wide

- 450

Werke

- Wuppertal / Deutschland
- Hellenthal / Deutschland
- Andlau / Frankreich
- Sokolov / Tschechien
- Shanghai / China

Factories

- Wuppertal / Germany
- Hellenthal / Germany
- Andlau / France
- Sokolov / Czech Republic
- Shanghai / China



» Sichere Kontakte. Weltweit.« Secure Connections. World-wide.

STOCKO zählt heute zu den führenden europäischen Anbietern von elektromechanischen Bauelementen. Aus gutem Grund. Denn seit mehr als hundert Jahren konzentrieren wir uns bei der täglichen Arbeit auf das Wesentliche: die Zufriedenheit unserer Kunden. Es ist nicht selbstverständlich, über eine so lange Zeit allen Erwartungen gerecht zu werden. Die Bauelementebranche ist eine Schlüsselindustrie, die keine Fehler verzeiht, und die Kundenwünsche so vielfältig wie anspruchsvoll sind. Sie fordern immer wieder unseren ganzen Einsatz – angefangen bei Forschung und Entwicklung, bis hin zu Logistik und Vertrieb. Aus diesem Grund haben wir unsere Kunden von Anfang an in zahlreiche Prozesse, vor allem aber in die Qualitätssicherung eingebunden. Nur so können wir innovative Entwicklungen und Verfahrenstechniken auf den Weg bringen. Und nur so können wir auf Dauer unsere Produkte auf konsequent hohem Niveau anbieten. Produkte, die sich in der Heizungssteuerung und in Getränkeautomaten genauso finden wie im Geschirrspüler oder im Automobil. Wenn wir bei STOCKO also von sicheren Kontakten sprechen, dann deshalb, weil in jedem unserer Steckverbinder die Überzeugung mitschwingt, dass gute Verbindungen immer auch Vertrauenssache sind.

Today, STOCKO is one of the leading European manufacturers of electro-mechanical components; for very good reasons, because, for more than one hundred years, we are focussed in our daily work on the most important object, to satisfy our customers. Of course, it is not easy to meet these expectations over such a long period of time. Electronic component manufacturing is a key industry that does not tolerate mistakes, and customers' requirements are very complex and challenging. Again and again, they demand our full efforts beginning with research and development and finally in logistics and marketing. Hence we invite our customers' involvement in numerous stages of production processes but above all with regard to quality assurance, right from the beginning, and thus make sure that we continue to offer our products at a high quality level. Products that can be found equally in heating controls, drink dispensing machines, dish washers or motor cars. If, at STOCKO, we talk of secure connections then for this reason that in every one of our connectors an element of conviction reverberates that good connections are always a matter of trust.



» Inhalt« Index



	Seite Page		Seite Page
Artikelverzeichnis Index of parts	4 + 5	Sonderanschlußteile Special connectors	54
Technische Informationen Technical informations	6	Isolierkörper Insulation housings	55 - 69
Freigaben Approvals	7 - 9	Verarbeitungstechnik Terminating technology	68 - 70
Vergleichstabellen Cross-reference lists	10 + 11	Crimp-Qualitäts-Übersicht Crimp-quality-chart	71
Flachsteckhülsen Receptacles	12 - 22	Allgemeine Sicherheitshinweise General safety informations	72 - 73
Flachstecker Tabs	23 - 25 / 31 - 35		
Leiterplatten-Kontakte Printed boards contacts	26 - 30		
Krallenkabelschuhe Open barrel terminals	36 - 42		
Aderendhülsen End splices	43 - 48		
Rundsteckhülsen Sockets	49 - 52		
Rundstifte Circular pins	53		

Kundenzeichnungen und technische Datenblätter aller Produkte erhalten Sie auf Anfrage.
Customer drawing and data sheet for all products on request.

Technische Änderungen vorbehalten.
We reserve the right to alter technical details.
WEEE-Reg.-Nr. DE 14484959

Artikelverzeichnis Index of parts



Spulen / Spools Ø: 286 mm / 360 mm



Spulen / Spools Ø: 500 mm



Spulen / Spools Ø: 595 mm



Spulen / Spools Ø: 600 mm / 640 mm

Artikel-Nummer Part number	Spulen Ø Spools Ø mm	Seite Page
-------------------------------	----------------------------	---------------

600		
649 / -G		55
650.100 / -G		55
657.100 / -G		55
658.100 / -G		56
678.100 / -G		56
679.200 / -G		56
680 / -G		57
681 / -G		55
683.002 / -G		56
688-002		59
688-003		59
688-004		59
688-005		59
688-006		59
688-007		59
688-008		59
688.400-002		59
688.400-003		59
688.400-004		59
688.400-005		59
688.400-006		59
688.400-007		59
688.400-008		59
694 / -G		57
695 / -G		58
699-002		60
699-003		60
699-004		60
699-005		60
699-006		60
699-007		60
699-008		60

700		
700/4		58
701 / -G		61
718.100		62
727.001		61
727.002		61
728		61
798-003-025-960 / -G		60
798-005-020-960		60

2000		
2023.100 / -G		62
2023.200 / -G		62
2025.100 / -G		63
2025.200 / -G		63
2026.100 / -G		65
2026.200 / -G		65
2027.100 / -G		64
2027.200 / -G		64
2028.100 / -G		65
2028.110 / -G		66
2028.200 / -G		66
2028.300		65
2029		67
2029.100		67

Artikel-Nummer Part number	Spulen Ø Spools Ø mm	Seite Page
-------------------------------	----------------------------	---------------

2029.200		67
2041.100 / -G		64
2041.200 / -G		64

5000		
5889		25

5900		
5920.003	360	28
5920.004	360	28
5980.001		30

6000		
6006	500	30
6006.002	500	30
6006.100	500	30
6007.002	500	30
6007.003	500	30
6008	500	29
6008.001	500	29
6008.002	500	29
6008.003	500	29
6015		34
6015 VS		31
6015.001		31
6015.002		32
6015.003		32
6015.045		34
6015.090		34
6015.145		32
6015.190		32
6015.245		31
6015.290		31
6015.345		31
6015.390		32
6015.445		32
6015.490		31
6015.545		32
6015.590		32
6015.645		31
6015.690		31
6015.745		32
6015.790		32
6015.845		31
6015.890		31

6044		28
6044.001		28
6045		29
6059		33
6059.645		33
6059.690		33
6080		33
6080.045		33
6080.090		33

6100		
6129		35
6129/2		35
6129.045		35

Artikel-Nummer Part number	Spulen Ø Spools Ø mm	Seite Page
-------------------------------	----------------------------	---------------

6129.045/3		35
6129.075/2		35
6129.090		35
6129.090/2		35
6129.090/3		35
6198	360	28
6198.001	360	28
6199	360	28

6200		
6201	500	30

7200		
7206	286	37
7207	286	37
7208	286	38
7209	286	38

7600		
7601.030	286	20
7603.028	286	15
7603.105	286	15
7603.108	286	15
7604.255	286	15
7604.258	286	15
7605	286	12
7605.001	286	12
7606	286	12
7606.001	286	12
7607	286	12
7607.001	286	12
7630	600	19
7630.001	600	19
7631	600	19
7631.001	600	19

7700		
7716.001	286	37
7716.002	286	40
7727	286	36
7728.002	360	39
7735.001	286	45
7737.001	286	36
7738	286	42
7752	286	46
7755.001	286	14
7755.002	286	14
7770	286	46
7771	286	46
7779	286	36
7785	286	12
7785.001	286	12
7785.002	286	12
7785.003	286	12
7785.055	286	12
7785.058	286	12
7786	286	49
7786.001	286	49
7786.004	286	50

Artikelverzeichnis Index of parts

Artikel-Nummer Part number	Spulen Ø Spools Ø mm	Seite Page
7786.005	286	49
7788	360	39
7788.001	360	40
7791	286	45
7791.001	286	45
7792.002	286	43
7800		
7806	286	47
7813	286	37
7825.001	286	43
7830	286	42
7830.001	286	42
7831.010	286	25
7831.011	286	25
7832	286	46
7833.010	286	25
7833.011	286	25
7835	286	53
7836	286	51
7836.003	286	51
7837	286	45
7838	286	43
7840	286	25
7841	286	25
7843	286	42
7843.001	286	42
7849	286	44
7854.001	286	49
7858	286	19
7858.001	286	19
7860.001	600	49
7861.001	600	53
7861.002	600	53
7861.003	600	53
7869	286	50
7877	286	38
7881	286	37
7881.001	286	40
7884.001	360	48
7884.003	360	48
7884.004	360	48
7894	286	45
7897.001	286	49

Artikel-Nummer Part number	Spulen Ø Spools Ø mm	Seite Page
7900		
7900	286	18
7901	286	18
7908	286	44
7912	286	45
7916	286	19
7916.001	286	19
7918.001	600	26
7918.002	600	26
7921	286	36
7923.002	286	41
7926	286	32
7929	286	44
7930	286	23
7936.002	286	15
7936.003	286	15
7942	286	31
7944.010	286	18
7944.258	286	18
7957	286	49
7957.002	286	50
7958	286	23
7960.020	286	22
7961.020	286	22
7975	600	52
7979	600	18
7979.001	600	18
7979.002	600	18
7984	600	15
7984.001	600	15
7990	286	13
7990.001	286	13
7990.055	286	13
7990.058	286	13
7994.002	640	50
7994.003	640	50
7995.003	286	51
7995.004	286	51
7995.005	286	51
7999	286	44
8000		
8000	286	49
8006	286	45
8007.001	600	54
8011	286	46

Artikel-Nummer Part number	Spulen Ø Spools Ø mm	Seite Page
8014	286	26
8028	286	17
8028.001	286	17
8028.002	286	17
8028.003	286	17
8029	286	17
8029.001	286	17
8029.2258	286	17
8037	640	53
8037.001	640	53
8037.002	640	53
8039.001	286	23
8039.003	286	23
8043	286	24
8044	360	39
8044.001	360	40
8047	286	22
8048	286	22
8053	286	27
8055	600	26
8059	640	43
8061	600	47
8064	286	15
8068	600	20
8069	286	52
8069.001	286	52
8069.002	286	52
8083	600	27
8100		
8100	286	13
8100.001	286	13
8100.002	286	13
8100.003	286	13
8100.2055	286	13
8100.2058	286	13
8110	286	51
8110.001	286	51
8113.105	600	13
8113.108	600	13
8113.155	600	13
8115	286	18
8121.020	286	52
8121.022	286	52
8121.025	286	52
8121.115	286	52

Artikel-Nummer Part number	Spulen Ø Spools Ø mm	Seite Page
8126.010	286	22
8131	286	48
8134.010	286	41
8136	286	21
8137	286	21
8138	286	18
8138.108	286	18
8152	286	18
8165.108	286	24
8168.055	286	16
8168.058	286	16
8168.155	286	16
8168.158	286	16
8170.055	286	16
8170.058	286	16
8170.155	286	16
8170.158	286	16
8178.108	286	22
8178.258	286	22
8178.308	286	22
8180.1158	286	21
8185	600	52
8186.155	286	16
8186.158	286	16
8200		
8200	360	39
8201	360	39
8202	360	37
8203	360	38
8204	360	38
8205.1158	286	23
8236	286	43
8238.158	286	21
8238.258	286	21
8239	286	54
8240.158	286	21
8240.258	286	21
8240.1158	286	21
8260.155	286	20
8260.158	286	20
8260.258	286	20
8280.1055	286	14
8280.1058	286	14
8280.1105	286	14
8280.1108	286	14

Abspulrichtung
für Quertransport

Direction of transverse
transport

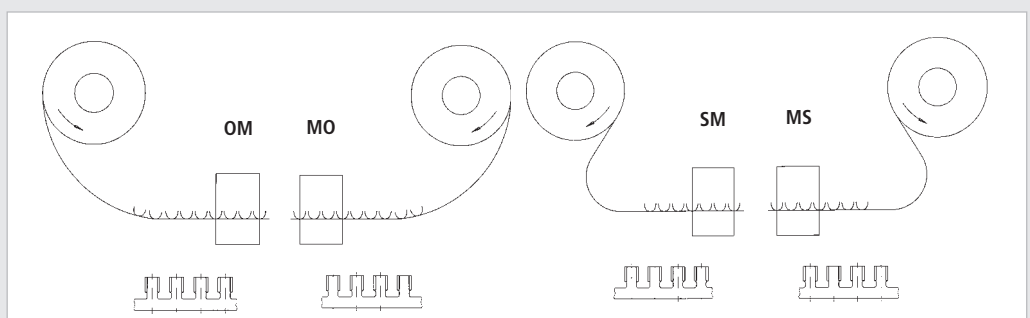

Technische Informationen Technical Informations

Werkstoffe und Oberflächen

Die eingesetzten Werkstoffe bestimmen das Verhalten und die Eigenschaften der Kontakte. Festigkeit, Federeigenschaften, elektrische Leitfähigkeit und Temperaturverhalten sind wesentliche Kriterien bei der Bewertung der Anwendungen. Messing, Zinnbronze und Stahl sind die gebräuchlichsten Grundmaterialien. Verschiedene Oberflächenbehandlungen erweitern den Anwendungsbereich bei speziellen Anforderungen. Sondermaterialien (z. B. Neusilber) auf Anfrage.

Werkstoff	Zulässige Grenztemperatur	Anwendungsbereich
Messing (CuZn) blank verzinkt (Sn) versilbert (Ag)	110 °C 120 °C 130 °C	Nur für günstige Umgebungsbedingungen, Korrosionsanfällig. Verzinkte Komponenten ergeben gute Leistungen bei höheren Temperaturen und schützen vor Korrosion. Versilberte Komponenten eignen sich für höchste Betriebstemperaturen bei höherer Strombelastung für Messing.
Zinnbronze (CuSn) blank verzinkt (Sn) versilbert (Ag)	120 °C 130 °C 150 °C	Unter korrosiven Bedingungen stabiler als Messing. Verzinkte Komponenten ergeben bei höheren Temperaturen verbesserten Korrosionsschutz. Versilberte Komponenten eignen sich für höchste Betriebstemperaturen bei höherer Strombelastung für Zinnbronze.
Neusilber (CuNiZn) blank	210 °C	Gute Korrosionsbeständigkeit. Erhöhte Festigkeit gegenüber Messing. Hoher elektrischer Widerstand, geringe Wärmeleitfähigkeit.
Stahl (Fe) vernickelt (Ni)	300 °C	Vernickelte Stahlkomponenten ergeben beste zuverlässige Verbindungen bei höheren Temperaturen.

Materials and surface finishes

The materials used determine the performance and properties of the contacts. Strength, elasticity, electric conductivity and thermal performance are major criteria when it comes to rating different applications.

Brass, phosphor bronze and steel are the most common base materials. Different surface finishes extend the application range for specific requirements. Special materials (e. g. nickel silver) on request.

Material	Max. temperature	Application range
Brass (CuZn) unplated tin plated (Sn) silver plated (Ag)	110 °C 120 °C 130 °C	Only for favourable environmental conditions. Susceptible to corrosion. Tin plated components perform well at higher temperatures and are resistant to corrosion. Silver plated components are suitable for highest operating temperatures coupled with higher current loads for brass.
Phosphor bronze (CuSn) unplated tin plated (Sn) silver plated (Ag)	120 °C 130 °C 150 °C	Under corrosive conditions more stable than brass. Tin plated components offer improved resistance to corrosion at higher temperatures. Silver plated components are suitable for highest operating temperatures coupled with higher current loads for tin bronze.
Nickel silver (CuNiZn) unplated	210 °C	Good resistance to corrosion. Stronger than brass. High electric resistance, low thermal conductivity.
Steel (Fe) nickel plated (Ni)	300 °C	Nickel plated steel components produce the most reliable connections at higher temperatures.

Werkstoffdaten für Isolierkörper Material data for insulation housings

Werkstoff Material	Temperatur Index nach UL, Details siehe UL-Listing Temperature index acc. to UL, details see UL list
PA 66-V2	- 40 °C + 130 °C
PA 6/66-V0	- 40 °C + 140 °C
PA 46-V2	- 40 °C + 150 °C
PA 6-V2 nach / according to IEC 60335 (auf Anfrage / on request)	- 40 °C + 130 °C
PPS V0 nach / according to IEC 60335	- 40 °C + 240 °C
PBT V0	- 40 °C + 130 °C

Freigaben Approvals

VDE-geprüfte Crimpkontakte VDE tested crimp contacts

Artikel- Nummer Part number	CuZn blank unplated	CuZn verzinnt tin plated	CuSn blank unplated	CuSn verzinnt tin plated	Fe vernickelt nickel plated	CuNiSi blank unplated	CuNiSi verzinnt tin plated	CuNiZn blank unplated
RSB 7604.258					•			
RMB 7840		•						
RMB 7831.010		•						
RSB 7900	•							
RSB 7944.010	•	•	•	•	•		•	
RSB 7960.020	•	•						
RSB 7961.020	•	•						
RFB 7979		•						
RSB 8028		•						•
RSB 8047	•	•	•	•				
RSB 8048	•	•	•	•				
RBB 8110	•				•			
RFB 8121.020					•			
RFB 8121.025					•			
RSB 8138.108	•	•			•			
RSB 8165.108		•						
RSB 8168.055	•	•						
RSB 8168.058	•	•						
RSB 8168.155	•	•						
RSB 8168.158	•	•						
RSB 8170.055	•	•			•			
RSB 8170.058	•	•			•			
RSB 8170.155	•	•			•			
RSB 8170.158	•	•			•			
RSB 8178.108	•	•						•
RSB 8178.258	•	•						•
RSB 8180.1158					•			
RSB 8186.155	•	•			•			
RSB 8186.158	•	•			•			
RSB 8240.158	•	•			•			
RSB 8240.258	•	•			•			
RSB 8240.1158					•			
RSB 8260.158	•	•			•			
RSB 8260.258	•	•			•			

STOCKO-Produkte werden in unseren Prüflaboratorien laufend vielfältigen Prüfungen unterzogen. VDE-, UL- und weitere Freigaben für die wichtigen STOCKO-Artikel werden regelmäßig ergänzt. UL-Freigaben und eine einwandfreie Verkrimpfung unserer Produkte sind nur dann gewährleistet, wenn die Verarbeitung auf STOCKO-Werkzeugen erfolgt.

STOCKO products are fully tested at our laboratories. VDE, UL and other approvals for the main STOCKO items are regularly updated. UL approvals and correct crimping only ensured on products crimped with STOCKO applicators.

UL / ULC-Freigabeübersicht für Crimpkontakte Index UL / ULC approvals for crimp contacts

Artikel-Nummer Part number	CuZn blank unplated	CuZn verzinnt tin plated	CuSn blank unplated	CuSn verzinnt tin plated	Fe vernickelt nickel plated	CuNiSi blank unplated	CuNiSi verzinnt tin plated	UL File
RSB 7605	•	•						E118944
RSB 7605.001	•	•						E118944
RSB 7606.001	•	•						E118944
RSB 7607	•							E118944
RSB 7630	•	•	•	•	•			E118944
RSB 7630.001	•	•	•		•			E118944
RSB 7631	•	•	•		•			E118944
RSB 7631.001	•	•	•		•			E118944

Freigaben Approvals

UL / ULC-Freigabeübersicht für Crimpkontakte

Index UL / ULC approvals for crimp contacts

Artikel-Nummer Part number	CuZn blank unplated	CuZn verzinkt tin plated	CuSn blank unplated	CuSn verzinkt tin plated	Fe vernickelt nickel plated	CuNiSi blank unplated	CuNiSi verzinkt tin plated	CuNiZn	UL File
RSB 7785	●	●	●		●				E118944
RSB 7785.001	●	●			●				E118944
RSB 7785.002	●	●			●				E118944
RSB 7785.003	●	●			●				E118944
RSB 7785.055	●	●			●				E118944
RSB 7785.058	●	●			●				E118944
RSB 7788	●	●	●	●					E177431
RSB 7792.002	●	●			●				E177431
RMB 7831.010	●	●	●						E118944
RMB 7831.011	●	●	●						E118944
RSB 7832	●	●							E177431
RMB 7833.010	●	●	●						E118944
RMB 7833.011	●	●	●						E118944
RSB 7849	●	●			●				E177431
RSB 7858	●	●							E118944
RSB 7858.001	●	●							E118944
RSB 7894	●	●							E177431
RSB 7900	●	●	●	●	●				E118944
RSB 7901	●	●	●	●	●				E118944
RSB 7923.002	●	●	●	●	●				E177431
RSB 7944.010	●	●	●	●	●		●		E118944
RSB 7944.258	●	●							E118944
RMB 7958	●	●							E118944
RSB 7960.020	●	●	●	●				●	E118944
RSB 7961.020	●	●	●						E118944
RFB 7979			●	●					E118944
RFB 7979.001				●					E118944
RSB 7984	●	●			●				E118944
RSB 7990	●	●							E118944
RSB 7990.001	●	●							E118944
RBB 7995.003					● (X5CrNi)				E118944
RSB 8028	●	●							E118944
RSB 8028.001	●	●							E118944
RSB 8029	●	●							E118944
RSB 8029.001	●	●							E118944
RSB 8047	●	●							E118944
RSB 8100.2055	●				●				E118944
RFB 8121.020					●				E118944
RFB 8121.025					●				E118944
RSB 8126.010	●	●	●	●					E118944
RSB 8138	●	●	●	●	●				E118944
RSB 8152				●	●				E118944
RMB 8165.108	●	●							E118944
RSB 8168.055	●	●							E118944
RSB 8168.058	●	●							E118944
RSB 8168.155	●	●							E118944
RSB 8168.158	●	●							E118944
RSB 8170.055	●	●			●				E118944
RSB 8170.058	●	●			●				E118944
RSB 8170.155	●	●			●				E118944
RSB 8170.158	●	●			●				E118944
RSB 8178.108	●	●							E118944
RSB 8178.258	●	●							E118944
RSB 8178.308	●	●							E118944
RSB 8186.155	●	●			●				E118944
RSB 8186.158	●	●			●				E118944
RSB 8238.158	●	●			●				E118944
RSB 8238.258	●	●			●				E118944
RSB 8240.158	●	●			●				E118944
RSB 8240.258	●	●			●				E118944
RSB 8260.158	●	●	●	●	●				E118944
RSB 8260.258	●	●	●	●	●				E118944

Freigaben Approvals

VDE-Freigabeübersicht für Isolierkörper

Index VDE approvals for insulation housings

Artikel-Nummer Part number	Farbe Colour	Material Material	Brennbarkeitsklasse Flammability class		Material Material	Brennbarkeitsklasse nach Flammability class to V2 IEC 60335 no flame	UL File
			V0	V2			
EH 688-00X	natur	PA 66	●		PA 6	●	
EH 688.400-00X	Farben auf Anfrage	PA 66	●		PA 6	●	
EH 694		PA 66	●	●	PA 6		
EH 695	natural	PA 66	●	●	PA 6	●	
EH 699	colors on request				PA 6	●	
EH 718.100					PA 6	●	
EH 700	schwarz, black	PPS	●				

UL-Freigabeübersicht für Isolierkörper

Index UL approvals for insulation housings

EH 649		PA 66	●	●	PA 6	●	E306845
EH 650.100		PA 66	●	●	PA 6	●	E306845
EH 650.200		PA 66	●	●	PA 6	●	E306845
EH 657.100		PA 66	●	●	PA 6	●	E306845
EH 658.100		PA 66		●	PA 6	●	E306845
EH 678.100		PA 66		●	PA 6	●	E306845
EH 679.200		PA 66	●	●	PA 6	●	E306845
EH 680		PA 66	●	●	PA 6	●	E306845
EH 681		PA 66	●	●	PA 6	●	E306845
EH 683.002		PA 66	●	●	PA 6	●	E306845
EH 688-00X	natur	PA 66	●		PA 6	●	E306640
EH 688.400-00X	Farben auf Anfrage	PA 66	●		PA 6	●	E306640
EH 694		PA 66	●	●	PA 6		E191950
EH 695	natural	PA 66	●	●	PA 6	●	E306845
EH 701	colors on request	PA 66		●	PA 6	●	E306845
EH 718.100					PA 6	●	E306640
EH 798.003					PA 6	●	E306845
EH 798.005		PA 66	●				E306845
VV 2023.100		PA 66	●	●	PA 6	●	E306845
VV 2023.200		PA 66	●	●	PA 6	●	E306845
VV 2025.100		PA 66		●	PA 6	●	E306845
VV 2025.200		PA 66		●	PA 6	●	E306845
VV 2026.100		PA 66		●	PA 6	●	E306845
VV 2026.200		PA 66		●	PA 6	●	E306845
VV 2027.100		PA 66		●	PA 6	●	E306845
VV 2027.200		PA 66		●	PA 6	●	E306845
VV 2028.100		PA 66		●	PA 6	●	E306845
VV 2028.110		PA 66		●	PA 6	●	E306845
VV 2028.200		PA 66		●	PA 6	●	E306845
VV 2029.100		PA 66		●	PA 6	●	E306845
VV 2029.200		PA 66		●	PA 6	●	E306845
VV 2041.100		PA 66		●	PA 6	●	E306845
VV 2041.200		PA 66		●	PA 6	●	E306845

STOCKO-Produkte werden in unseren Prüflaboratorien laufend vielfältigen Prüfungen unterzogen. VDE-, UL- und weitere Freigaben für die wichtigen STOCKO-Artikel werden regelmäßig ergänzt.

STOCKO products are fully tested at our laboratories. VDE, UL and other approvals for the main STOCKO items are regularly updated. UL approvals and correct crimping only ensured on products crimped with STOCKO applicators.

Vergleichstabellen Cross-reference lists

Umrechnung des Inch Equivalents of an Inch

Übersicht der gängigen Leiter nach VDE 0250 / 4.64

Cable chart of wire sizes to VDE 0250 / 4.64 spification

Fraction inch	Decimal inch	Millimeter mm
1/64	.015625	0.397
1/32	.031250	0.794
3/64	.046875	1.191
1/16	.062500	1.588
5/64	.078125	1.984
3/32	.093750	2.381
7/64	.109375	2.778
1/8	.125000	3.175
9/64	.140625	3.572
5/32	.156250	3.969
11/64	.171875	4.366
3/16	.187500	4.763
13/64	.203125	5.159
7/32	.218750	5.556
15/64	.234375	5.953
1/4	.250000	6.350
17/64	.265625	6.747
9/32	.281250	7.144
19/64	.296875	7.541
5/16	.312500	7.938
21/64	.328125	8.334
11/32	.343750	8.731
23/64	.359375	9.128
3/8	.375000	9.525
25/64	.390625	9.922
13/32	.406250	10.319
27/64	.421875	10.716
7/16	.437500	11.113
29/64	.453125	11.509
15/32	.468750	11.906
31/64	.484375	12.303
1/2	.500000	12.700
33/64	.515625	13.097
17/32	.531250	13.494
35/64	.546875	13.891
9/16	.562500	14.288
37/64	.578125	14.684
19/32	.593750	15.081
39/64	.609375	15.478
5/8	.625000	15.875
41/64	.640625	16.272
21/32	.656250	16.669
43/64	.671875	17.066
11/16	.687500	17.463
45/64	.703125	17.859
23/32	.718750	18.256
47/64	.734375	18.653
3/4	.750000	19.050
49/64	.765625	19.447
25/32	.781250	19.844
51/64	.796875	20.241
13/16	.812500	20.638
53/64	.828125	21.034
27/32	.843750	21.431
55/64	.859375	21.828
7/8	.875000	22.225
57/64	.890625	22.622
29/32	.906250	23.019
59/64	.921875	23.416
15/16	.937500	23.813
61/64	.953125	24.209
31/32	.968750	24.606
63/64	.984375	25.003
1	1.000000	25.400

mm ²	Anzahl und Ø der Leiterdrähte No. and dia. of strands mm	Leiter-Ø Wire dia. mm max.
0,5	1 x 0,80	0,8
	7 x 0,30	0,9
	16 x 0,20	0,9
0,75	1 x 1,00	1,0
	7 x 0,37	1,1
	24 x 0,20	1,2
1	1 x 1,13	1,13
	7 x 0,43	1,3
	19 x 0,25	1,3
	32 x 0,20	1,3
1,5	1 x 1,38	1,38
	7 x 0,52	1,6
	21 x 0,30	1,6
	30 x 0,25	1,7
2,5	189 x 0,10	1,9
	1 x 1,78	1,78
	7 x 0,67	2,1
	35 x 0,30	2,2
4	50 x 0,25	2,2
	315 x 0,10	2,2
	1 x 2,26	2,26
	19 x 0,52	2,7
6	56 x 0,30	3,1
	511 x 0,10	3,0
	1 x 2,76	2,76
	7 x 1,05	3,2
10	19 x 0,64	3,3
	84 x 0,30	3,5
	756 x 0,10	3,7
	1 x 3,57	3,57
16	7 x 1,35	4,1
	19 x 0,80	4,3
	49 x 0,51	4,6
	80 x 0,40	5,0
25	1197 x 0,10	4,5
	1 x 4,52	4,52
	7 x 1,70	5,2
	37 x 0,75	5,6
	49 x 0,65	5,9
	128 x 0,40	6,0
2058 x 0,10	6,8	

Vergleichstabellen Cross-reference lists

Umrechnung der gängigen amerikanischen Leiter

Conversion table of American Wire Sizes

AWG #	Circ. Mils.	A = mm ²
26	238 - 300	0,12 - 0,15
24	315 - 477	0,16 - 0,24
22	600 - 750	0,30 - 0,38
20	1000 - 1200	0,51 - 0,61
18	1600 - 1900	0,81 - 0,96
16	2400 - 2830	1,22 - 1,43
14	3830 - 4500	1,94 - 2,28
12	6100 - 6700	3,09 - 3,40
10	9000 - 13100	4,56 - 6,64
8	13200 - 16900	6,69 - 8,56
6	22800 - 30900	11,55 - 15,66

AWG #	Circ. Mils.	A = mm ²
4	38900 - 49100	19,71 - 24,88
2	60100 - 66800	30,45 - 33,85
1	75800 - 84000	38,41 - 42,56
1/0	99100 - 105800	50,21 - 53,61
2/0	124900 - 133800	63,29 - 67,80
3/0	157600 - 168000	79,86 - 85,12
4/0	198700 - 212200	100,68 - 107,52
250 - 300 MCM	250000 - 300000	117 - 151
300 - 350 MCM	300000 - 350000	151 - 192
400 MCM	400000	205
500 - 600 MCM	500000 - 600000	252 - 304

AWG = American Wire Gauge

Circ. Mils.: Der Circ. Mils.-Wert eines Kreises mit d = 1 Mil. beträgt:
 $1 \times 1 = 1$ Circ. Mil. (1 Mil. = 0,001 inch = 0,0254 mm)
 1 Circ. Mil. = 0,0005066 mm²
 1 mm² = 1973,51 Circ. Mils.

Formel zur Bestimmung des Leiterquerschnittes

$$A = \frac{d^2 \cdot p}{4} \times n$$

A = Leiterquerschnitt in mm²
n = Anzahl Einzeldrähte

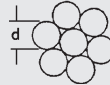

AWG = American Wire Gauge

Circular Mil Area (CMA): Area of a circle of 1 mil diameter
 $1 \times 1 = 1$ Circ. Mil. (1 Mil. = 0.001 inch = 0.0254 mm)
 1 Circ. Mil. = 0.0005066 mm²
 1 mm² = 1973.51 Circ. Mils.

Formula to determine the wire size

$$A = \frac{d^2 \cdot p}{4} \times n$$

A = Wire size in mm²
n = Number of strands



Anschlußbolzen Standard stud-bolts

DIN	USA	British Assoc.
M 2	1 = 1,9 mm	9 BA = 1,9 mm
	2 = 2,2 mm	8 BA = 2,2 mm
M 2,6	3 = 2,5 mm	7 BA = 2,5 mm
	4 = 2,8 mm	6 BA = 2,8 mm
M 3	5 = 3,2 mm	5 BA = 3,2 mm
	6 = 3,5 mm	4 BA = 3,5 mm
M 4	8 = 4,2 mm	3 BA = 4,2 mm
M 5	10 = 4,8 mm	2 BA = 4,8 mm
M 6	12 = 5,5 mm	1 BA = 5,5 mm
	14 = 6,1 mm	0 BA = 6,1 mm
	1/4" = 6,35 mm	1/4" = 6,35 mm

DIN	USA	British Assoc.
M 8	5/16" = 7,9 mm	5/16" = 7,9 mm
M 10	3/8" = 9,5 mm	3/8" = 9,5 mm
M 12	7/16" = 11,1 mm	7/16" = 11,1 mm
	1/2" = 12,7 mm	1/2" = 12,7 mm
M 16	5/8" = 15,8 mm	5/8" = 15,8 mm
M 20	3/4" = 19,0 mm	3/4" = 19,0 mm
M 26	1" = 25,4 mm	1" = 25,4 mm

Flachsteckhülsen

Flachsteckhülsen für Steckbreite 2,8 mm

Receptacles

Receptacles for tab width 2,8 mm

Bauform Q = Quertransport L = Längstransport Supply condition Q = transverse transport / Side feed L = longitudinal transport / End feed	Artikel-Nummer Part number	DIN	Frei- gaben- s. Seiten 7/8 Appro- vals s. page 7/8	Leiter- quer- schnitt Wire size mm ² AWG	Material	Veredlung			Länge		Steck- dicke Tab thick- ness mm	Rast- posi- tion Inden- tation	Verp.-Einh.	
						blank	Sn	Ni	L 1 mm	L 2 mm			Band	lose
						Finishing								
						un- plated	Sn	Ni				Chain form	loose piece	
												x 1000		

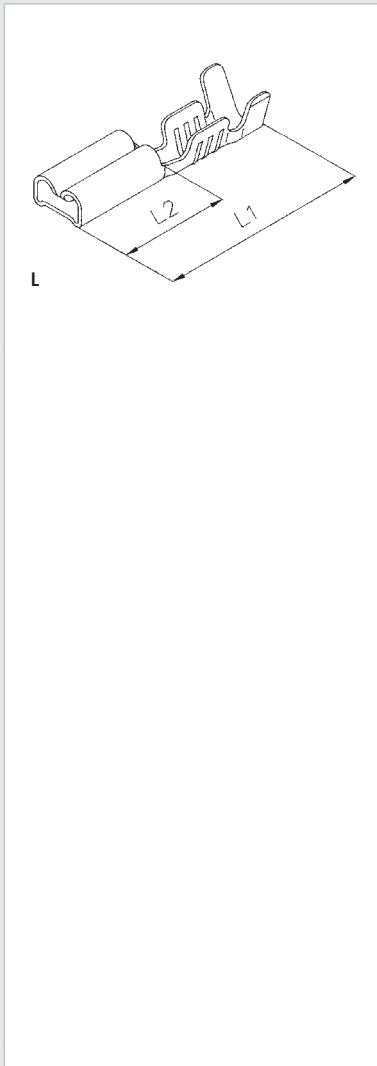

RSB 7605 F 2,8-0,25				0,14-0,34	CuSn	○	○		12,5	5,0	0,8	DIN	25	2
	●			26-22	CuZn	●	●							
					Fe			○						
RSB 7605.001 F 2,8-0,25				0,1-0,25	CuSn	○	○		12,5	5,0	0,5	DIN	25	2
	●			26-22	CuZn	●	●							
					Fe			○						
RSB 7607 F 2,8-0,5				0,25-0,75	CuSn	○	○		12,5	5,0	0,8	DIN	25	2
	●			24-20	CuZn	●	●							
					Fe			○						
RSB 7607.001 F 2,8-0,5				0,25-0,75	CuSn	●	○		12,5	5,0	0,5	DIN	25	2
				24-20	CuZn	○	○							
					Fe			○						
RSB 7606 F 2,8-1		46330 T2		0,5-1	CuSn	●	○		12,5	5,0	0,8	DIN	18	2
		A 2,8-1		20-18	CuZn	●	●							
					Fe			○						
RSB 7606.001 F 2,8-1				0,5-1	CuSn	○	○		12,5	5,0	0,5	DIN	18	2
	●			20-18	CuZn	●	●							
					Fe			○						
RSB 7785.058 F 2,8-0,5	●			0,22-0,5	CuSn	○	○		14,0	6,3	0,8	DIN	18	-
	●			24-20	CuZn	○	○							
	●				Fe			○						
RSB 7785.055 F 2,8-0,5	●			0,22-0,5	CuSn	○	○		14,0	6,3	0,5	DIN	18	-
	●			24-20	CuZn	○	○							
	●				Fe			○						
RSB 7785 F 2,8-1	●			0,5-1	CuSn	○	○		14,0	6,3	0,5	IEC	18	2
	●			20-18	CuZn	●	●							
	●				Fe			●						
RSB 7785.001 F 2,8-1	●			0,5-1	CuSn	○	○		14,0	6,3	0,8	IEC	18	2
	●			20-18	CuZn	●	●							
	●				Fe			●						
RSB 7785.002 F 2,8-1	●	46247 T1		0,5-1	CuSn	○	○		14,0	6,3	0,5	DIN	18	2
	●	A 2,8-1		20-18	CuZn	●	●							
	●				Fe			○						
RSB 7785.003 F 2,8-1	●	46247 T1		0,5-1	CuSn	●	●		14,0	6,3	0,8	DIN	18	2
	●	B 2,8-1		20-18	CuZn	●	●							
	●				Fe			○						

● Standard-Artikel / Standard parts ○ lieferbar auf Anfrage / available on request

Flachsteckhülsen

Flachsteckhülsen für Steckbreite 2,8 mm

Receptacles

Receptacles for tab width 2,8 mm

Bauform Q = Quertransport L = Längstransport	Artikel-Nummer	DIN	Frei- gaben s. Seiten 7/8	Leiter- quer- schnitt	Material	Veredlung			Länge		Steck- dicke	Rast- posi- tion	Verp.-Einh.	
						blank	Sn	Ni	L 1 mm	L 2 mm			Band	lose
						Finishing								
Supply condition Q = transverse transport / Side feed L = longitudinal transport / End feed	Part number		Appro- vals s. page 7/8	Wire size mm ² AWG	Material	un- plated	Sn	Ni			Chain form	loose piece	x 1000	



RSB 7990.058 F 2,8-0,5	0,22-0,5	CuSn			13,8	6,4	0,8	18				
	24-20	CuZn	○	●								
		Fe			○							
RSB 7990.055 F 2,8-0,5	0,22-0,5	CuSn			13,8	6,4	0,5	18				
	24-20	CuZn	○	○								
		Fe			○							
RSB 7990 F 2,8-1	0,5-1	CuSn			13,8	6,4	0,8	18				
	● 20-18	CuZn	●	○								
		Fe			○							
RSB 7990.001 F 2,8-1	0,5-1	CuSn			13,8	6,4	0,5	18				
	● 20-18	CuZn	●	●								
		Fe			○							

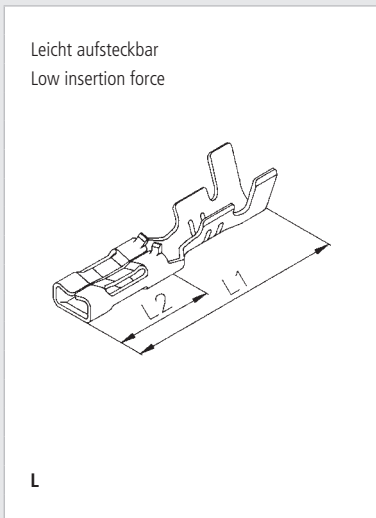

RSB 8100 F 2,8-1	0,5-1	CuSn	○	○	14,0	6,4	0,8	DIN	14			
	20-18	CuZn	●	●								
		Fe			○							
RSB 8100.001 F 2,8-1	0,5-1	CuSn	○	○	14,0	6,4	0,5	DIN	14			
	20-18	CuZn	○	●								
		Fe			○							
RSB 8100.002 F 2,8-1	0,5-1	CuSn	○	○	14,0	6,4	0,5	IEC	14			
	20-18	CuZn	●	●								
		Fe			○							
RSB 8100.003 F 2,8-1	0,5-1	CuSn	○	○	14,0	6,4	0,8	IEC	14			
	20-18	CuZn	●	●								
		Fe			○							
RSB 8100.2055 F 2,8-0,5	0,22-0,5	CuSn	○	○	14,0	6,4	0,5	IEC	14			
	24-20	CuZn	●	○								
		Fe			○							
RSB 8100.2058 F 2,8-0,5	0,22-0,5	CuSn	○	○	14,0	6,4	0,8	IEC	14			
	24-20	CuZn	○	○								
		Fe			●							

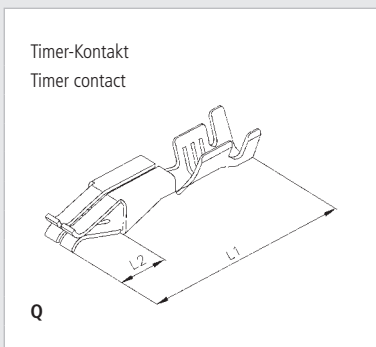

RFB 8113.105 F 2,8-1 Für Gehäusemontage For housings	0,5-1	CuSn	○	○	18,7	5,0	0,5	4,5				
	20-18	CuZn	○	●								
RFB 8113.108 F 2,8-1 Für Gehäusemontage For housings	0,5-1	CuSn	○	○	18,7	5,0	0,8	4,5				
	20-18	CuZn	○	●								
RFB 8113.155 F 2,8-1,5 Für Gehäusemontage For housings	1-2,0	CuSn	○	○	18,7	5,0	0,5	4				
	18-14	CuZn	○	●								

● Standard-Artikel / Standard parts ○ lieferbar auf Anfrage / available on request

Flachsteckhülsen

Flachsteckhülsen für Steckbreite **2,8 mm**

Receptacles

Receptacles for tab width **2,8 mm**

Bauporm Q = Quertransport L = Längstransport Supply condition Q = transverse transport / Side feed L = longitudinal transport / End feed	Artikel-Nummer Part number	DIN	Frei- gaben- s. Seiten 7/8 Appro- vals s. page 7/8	Leiter- quer- schnitt Wire size mm ² AWG	Material	Veredlung			Länge		Steck- dicke Tab thick- ness mm	Rast- posi- tion Inden- tation	Verp.-Einh.	
						blank	Sn	Ni	L 1 mm	L 2 mm			Band	lose
						Finishing								
						un- plated	Sn	Ni			Chain form	loose piece	x 1000	

Für Gehäuse
For housings

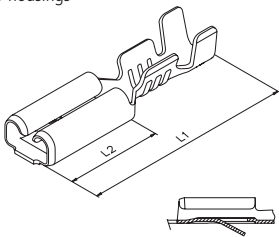

L

RSB 8280.1055 F 2,8-0,5	46340 T1	0,25-0,5	CuSn	●	○	14,0	6,0	0,5	19	
		24-22	CuZn	●	○					
RSB 8280.1058 F 2,8-0,5	46340 T1	0,25-0,5	CuSn	●	○	14,0	6,0	0,8	19	
		24-22	CuZn	●	●					
RSB 8280.1105 F 2,8-1	46340 T1	0,5-1	CuSn	●	○	14,0	6,0	0,5	14	
		20-18	CuZn	●	○					
RSB 8280.1108 F 2,8-1	46340 T1	0,5-1	CuSn	●	○	14,0	6,0	0,8	14	
		20-18	CuZn	●	●					

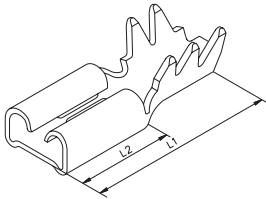

L

RSB 7755.001 F 2,8-0,5 Mit Isolierungsdurchdringung With insulation piercing			0,2	CuZn	○	○	8,2	3,6	0,5	-	25	-
RSB 7755.002 F 2,8-0,5 Mit Isolierungsdurchdringung With insulation piercing			0,2	CuZn	○	●	8,2	3,6	0,8	-	25	-

● Standard-Artikel / Standard parts ○ lieferbar auf Anfrage / available on request

Flachsteckhülsen

Flachsteckhülsen für Steckbreite 4,8 mm

Receptacles

Receptacles for tab width 4,8 mm

Bauform Q = Quertransport L = Längstransport	Artikel-Nummer Part number	DIN	Frei- gaben- s. Seiten 7/8 Appro- vals s. page 7/8	Leiter- quer- schnitt Wire size mm ² AWG	Material	Veredlung			Länge		Steck- dicke Tab thick- ness mm	Rast- posi- tion Inden- tation	Verp.-Einh.	
						blank	Sn	Ni	L 1 mm	L 2 mm			Band	lose
						Finishing								
Supply condition Q = transverse transport / Side feed L = longitudinal transport / End feed					Material	un- plated	Sn	Ni						x 1000

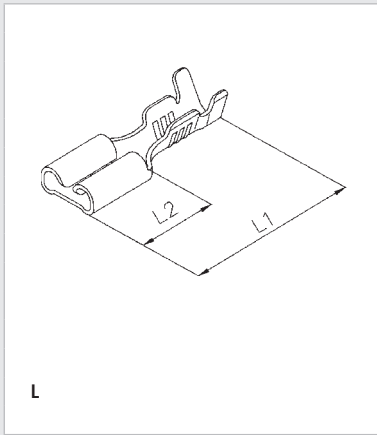

RSB 7603.028 F 4,8-0,2				0,14-0,34	CuSn	○	○		16,0	6,3	0,8	DIN	12	
				24-22	CuZn	○	○							
RSB 7603.108 F 4,8-1	46247 T2 4,8-1			0,5-1	CuSn	○	●		16,0	6,3	0,8	DIN	10	
				20-18	CuZn	●	●							
					Fe			●						
RSB 7603.105 F 4,8-1				0,5-1	CuSn	○	○		16,0	6,3	0,5	DIN	10	
				20-18	CuZn	●	●							
					Fe			●						
RSB 7604.258 F 4,8-2,5	46247 T2 4,8-2,5			>1-2,5	CuSn	○	○		16,0	6,3	0,8	DIN	10	1
				16-14	CuZn	●	●							
					Fe			●						
RSB 7604.255 F 4,8-2,5				>1-2,5	CuSn	○	○		16,0	6,3	0,5	DIN	10	1
				16-14	CuZn	○	○							
					Fe			○						

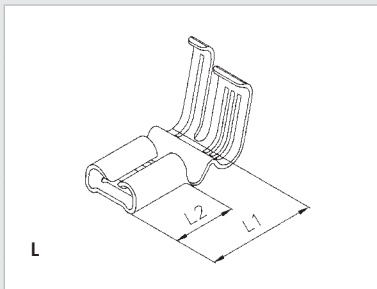

RSB 7936.002 F 4,8-1,5				0,5-1,5	CuSn	○	○		10,0	6,0	0,8	DIN	3	
				20-16	CuZn	○	●							
					Fe			○						
RSB 7936.003 F 4,8-1,5				0,5-1,5	CuSn	○	○		10,0	6,0	0,5	DIN	3	
				20-16	CuZn	●	●							
					Fe			○						

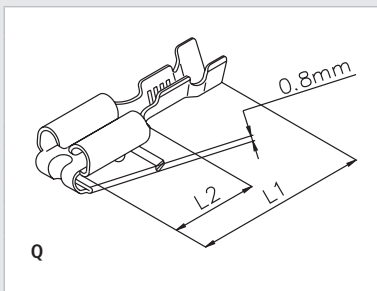

RSB 7984 X 4,8-1,5				0,5-1,5	CuSn				16,0	6,0	0,8	DIN	2,5	
				20-16	CuZn	●	●							
					Fe			●						
RSB 7984.001 X 4,8-1,5				0,5-1,5	CuSn				16,0	6,0	0,5	DIN	2,5	
				20-16	CuZn	○	○							
					Fe			○						

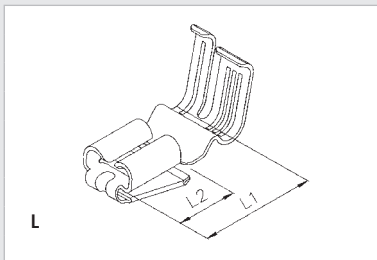

RSB 8064 X 4,8-1,5				0,5-1,5	CuSn				11,5	6,0	0,8	DIN	2,5	
				20-16	CuZn	○	○							
					Fe									

● Standard-Artikel / Standard parts ○ lieferbar auf Anfrage / available on request

Flachsteckhülsen

Flachsteckhülsen für Steckbreite 4,8 mm

Receptacles

Receptacles for tab width 4,8 mm

Bauform Q = Quertransport L = Längstransport Supply condition Q = transverse transport / Side feed L = longitudinal transport / End feed	Artikel-Nummer Part number	DIN	Freigabens. Seiten 7/8 Approvals s. page 7/8	Leiterquerschnitt Wire size mm ² AWG	Material	Veredlung			Länge		Steckdicke Tab thickness mm	Rastposition Indentation	Verp.-Einh.	
						blank	Sn	Ni	L 1 mm	L 2 mm			Band	lose
						Finishing								
						un-plated	Sn	Ni					x 1000	

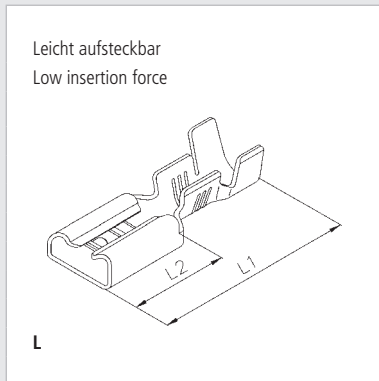

RSB 8170.058 F 4,8-0,5				0,22-0,75 24-20	CuSn	○	○		14,5	6,2	0,8	DIN	18	
					CuZn	●	●							
						Fe			●					
RSB 8170.055 F 4,8-0,5				0,22-0,75 24-20	CuSn	○	○		14,5	6,2	0,5	DIN	18	
					CuZn	●	●							
					Fe			●						
RSB 8170.158 F 4,8-1,5				>0,75-2,0 18-14	CuSn	○	○		14,5	6,2	0,8	DIN	14	
	●				CuZn	●	●							
	●				Fe			●						
RSB 8170.155 F 4,8-1,5				>0,75-2,0 18-14	CuSn	○	○		14,5	6,2	0,5	DIN	14	
	●				CuZn	●	●							
	●				Fe			●						

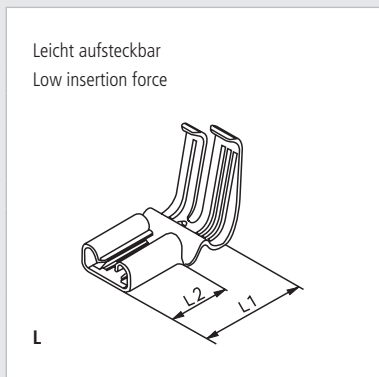

RSB 8186.158 F 4,8-1,5				0,5-1,5 20-16	CuSn	○	○		10,0	6,0	0,8	DIN	3	
					CuZn	●	●							
					Fe			●						
RSB 8186.155 F 4,8-1,5				0,5-1,5 20-16	CuSn	○	○		10,0	6,0	0,5	DIN	3	
					CuZn	●	●							
					Fe			●						

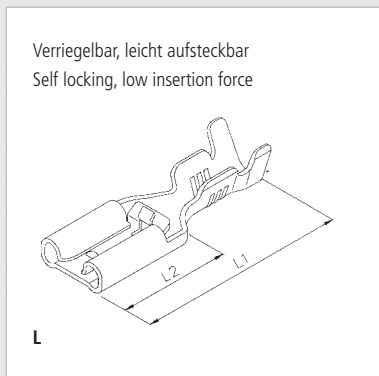

RSB 8168.058 F 4,8-0,5	●			0,22-0,75 24-20	CuSn	○	○		16,3	6,3	0,8	DIN	10	
					CuZn	●	●							
					CuNiZn	○								
RSB 8168.055 F 4,8-0,5	●			0,22-0,75 24-20	CuSn	○	○		16,3	6,3	0,5	DIN	10	
					CuZn	●	●							
					CuNiZn	○								
RSB 8168.158 F 4,8-1,5	●			>0,75-2,0 18-14	CuSn	○	○		16,3	6,3	0,8	DIN	10	
					CuZn	●	●							
					CuNiZn	○								
RSB 8168.155 F 4,8-1,5	●			>0,75-2,0 18-14	CuSn	○	○		16,3	6,3	0,5	DIN	10	
					CuZn	●	●							
					CuNiZn	○								

● Standard-Artikel / Standard parts ○ lieferbar auf Anfrage / available on request

Flachsteckhülsen

Flachsteckhülsen für Steckbreite **4,8 mm**

Receptacles

Receptacles for tab width **4,8 mm**

Bauform Q = Quertransport L = Längstransport	Artikel-Nummer	DIN	Freigabenseiten 7/8	Leiterquerschnitt Wire size mm ² AWG	Material	Veredlung			Länge		Steckdicke	Rastposition	Verp.-Ein.	
						blank	Sn	Ni	L 1	L 2			Band	lose
Supply condition Q = transverse transport / Side feed L = longitudinal transport / End feed	Part number		Approvals s. page 7/8		Material	Finishing			Length		Tab thickness	Indentation	Packing unit	
						un-plated	Sn	Ni	mm	mm	mm		Chain form	loose piece
														x 1000

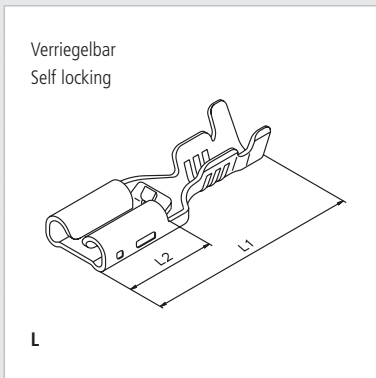

RSB 8028 F 4,8-1		0,5-1		CuSn	○	●		17,0	6,3	0,8	DIN	9		
	●	20-18		CuZn	●	●	●							
				CuNiZn	○									
RSB 8028.001 F 4,8-1		0,5-1		CuSn	○	○		17,0	6,3	0,5	DIN	9		
	●	20-18		CuZn	●	●								
				CuNiZn	○									
RSB 8029 F 4,8-2,5		1,5-2,5		CuSn	○	○		17,0	6,3	0,8	DIN	9		
	●	16-14		CuZn	●	●								
				CuNiZn	○									
RSB 8029.001 F 4,8-2,5		1,5-2,5		CuSn	○	○		17,0	6,3	0,5	DIN	9		
	●	16-14		CuZn	○	●								
				CuNiZn	○									

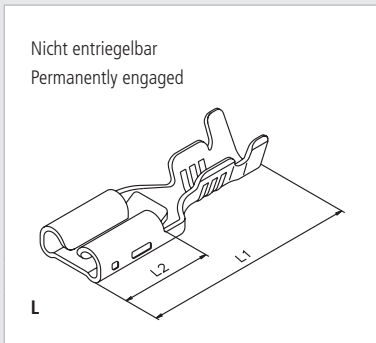

RSB 8028.002 F 4,8-1		0,5-1		CuSn	○	○		17,0	6,3	0,8	DIN	9		
		20-18		CuZn	○	●								
				CuNiZn	○									
RSB 8028.003 F 4,8-1		0,5-1		CuSn	○	○		17,0	6,3	0,5	DIN	9		
		20-18		CuZn	○	○								
				CuNiZn	○									
RSB 8029.2258		1,5-2,5		CuZn		●	○	17,0	6,3	0,8	DIN	9		
		16-14												

● Standard-Artikel / Standard parts ○ lieferbar auf Anfrage / available on request

Flachsteckhülsen

Flachsteckhülsen für Steckbreite 6,3 mm

Receptacles

Receptacles for tab width 6,3 mm

Bauform Q = Quertransport L = Längstransport	Artikel-Nummer	DIN	Frei- gaben s. Seiten 7/8	Leiter- quer- schnitt	Material	Veredlung			Länge		Steck- dicke	Rast- posi- tion	Verp.-Einh.	
						blank	Sn	Ni	L 1	L 2			Band	lose
Supply condition Q = transverse transport / Side feed L = longitudinal transport / End feed	Part number		Appro- vals s. page 7/8	Wire size	Material	Finishing			Length		Tab thick- ness	Inden- tation	Packing unit	
				mm ² AWG		un- plated	Sn	Ni	mm	mm	mm		Chain form	loose piece
														x 1000

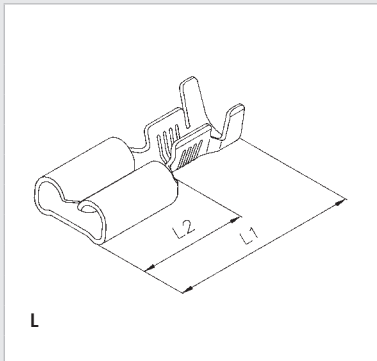

RSB 8115 F 6,3-0,2				0,12-0,35	CuSn	○	○		19,0	7,7	0,8	DIN	8	
				26-22	CuZn	○	○							
RSB 7900 F 6,3-1	46247 T3 6,3-1	●		0,5-1,5	CuSn	●	●		19,0	7,7	0,8	DIN	8	1
				20-16	CuZn	●	●							
					Fe			●						
RSB 7901 F 6,3-2,5	46247 T3 6,3-2,5	●		>1-2,5	CuSn	●	●		19,0	7,7	0,8	DIN	6	1
				16-14	CuZn	●	●							
					Fe			●						
RSB 8152 F 6,3-6	46247 T3 6,3-6	●		2,5-6	CuSn	○	●		19,0	7,7	0,8	DIN	5	1
				14-10	CuZn	●	●							
					Fe			●						

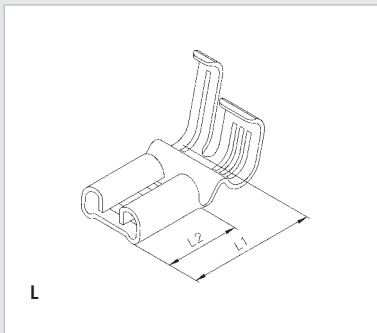

RSB 7944.010 F 6,3-1,5		●		0,5-1,5	CuSn	○	○		11,5	7,7	0,8	DIN	2	
				20-16	CuZn	●	●							
					Fe			●						
					CuNiSi	○	○							
RSB 7944.258 F 6,3-2,5		●		1,5-2,5	CuSn	○	○		11,5	7,7	0,8	DIN	1,8	
				16-14	CuZn	●	●							
					Fe			●						

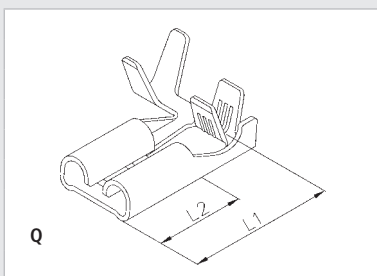

RSB 8138 F 6,3-2,5	46346	●		1-2,5	CuSn	○	○		14,2	7,7	0,8	DIN	3,5	1
				16-14	CuZn	●	●							
					Fe			●						
RSB 8138.108	46346	●		0,5-1	CuSn				14,2	7,7	0,8	DIN	8	1
				20-18	CuZn	●	●							
					Fe			●						

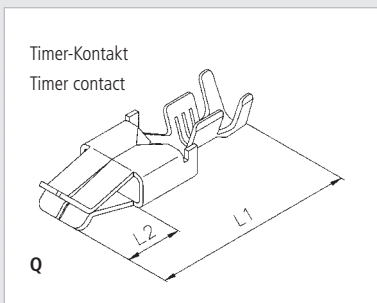

RFB 7979 F 6,3-1	Für Gehäusemontage For housings	●		0,5-1,5	CuSn	○	○		19,5	6,0	0,8		3	
				20-16	CuZn	●	●							
					Fe									
RFB 7979.001 F 6,3-2,5	Für Gehäusemontage For housings	●		>1-2,5	CuSn	○	○		19,5	6,0	0,8		2,5	
				16-14	CuZn	○	○							
					Fe									
RFB 7979.002 F 6,3-4	Für Gehäusemontage For housings			2,5-4	CuSn	○	○		19,5	6,0	0,8		2,5	
				14-12	CuZn	○	○							
					Fe									

● Standard-Artikel / Standard parts ○ lieferbar auf Anfrage / available on request

Flachsteckhülsen

Flachsteckhülsen für Steckbreite **6,3 mm**

Receptacles

Receptacles for tab width **6,3 mm**

Bauform Q = Quertransport L = Längstransport	Artikel-Nummer	DIN	Freigabens. Seiten 7/8	Leiterquerschnitt Wire size mm ² AWG	Material	Veredlung			Länge		Steckdicke	Rastposition	Verp.-Einh.		Winkel
						blank	Sn	Ni	L 1	L 2			Band	lose	
Supply condition Q = transverse transport / Side feed L = longitudinal transport / End feed	Part number		Approvals s. page 7/8		Material	Finishing			Length		Tab thickness	Indentation	Packing unit		Angle
						un-plated	Sn	Ni	L 1	L 2			Chain form	loose piece	
									mm	mm	mm			x 1000	

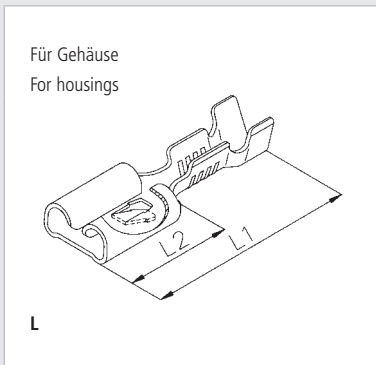

RSB 7916 F 6,3-1	46340 T3			0,5-1,5	CuSn	○	○		19,3	7,7	0,8		6	1	
	A 6,3-1			20-16	CuZn	●	●								
RSB 7916.001 F 6,3-1	46340 T3			0,5-1,5	CuSn	●	○		19,3	7,7	0,8	DIN	6	1	
	B 6,3-1			20-16	CuZn	●	●								
RSB 7858 F 6,3-2,5	46340 T3			1-<2,5	CuSn	○	○		19,3	7,7	0,8		6	1	
	A 6,3-2,5		●	18-14	CuZn	●	●								
RSB 7858.001 F 6,3-2,5	46340 T3			1-<2,5	CuSn	●	●		19,3	7,7	0,8	DIN	6	1	
	B 6,3-2,5		●	18-14	CuZn	●	●								
					Fe										

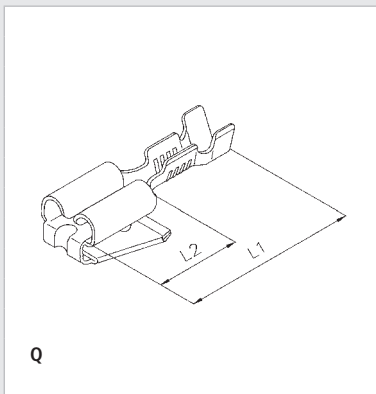

RSB 7630 X 6,3-1,5			●	0,5-1,5	CuSn	●	●		19,8	7,7	0,8	DIN	1,4	0,5	10°
			●	20-16	CuZn	●	●								
			●		Fe			●							
RSB 7630.001 X 6,3-1,5			●	0,5-1,5	CuSn	●	○		19,8	7,7	0,8	DIN	0,9	0,5	30°
			●	20-16	CuZn	●	○								
			●		Fe			●							
RSB 7631 X 6,3-2,5			●	1-2,5	CuSn	○	●		19,8	7,7	0,8	DIN	1,3	0,5	10°
			●	16-14	CuZn	●	●								
			●		Fe			●							
RSB 7631.001 X 6,3-2,5			●	1-2,5	CuSn	○	●		19,8	7,7	0,8	DIN	0,8	0,5	30°
			●	16-14	CuZn	○	○								
			●		Fe			●							

● Standard-Artikel / Standard parts ○ lieferbar auf Anfrage / available on request

Flachsteckhülsen

Flachsteckhülsen für Steckbreite 6,3 mm

Receptacles

Receptacles for tab width 6,3 mm

Bauform Q = Quertransport L = Längstransport Supply condition Q = transverse transport / Side feed L = longitudinal transport / End feed	Artikel-Nummer	DIN	Frei- gaben- s. Seiten 7/8	Leiter- quer- schnitt	Material	Veredlung			Länge		Steck- dicke	Rast- posi- tion	Verp.-Einh.		
	Part number		Appro- vals s. page 7/8	Wire size	Material	un- plated	Sn	Ni	Length		Tab thick- ness	Inden- tation	Packing unit		
				mm ² AWG					L 1 mm	L 2 mm	mm		Chain form	loose piece	x 1000

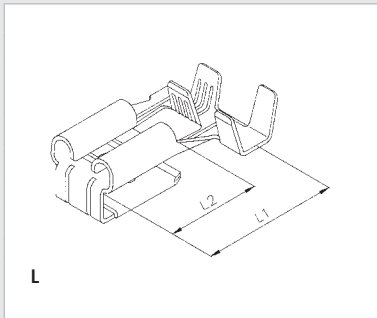

RSB 8068 F 6,3-2,5	>1-2,5	CuSn	○	○	14,8	7,6	0,8	DIN	1,5	
	16-14	CuZn	○	●						
		Fe								

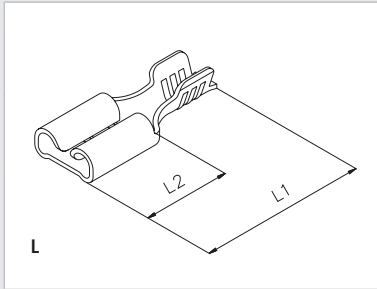

RSB 7601.030 F 6,3-2,5	>1-2,5	CuZn	●	●	15,0	7,7	0,8	DIN	6	
Ohne Isocrimp Without insulation support	16-14									

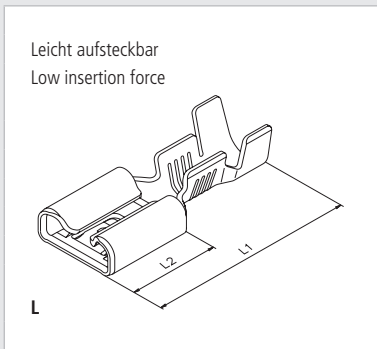

RSB 8260.155 F 6,3-1,5	0,5-1,5	CuSn			17,15	7,7	0,5	DIN	8	
	20-16	CuZn	●	○						
		Fe		○						
RSB 8260.158 F 6,3-1,5	● 0,5-1,5	CuSn	○	○	17,15	7,7	0,8	DIN	8	
	● 20-16	CuZn	●	●						
	●	Fe		○						
RSB 8260.258 F 6,3-2,5	● >1-2,5	CuSn	○	○	17,15	7,7	0,8	DIN	6	
	● 16-14	CuZn	●	●						
	●	Fe		●						

● Standard-Artikel / Standard parts ○ lieferbar auf Anfrage / available on request

Flachsteckhülsen

Flachsteckhülsen für Steckbreite 6,3 mm

Receptacles

Receptacles for tab width 6,3 mm

Bauform Q = Quertransport L = Längstransport	Artikel-Nummer	DIN	Freigabens. Seiten 7/8	Leiterquerschnitt Wire size mm ² AWG	Material	Veredlung			Länge		Steckdicke	Rastposition	Verp.-Einh.		
						blank	Sn	Ni	L 1 mm	L 2 mm			Chain form	loose piece	
Supply condition Q = transverse transport / Side feed L = longitudinal transport / End feed	Part number		Approvals s. page 7/8		Material	Finishing					Length				Tab thickness
						un-plated	Sn	Ni			mm				

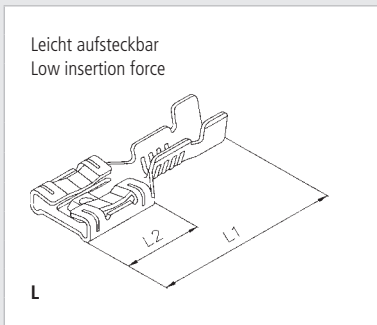

RSB 8137 F 6,3-0,5		0,2-0,5	CuSn	○	○		19,0	7,6	0,8	DIN	8		
		24-20	CuZn	○	○	○							
			Fe			○							
RSB 8136 F 6,3-4		2,5-4	CuSn	○	○		19,0	7,6	0,8	DIN	4,5		
		14-10	CuZn	○	○	○							
		*	Fe			●							
* Doppelcrimp Double crimp	2 x 1,5 mm ² 2 x 2,5 mm ² 2 x AWG 14-16												

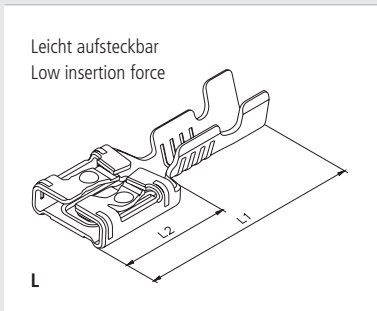

RSB 8238.158		0,5-<1,5	CuSn				19,0	7,4	0,8	DIN	8		
		● 20-16	CuZn	●	●								
		●	Fe			●							
RSB 8238.258		1,5-2,5	CuSn				19,0	7,4	0,8	DIN	8		
		● 16-14	CuZn	●	●								
		●	Fe			●							

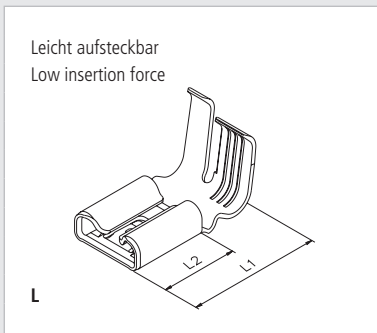

RSB 8240.158 F 6,3-1,5		0,5-1,5	CuSn	○	○		11,5	7,7	0,8	DIN	2		
		● 20-16	CuZn	●	●								
		●	Fe			●							
RSB 8240.258 F 6,3-2,5		1,5-2,5	CuSn	○	○		11,5	7,7	0,8	DIN	1,8		
		● 16-14	CuZn	●	●								
		●	Fe			●							
RSB 8240.1158 F 6,3-1,5 Für Gehäusemontage For housings		0,5-1,5	CuSn	○	○		11,5	7,7	0,8		2		
		● 20-16	CuZn	●	●								
		●	Fe			●							

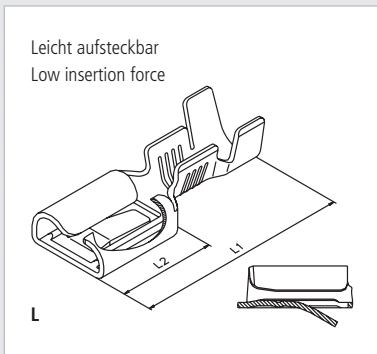

RSB 8180.1158 F 6,3-1,5 Für Gehäusemontage For housings		0,5-1,5	CuSn				17,15	7,7	0,8		8		
		● 20-16	CuZn										
		●	Fe			●							

● Standard-Artikel / Standard parts ○ lieferbar auf Anfrage / available on request

Flachsteckhülsen

Flachsteckhülsen für Steckbreite 6,3 mm

Receptacles

Receptacles for tab width 6,3 mm

Bauform Q = Quertransport L = Längstransport	Artikel-Nummer	DIN	Freigabens. Seiten 7/8	Leiterquerschnitt	Material	Veredlung			Länge		Steckdicke	Rastposition	Verp.-Einh.	
						blank	Sn	Ni	L 1 mm	L 2 mm			Band	lose
						Finishing								
Supply condition Q = transverse transport / Side feed L = longitudinal transport / End feed	Part number		Approvals s. page 7/8	Wire size mm ² AWG	Material	un-plated	Sn	Ni	Length	Tab thickness mm	Indentation	Chain form	loose piece	
													x 1000	

Verriegelbar, leicht aufsteckbar
Self locking, low insertion force

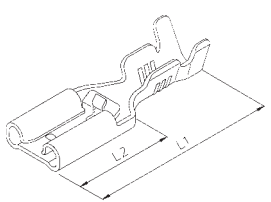

L

RSB 8178.108 F 6,3-1 Geeignet für RAST 5 Gehäuse Also for RAST 5 housings	●	0,5-<1	CuSn	○	○	19,2	7,7	0,8	DIN	8		
	●	22-18	CuZn	●	●							
			CuNiZn	○								
RSB 8178.258 F 6,3-2,5 Geeignet für RAST 5 Gehäuse Also for RAST 5 housings	●	1-<2,5	CuSn	○	○	19,2	7,7	0,8	DIN	6,5		
	●	16-14	CuZn	●	●							
			CuNiZn	○								
RSB 8178.308 F 6,3-3* Geeignet für RAST 5 Gehäuse Also for RAST 5 housings	●	2 x AWG	CuSn	○	○	19,2	7,7	0,8	DIN	4		
	●	18-16	CuZn	●	●							
			CuNiZn	○								
RSB 7960.020 F 6,3-1 verriegelbar self locking	●	0,5-1	CuSn	○	○	19,3	7,7	0,8	DIN	7	1	
	●	20-18	CuZn	○	○							
	●		CuNiZn	○								
RSB 7961.020 F 6,3-2,5 verriegelbar self locking	●	1-2,5	CuSn	○	○	19,3	7,7	0,8	DIN	6	1	
	●	16-14	CuZn	○	○							
			CuNiZn	○								

Verriegelbar
Self locking

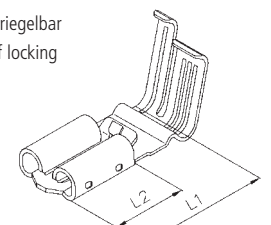

L

RSB 8126.010 F 6,3-1,5	●	0,5-1,5	CuSn	○	○	16,0	7,1	0,8	DIN	1,6		
	●	20-16	CuZn	○	○							

Verriegelbar
Self locking

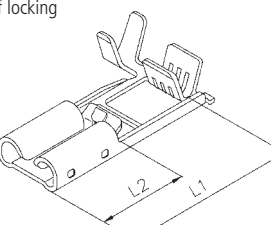

Q

RSB 8047 F 6,3-1		0,5-1	CuSn	○	○	18,5	7,7	0,8	DIN	4		
	●	20-18	CuZn	○	○							
			CuNiZn	○								
RSB 8048 F 6,3-2,5		>1-2,5	CuSn	○	○	18,5	7,7	0,8	DIN	3,5		
		16-14	CuZn	○	○							
			CuNiZn	○								

* Technisches Datenblatt über verarbeitbare Isolationsdurchmesser auf Anfrage.
Technical datasheet for available insulation diameters on request.

● Standard-Artikel / Standard parts ○ lieferbar auf Anfrage / available on request

Flachstecker

Flachstecker mit Steckbreite **2,8 mm**

Tabs

Tabs width **2,8 mm**

Bauform Q = Quertransport L = Längstransport Supply condition Q = transverse transport / Side feed L = longitudinal transport / End feed	Artikel-Nummer Part number	DIN	Freigabens. Seiten 7/8 Approvals s. page 7/8 AWG	Leiterquerschnitt Wire size mm ² AWG	Material	Veredlung			Länge		Steckbreite Tab thickness mm	Steckdicke Tab thickness mm	Rastposition Indentation	Verp.-Einh.	
						blank	Sn	Ni	L 1 mm	L 2 mm				Band	lose
						Finishing									
						un-plated	Sn	Ni							x 1000

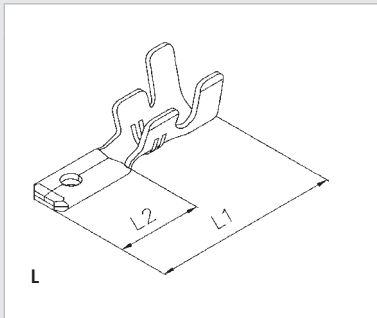

RMB 7958 F 2,8-1			0,5-1 20-18	CuSn CuZn	●	●		12,6	5,5	2,8	0,8	●	15	

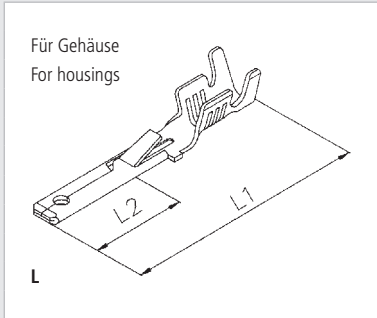

RMB 8039.001 Z 2,8-1			0,5-1,5 20-16	CuSn CuZn	○	○		22,5	8,0	2,8	0,8	DIN	8	
					●	●								
RMB 8039.003 Z 2,8-1			0,5-1,5 20-16	CuSn CuZn	○	○		22,5	8,0	2,8	0,8	ohne wit- hout	8	
					●	●								

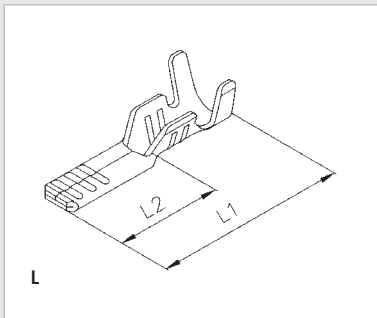

RMB 7930 V 2,8-1			0,5-1 20-18	CuSn CuZn	●	○		13,1	6,7	2,8	0,8	ohne wit- hout	18	2

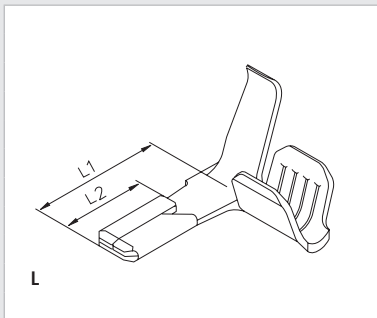

RMB 8205.1158 Z 2,8-1,5			0,75-2 18-14	CuZn	●			8,0	4,75	2,8	0,8	ohne wit- hout	6	

● Standard-Artikel / Standard parts ○ lieferbar auf Anfrage / available on request

Flachstecker

Flachstecker mit Steckbreite **4,8 mm**

Tabs

Tabs width **4,8 mm**

Bauform Q = Quertransport L = Längstransport Supply condition Q = transverse transport / Side feed L = longitudinal transport / End feed	Artikel-Nummer Part number	DIN	Freigabens. Seiten 7/8 Approvals s. page 7/8 AWG	Leiterquerschnitt Wire size mm ² AWG	Material	Veredlung			Länge		Steckbreite Tab thickness mm	Steckdicke Tab thickness mm	Rastposition Indentation	Verp.-Einh.	
						blank	Sn	Ni	L 1 mm	L 2 mm				Band	lose
						Finishing									
						un-plated	Sn	Ni					Chain form	loose piece	
														x 1000	

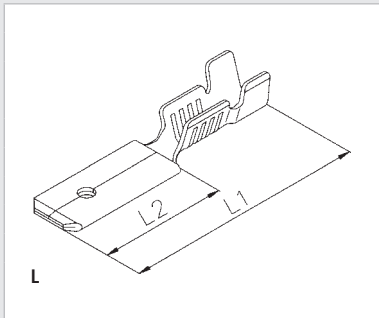

RMB 8165.108 Z 4,8-1			●	0,5-1,5 20-16	CuZn	●	●		21,7	11,4	4,8	0,8	●	8	
-----------------------------	--	--	---	------------------	------	---	---	--	------	------	-----	-----	---	---	--

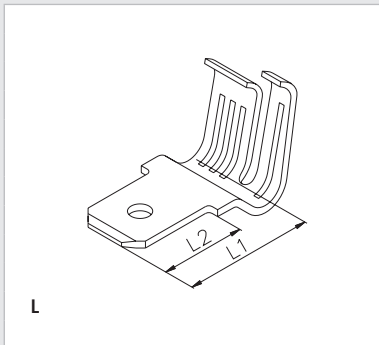

RMB 8043 Z 4,8-1				0,5-1 20-18	CuZn Fe	●			10,2	6,3	4,8	0,5	●	4	
-------------------------	--	--	--	----------------	------------	---	--	--	------	-----	-----	-----	---	---	--

● Standard-Artikel / Standard parts ○ lieferbar auf Anfrage / available on request

Flachstecker

Flachstecker mit Steckbreite **6,3 mm**

Tabs

Tab width **6,3 mm**

Bauform Q = Quertransport L = Längstransport	Artikel-Nummer	DIN	Frei- gaben- s. Seiten 7/8	Leiter- quer- schnitt	Material	Veredlung			Länge		Steck- breite	Steck- dicke	Rast- posi- tion	Verp.-Einh.	
						blank	Sn	Ni	L 1 mm	L 2 mm				Band	lose
						un- plated	Sn	Ni							
Supply condition Q = transverse transport / Side feed L = longitudinal transport / End feed	Part number		Appro- vals s. page 7/8	Wire size mm ²	Material	Finishing			Length		Tab thick- ness	Tab thick- ness	Inden- tation	Packing unit	
				AWG		un- plated	Sn	Ni	L 1 mm	L 2 mm	mm	mm		Chain form	loose piece

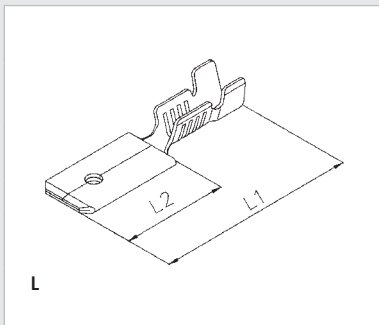

RMB 7840 Z 6,3-1				0,5-1,5	CuSn				21,7	11,4	6,3	0,8	DIN	8	1
				20-16	CuZn	●	●								
RMB 7841 Z 6,3-2,5				>1-2,5	CuSn				21,7	11,4	6,3	0,8	DIN	6	1
				16-14	CuZn	●	●								

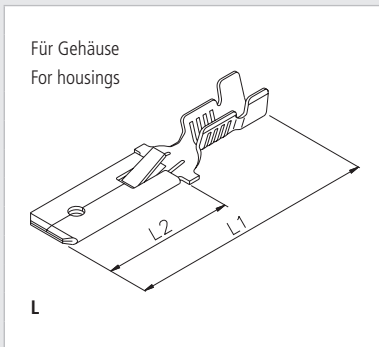

RMB 7831.010 Z 6,3-1	46343 T 3			0,5-1,5	CuSn	●	●		28,0	15,5	6,3	0,8	DIN	5,5	1
	B 6,3-1		●	20-16	CuZn	●	●								
RMB 7831.011 Z 6,3-1	46343 T 3			0,5-1,5	CuSn	●	○		28,0	15,5	6,3	0,8	ohne with- out	5,5	1
	A 6,3-1		●	20-16	CuZn	●	●								
RMB 7833.010 Z 6,3-2,5	46343 T 3			1-2,5	CuSn	●	●		28,0	15,5	6,3	0,8	DIN	4,5	1
	B 6,3-2,5		●	16-14	CuZn	●	●								
RMB 7833.011 Z 6,3-2,5	46343 T 3			1-2,5	CuSn	●	●		28,0	15,5	6,3	0,8	ohne with- out	4,5	1
	A 6,3-2,5		●	16-14	CuZn	●	●								

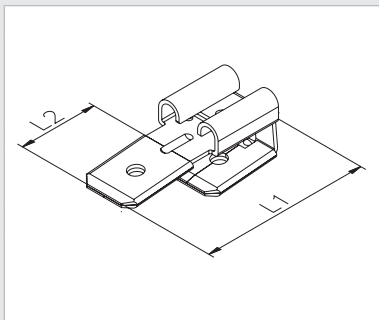

RM 5889 x 6,3					CuSn				18,3	8,0	6,3	0,8	●		1
					CuZn	○									

● Standard-Artikel / Standard parts ○ lieferbar auf Anfrage / available on request

Leiterplatten-Kontakte

Crimpkontakte für Leiterplatten

Printed boards contacts

Crimp contacts for printed boards

Bauform Q = Quertransport L = Längstransport	Artikel-Nummer Part number	Leiter- quer- schnitt Wire size mm ² AWG	Material	Veredlung			Abmessungen			Material- stärke Material thickness mm	Verp.-Einh. Band Packing unit Chain form x 1000
				blank	Sn	Ni	Dimensions				
				un- plated	Sn	Ni	B 1 mm	L 1 mm	L 2 mm		
Supply condition Q = transverse transport / Side feed L = longitudinal transport / End feed											

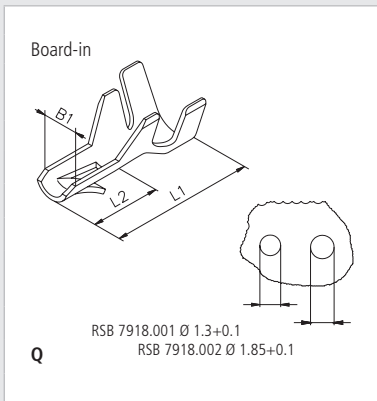

RSB 7918.001 V 1,2-0,35	0,12-0,35 26-22	CuZn		●		1,22	6,6	2,75	0,2	12
RSB 7918.002 V 1,6-0,8	0,32-1 22-18	CuZn		●		1,63	6,6	2,75	0,2	8

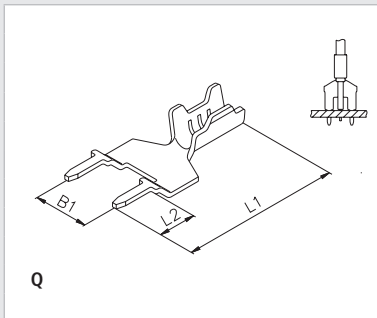

RVB 8055 P 0,8	coax. ISO Ø 1,7	CuZn		○		5,08	15,2	3,5	0,4	8,5
-----------------------	-----------------------	------	--	---	--	------	------	-----	-----	-----

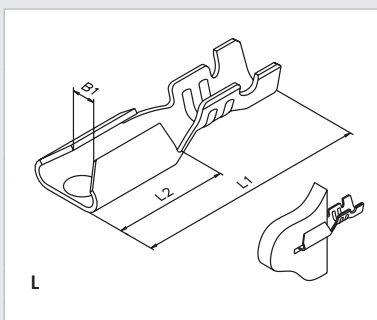

RVB 8014 V 3,4-0,5	0,25-0,5 22-20	CuSn				1,5	12,3	5,0	0,25	20
Direkt-Platinenmontage Direct board edge		CuZn		●						

● Standard-Artikel / Standard parts ○ lieferbar auf Anfrage / available on request

Leiterplatten-Kontakte

Crimpkontakte für Leiterplatten

Printed boards contacts

Crimp contacts for printed boards

Bauform Q = Quertransport L = Längstransport	Artikel-Nummer	Leiter- quer- schnitt	Material	Veredlung			Steck- breite	Länge		Steck- dicke	Material stärke	Verp.-Einh.	
				blank	Sn	Ni		Tab width	Length			Chain form	loose piece
				Finishing									
				un- plated	Sn	Ni							
Supply condition Q = transverse transport / Side feed L = longitudinal transport / End feed	Part number	Wire size	Material	un- plated	Sn	Ni	mm	L 1 mm	L 2 mm	mm	Material thickness	Chain form	loose piece
		mm ² AWG					mm	mm	mm	mm			x 1000

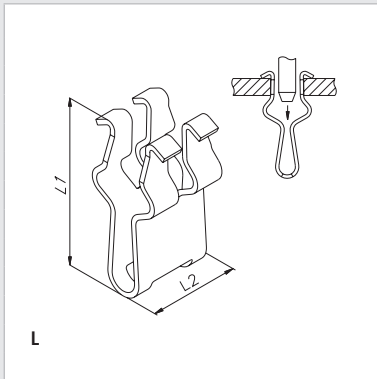

Artikel-Nummer	Leiter- quer- schnitt	Material	Veredlung	Steck- breite	L 1 mm	L 2 mm	Steck- dicke	Material stärke	Verp.-Einh.
RVB 8053		CuSn	○	4,8/6,3	10,2	5	0,8	0,32	10

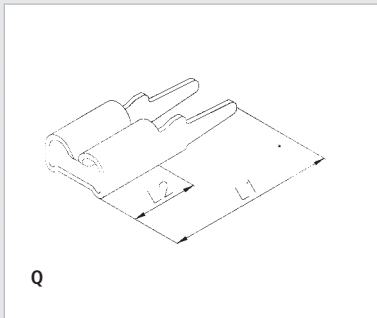

Artikel-Nummer	Leiter- quer- schnitt	Material	Veredlung	Steck- breite	L 1 mm	L 2 mm	Steck- dicke	Material stärke	Verp.-Einh.
RSB 8083 F 2,8-0		CuZn	○	2,8	12,0	6	0,8	0,25	8 0,5

● Standard-Artikel / Standard parts ○ lieferbar auf Anfrage / available on request

Leiterplatten-Kontakte

Flachstecker für Leiterplatten, Steckbreite **2,8 mm**

Printed boards contacts

Tabs for printed circuits, width **2,8 mm**

Bauform Q = Quertransport L = Längstransport Supply condition Q = transverse transport / Side feed L = longitudinal transport / End feed	Artikel-Nummer Part number	Material	Veredlung			Länge			Steck- dicke Tab thick- ness mm	Steck- breite Tab width mm	Rast- loch Inden- tation	Verp.-Einh.	
			blank	Sn	Ni	L 1 mm	L 2 mm	L 3 mm				Band	lose
			Finishing										
			un- plated	Sn	Ni	Packing unit							
											Chain form	loose piece	
											x 1000		

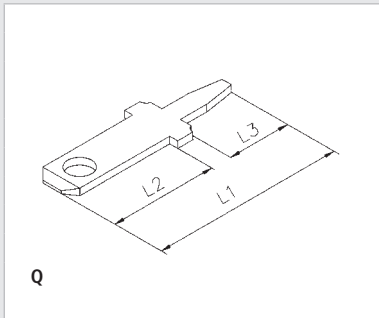

RMB 5920.003 P 1,4-2,8	CuSn				13,2	7,5	4,1	0,5	2,8	●	20	2
	CuZn	○	●									
	Fe											
RMB 5920.004 P 1,4-2,8	CuSn				13,2	7,5	4,1	0,8	2,8	●	20	2
	CuZn	●	●									
	Fe											

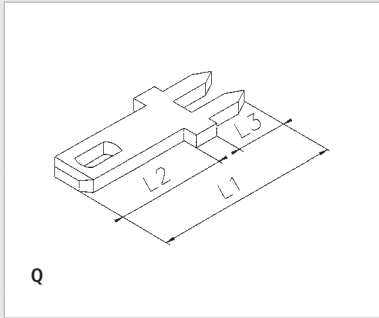

RMB 6198	CuSn				11,7	min. 7	3	0,5	2,8	●	30	
	CuZn	○	●									
	Fe											
RMB 6198.001	CuSn				11,7	min. 7	3	0,8	2,8	●	20	
	CuZn	○	●									
	Fe											

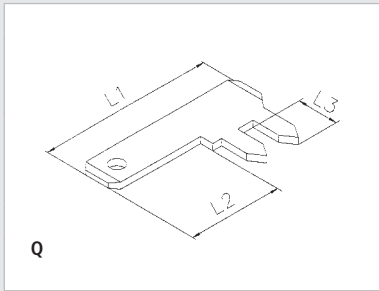

RMB 6199	CuSn				12,5	min. 7	3	0,5	2,8	●	12	
	CuZn	○	●									
	Fe											

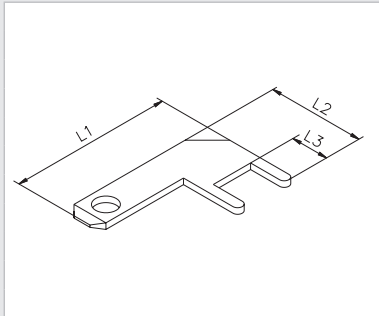

RM 6044 P 1,2 - 2,8	CuSn				13,5	7,0	3	0,8	2,8		DIN	10
	CuZn		○									
	Fe											
RM 6044.001 P 1,2 - 2,8	CuSn				13,5	7,0	3	0,5	2,8		DIN	10
	CuSn	○	○									
	Fe											

● Standard-Artikel / Standard parts ○ lieferbar auf Anfrage / available on request

Leiterplatten-Kontakte

Flachstecker für Leiterplatten, Steckbreite **4,8 mm**

Printed boards contacts

Tabs for printed circuits, width **4,8 mm**

Bauform Q = Quertransport L = Längstransport	Artikel-Nummer	Material	Veredlung			Länge			Steck- dicke	Steck- breite	Rast- loch	Verp.-Einh.		
			blank	Sn	Ni	L 1 mm	L 2 mm	L 3 mm				Inden- tation	Packing unit	
			Finishing										Chain form	loose piece
			un- plated	Sn	Ni									
Supply condition Q = transverse transport / Side feed L = longitudinal transport / End feed	Part number	Material											x 1000	

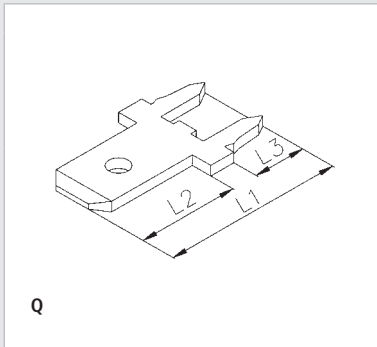

RMB 6008 P 1,3-4,8	CuSn				14,0	8,0	4,0	0,8	4,8	●	15	2
	CuZn	○	●									
RMB 6008.001 P 1,3-4,8	CuSn				14,0	8,0	4,0	0,5	4,8	●	15	2
	CuZn	○	○									
RMB 6008.002 P 1,3-4,8	CuSn	○	○		14,0	8,0	4,0	0,8	4,8	DIN	15	2
	CuZn	○	○									
RMB 6008.003 P 1,3-4,8	CuSn				14,0	8,0	4,0	0,5	4,8	●	15	2
	CuZn	○	○									

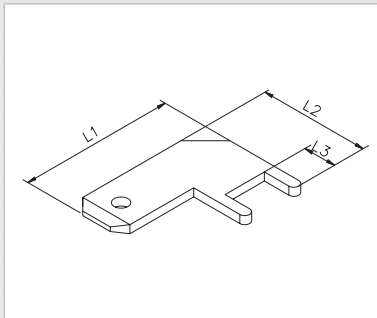

RM 6045 P 1,2-4,8	CuSn				13,5	7,0	3,0	0,8	4,8	●		2
	CuZn		○									

● Standard-Artikel / Standard parts ○ lieferbar auf Anfrage / available on request

Leiterplatten-Kontakte

Flachstecker für Leiterplatten, Steckbreite **6,3 mm**

Printed boards contacts

Tabs for printed circuits, width **6,3 mm**

Bauform Q = Quertransport L = Längstransport	Artikel-Nummer	Material	Veredlung			Abmessungen			Steck- dicke	Steck- breite	Rast- loch	Verp.-Einh.				
			blank	Sn	Ni	L 1 mm	L 2 mm	L 3 mm				Chain form	loose piece			
			Finishing											Tab thick- ness	Tab width	Inden- tation
			un- plated	Sn	Ni											
Supply condition Q = transverse transport / Side feed L = longitudinal transport / End feed	Part number	Material														
													x 1000			

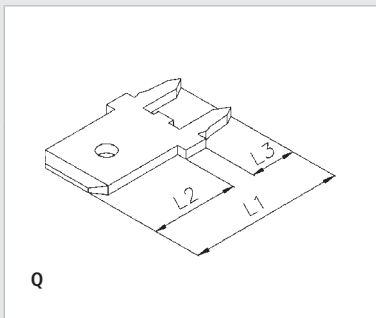

RMB 6006 P 1,3-6,3	CuSn				14,0	8,0	4,0	0,8	6,3	DIN	15	2
	CuZn	●	●									
	Fe											
RMB 6006.002 P 1,3-6,3 Für Gehäuse For housings	CuSn				16,0	10,0	4,0	0,8	6,3	DIN	15	2
	CuZn		●									
	Fe											
RMB 6006.100 P 1,3-6,3	CuZn		●		14,0	8,0	4,0	0,8	6,3	DIN	15	
			selectiv selective									

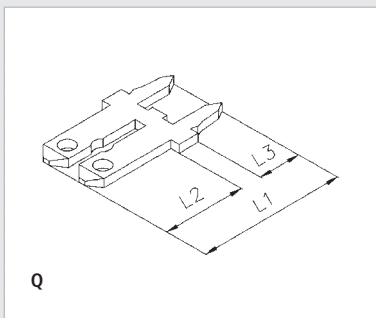

RMB 6007.002 P 1,3-6,3	CuSn				14,0	8,0	4,0	0,8	6,3	DIN	15	2
	CuZn	○	○						2 x 2,8			
	Fe											
RMB 6007.003 P 1,3-6,3	CuSn				14,0	8,0	4,0	0,5	6,3	DIN	15	2
	CuZn	○	○						2 x 2,8			
	Fe											

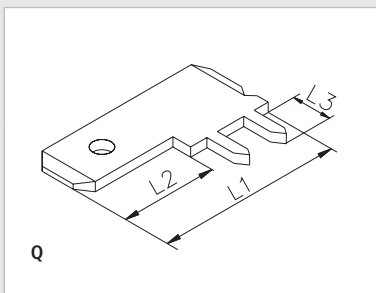

RMB 6201 P 1,2-6,3	CuSn				18,0	8,0	4,0	0,8	6,3	DIN	10	1
	CuZn	○	●									
	Fe											

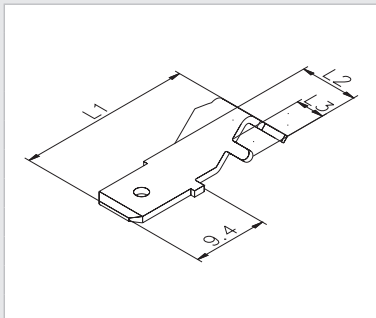

RM 5980.001 P 1,2-6,3	CuSn				20,4	8,0	2,8	0,8	6,3	DIN		1
	CuZn	○	○									
	Fe											

● Standard-Artikel / Standard parts ○ lieferbar auf Anfrage / available on request

Flachstecker

Flachstecker zum Anschweißen, Steckbreite **6,3 mm**

Tabs

Weld tabs width **6,3 mm**

Bauform Q = Quertransport L = Längstransport	Artikel-Nummer	Material	Veredlung			Abmessungen			Steckdicke	Win- kel	Rast- loch	Verp.-Einh.	
			blank	Sn	Ni	L 1 mm	L 2 mm	L 3 mm				Chain form	loose piece
			Finishing										
Supply condition Q = transverse transport / Side feed L = longitudinal transport / End feed	Part number	Material	un- plated	Sn	Ni	Dimensions		Tab thick- ness	Angle	Inden- tation	x 1000		

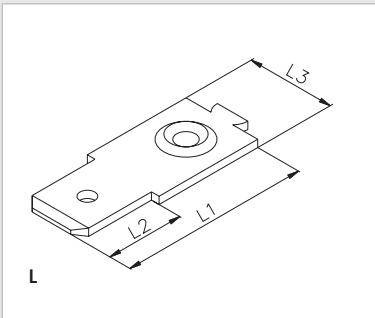

RMB 7942 VS 6,3	CuZn Fe				●	19,0	8,0	8,0	0,8	0°	DIN	9	
------------------------	------------	--	--	--	---	------	-----	-----	-----	----	-----	---	--

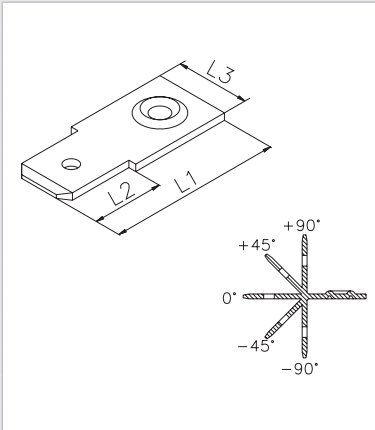

RM 6015 VS 6,3	CuZn Fe				○	19,0	8,0	8,0	0,8	0°	DIN		1
RM 6015.645 VS 6,3	CuZn Fe				○		8,0	8,0	0,8	+45°	DIN		1
RM 6015.845 VS 6,3	CuZn Fe				○		8,0	8,0	0,8	-45°	DIN		1
RM 6015.290 VS 6,3	CuZn Fe				○		8,0	8,0	0,8	+90°	DIN		1
RM 6015.690 VS 6,3	CuZn Fe				○		8,0	8,0	0,8	-90°	DIN		1

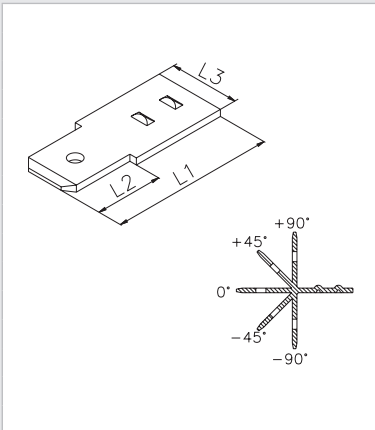

RM 6015.001 VS 6,3	CuZn Fe				○	19,0	8,0	8,0	0,8	0°	DIN		1
RM 6015.345 VS 6,3	CuZn Fe				○		8,0	8,0	0,8	+45°	DIN		1
RM 6015.245 VS 6,3	CuZn Fe				○		8,0	8,0	0,8	-45°	DIN		1
RM 6015.890 VS 6,3	CuZn Fe				○		8,0	8,0	0,8	+90°	DIN		1
RM 6015.490 VS 6,3	CuZn Fe				○		8,0	8,0	0,8	-90°	DIN		1

● Standard-Artikel / Standard parts ○ lieferbar auf Anfrage / available on request

Flachstecker

Flachstecker zum Anschweißen, Steckbreite **6,3 mm**

Tabs

Weld tabs width **6,3 mm**

Bauform Q = Quertransport L = Längstransport Supply condition Q = transverse transport / Side feed L = longitudinal transport / End feed	Artikel-Nummer Part number	Material	Veredlung			Abmessungen			Steckdicke Tab thickness mm	Win- kel Angle °	Rast- loch Inden- tation	Verp.-Einh.	
			blank	Sn	Ni	L 1 mm	L 2 mm	L 3 mm				Band	lose
			Finishing									Packing unit	
			un- plated	Sn	Ni							Chain form	loose piece
												x 1000	

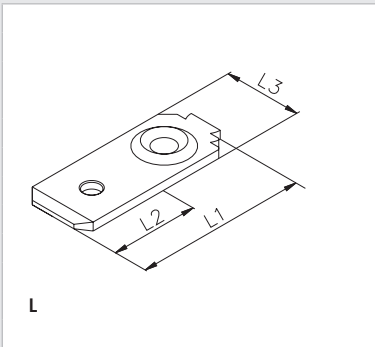

RMB 7926 VS-6,3	CuSn CuZn Fe					15,0	8,1	6,3	0,8	0°	DIN	10	
------------------------	--------------------	--	--	--	--	------	-----	-----	-----	----	-----	----	--

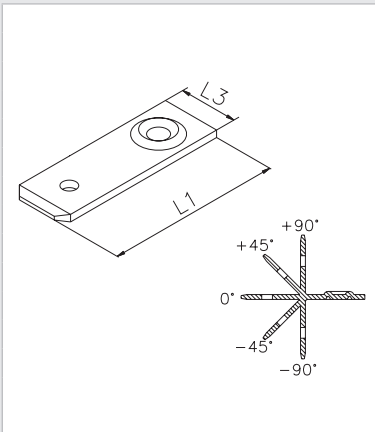

RM 6015.003 VS 6,3	CuSn CuZn Fe					19,0		6,3	0,8	0°	DIN		1
RM 6015.545 VS 6,3	CuSn CuZn Fe							6,3	0,8	+45°	DIN		1
RM 6015.745 VS 6,3	CuSn CuZn Fe							6,3	0,8	-45°	DIN		1
RM 6015.190 VS 6,3	CuSn CuZn Fe							6,3	0,8	+90°	DIN		1
RM 6015.390 VS 6,3	CuSn CuZn Fe							6,3	0,8	-90°	DIN		1

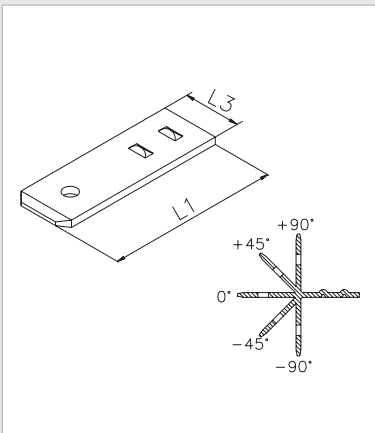

RM 6015.002 VS 6,3	CuSn CuZn Fe					19,0		6,3	0,8	0°	DIN		1
RM 6015.445 VS 6,3	CuSn CuZn Fe							6,3	0,8	+45°	DIN		1
RM 6015.145 VS 6,3	CuSn CuZn Fe							6,3	0,8	-45°	DIN		1
RM 6015.790 VS 6,3	CuSn CuZn Fe							6,3	0,8	+90°	DIN		1
RM 6015.590 VS 6,3	CuSn CuZn Fe							6,3	0,8	-90°	DIN		1

● Standard-Artikel / Standard parts ○ lieferbar auf Anfrage / available on request

Flachstecker

Flachstecker zum Befestigen und Anschweißen, Steckbreite **4,8 mm**

Tabs

Tabs for fixing and welding, width **4,8 mm**

Bauform Q = Quertransport L = Längstransport	Artikel-Nummer	Material	Veredlung			Abmessungen			Bohrungs- Ø	Steck- dicke	Win- kel	Rast- loch	Verp.-Einh. lose
			blank	Sn	Ni	L 1 mm	L 2 mm	L 3 mm					
			Finishing										
Supply condition Q = transverse transport / Side feed L = longitudinal transport / End feed	Part number	Material	un- plated	Sn	Ni	Dimensions			Drill hole Ø	Tab thick- ness	Angle	Inden- tation	Packing unit loose piece
									D 1 mm	mm	°		x 1000

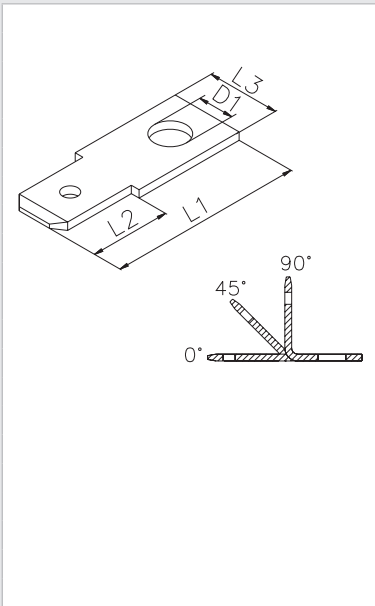

RM 6080 A 3-4,8	CuZn Fe	○ ○	○ ○	○ ○	17,5	7,2	6,5	3,2	0,8	0°	DIN	1
RM 6080 A 4-4,8	CuZn Fe	○ ○	○ ○	○ ○	17,5	7,2	6,5	4,3	0,8	0°	DIN	1
RM 6080.045 A 3-4,8	CuZn Fe	○ ○	○ ○	○ ○	7,2	6,5	3,2	0,8	0,8	45°	DIN	1
RM 6080.045 A 4-4,8	CuZn Fe	○ ○	○ ○	○ ○	7,2	6,5	4,3	0,8	0,8	45°	DIN	1
RM 6080.090 A 2,2-4,8	CuZn Fe	○ ○	○ ○	○ ○	7,2	6,5	2,2	0,8	0,8	45°	DIN	1
RM 6080.090 A 3-4,8	CuZn Fe	○ ○	○ ○	○ ○	7,2	6,5	3,2	0,8	0,8	90°	DIN	1
RM 6080.090 A 4-4,8	CuZn Fe	○ ○	○ ○	○ ○	7,2	6,5	4,3	0,8	0,8	90°	DIN	1

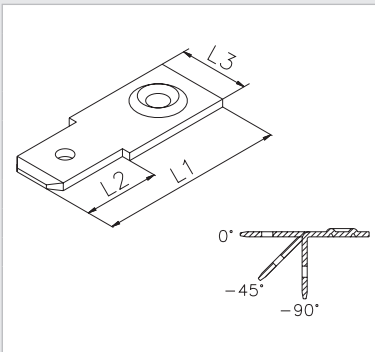

RM 6059 VS 4,8	Fe			○	17,0	7,4	6,5		0,8	0°		2
RM 6059.645 VS 4,8	Fe			○	7,4	6,5			0,8	-45°		2
RM 6059.690 VS 4,8	Fe			○	7,4	6,5			0,8	-90°		2

● Standard-Artikel / Standard parts ○ lieferbar auf Anfrage / available on request

Flachstecker

Flachstecker zum Befestigen, Steckbreite **6,3 mm**

Tabs

Tabs for fixing, width **6,3 mm**

Bauform Q = Quertransport L = Längstransport	Artikel-Nummer	Material	Veredlung			Abmessungen			Bohrungs- Ø	Steck- dicke	Win- kel	Rast- loch	Verp.-Einh. lose
			blank	Sn	Ni	L 1 mm	L 2 mm	L 3 mm					
			Finishing										
Supply condition Q = transverse transport / Side feed L = longitudinal transport / End feed	Part number	Material	un- plated	Sn	Ni	Dimensions			Drill hole Ø	Tab thick- ness	Angle	Inden- tation	Packing unit loose piece
									D 1 mm	mm	°		x 1000

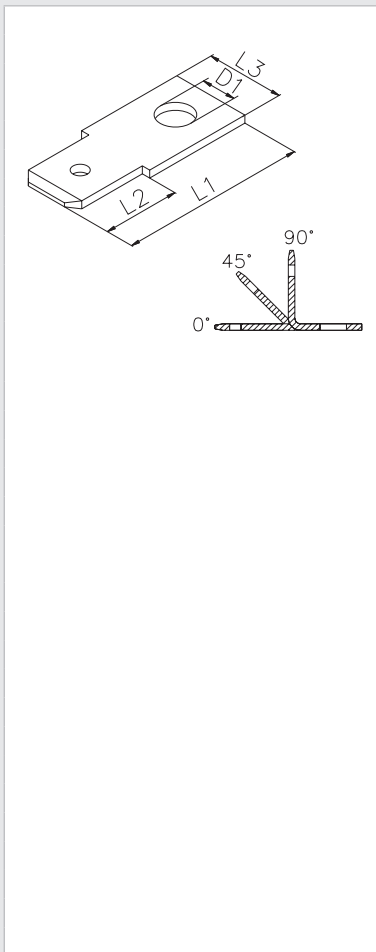

RM 6015 A 3-6,3	CuZn Fe	○	●			19,0	8,1	8,0	3,2	0,8	0°	DIN	1
RM 6015 A 4-6,3	CuZn Fe	○	●		○	19,0	8,1	8,0	4,3	0,8	0°	DIN	1
RM 6015 A 5-6,3	CuZn Fe	○	○		○	19,0	8,1	8,0	5,3	0,8	0°	DIN	1
RM 6015.045 A 3-6,3	CuZn Fe	○	○		○	8,1	8,0	3,2	0,8	45°	DIN	1	
RM 6015.045 A 4-6,3	CuZn Fe	●	○		●	8,1	8,0	4,3	0,8	45°	DIN	1	
RM 6015.045 A 5-6,3	CuZn Fe	●	●		○	8,1	8,0	5,3	0,8	45°	DIN	1	
RM 6015.045 A 6-6,3	CuZn Fe	●	●		○	8,1	8,0	6,3	0,8	45°	DIN	1	
RM 6015.090 A 3-6,3	CuZn Fe	○	○		○	8,1	8,0	3,2	0,8	90°	DIN	1	
RM 6015.090 A 3,5-6,3	CuZn Fe	○	○		○	8,1	8,0	3,7	0,8	90°	DIN	1	
RM 6015.090 A 4-6,3	CuZn Fe	○	○		○	8,1	8,0	4,3	0,8	90°	DIN	1	
RM 6015.090 A 5-6,3	CuZn Fe	○	○			8,1	8,0	5,3	0,8	90°	DIN	1	

● Standard-Artikel / Standard parts ○ lieferbar auf Anfrage / available on request

Flachstecker

Flachstecker zum Befestigen, Steckbreite **6,3 mm**

Tabs

Tabs for fixing, width **6,3 mm**

Bauform Q = Quertransport L = Längstransport	Artikel-Nummer	Material	Veredlung			Abmessungen			Bohrungs- Ø	Steck- dicke	Win- kel	Rast- loch	Verp.-Einh. lose
			blank	Sn	Ni	L 1 mm	L 2 mm	L 3 mm					
			Finishing										
Supply condition Q = transverse transport / Side feed L = longitudinal transport / End feed	Part number	Material	un- plated	Sn	Ni	Dimensions			Drill hole Ø	Tab thick- ness	Angle	Inden- tation	Packing unit loose piece
									D 1 mm	mm	°		x 1000

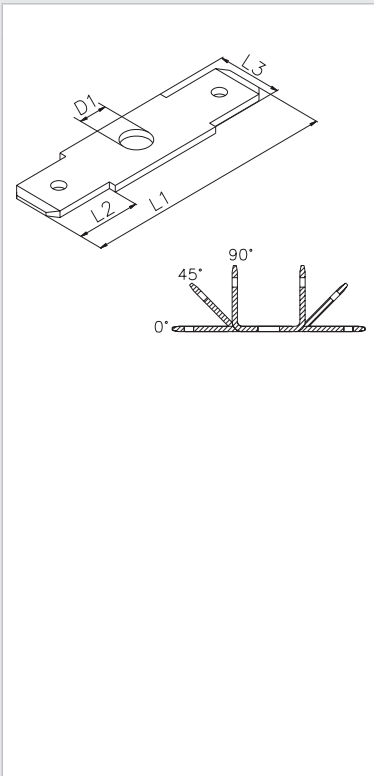

RM 6129 DSL 3-6,3	CuZn Fe	○	○		30	8,1	8,0	3,1	0,8	0°	DIN	1
RM 6129 A 4-6,3	CuZn Fe	○	○		30	8,1	8,0	4,3	0,8	0°	DIN	1
RM 6129 A 5-6,3	CuZn Fe	○	○		30	8,1	8,0	5,3	0,8	0°	DIN	1
RM 6129.045 DSL 3-6,3	CuZn Fe	○	○			8,1	8,0	3,1	0,8	45°	DIN	1
RM 6129.045 A 4-6,3	CuZn Fe	○	○			8,1	8,0	4,3	0,8	45°	DIN	1
RM 6129.045 A 5-6,3	CuZn Fe	○	○			8,1	8,0	5,3	0,8	45°	DIN	1
RM 6129.090 DSL 3-6,3	CuZn Fe	○	○			8,1	8,0	3,1	0,8	90°	DIN	1
RM 6129.090 A 4-6,3	CuZn Fe	○	○			8,1	8,0	4,3	0,8	90°	DIN	1
RM 6129.090 A 5-6,3	CuZn Fe	○	○			8,1	8,0	5,3	0,8	90°	DIN	1

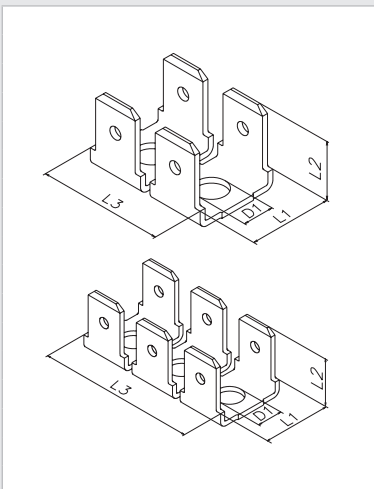

RM 6129/2 A 4-6,3	CuZn	○	○		11,6	8,1	17,5	4,3	0,8	0°	DIN	1
RM 6129.075/2 A 4-6,3	CuZn	○	○			8,1	17,5	4,3	0,8	75°	DIN	1
RM 6129.090/2 A 4-6,3	CuZn	○	○			8,1	17,5	4,3	0,8	90°	DIN	1
RM 6129.045/3 DSL 3-6,3	CuZn	○	○			8,1	27,0	3,0	0,8	45°	DIN	1
RM 6129.090/3 A 4-6,3	CuZn	○	○			8,1	27,0	4,3	0,8	90°	DIN	1

● Standard-Artikel / Standard parts ○ lieferbar auf Anfrage / available on request

Krallenkabelschuhe

Krallenkabelschuhe ohne Isolationscrimp

Open barrel terminals

Open barrel terminals without insulation crimp

Bauform Q = Quertransport L = Längstransport	Artikel-Nummer	Leiter- quer- schnitt	Material	Veredlung			Außen Ø	Bohrungs- Ø	Länge	Material- stärke	Verp.-Einh. Band
				blank	Sn	Ni					
				Finishing							
Supply condition Q = transverse transport / Side feed L = longitudinal transport / End feed	Part number	Wire size	Material	un- plated	Sn	Ni	d 3 mm	d 2 mm	L mm	mm	x 1000

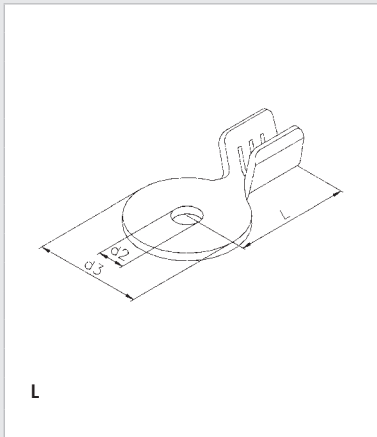

RSB 7727 A 1,7-1	0,5-1	CuSn				6,8	1,70	7,5	0,5	20
	20-18	CuZn	○	●						
		Fe			○					
RSB 7727 A 2,6-1	0,5-1	CuSn				6,8	2,80	7,5	0,5	20
	20-18	CuZn	○	○						
		Fe			○					
RSB 7727 A 3-1	0,5-1	CuSn				6,8	3,20	7,5	0,5	20
	20-18	CuZn	○	○						
		Fe			○					
RSB 7727 A 3,5-1	0,5-1	CuSn				6,8	3,70	7,5	0,5	20
	20-18	CuZn	○	○						
		Fe			○					
RSB 7727 A 4-1	0,5-1	CuSn				6,8	4,30	7,5	0,5	20
	20-18	CuZn	●	●						
		Fe			○					

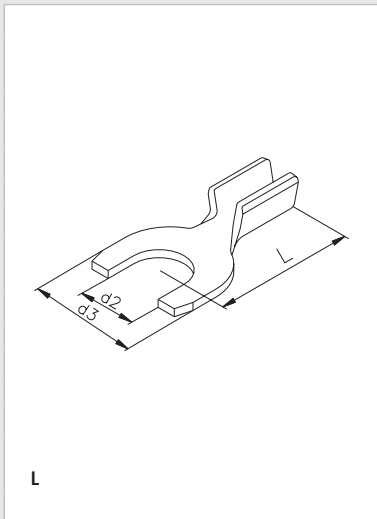

RSB 7737.001 C 3,5-0,7	0,25-0,7	CuSn				6,5	3,70	8,8	0,5	24
	22-20	CuZn	○	○						
		Fe								
RSB 7921 C 3,5-1	0,5-1	CuSn				6,4	3,60	11,0	0,5	15
	20-18	CuZn	○	○						
		Fe								
RSB 7921 C 4-1	0,5-1	CuSn				6,4	4,20	11,0	0,5	15
	20-18	CuZn	○	○						
		Fe								
RSB 7779 C 5-6	>3-5	CuSn				9,5	5,50	15,5	0,8	4,5
	12-10	CuZn	●	○						
		Fe								
RSB 7779 C 5-10	>5-10	CuSn				9,3	5,50	15,5	1,0	2
	10-7	CuZn	●	○						
		Fe								
RSB 7779 C 6-10	>5-10	CuSn				9,3	6,20	15,5	1,0	2
	10-7	CuZn	●	○						
		Fe								

● Standard-Artikel / Standard parts ○ lieferbar auf Anfrage / available on request

Krallenkabelschuhe

Krallenkabelschuhe mit Isolationscrimp

Open barrel terminals

Open barrel terminals with insulation crimp

Bauform Q = Quertransport L = Längstransport	Artikel-Nummer	DIN	Leiterquerschnitt	Material	Veredlung			Außen Ø	Bohrungs-Ø	Länge	Materialstärke	Verp.-Einh. Band
					blank	Sn	Ni					
					Finishing							
Supply condition Q = transverse transport / Side feed L = longitudinal transport / End feed	Part number		Wire size	Material	un-plated	Sn	Ni	d 3 mm	d 2 mm	L mm	mm	x 1000

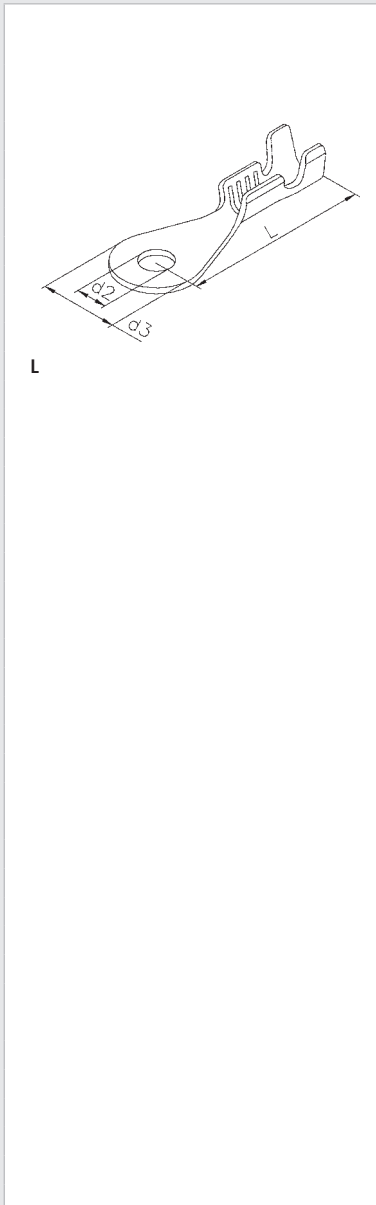

RSB 7813 A 3-0,5		0,14-0,5 26-20	CuSn				5,0	3,2	8,5	0,3	22
			CuZn	○	●						
			Fe								
RSB 7716.001 A 3-1		0,5-1 20-18	CuSn				6,3	3,2	8,8	0,5	14
			CuZn	●	●						
			Fe			●					
RSB 7716.001 A 3,5-1		0,5-1 20-18	CuSn				6,3	3,7	8,8	0,5	14
			CuZn	●	●						
			Fe			○					
RSB 7716.001 A 4-1		0,5-1 20-18	CuSn				6,3	4,3	8,8	0,5	14
			CuZn	●	●						
			Fe			●					
RSB 7206 A 3-1	46225 A 3-1	>0,25-1 22-14	CuSn	○	○		8,0	3,2	18,0	0,6	6
			CuZn	○	●						
			Fe			○					
RSB 7206 A 3,5-1		0,25-1 24-18	CuSn	○	○		8,0	3,7	18,0	0,6	6
			CuZn	○	○						
			Fe			○					
RSB 7206 A 4-1	46225 A 4-1	0,25-1 24-18	CuSn	○	○		8,0	4,3	18,0	0,6	6
			CuZn	●	●						
			Fe			●					
RSB 7207 A 5-1	46225 A 5-1	0,25-1 24-18	CuSn	○	○		9,5	5,3	17,0	0,6	6
			CuZn	●	●						
			Fe			●					
RSB 8202 A 6-1	46225 A 6-1	0,5-1 20-18	CuZn	○	●		12,0	6,5	22,0	0,6	6
			CuSn	○	○						
			Fe								
RSB 7881 A 3-1,5		0,5-1,5 18-16	CuSn				8,8	3,2	12,7	0,5	6
			CuZn	○	○						
			Fe								
RSB 7881 A 3,5-1,5		0,5-1,5 18-16	CuSn				8,8	3,7	12,7	0,5	6
			CuZn	●	○						
			Fe								
RSB 7881 A 4-1,5		0,5-1,5 18-16	CuSn				8,8	4,3	12,7	0,5	6
			CuZn	●	○						
			Fe								
RSB 7881 A 5-1,5		0,5-1,5 18-16	CuSn				8,8	5,3	12,7	0,5	6
			CuZn	○	○						
			Fe								
RSB 7881 A 6-1,5		0,5-1,5 18-16	CuSn				8,8	6,5	12,7	0,5	6
			CuZn	●	●						
			Fe								

● Standard-Artikel / Standard parts ○ lieferbar auf Anfrage / available on request

Krallenkabelschuhe

Krallenkabelschuhe mit Isolationscrimp

Open barrel terminals

Open barrel terminals with insulation crimp

Bauform Q = Quertransport L = Längstransport	Artikel-Nummer	DIN UL	Leiterquer- schnitt	Material	Veredlung			Außen Ø	Bohrungs- Ø	Länge	Material- stärke	Verp.-Einh. Band
					blank	Sn	Ni					
					Finishing							
Supply condition Q = transverse transport / Side feed L = longitudinal transport / End feed	Part number		Wire size	Material	un- plated	Sn	Ni	d 3 mm	d 2 mm	L mm	mm	x 1000

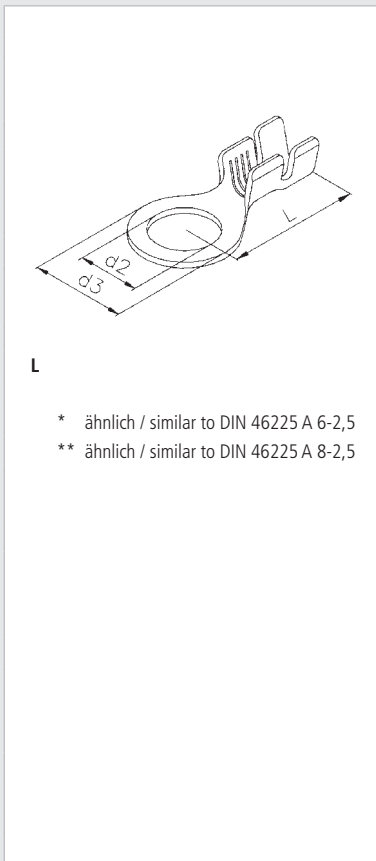

RSB 8203 A 6-2,5	*	1-2,5 16-14	CuZn	○	●		12,0	6,5	22,0	0,6	5,5
			CuSn	○	○						
RSB 8204 A 8-2,5	**	1-2,5 16-14	CuZn	○	●		14,0	8,4	21,0	0,6	4,8
			CuSn								
RSB 7208 A 3-2,5	46225 A 3-2,5	>1-3 16-14	CuSn	○	○		8,0	3,2	18,0	0,6	5
			CuZn	○	○						
			Fe			○					
RSB 7208 A 4-2,5	46225 A 4-2,5	>1-3 16-14	CuSn	○	○		8,0	4,3	18,0	0,6	5
			CuZn	●	●						
			Fe			●					
RSB 7209 A 5-2,5	46225 A 5-2,5	>1-3 16-14	CuSn	○	○		9,5	5,3	17,0	0,6	5
			CuZn	●	●						
			Fe			○					
RSB 7209 A 6-2,5		>1-3 16-14	CuSn	○	○		9,5	6,5	17,0	0,6	5
			CuZn	○	●						
			Fe			○					
RSB 7877 A 3-4		1-2,5 16-14	CuSn				8,7	3,2	15,4	0,8	5
			CuZn	○	○						
			Fe								
RSB 7877 A 3,5-4		1-2,5 16-14	CuSn				8,7	3,7	15,4	0,8	5
			CuZn	○	○						
			Fe								
RSB 7877 A 4-4		1-2,5 16-14	CuSn				8,7	4,3	15,4	0,8	5
			CuZn	●	●						
			Fe								
RSB 7877 A 5-4		1-2,5 16-14	CuSn				8,7	5,3	15,4	0,8	5
			CuZn	○	○						
			Fe								

● Standard-Artikel / Standard parts ○ lieferbar auf Anfrage / available on request

Krallenkabelschuhe

Krallenkabelschuhe mit Isolationscrimp

Open barrel terminals

Open barrel terminals with insulation crimp

Bauform Q = Quertransport L = Längstransport	Artikel-Nummer	DIN UL	Leiterquer- schnitt	Material	Veredlung			Außen Ø	Bohrungs- Ø	Länge	Material- stärke	Verp.-Einh. Band
					blank	Sn	Ni					
					un- plated	Sn	Ni					
Supply condition Q = transverse transport / Side feed L = longitudinal transport / End feed	Part number		Wire size	Material	Finishing			Outside Ø	Drill hole Ø	Length	Material thickness	Packing unit Chain form
			mm ² AWG					d 3 mm	d 2 mm	L mm	mm	x 1000

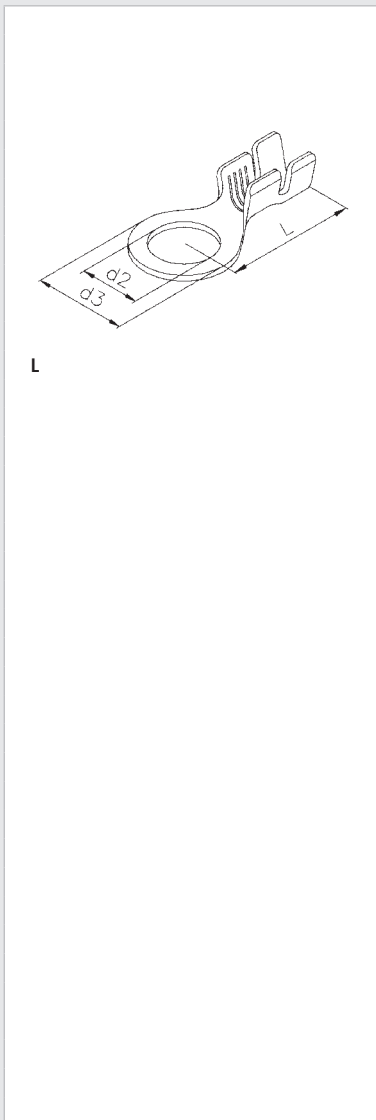

RSB 7788 A 4-6	●	>2,5-6 12-10	CuSn	○	○	11,8	4,3	20,0	0,8	3
			CuZn	○	●					
			Fe							
RSB 7788 A 5-6	●	>2,5-6 12-10	CuSn	○	○	11,8	5,3	20,0	0,8	3
			CuZn	○	●					
			Fe							
RSB 7788 A 6-6	●	>2,5-6 12-10	CuSn	○	○	11,8	6,4	20,0	0,8	3
			CuZn	○	●					
			Fe							
RSB 7788 A 8-6	●	>2,5-6 12-10	CuSn	○	○	11,8	8,4	20,0	0,8	3
			CuZn	○	●					
			Fe							
RSB 8201 A 6-6	46225 A 6-6	2,5-6 12-10	CuZn	○	●	12,0	6,5	25,0	0,8	3
			CuSn	○	○					
			Fe							
RSB 7728.002 A 5-10		6-10 10-7	CuSn			16,0	5,3	24,5	1,2	1
			CuZn	○	○					
			Fe							
RSB 7728.002 A 6-10		6-10 10-7	CuSn			16,0	6,5	24,5	1,2	1
			CuZn	○	○					
			Fe							
RSB 7728.002 A 8-10		6-10 10-7	CuSn			16,0	8,5	24,5	1,2	1
			CuZn	○	○					
			Fe							
RSB 7728.002 A 10-10		6-10 10-7	CuSn			16,0	10,5	24,5	1,2	1
			CuZn	○	○					
			Fe							
RSB 8200 A 6-10	46225 A 6-10	6-10 10-8	CuZn	○	●	12,0	6,5	23,0	1,0	2
			CuSn	○	○					
			Fe							
RSB 8044 A 6-20		>10-20 7-4	CuSn			20,0	6,5	26,5	1,8	1
			CuZn	○	○					
			Fe							
RSB 8044 A 8,5-20		>10-20 7-4	CuSn			20,0	8,5	26,5	1,8	1
			CuZn	●	○					
			Fe							
RSB 8044 A 10-20		>10-20 7-4	CuSn			20,0	10,5	26,5	1,8	1
			CuZn	○	○					
			Fe							

● Standard-Artikel / Standard parts ○ lieferbar auf Anfrage / available on request

Krallenkabelschuhe

Krallenkabelschuhe mit Isolationscrimp

Open barrel terminals

Open barrel terminals with insulation crimp

Bauform Q = Quertransport L = Längstransport	Artikel-Nummer	DIN UL	Leiterquer- schnitt	Material	Veredlung			Außen Ø	Bohrungs- Ø	Länge	Material- stärke	Verp.-Einh. Band
					blank	Sn	Ni					
					Finishing							
Supply condition Q = transverse transport / Side feed L = longitudinal transport / End feed	Part number		Wire size	Material	un- plated	Sn	Ni	d 3 mm	d 2 mm	L mm	mm	x 1000

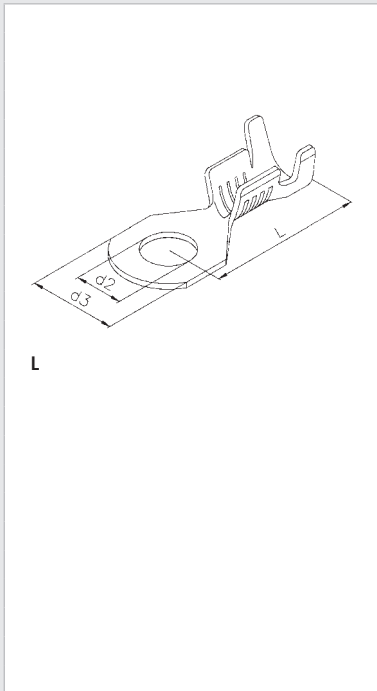

RSB 7716.002 A 2,7-1	0,5-1 20-18	CuSn				4,5	2,7	8,8	0,5	16	
		CuZn	○	○							
		Fe			○						
	RSB 7881.001 A 3-1,5	0,5-1,5 18-16	CuSn				7,8	3,2	12,7	0,5	6
			CuZn	○	○						
			Fe								
	RSB 7881.001 A 3,5-1,5	0,5-1,5 18-16	CuSn				7,8	3,7	12,7	0,5	6
			CuZn	○	○						
			Fe								
	RSB 7881.001 A 4-1,5	0,5-1,5 18-16	CuSn				7,8	4,3	12,7	0,5	6
CuZn			●	●							
Fe											
RSB 7788.001 A 4-6	>2,5-6 12-10	CuSn				9,0	4,3	20,0	0,8	3	
		CuZn	○	○							
		Fe									
RSB 7788.001 A 5-6	>2,5-6 12-10	CuSn				9,0	5,3	20,0	0,8	3	
		CuZn	○	●							
		Fe									
RSB 7788.001 A 6-6	>2,5-6 12-10	CuSn				9,0	6,4	20,0	0,8	3	
		CuZn	○	○							
		Fe									
RSB 8044.001 A 6-20	>10-20 7-4	CuSn				15,0	6,5	26,5	1,8	1	
		CuZn	○	○							
		Fe									

● Standard-Artikel / Standard parts ○ lieferbar auf Anfrage / available on request

Krallenkabelschuhe

Krallenkabelschuhe Sonderausführungen

Open barrel terminals

Open barrel terminals special types

Bauform Q = Quertransport L = Längstransport	Artikel-Nummer	DIN UL	Leiterquer- schnitt	Material	Veredlung			Außen Ø	Bohrungs- Ø	Länge	Material- stärke	Verp.-Einh. Band
					blank	Sn	Ni					
					Finishing							
Supply condition Q = transverse transport / Side feed L = longitudinal transport / End feed	Part number		Wire size	Material	un- plated	Sn	Ni	d 3 mm	d 2 mm	L mm	mm	x 1000
			mm ² AWG									

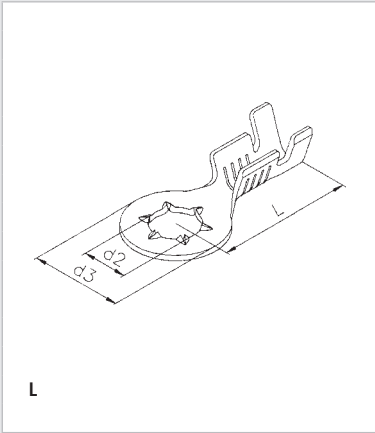

RSB 8134.010 V 4-1,5		0,5-1,5 20-16	CuSn				8,8	4,3	12,7	0,5	6
			CuZn								
			Fe	●	○						
RSB 7923.002 V 3,5-1	●	0,5-1 22-18	CuSn	○	○		8,8	3,8	15,5	0,6	7
			CuZn	○	○						
			Fe			○					
RSB 7923.002 V 5-1	●	0,5-1 22-18	CuSn	○	○		8,8	5,2	15,5	0,6	7
			CuZn	○	○						
			Fe			●					

● Standard-Artikel / Standard parts ○ lieferbar auf Anfrage / available on request

Krallenkabelschuhe

Krallenkabelschuhe C-Form

Open barrel terminals

Open barrel terminals C-Type

Bauform Q = Quertransport L = Längstransport	Artikel-Nummer	DIN	Leiterquer- schnitt	Material	Veredlung			Außen Ø	Bohrungs- Ø	Länge	Material- stärke	Verp.-Einh. Band
					blank	Sn	Ni					
					un- plated	Sn	Ni					
Supply condition Q = transverse transport / Side feed L = longitudinal transport / End feed	Part number		Wire size	Material	Finishing			Outside Ø	Drill hole Ø	Length	Material thickness	Packing unit Chain form
			mm ² AWG					d 3 mm	d 2 mm	L mm	mm	x 1000

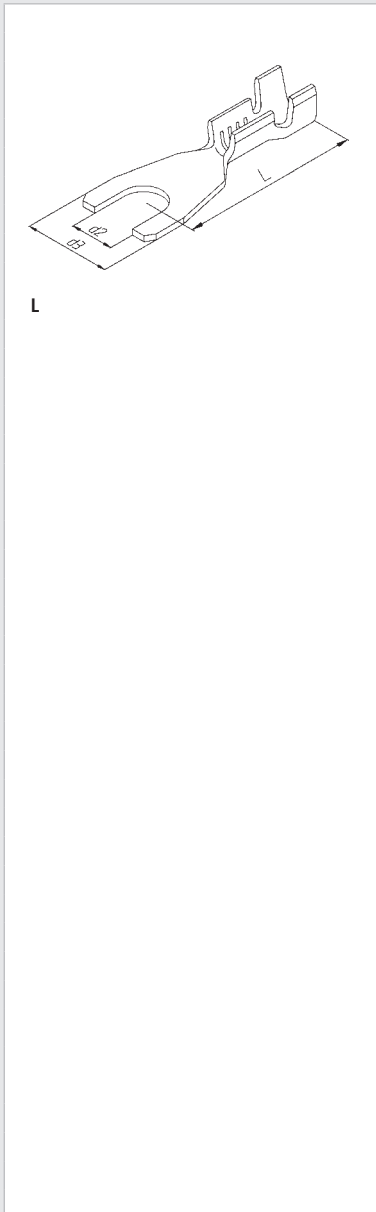

RSB 7738 C 3-1		0,5-1 20-18	CuSn				5,9	3,20	9,0	0,5	12
			CuZn	●	●						
			Fe								
RSB 7830 C 3-1		0,5-1 20-18	CuSn				8,0	3,20	18,0	0,6	5
			CuZn	○	○						
			Fe								
RSB 7830.001 C 3-1		0,5-1 20-18	CuSn				6,8	3,20	18,0	0,6	5
			CuZn	○	○						
			Fe								
RSB 7830.001 C 3,5-1		0,5-1 20-18	CuSn				6,8	3,70	18,0	0,6	5
			CuZn	○	●						
			Fe								
RSB 7830 C 4-1		0,5-1 20-18	CuSn				8,0	4,30	18,0	0,6	5
			CuZn	●	○						
			Fe								
RSB 7830.001 C 4-1		0,5-1 20-18	CuSn				6,8	4,30	18,0	0,6	5
			CuZn	○	○						
			Fe								
RSB 7830 C 5-1		0,5-1 20-18	CuSn				8,0	5,30	17,5	0,6	5
			CuZn	○	○						
			Fe								
RSB 7843 C 3-2,5		>1-2,5 16-14	CuSn				8,0	3,20	18,0	0,6	5
			CuZn	○	○						
			Fe								
RSB 7843.001 C 3-2,5		>1-2,5 16-14	CuSn				6,8	3,20	18,0	0,6	5
			CuZn	○	○						
			Fe								
RSB 7843 C 3,5-2,5		>1-2,5 16-14	CuSn				8,0	3,70	18,0	0,6	5
			CuZn	○	○						
			Fe								
RSB 7843.001 C 3,5-2,5		>1-2,5 16-14	CuSn				6,8	3,70	18,0	0,6	5
			CuZn	○	○						
			Fe								
RSB 7843.001 C 4-2,5		>1-2,5 16-14	CuSn				6,8	4,30	18,0	0,6	5
			CuZn	○	●						
			Fe								
RSB 7843 C 4-2,5	46225 B 4-2,5	>1-2,5 16-14	CuSn				8,0	4,30	18,0	0,6	5
			CuZn	●	●						
			Fe								
RSB 7843 C 5-2,5		>1-2,5 16-14	CuSn				8,0	5,30	17,5	0,6	5
			CuZn	●	○						
			Fe								

● Standard-Artikel / Standard parts ○ lieferbar auf Anfrage / available on request

Aderendhülsen End splices

Bauform Q = Quertransport L = Längstransport Supply condition Q = transverse transport / Side feed L = longitudinal transport / End feed	Artikel-Nummer	Freigabens. Seite 7/8	Leiterquerschnitt	Material	Veredlung			Länge	Materialstärke	Verp.-Einh. Band
	Part number	Approvals. s. page 7/8	Wire size	Material	Finishing			Length	Material thickness	Packing unit Chain form
					blank	Sn	Ni			
			mm ² AWG		un-plated	Sn	Ni	L 2 mm	mm	x 1000

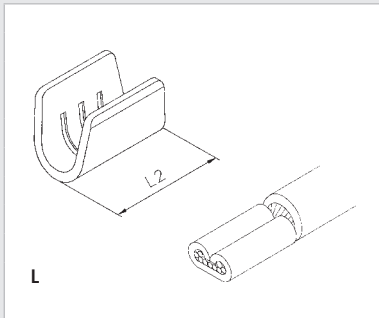

RSB 7838 V-0,75	0,25-0,75	CuZn	○	●		3,7	0,3	99
	24-20	Z 8 C 17	○					

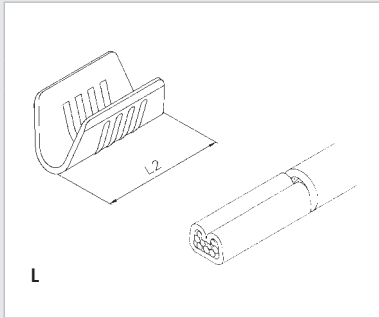

RSB 7792.002 V-1,5	● 1-2	CuZn	●	●		6,0	0,3	40
	● 18-14	Fe			●			

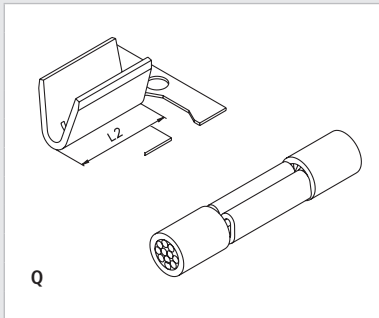

RSB 7825.001 V-1	0,5-1,5	CuZn	●	○		5,8	0,3	16
	20-16	Fe			○			
RSB 8059 V-2,5	1,5-2,5	CuZn	○	○		6,4	0,4	6
	16-14	Fe			○			

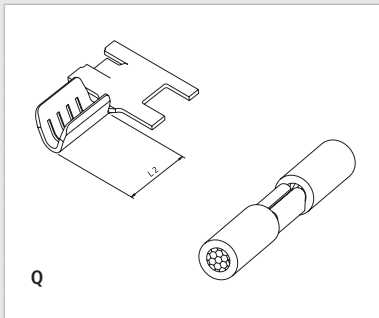

RSB 8236	0,5-1	CuZn	●	○		4,0	0,3	26
	22-18							

● Standard-Artikel / Standard parts ○ lieferbar auf Anfrage / available on request

Aderendhülsen End splices

Bauform Q = Quertransport L = Längstransport	Artikel-Nummer	DIN UL	Leiterquer- schnitt	Material	Veredlung			Länge	Material- stärke	Verp.-Einh. Band
					blank	Sn	Ni			
Supply condition Q = transverse transport / Side feed L = longitudinal transport / End feed	Part number	DIN UL	Wire size	Material	Finishing			Length	Material thickness	Packing unit Chain form
					un- plated	Sn	Ni			
			mm ² AWG					L 2 mm	mm	x 1000

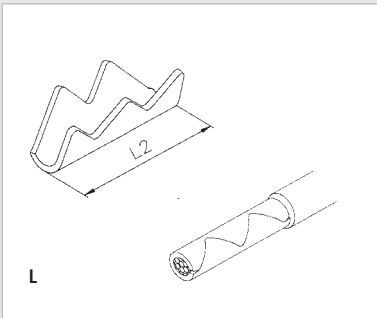

RSB 7999 V-0,5			0,14-0,5 24-20	CuZn	●	●		4,2	0,2	90
				Fe						
RSB 7929 V-1			0,5-1 20-18	CuZn	●	●		6,0	0,25	60
				Fe						

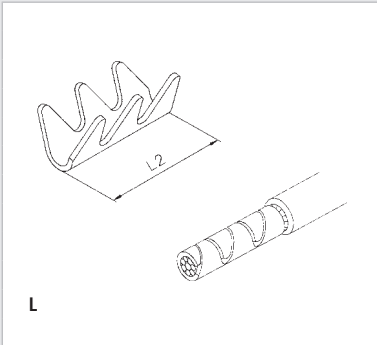

RSB 7849 V-1	46228 T3		0,5-1 20-18	CuZn	●	●		6,1	0,25	60
		●		Fe			●			
RSB 7908 V-1,5			0,5-1,5 20-18	CuZn	●	●		6,0	0,3	40
				Fe						

● Standard-Artikel / Standard parts ○ lieferbar auf Anfrage / available on request

Aderendhülsen End splices

Bauform Q = Quertransport L = Längstransport	Artikel-Nummer	Freigabens. Seite 7/8	Leiterquerschnitt	Material	Veredlung			Länge	Materialstärke	Verp.-Einh. Band
					blank	Sn	Ni			
Supply condition Q = transverse transport / Side feed L = longitudinal transport / End feed	Part number	Approvals. s. page 7/8	Wire size	Material	Finishing			Length	Material thickness	Packing unit Chain form
					un-plated	Sn	Ni			
			mm ² AWG					L 2 mm	mm	x 1000

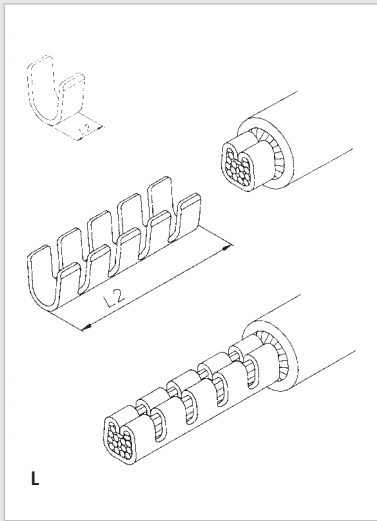

RSB 7735.001 V-1,5		0,5-1,5 20-16	CuZn	●	●	○	(1x) 1,5	0,3	99
			Fe			●	(2x) 3,8		
			CuSn	○	○		(3x) 6,1		
							(4x) 8,4		
							(5x) 10,7		
RSB 7837 V-2,5		1,5-2,5 16-14	CuZn	●	●		(1x) 1,5	0,3	99
			Fe			●	(2x) 3,8		
							(3x) 6,1		
							(4x) 8,4		
							(5x) 10,7		
RSB 7894 V-4	●	2,5-4 14-12	CuZn	●	●		(1x) 1,5	0,25	80
			CuSn	○	○		(2x) 4,0		
							(3x) 6,5		
RSB 7912 V-10		6-10 10-7	CuZn	●	●		(1x) 2,9	0,5	30
			Fe				(2x) 6,65		
							(3x) 10,4		
							(4x) 14,15		

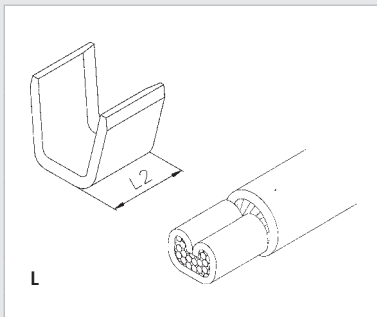

RSB 7791 V-6		2,5-<6 12-10	CuZn	●	●		(1x) 5,0	0,5	25
			CuSn	○	○		(2x) 11,5		
RSB 7791.001 V-6		2,5-6 12-10	CuZn	○	○		(1x) 4,0	0,5	25
			CuSn	○	○		(2x) 10,5		

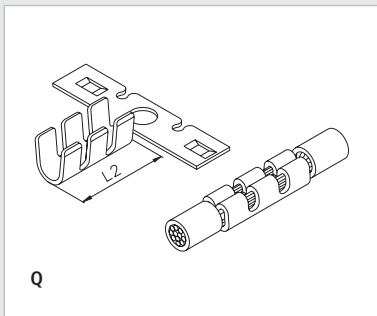

RSB 8006 V-1,5		0,5-1,5 20-16	CuZn	●	●		6,1	0,3	16
			Fe			○			
			Z 8 C 17	○					

● Standard-Artikel / Standard parts ○ lieferbar auf Anfrage / available on request

Aderendhülsen End splices

Bauform Q = Quertransport L = Längstransport	Artikel-Nummer	DIN UL	Leiterquer- schnitt	Material	Veredlung			Länge		Material- stärke	Verp.-Einh. Band
					blank	Sn	Ni	L 1 mm	L 2 mm		
					Finishing						
Supply condition Q = transverse transport / Side feed L = longitudinal transport / End feed	Part number		Wire size	Material	un- plated	Sn	Ni			Material thickness	Packing unit Chain form
			mm ² AWG							mm	x 1000

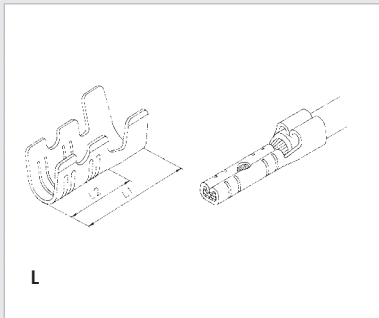

RSB 7770 V-1	46228 T2	0,5-1	CuZn	●	●		11,0	7,0	0,3	25
	B1-7	20-18	Fe			●				
RSB 7771 V-1,5	46228 T2	0,75-1,5	CuZn	●	●		11,0	7,0	0,3	20
	B1,5-7	18-16	Fe			●				
RSB 7832 V-2,5	46228 T2	1,5-2,5	CuZn	●	●		11,0	7,0	0,3	15
	B2,5-7	16-14	Fe			○				

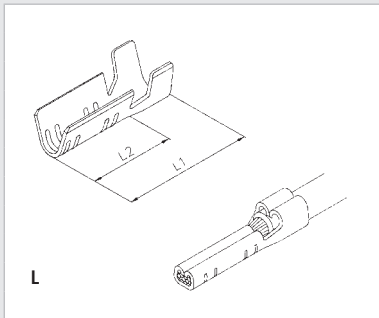

RSB 7752 V-1,5		1-1,5	CuZn	●	●		11,0	7,0	0,3	21
		18-16	Fe			●				

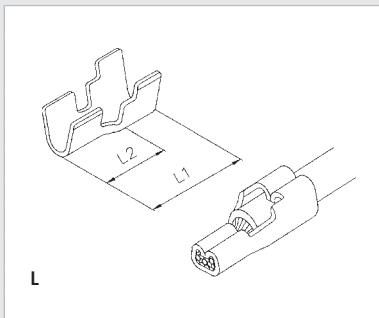

RSB 8011 V-1,5		0,75-<1,5	CuZn	○	○		7,0	2,5	0,3	30
		20-16								

● Standard-Artikel / Standard parts ○ lieferbar auf Anfrage / available on request

Aderendhülsen End splices

Bauform Q = Quertransport L = Längstransport Supply condition Q = transverse transport / Side feed L = longitudinal transport / End feed	Artikel-Nummer	DIN UL	Leiterquer- schnitt	Material	Veredlung			Länge		Material- stärke	Verp.-Einh. Band
	Part number		Wire size	Material	Finishing			Length		Material thickness	Packing unit Chain form
					blank	Sn	Ni	L 1 mm	L 2 mm		
			mm ² AWG		un- plated	Sn	Ni			mm	x 1000

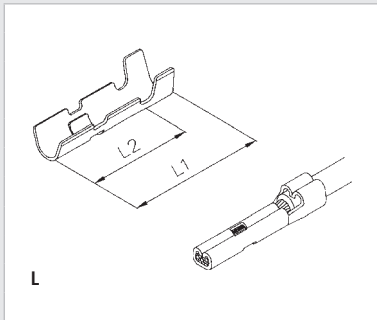

RSB 7806 V-1			0,5-1 20-18	CuZn	○	○		13,0	9,0	0,25	22
---------------------	--	--	----------------	------	---	---	--	------	-----	------	----

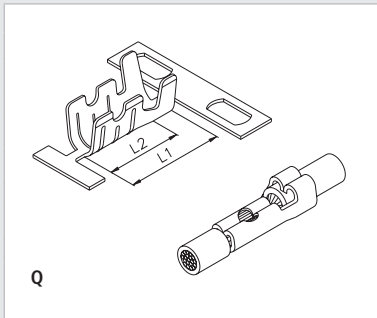

RSB 8061 V-1,5	46228 T2 B 1,5-7		0,75-1,5 18-16	CuZn Fe	○	○	●	7,4	4,6	0,3	4
-----------------------	---------------------	--	-------------------	------------	---	---	---	-----	-----	-----	---

● Standard-Artikel / Standard parts ○ lieferbar auf Anfrage / available on request

Sonderaderendhülsen Special end splices

Bauform Q = Quertransport L = Längstransport	Artikel-Nummer Part number	DIN UL	Leiterquer- schnitt Wire size mm ² AWG	Material	Veredlung			Länge		Material- stärke Material thickness mm	Verp.-Einh. Band Packing unit Chain form x 1000
					blank	Sn	Ni	L 1 mm	L 2 mm		
					Finishing						
Supply condition Q = transverse transport / Side feed L = longitudinal transport / End feed					un- plated	Sn	Ni				

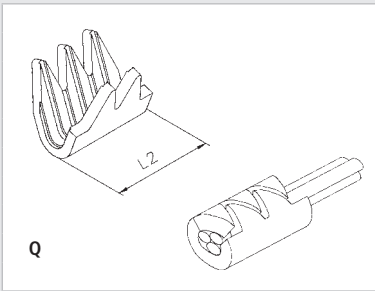

RVB 8131 V-0,6 Für Lackdraht For magnet wire			0,2-0,6 24-20	CuZn	○	○		3,2	0,45	30
---	--	--	------------------	------	---	---	--	-----	------	----

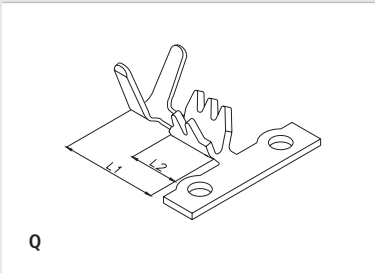

RVB 8131.001 V-06 für Lackdraht For magnet wire			0,2-0,6 24-20	CuZn	○	●		6,7	3,2	0,45	30
--	--	--	------------------	------	---	---	--	-----	-----	------	----

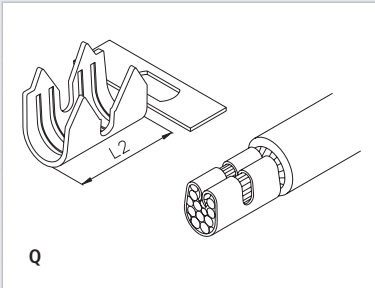

RSB 7884.001 V 0-10			4-10 12-10	CuZn	●	○		10,0	0,3	4
RSB 7884.003 V 0-10			4-10 12-10	CuZn		○		10,0	0,5	4

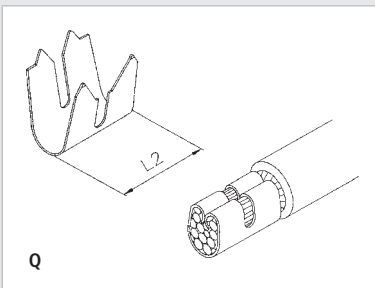

RSB 7884.004 V 0-16			10-16 10-6	CuZn	○	○		10,0	0,5	2,5
----------------------------	--	--	---------------	------	---	---	--	------	-----	-----

● Standard-Artikel / Standard parts ○ lieferbar auf Anfrage / available on request

Rundsteckhülsen Sockets

Bauform Q = Quertransport L = Längstransport Supply condition Q = transverse transport / Side feed L = longitudinal transport / End feed	Artikel-Nummer	Leiterquerschnitt	Material	Veredlung			Innen	Länge		Materialstärke	Verp.-Einh. Band
	Part number	Wire size	Material	Finishing			Inside	Length		Material thickness	Packing unit Chain form
				blank	Sn	Ni		Ø	L 1		
		mm ² AWG		un-plated	Sn	Ni	Ø	mm	mm	mm	x 1000

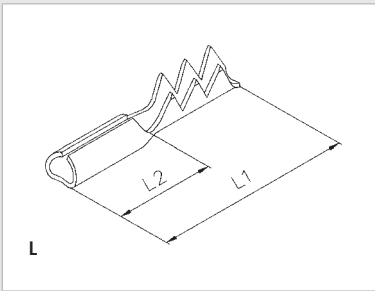

RSB 7897.001 R 1,23-0,25	0,05-0,25 28-24	CuZn	○	●		1,13	7,5	3,0	0,20	60
---------------------------------	--------------------	------	---	---	--	------	-----	-----	------	----

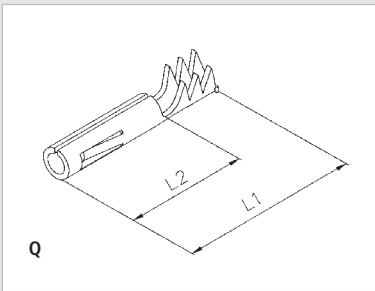

RBB 7860.001 R 1,5-0,5	0,3-0,5 22-20	CuZn	○	○	●	1,5	14,2	8,5	0,38	10
-------------------------------	------------------	------	---	---	---	-----	------	-----	------	----

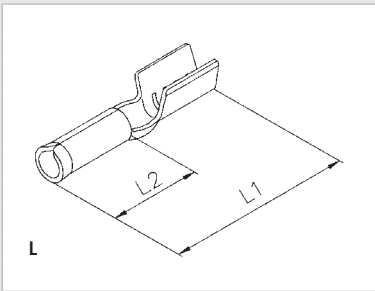

RSB 7854.001 R 1,9-1	0,5-1 20-18	X 5 CrNi	○			1,9	15,0	6,5	0,35	20
-----------------------------	----------------	----------	---	--	--	-----	------	-----	------	----

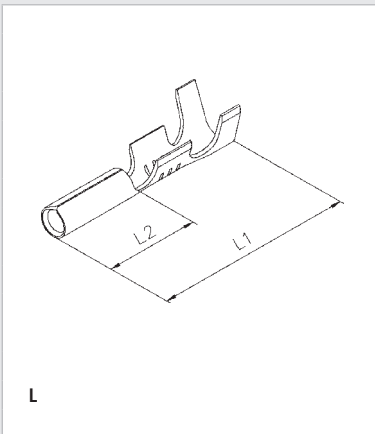

RBB 8000 R 1,7-0,75	0,25-0,75 24-20	CuZn	○	○		1,7	14,3	6,5	0,30	15
RBB 7786.005 R 2,25-0,75	0,34-1 22-18	CuZn	●	●	○	2,22	14,3	6,5	0,32	16
RBB 7786 R 2,3-0,75	0,34-1 22-18	CuZn	●	○	○	2,27	14,3	6,5	0,32	16
RBB 7786.001 R 2,3-0,75	0,34-1 22-18	CuZn	●	○	○	2,36	14,3	6,5	0,32	16
RBB 7957 R 3,9-1	0,75-1,5 18-16	CuZn	○	○		3,95	21,7	12,2	0,35	8

● Standard-Artikel / Standard parts ○ lieferbar auf Anfrage / available on request

Rundsteckhülsen Sockets

Bauform Q = Quertransport L = Längstransport	Artikel-Nummer	Leiterquerschnitt	Material	Veredlung			Innen Ø	Länge		Materialstärke	Verp.-Einh. Band
				blank	Sn	Ni		L 1 mm	L 2 mm		
				Supply condition Q = transverse transport / Side feed L = longitudinal transport / End feed	Part number	Wire size	Material			Finishing	
		mm ² AWG		un-plated	Sn	Ni	mm	mm	mm	x 1000	

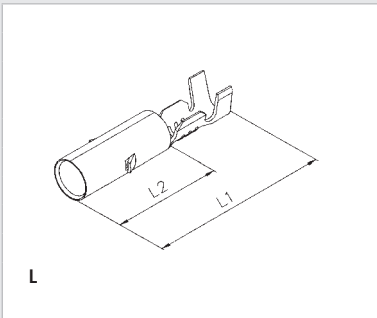

RBB 7957.002 R 3,9-1 Mit zwei Rasthaken With two retaining snaps	0,75-1,5 18-16	CuZn	●	○		3,95	21,7	12,2	0,35	8
---	-------------------	------	---	---	--	------	------	------	------	---

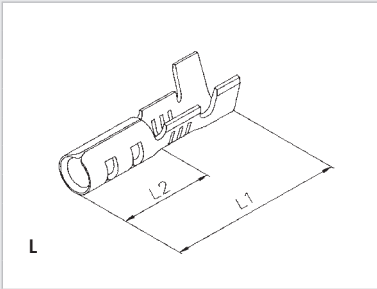

RBB 7786.004 R 2,3-0,75	0,34-1 22-18	CuZn	○	○	○	2,28	14,3	6,5	0,32	16
--------------------------------	-----------------	------	---	---	---	------	------	-----	------	----

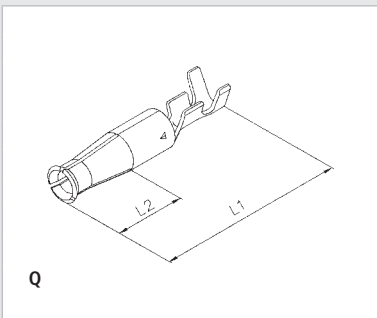

RBB 7994.002 F 2,3-0,75	0,22-0,5 24-22	CuSn		●		2,36	21,0	7,6	0,4	4,5
RBB 7994.003 F 2,3-0,75 Mit Bohrung With hole	0,22-0,5 24-22	CuSn	●			2,36	21,0	7,6	0,4	2

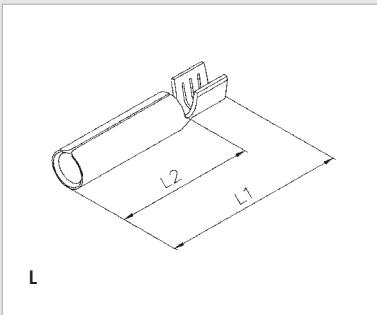

RBB 7869 R 2,3-0,75	0,25-0,75 22-20	CuZn	○	○	○	2,3	14,5	10,0	0,32	10
----------------------------	--------------------	------	---	---	---	-----	------	------	------	----

● Standard-Artikel / Standard parts ○ lieferbar auf Anfrage / available on request

Rundsteckhülsen Sockets

Bauform Q = Quertransport L = Längstransport	Artikel-Nummer	Freigabe s. Seiten 7/8	Leiterquer- schnitt	Material	Veredlung			Innen Ø	Länge		Material- stärke	Verp.-Einh. Band
					blank	Sn	Ni		Length			
					Finishing				Inside Ø	L 1 mm		
Supply condition Q = transverse transport / Side feed L = longitudinal transport / End feed	Part number	Approvals s. page 7/8	Wire size	Material	un- plated	Sn	Ni					
			mm ² AWG					mm	mm	mm		x 1000

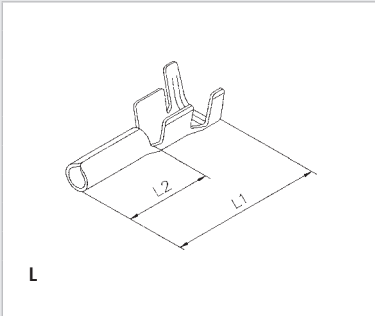

RBB 8110 R 1,85-1,5	1-1,5 18-16	CuZn	○	○		1,83	14,3	7,2	0,3	10
		Fe			○					
RBB 8110.001 R 1,93-1,5	0,5-1,5 20-16	CuZn	○	○		1,92	14,3	7,2	0,3	10
		Fe			○					

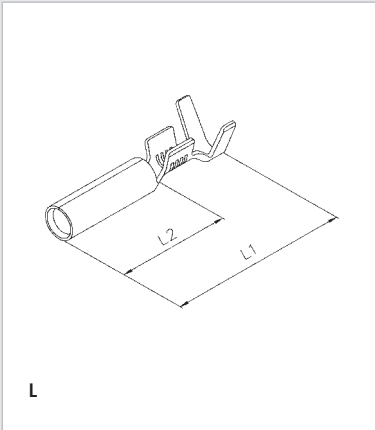

RBB 7995.003 R 1,2-1	●	0,5-1 20-18	X5CrNi	●		1,29	12,0	4,5	0,4	20
RBB 7995.004 R 1,2-1		0,5-1 20-18	X5CrNi	○		1,29	12,0	4,5	0,4	20
RBB 7995.005 R 1,4-1		0,5-1 20-18	X5CrNi	●		1,49	12,0	4,5	0,4	20
RSB 7836 R 3,8-1		0,5-1 20-18	CuZn	○	○	3,85	20,7	10,0	0,4	8
RSB 7836.003 R 3,8-1 Mit Verrastung With indentation		0,5-1 20-18	CuZn	○	○	3,85	20,7	10,0	0,4	8

● Standard-Artikel / Standard parts ○ lieferbar auf Anfrage / available on request

Rundsteckhülsen Sockets

Bauform Q = Quertransport L = Längstransport	Artikel-Nummer	Freigabe s. Seiten 7/8	Leiterquer- schnitt	Material	Veredlung			Innen Ø	Länge		Material- stärke	Verp.-Einh. Band
					blank	Sn	Ni		L 1 mm	L 2 mm		
					Finishing							
Supply condition Q = transverse transport / Side feed L = longitudinal transport / End feed	Part number	Approvals s. page 7/8	Wire size mm ² AWG	Material	un- plated	Sn	Ni	mm	mm	mm	Packing unit Chain form	x 1000

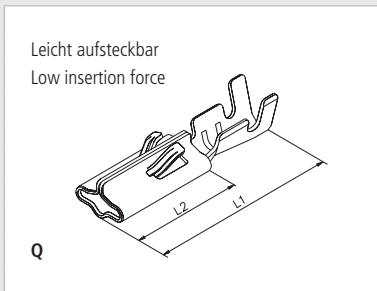

RFB 8185 R 1,3-0,75 Für Gehäusemontage For housings			0,35-0,75 22-18	CuSn	●	●		1,31	14,2	7,85	0,25	5,5
--	--	--	--------------------	------	---	---	--	------	------	------	------	-----

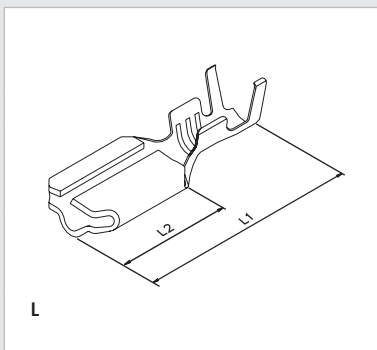

RFB 8121.115 R 1,5-1,5 Leicht aufsteckbar Low insertion force			0,5-1,5 20-16	Fe			●	1,38	14,3	6,3	0,35	7
RFB 8121.020 R 2-1,5	●		0,5-1,5 20-16	Fe			○	1,87	14,3	6,3	0,35	7
RFB 8121.022 R 2,25-1,5			0,5-1,5 20-16	Fe			○	2,08	14,3	6,3	0,35	7
RFB 8121.025 R 2,5-1,5	●		0,5-1,5 20-16	Fe			○	2,36	14,3	6,3	0,35	7

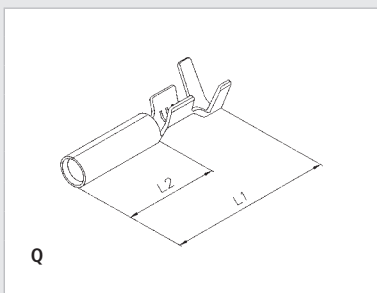

RBB 7975 R 2,3-0,75			0,34-0,75 22-20	CuZn			●	2,3	17,0	9,2	0,35	4,5
----------------------------	--	--	--------------------	------	--	--	---	-----	------	-----	------	-----

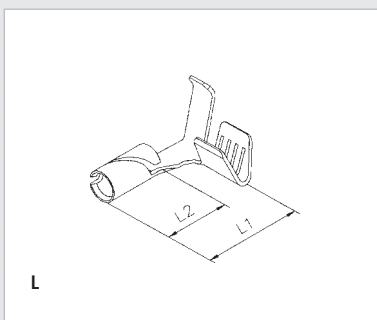

RBB 8069 R 1,9-1,5			0,75-1,5 18-16	Fe			●	1,9	9,0	5,0	0,32	5
RBB 8069.001 R 1,95-1,5			0,75-1,5 18-16	CuZn	○	○		1,95	9,0	5,0	0,32	5
RBB 8069.002 R 1,95-0,34			0,14-0,34 26-22	CuZn	○			1,95	9,0	5,0	0,30	5

● Standard-Artikel / Standard parts ○ lieferbar auf Anfrage / available on request

Rundstifte Circular pins

Bauform Q = Quertransport L = Längstransport Supply condition Q = transverse transport / Side feed L = longitudinal transport / End feed	Artikel-Nummer	Leiterquer- schnitt	Material	Veredlung			Außen Ø	Länge		Material- stärke	Verp.-Einh. Band
	Part number	Wire size	Material	Finishing		Outside Ø	Length		Material thickness	Packing unit Chain form	
		mm ² AWG		blank	Sn	Ni		L 1 mm	L 2 mm	mm	x 1000

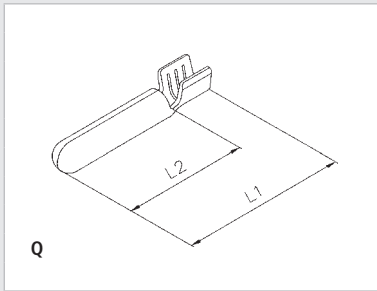

RTB 7861.001 P 2,4-0,75 Mit Spritzverschluß With rear end closed	0,5-0,75 20	CuZn				●	2,4	14,5	10,2	0,35	9
---	----------------	------	--	--	--	---	-----	------	------	------	---

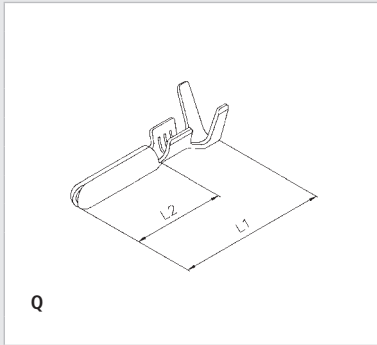

RTB 7861.002 P 2,4-0,75 Mit Spritzverschluß With rear end closed	0,5-0,75 20	CuZn				●	2,36	16,8	9,2	0,35	4
RTB 7861.003 P 2,4-0,75	0,5-0,75 20	CuZn				○	2,36	16,8	9,2	0,35	4

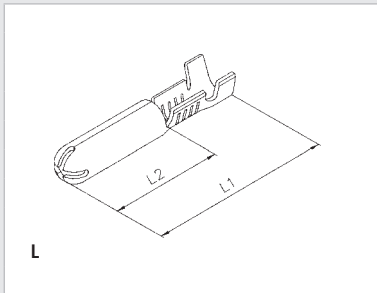

RSB 7835 P 4-1	0,5-1 20-18	CuZn	○	○			4,0	23,0	13,4	0,45	9
-----------------------	----------------	------	---	---	--	--	-----	------	------	------	---

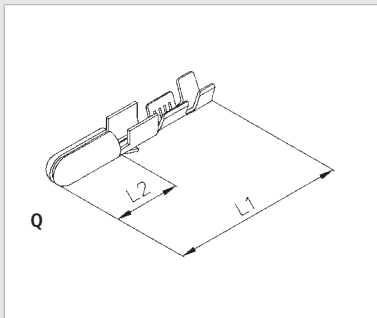

RTB 8037 R 4-1 Für Gehäusemontage For housings	0,38-1 20-18	CuNiZn	●				4,1	29,0	12,0	0,4	3,5
RTB 8037.001 R 4-1,5 Für Gehäusemontage For housings	0,5-1,5 20-16	CuNiZn	●				4,1	28,0	12,0	0,4	3,5
RTB 8037.002 R 4-1	0,38-1 20-18	CuNiZn	●				4,1	29,0	12,0	0,4	3,5

● Standard-Artikel / Standard parts ○ lieferbar auf Anfrage / available on request

Sonderanschlußteile Special connectors

Bauform Q = Quertransport L = Längstransport Supply condition Q = transverse transport / Side feed L = longitudinal transport / End feed	Artikel-Nummer	Leiterquer- schnitt	Material	Veredlung			Abmessungen			Material- stärke	Verp.-Einh. Band
	Part number	Wire size	Material	Finishing			Dimensions			Material thickness	Packing unit Chain form
				blank	Sn	Ni	B	L 1	L 2		
		mm ² AWG		un- plated	Sn	Ni	B mm	L 1 mm	L 2 mm	mm	

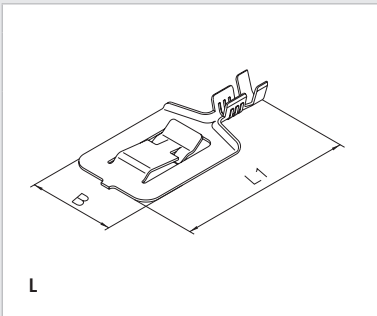

RVB 8239 V 0-1	0,5-1 20-18	CuZn		●			12,0	23,9		0,3	5

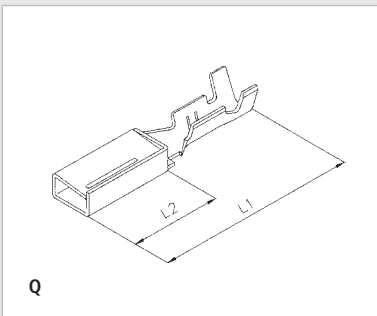

RFB 8007.001 V 2-1,5	0,34-1 22-18	CuZn	○	○			24,1	10,5		0,4	3,5

● Standard-Artikel / Standard parts ○ lieferbar auf Anfrage / available on request

Isolierkörper 2,8 - 4,8 - 6,3 mm

Gehäuse für Standard- und leicht aufsteckbare Flachsteckhülsen, gerade Ausführung

Insulation housings 2,8 - 4,8 - 6,3 mm

Housings for standard and low insertion force receptacles, straight version

Bauform	Artikel-Nummer	Material	Brennbarkeitsklasse			Farbe	Polzahl	Abmessungen mm				Verp.-Einh.	Zugehörige Artikel
Supply condition	Part number	Material	Flammability class			Colour	Positions	Dimensions mm				Packing unit	Fitting parts unit
			V 0	V 2	GWT 750 °C *			L	B	H	H 1	x 1000	

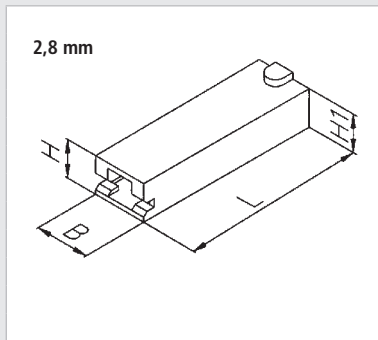

EH 657.100	PA 66	●			natur	1	19,8	5,2	4,0	4,6	50	RSB 7785 RSB 7990 RSB 8100
	PA 6/66	●			natur							
EH 657.100-G	PA 6		●	●								
EH 657.100	PA 66		●		schwarz	1	19,8	5,2	4,0	4,6	50	RSB 7785 RSB 7990 RSB 8100
	PA 46		●		black							
EH 657.100-G	PA 6/66	●										
	PA 6		●	●								

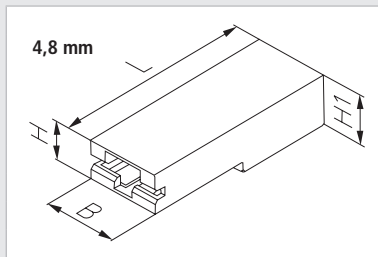

EH 650.100	PA 66		●		natur	1	20,0	8,0	5,4	6,0	25	RS / RSB 7603 RS / RSB 7604 RSB 8170 RS / RSB 7795 RSB 8091 RSB 8102
	PA 6/66	●			natur							
EH 650.100-G	PA 6		●	●								
EH 650.100	PA 46		●		schwarz	1	20,0	8,0	5,4	6,0	25	RS / RSB 7603 RS / RSB 7604 RSB 8170 RS / RSB 7795 RSB 8091 RSB 8102
					black							

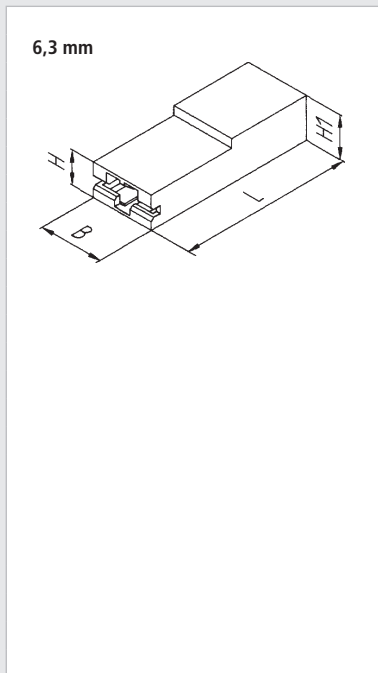

EH 649	PA 66		●		natur	1	25,0	9,5	4,8	6,2	15	RSB 8115 RS / RSB 8160 RS / RSB 7900 RS / RSB 7901 RS / RSB 8152 RSB 8260 RS / RSB 7839
	PA 6/66	●			natur							
EH 649-G	PA 6		●	●								
EH 649	PA 66		●		schwarz	1	25,0	9,5	4,8	6,2	15	RSB 8115 RS / RSB 8160 RS / RSB 7900 RS / RSB 7901 RS / RSB 8152 RSB 8260 RS / RSB 7839
	PA 6/66	●			black							
EH 649-G	PA 6		●	●								
EH 681	PA 66		●		natur	1	25,0	9,15	5,2	6,1	15	RSB 8137 RS / RSB 8238.158 RS / RSB 8238.258 RSB 8136 (3 mm² max.)
	PA 6/66	●			natur							
EH 681-G	PA 6		●	●								
EH 681	PA 66		●		schwarz	1	25,0	9,15	5,2	6,1	15	RSB 8137 RS / RSB 8238.158 RS / RSB 8238.258 RSB 8136 (3 mm² max.)
	PA 6/66	●			black							
EH 681-G	PA 6		●	●								

* glühdrahtbeständig, GWT 750 °C nach IEC 60335-1 – glow wire resistant, GWT 750 °C. acc. to IEC 60335-1

Andere Materialien und Farben auf Anfrage – Other materials / colors on request
Freigaben: siehe Seite 9 – Approvals: see page 9

Isolierkörper 4,8 - 6,3 mm

Gehäuse für Standard- und leicht aufsteckbare Flachsteckhülsen, Winkelausführung

Insulation housings 4,8 - 6,3 mm

Housings for standard and low insertion force receptacles, flag type version

Bauform	Artikel-Nummer	Material	Brennbarkeitsklasse			Farbe	Polzahl	Abmessungen mm				Verp.-Einh.	Zugehörige Artikel
Supply condition	Part number	Material	Flammability class			Colour	Positions	Dimensions mm				Packing unit	Fitting parts
			V 0	V 2	GWT 750 °C *			L	B	H	H 1	x 1000	

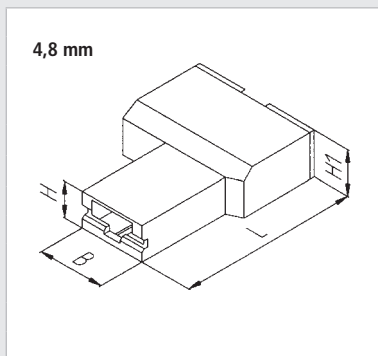

EH 683.002	PA 66		●			natur	1	14,2	7,5	4,4	5,2	20	RSB 7936.002 RSB 7936.003 RSB 8186.155 RSB 8186.158	
	PA 6/66	●				natur								
EH 683.002-G	PA 6			●	●									
EH 683.002	PA 66		●			schwarz black								
	PA 46		●											
	PA 6/66	●												
EH 683.002-G	PA 6			●	●									

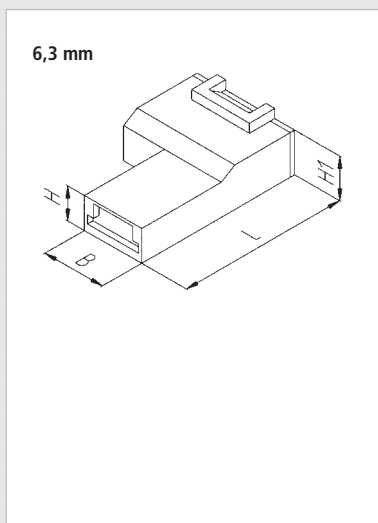

EH 678.100	PA 66		●			natur	1	16,2	9,6	4,8	5,7	15	RSB 7944 RSB 7909 RSB 7909.001 RSB 8240.158 RSB 8140 RSB 8140.158	
						natur								
EH 678.100-G	PA 6			●	●									
EH 678.100	PA 66		●			schwarz black								
	PA 46		●											
EH 679.200	PA 66		●			natur natural	1	18,8	9,6	4,8	6,2	15	RS / RSB 8138 RSB 8198.1208	
	PA 6/66	●												
EH 679.200-G	PA 6			●	●									
EH 679.200	PA 66		●			schwarz black								
	PA 6/66	●												

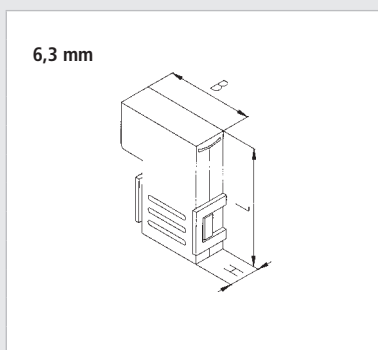

EH 658.100	PA 66		●			natur	1	18,0	13,4	5,2		12,5	RS / RSB 8138	
						natur								
EH 658.100-G	PA 6			●	●									
EH 658.100	PA 66		●			schwarz black								
EH 658.100-G	PA 6			●	●									

* glühdrahtbeständig, GWT 750 °C nach IEC 60335-1 – glow wire resistant, GWT 750 °C. acc. to IEC 60335-1

Andere Materialien und Farben auf Anfrage – Other materials / colors on request
Freigaben: siehe Seite 9 – Approvals: see page 9

Isolierkörper 4,8 mm

Gehäuse für verriegelbare Flachsteckhülsen

Insulation housings 4,8 mm

Housings for self locking receptacles

Bauform	Artikel-Nummer	Material	Brennbarkeitsklasse			Farbe	Polzahl	Abmessungen mm				Verp.-Einh.	Zugehörige Artikel
Supply condition	Part number	Material	Flammability class			Colour	Positions	Dimensions mm				Packing unit	Fitting parts
			V 0	V 2	GWT 750 °C *			L	B	H	H 1	x 1000	



EH 694	PA 66	●	●		natur	1	23,0	7,4	5,2		15	RSB 8168.055 RSB 8168.058 RSB 8168.155 RSB 8168.158
					natur							
EH 694-G	PA 6		●									
EH 694	PA 66	●	●		schwarz	1	23,0	7,4	5,2		15	
					black							
EH 694-G	PA 6		●	●								

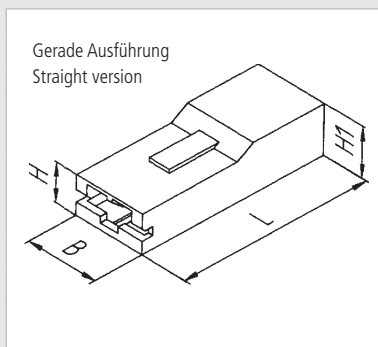

EH 680	PA 66		●		natur	1	23,0	7,2	4,5	6,0	25	RSB 8028 RSB 8029
	PA 6/66	●			natur							
EH 680-G	PA 6		●	●								
EH 680	PA 66		●		schwarz	1	23,0	7,2	4,5	6,0	25	
	PA 6/66	●			black							

* glühdrahtbeständig, GWT 750 °C nach IEC 60335-1 – glow wire resistant, GWT 750 °C. acc. to IEC 60335-1

Andere Materialien und Farben auf Anfrage – Other materials / colors on request
Freigaben: siehe Seite 9 – Approvals: see page 9

Isolierkörper 6,3 mm

Gehäuse für Flachsteckhülsen

Insulation housings 6,3 mm

Housings for receptacles

Bauform	Artikel-Nummer	Material	Brennbarkeitsklasse			Farbe	Polzahl	Abmessungen mm				Verp.-Einh.	Zugehörige Artikel
Supply condition	Part number	Material	Flammability class			Colour	Positions	Dimensions mm				Packing unit	Fitting parts
			V 0	V 2	GWT 750 °C *			L	B	H	H 1	x 1000	

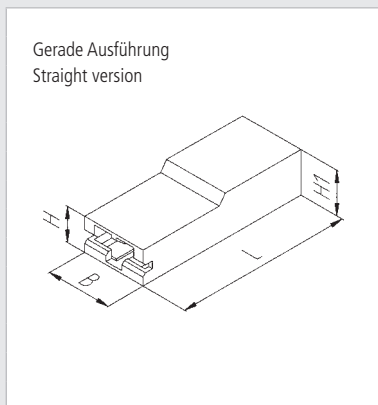

EH 695	PA 66	●	●		natur	1	25,0	9,3	5,0	6,3	10	RS / RSB 7960.XXX RS / RSB 7961.XXX RS / RSB 8056.XXX RS / RSB 8178.XXX
	PA 46		●		natural							
EH 695-G	PA 6		●	●								
EH 695	PA 66	●	●		schwarz							
	PA 46		●		black							
EH 695-G	PA 6		●	●								

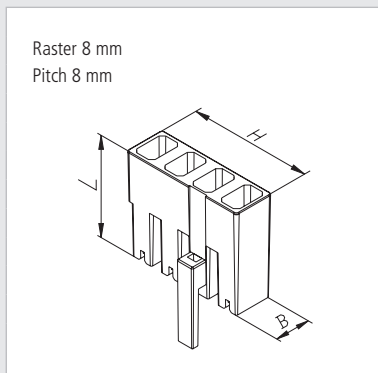

EH 700/4	PPS	●			schwarz	4	25,2	10,2	31	2	RSB 8180.1158 RSB 8220.1158
					black						

* glühdrahtbeständig, GWT 750 °C nach IEC 60335-1 – glow wire resistant, GWT 750 °C. acc. to IEC 60335-1

Andere Materialien und Farben auf Anfrage – Other materials / colors on request
Freigaben: siehe Seite 9 – Approvals: see page 9

Isolierkörper 6,3 mm

Mehrfachgehäuse für Flachsteckhülsen

Insulation housings 6,3 mm

Multi-way housings for receptacles

Bauform	Artikel-Nummer	Material	Brennbarkeitsklasse			Farbe	Polzahl	Abmessungen mm			Verp.-Einh.	Zugehörige Artikel
Supply condition	Part number	Material	Flammability class			Colour	Positions	Dimensions mm			Packing unit	Fitting parts
			V 0	V 2	GWT 750 °C *			L	B	H	x 1000	

Gerade Ausführung
Straight version

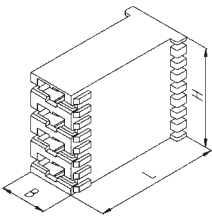

Codierung nach RAST 5
Codification according to
connector system RAST 5

EH 688-002-**	PA 66	●			natur	2	25,0	9,2	10	5	RSB 8178.XXXX
	PA 6		●	●	natural						
EH 688-003-**	PA 66	●			natur	3	25,0	9,2	15	3,5	RSB 8178.XXXX
	PA 6		●	●	natural						
EH 688-004-**	PA 66	●			natur	4	25,0	9,2	20	2,5	RSB 8178.XXXX
	PA 6		●	●	natural						
EH 688-005-**	PA 66	●			natur	5	25,0	9,2	25	1,5	RSB 8178.XXXX
	PA 6		●	●	natural						
EH 688-006-**	PA 66	●			natur	6	25,0	9,2	30	1	RSB 8178.XXXX
	PA 6		●	●	natural						
EH 688-007-**	PA 66	●			natur	7	25,0	9,2	35	0,5	RSB 8178.XXXX
	PA 6		●	●	natural						
EH 688-008-**	PA 66	●			natur	8	25,0	9,2	40	0,5	RSB 8178.XXXX
	PA 6		●	●	natural						

Gerade Ausführung
Straight version

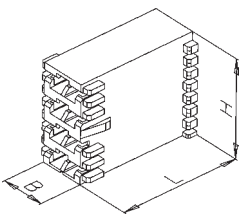

Codierung nach RAST 5
Codification according to
connector system RAST 5

EH 688.400-002-**	PA 66	●			natur	2	25,0	9,2	10	5	RSB 8178.XXXX
	PA 6		●	●	natural						
EH 688.400-003-**	PA 66	●			natur	3	25,0	9,2	15	3,5	RSB 8178.XXXX
	PA 6		●	●	natural						
EH 688.400-004-**	PA 66	●			natur	4	25,0	9,2	20	2,5	RSB 8178.XXXX
	PA 6		●	●	natural						
EH 688.400-005-**	PA 66	●			natur	5	25,0	9,2	25	1,5	RSB 8178.XXXX
	PA 6		●	●	natural						
EH 688.400-006-**	PA 66	●			natur	6	25,0	9,2	30	1	RSB 8178.XXXX
	PA 6		●	●	natural						
EH 688.400-007-**	PA 66	●			natur	7	25,0	9,2	35	0,5	RSB 8178.XXXX
	PA 6		●	●	natural						
EH 688.400-008-**	PA 66	●			natur	8	25,0	9,2	40	0,5	RSB 8178.XXXX
	PA 6		●	●	natural						

* glühdrahtbeständig, GWT 750 °C nach IEC 60335-1 – glow wire resistant, GWT 750 °C. acc. to IEC 60335-1

** Abartennummer gemäß RAST 5 Codiertabelle – Version number as per the RAST 5 polarizing chart

Andere Materialien und Farben auf Anfrage – Other materials / colors on request
Freigaben: siehe Seite 9 – Approvals: see page 9

Isolierkörper 6,3 mm

Mehrfachgehäuse für Flachsteckhülsen

Insulation housings 6,3 mm

Multi-way housings for receptacles

Bauform	Artikel-Nummer	Material	Brennbarkeitsklasse			Farbe	Polzahl	Abmessungen mm			Verp.-Einh.	Zugehörige Artikel
Supply condition	Part number	Material	Flammability class			Colour	Positions	Dimensions mm			Packing unit	Fitting parts
			V 0	V 2	GWT 750 °C *			L	B	H	x 1000	

Raster 5 mm
Pitch 5 mm

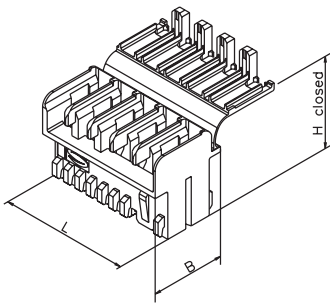

Codierung nach RAST 5
Codification according to
connector system RAST 5

EH 699-002-**	PA 6		●	●	natur natural	2	10	14,5	18	2	RSB 8240.1158
EH 699-003-**	PA 6		●	●	natur natural	3	15	14,5	18	2	RSB 8240.1158
EH 699-004-**	PA 6		●	●	natur natural	4	20	14,5	18	1	RSB 8240.1158
EH 699-005-**	PA 6		●	●	natur natural	5	25	14,5	18	1	RSB 8240.1158
EH 699-006-**	PA 6		●	●	natur natural	6	30	14,5	18	0,5	RSB 8240.1158
EH 699-007-**	PA 6		●	●	natur natural	7	35	14,5	18	0,5	RSB 8240.1158
EH 699-008-**	PA 6		●	●	natur natural	8	40	14,5	18	0,5	RSB 8240.1158

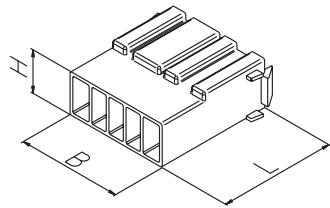

Codierung nach RAST 5
Codification according to
connector system RAST 5

EH 798-003-025-960-G	PA 6		●	●	natur natural	3	30	17	11	15	3 x RMB 7831.010
EH 798-003-025-960	PA 6/66	●									
EH 798-005-020-960	PA 6/66	●			natur natural	5	30	27	11	15	5 x RMB 7831.010

* glühdrahtbeständig, GWT 750 °C nach IEC 60335-1 – glow wire resistant, GWT 750 °C. acc. to IEC 60335-1

** Abartennummer gemäß RAST 5 Codetabelle – Version number as per the RAST 5 polarizing chart

Andere Materialien und Farben auf Anfrage – Other materials / colors on request
Freigaben: siehe Seite 9 – Approvals: see page 9

Isolierkörper 2,8 mm

Gehäuse für Flachsteckhülsen und Flachstecker

Insulation housings 2,8 mm

Housings for receptacles and tabs

Bauform	Artikel-Nummer	Material	Brennbarkeitsklasse			Farbe	Polzahl	Abmessungen mm				Verp.-Einh.	Zugehörige Artikel
Supply condition	Part number	Material	Flammability class			Colour	Positions	Dimensions mm				Packing unit	Fitting parts
			V 0	V 2	GWT 750 °C *			L	B	H	H 1	x 1000	

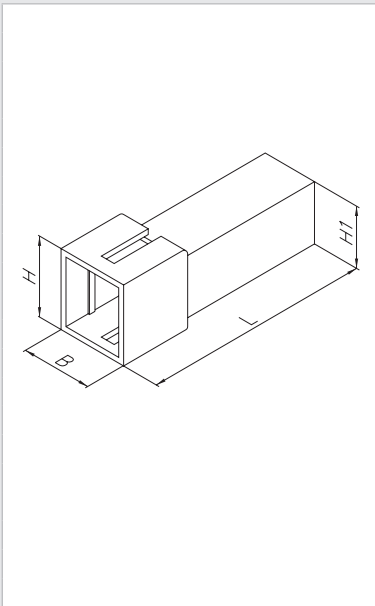

EH 701	PA 66		●			natur natural	1	25,8	8,5	8,5	6,6	15	RM/RMB 8039.XXX
EH 701-G	PA 6		●	●									

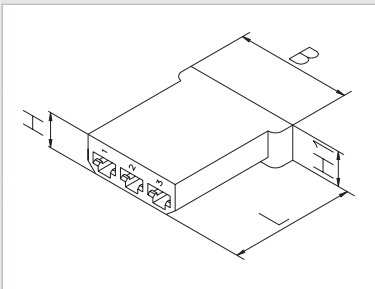

EH 728	PA 66		●			natur natural	3	18,0	19,2	5,0		15	3 x RSB 8280.XXX
---------------	-------	--	---	--	--	------------------	---	------	------	-----	--	----	------------------

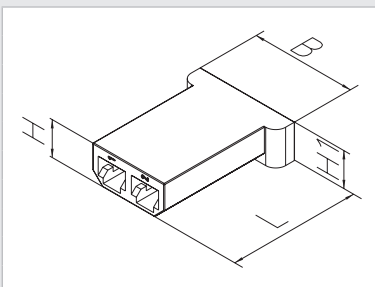

EH 727.001	PA 6		●	●		natur natural	2	18,0	14,2	5,0		15	2 x RSB 8280.XXX
EH 727.002	PA 6		●	●		schwarz black							

* glühdrahtbeständig, GWT 750 °C nach IEC 60335-1 – glow wire resistant, GWT 750 °C. acc. to IEC 60335-1

Andere Materialien und Farben auf Anfrage – Other materials / colors on request
Freigaben: siehe Seite 9 – Approvals: see page 9

Isolierkörper 6,3 mm

Gehäuse für Flachsteckhülsen und Flachstecker

Insulation housings 6,3 mm

Housings for receptacles and tabs

Bauform	Artikel-Nummer	Material	Brennbarkeitsklasse			Farbe	Polzahl	Abmessungen mm				Verp.-Einh.	Zugehörige Artikel
Supply condition	Part number	Material	Flammability class			Colour	Positions	Dimensions mm				Packing unit	Fitting parts
			V 0	V 2	GWT 750 °C *			L	B	H	H 1	x 1000	

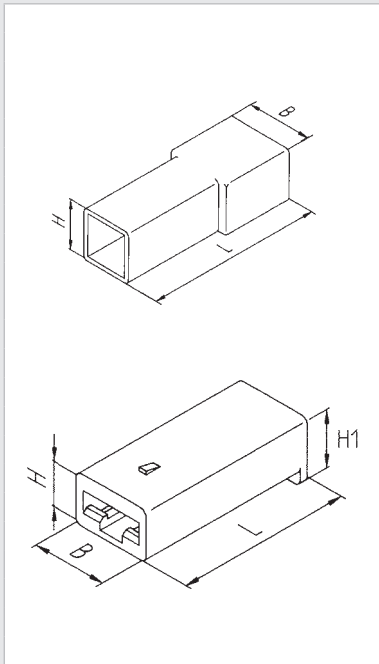

VV 2023.100	PA 66	●	●		natur	1	31,6	12,5	9,3		6,5	1 x RM 7831.010 1 x RMB 7831.010 1 x RM 7833.010 1 x RMB 7833.010	
	PA 6/66	●			natur								
VV 2023.100-G	PA 6		●	●									
VV 2023.100	PA 66		●		schwarz								
					black								
VV 2023.200	PA 66		●	●	natur	1	23,0	9,9	6,5	8,1	13	1 x RS / RSB 7858 1 x RS / RSB 7916	
					natur								
VV 2023.200-G	PA 6		●										
VV 2023.200	PA 66		●	●	schwarz								
					black								

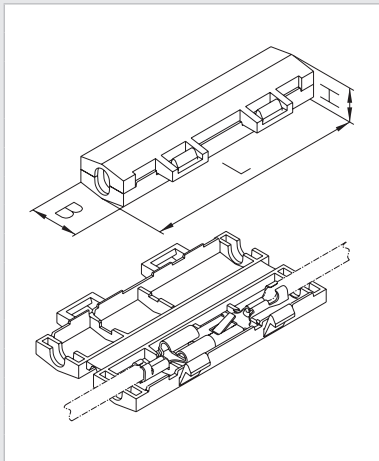

EH 718.100	PA 6		●		natur	1	51,25	11,5	8		2,5	RSB 7900 RSB 7960.020 RSB 8160.158 RSB 8160.258 + RM/RMB 7831.010 RM/RMB 7840 RSB 8028 RSB 8170.158 RS/RSB 7604.258 + RMB 8165.108 Weitere Artikel auf Anfrage Other parts on request	
					natur								

* glühdrahtbeständig, GWT 750 °C nach IEC 60335-1 – glow wire resistant, GWT 750 °C. acc. to IEC 60335-1

Andere Materialien und Farben auf Anfrage – Other materials / colors on request
Freigaben: siehe Seite 9 – Approvals: see page 9

Isolierkörper 6,3 mm

Mehrfachgehäuse für Flachsteckhülsen und Flachstecker

Insulation housings 6,3 mm

Multi-way housings for receptacles and tabs

Bauform	Artikel-Nummer	Material	Brennbarkeitsklasse			Farbe	Polzahl	Abmessungen mm				Verp.-Einh.	Zugehörige Artikel
Supply condition	Part number	Material	Flammability class			Colour	Positions	Dimensions mm				Packing unit	Fitting parts
			V 0	V 2	GWT 750 °C *			L	B	H	H 1	x 1000	

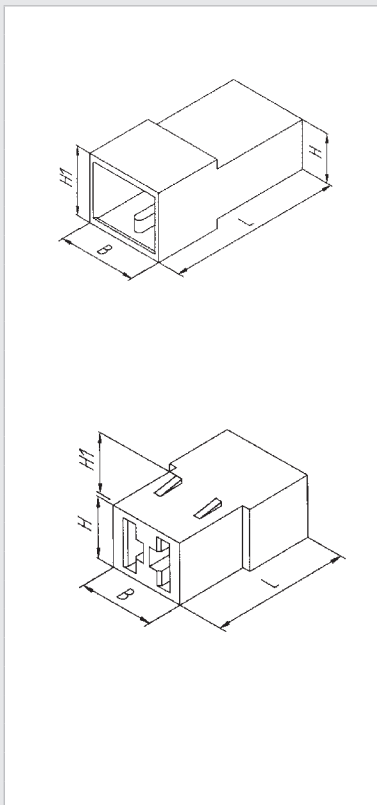

VV 2025.100	PA 66		●			natur natural	2	31,5	15,0	9,3	13,0	4	2 x RM 7831.010 2 x RMB 7831.010 2 x RM 7833.010 2 x RMB 7833.010
VV 2025.100-G	PA 6		●	●									
VV 2025.100	PA 46		●										
VV 2025.100	PA 66		●			schwarz black							
VV 2025.200	PA 66		●			natur natural	2	23,0	12,5	10,0	11,4	6,5	2 x RS / RSB 7858 2 x RS / RSB 7916
VV 2025.200-G	PA 6		●	●									
VV 2025.200	PA 66		●			schwarz black							

* glühdrahtbeständig, GWT 750 °C nach IEC 60335-1 – glow wire resistant, GWT 750 °C. acc. to IEC 60335-1

Andere Materialien und Farben auf Anfrage – Other materials / colors on request
Freigaben: siehe Seite 9 – Approvals: see page 9

Isolierkörper 6,3 mm

Mehrfachgehäuse für Flachsteckhülsen und Flachstecker

Insulation housings 6,3 mm

Multi-way housings for receptacles and tabs

Bauform	Artikel-Nummer	Material	Brennbarkeitsklasse			Farbe	Polzahl	Abmessungen mm				Verp.-Einh.	Zugehörige Artikel
Supply condition	Part number	Material	Flammability class			Colour	Positions	Dimensions mm				Packing unit	Fitting parts
			V 0	V 2	GWT 750 °C *			L	B	H	H 1	x 1000	

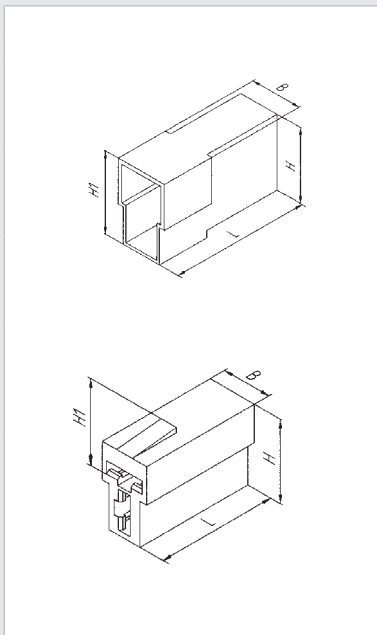

VV 2041.100	PA 66	●			natur natural	2	31,6	12,5	18,0	20,0	3,5	2 x RM 7831.010 2 x RMB 7831.010 2 x RM 7833.010 2 x RMB 7833.010
	PA 6	●	●									
VV 2041.200	PA 66	●			natur natural	2	23,0	10,0	16,6	18,0	7	2 x RS / RSB 7858 2 x RS / RSB 7916
	PA 6	●	●									

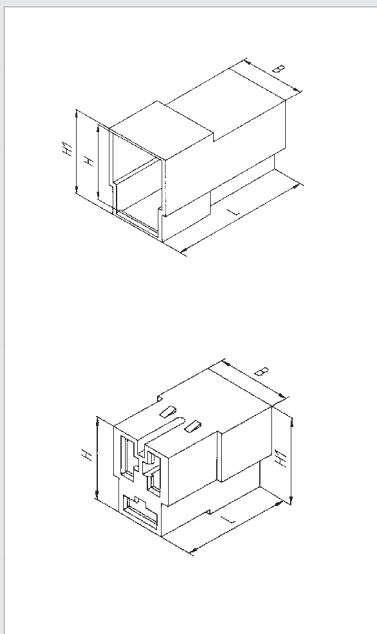

VV 2072.100	PA 66	●			schwarz black	3	31,7	15,2	17,7	19,8	2,5	3 x RM 7831.010 3 x RMB 7831.010 3 x RM 7833.010 3 x RMB 7833.010
	PA 66	●			natur natural							
VV 2072.100-G	PA 6	●	●									
VV 2072.200	PA 66	●			natur natural	3	23,0	15,2	16,6	17,8	4	3 x RS / RSB 7858 3 x RS / RSB 7916
	PA 6	●	●									
VV 2072.200-G	PA 66	●			schwarz black							

* glühdrahtbeständig, GWT 750 °C nach IEC 60335-1 – glow wire resistant, GWT 750 °C. acc. to IEC 60335-1

Andere Materialien und Farben auf Anfrage – Other materials / colors on request
Freigaben: siehe Seite 9 – Approvals: see page 9

Isolierkörper 6,3 mm

Mehrfachgehäuse für Flachsteckhülsen und Flachstecker

Insulation housings 6,3 mm

Multi-way housings for receptacles and tabs

Bauform	Artikel-Nummer	Material	Brennbarkeitsklasse			Farbe	Polzahl	Abmessungen mm				Verp.-Einh.	Zugehörige Artikel
Supply condition	Part number	Material	Flammability class			Colour	Positions	Dimensions mm				Packing unit	Fitting parts
			V 0	V 2	GWT 750 °C *			L	B	H	H 1	x 1000	

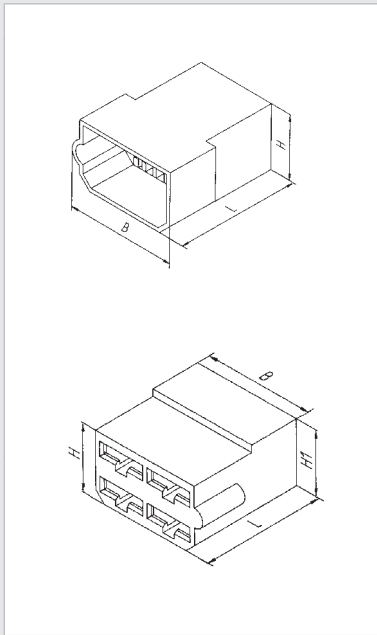

VV 2026.100	PA 66	●			natur natural	4	32,3	28,5	16,4		1,75	4 x RM 7831.010 4 x RMB 7831.010 4 x RM 7833.010 4 x RMB 7833.010
VV 2026.100-G	PA 6	●	●									
VV 2026.100	PA 66	●			schwarz black							
VV 2026.200	PA 66	●			natur natural	4	24,0	23,0	13,8	15,5	2,5	4 x RS / RSB 7858 4 x RS / RSB 7916
VV 2026.200-G	PA 6	●	●									
VV 2026.200	PA 66	●			schwarz black							

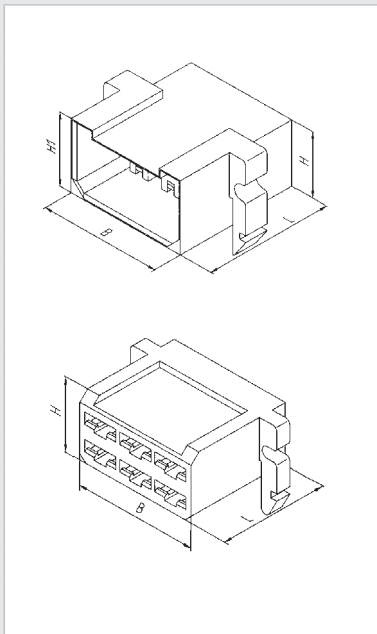

VV 2028.100	PA 66	●			natur natural	6	32,0	31,4	16,1	18,0	1	6 x RM 7831.010 6 x RMB 7831.010 6 x RM 7833.010 6 x RMB 7833.010
VV 2028.100-G	PA 6	●	●									
VV 2028.100	PA 66	●			schwarz black							
VV 2028.300	PA 66	●			natur natural	6	24,0	28,3	15,2		2	6 x RS / RSB 7858 6 x RS / RSB 7916

* glühdrahtbeständig, GWT 750 °C nach IEC 60335-1 – glow wire resistant, GWT 750 °C. acc. to IEC 60335-1

Andere Materialien und Farben auf Anfrage – Other materials / colors on request
Freigaben: siehe Seite 9 – Approvals: see page 9

Isolierkörper 6,3 mm

Mehrfachgehäuse für Flachsteckhülsen und Flachstecker

Insulation housings 6,3 mm

Multi-way housings for receptacles and tabs

Bauform	Artikel-Nummer	Material	Brennbarkeitsklasse			Farbe	Polzahl	Abmessungen mm				Verp.-Einh.	Zugehörige Artikel
Supply condition	Part number	Material	Flammability class			Colour	Positions	Dimensions mm				Packing unit	Fitting parts
			V 0	V 2	GWT 750 °C *			L	B	H	H 1	x 1000	

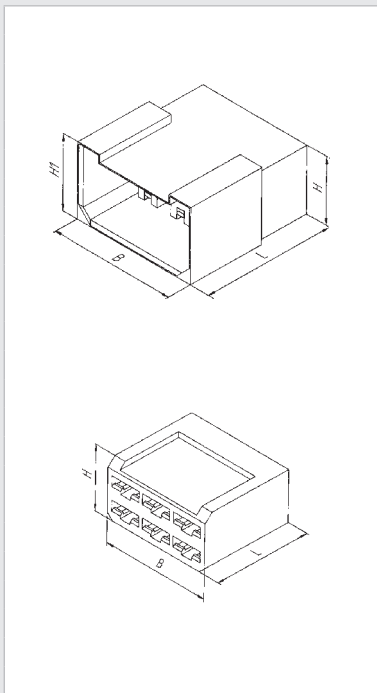

VV 2028.110	PA 66	●			natur natural	6	32,0	31,5	16,0	18,5	1,25	6 x RM 7831.010 6 x RMB 7831.010 6 x RM 7833.010 6 x RMB 7833.010
VV 2028.110-G	PA 6	●	●									
VV 2028.110	PA 66	●			schwarz black							
VV 2028.200	PA 66	●			natur natural	6	24,2	28,6	15,5		2,5	6 x RS / RSB 7858 6 x RS / RSB 7916
VV 2028.200-G	PA 6	●	●									
VV 2028.200	PA 66	●			schwarz black							

* glühdrahtbeständig, GWT 750 °C nach IEC 60335-1 – glow wire resistant, GWT 750 °C. acc. to IEC 60335-1

Andere Materialien und Farben auf Anfrage – Other materials / colors on request
Freigaben: siehe Seite 9 – Approvals: see page 9

Isolierkörper 6,3 mm

Mehrfachgehäuse für Flachsteckhülsen und Flachstecker

Insulation housings 6,3 mm

Multi-way housings for receptacles and tabs

Bauform	Artikel-Nummer	Material	Brennbarkeitsklasse			Farbe	Polzahl	Abmessungen mm				Verp.-Einh.	Zugehörige Artikel
Supply condition	Part number	Material	Flammability class			Colour	Positions	Dimensions mm				Packing unit	Fitting parts
			V 0	V 2	GWT 750 °C *			L	B	H	H 1	x 1000	

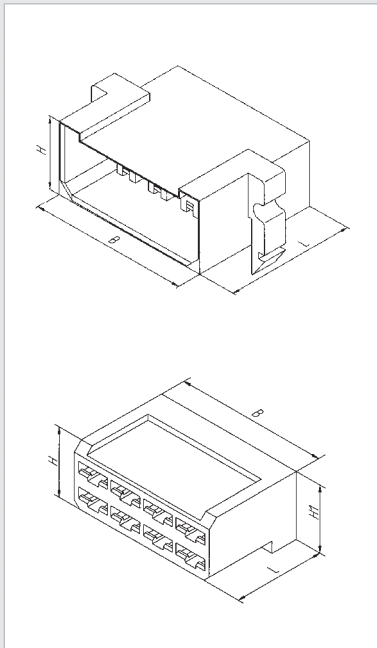

VV 2029.100	PA 66	●			natur natural	8	32,0	40,7	18,1		0,75	8 x RM 7831.010 8 x RMB 7831.010 8 x RM 7833.010 8 x RMB 7833.010	
VV 2029.100	PA 66	●			schwarz black								
VV 2029.200	PA 66	●			natur natural	8	24,2	37,6	13,7	16,5	1,5	8 x RS / RSB 7858 8 x RS / RSB 7916	
VV 2029.200	PA 66	●			schwarz black								

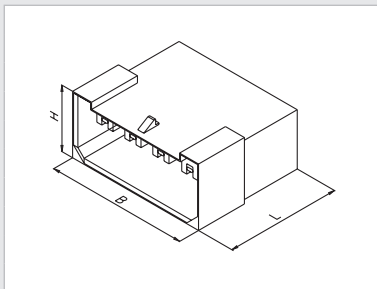

VV 2029	PA 66	●			natur natural	8	32,0	40,5	18,1		1	8 x RM 7831.010 8 x RMB 7831.010 8 x RM 7833.010 8 x RMB 7833.010

* glühdrahtbeständig, GWT 750 °C nach IEC 60335-1 – glow wire resistant, GWT 750 °C. acc. to IEC 60335-1

Andere Materialien und Farben auf Anfrage – Other materials / colors on request
Freigaben: siehe Seite 9 – Approvals: see page 9

STOCKOMAT CRIMP *professional line*

Halbautomaten für die Verarbeitung von Crimpkontakten in Bandform



STOCKOMAT CRIMP WT 45-1



STOCKOMAT CRIMP WT 45-3

Merkmale

- Einfache, übersichtliche Handhabung
- Automatische Artikelzuführung
- Einsatz von Schnellwechselwerkzeugen für Längs- und Quertransport mit mechanischem Artikelvorschub
- Integrierte Abisoliervorrichtung (WT 45-3)
- Option: Crimpkraftüberwachungssystem
- Zertifizierung nach CE

Technische Daten	WT 45-1	WT 45-3	WT 46-1	WT 47-1
Maschinenhub	40 mm	40 mm	40 mm	40 mm
Pressen-Nennkraft	20 kN	20 kN	25 kN	50 kN
Betriebsspannung	240 V	240 V	240 V	240 V
Stromart	50/60 Hz	50/60 Hz	50/60 Hz	50/60 Hz
Anschlußwert	0,75 kW	0,75 kW	1,5 kW	2 kW
Luftdruck	6 bar	6 bar	6 bar	6 bar
Gewicht	85 kg	95 kg	95 kg	140 kg
Maschinenaktzeit	0,3 sec.	< 1 sec.	0,3 sec.	0,3 sec.
Leiterquerschnitt	< 4 mm ² (> 4 mm ² auf Anfrage)	0,25 - 2,5 mm ²	< 6 mm ² (> 6 mm ² auf Anfrage)	16 mm ² max. bei max. 1,2 mm Materialdicke
Abisolierlänge		2 - 12 mm		
Abmessungen B x T x H	300 x 400 x 760 mm	520 x 400 x 760 mm	330 x 480 x 860 mm	330 x 480 x 860 mm

STOCKOMAT CRIMP *professional line*

Semi-automatic terminating machines for crimp contacts in bandolier form



STOCKOMAT CRIMP WT 45-1

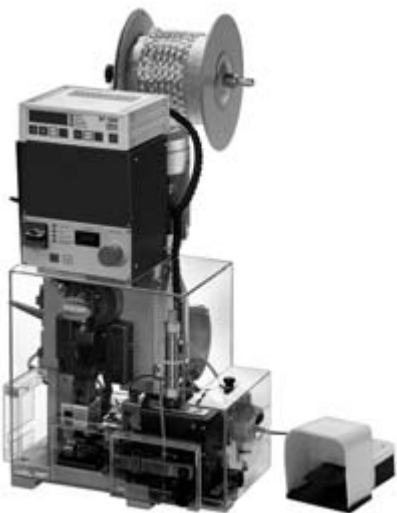

STOCKOMAT CRIMP WT 45-3

Main Features

- Easy and clear to operate
- Automated product feed
- Suitable for quick-change tools for longitudinal and transverse transport with mechanical feed system
- Integrated stripper device (WT 45-3)
- Optional: crimping force monitoring system
- Certification to CE

Technical Data	WT 45-1	WT 45-3	WT 46-1	WT 47-1
Machine stroke	40 mm	40 mm	40 mm	40 mm
Pressure rating	20 KN	20 KN	25 KN	50 KN
Operating voltage	240 V	240 V	240 V	240 V
Current	50/60 Hz	50/60 Hz	50/60 Hz	50/60 Hz
Connected load	0,75 kW	0,75 kW	1,5 kW	2 kW
Pneumatics	6 bar	6 bar	6 bar	6 bar
Weight	85 kg	95 kg	95 kg	140 kg
Cycle time	0,3 sec.	< 1 sec.	0,3 sec.	0,3 sec.
Wire size	< 4 mm ² (> 4 mm ² on request)	0,25 - 2,5 mm ²	< 6 mm ² (> 6 mm ² on request)	16 mm ² max. Thickness 1.2 mm max.
Stripping length		2 - 12 mm		
Dimensions W x D x H	300 x 400 x 760 mm	520 x 400 x 760 mm	330 x 480 x 860 mm	330 x 480 x 860 mm

STOCKOMAT Crimp *professional line*

Werkzeuge

Tools

Schnellwechselwerkzeuge für Längstransport Quick-change tools for longitudinal transport

Schnellwechselwerkzeug für Artikel, die hintereinander angebunden sind.
Der Vorschub erfolgt mechanisch.
Diese Variante ist geeignet für die Verarbeitung von Artikeln bis max. 31 mm Transportlänge.
Option: Werkzeug mit pneumatischem Vorschub.

Quick-change tool for products which are mounted in line.
Mechanical feed system.
This version is suitable for terminating products with up to 31 mm feed length.
On option, we can provide a pneumatic feed system.

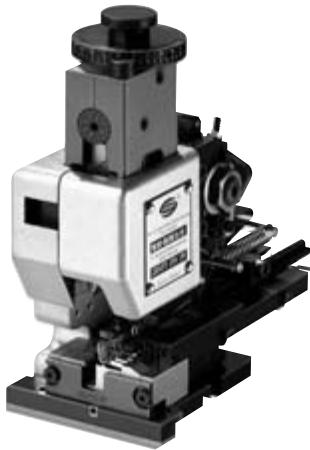

Schnellwechselwerkzeuge für Quertransport Quick-change tools for transverse transport

Schnellwechselwerkzeug für Artikel, die quer an den Transportstreifen angebunden sind.
Der Vorschub erfolgt mechanisch.
Diese Variante ist geeignet für die Verarbeitung von Artikeln bis max. 25 mm Transportlänge.
Option: Werkzeug mit pneumatischem Vorschub.

Quick-change tool for products which are mounted side by side on the carrier strip.
Mechanical feed system.
This version is suitable for terminating products with up to 25 mm feed length.
On option, we can provide a pneumatic feed system.











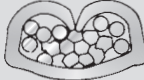

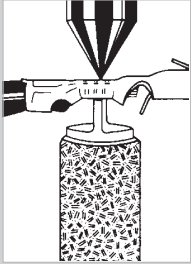

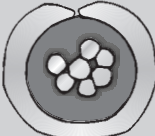

Crimp-Qualitäts-Übersicht

Crimp quality chart

UL-Freigaben und eine einwandfreie Verdrimpung unserer Produkte sind nur dann gewährleistet, wenn die Verarbeitung auf STOCKO-Werkzeugen erfolgt.

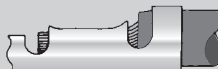
UL approvals and correct crimping only ensured on products crimped with STOCKO applicators.

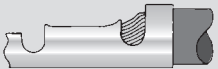
	Richtig Correct	Falsch Incorrect	Falsch Incorrect	Crimphöhen-Messung* Measuring the crimp height*
Drahtcrimp Conductor crimp		 Crimphöhe zu hoch Volumen zu klein Crimp height too high Volume too small	 Überpressung! Volumen zu klein Stempelverschleiß Over-crimped! Volume too small Worn punch	 Drahtcrimp Wire crimp
Isolationscrimp Insulation crimp		 Volumen zu klein Volume too small	 Crimphöhe zu niedrig Volumen zu klein Crimp height too low Volume too small	
		 Volumen zu groß Volume too large	 Volumen zu klein Volume too small	 Isolationscrimp Insulation crimp
		 Volumen zu groß Volume too large	 Crimphöhe zu hoch Volumen zu klein Crimp height too high Volume too small	
Längeneinstellung Length adjustment		 Zu weit eingelegt Isolation im Drahtcrimp Cable inserted too deep Insulation in wire crimping bucket	 Nicht weit genug eingelegt Isolation nicht sichtbar Cable inserted not deep enough Insulation invisible	

Leiterauszugskraft:

Eine Kontrollmessung ohne Isolationskralle wird mit dem entsprechenden Gerät vorgenommen. Die Meßwerte sind mit den Angaben des Crimp-Datenblattes zu vergleichen.

Tensile strength (crimped conductor)

Tension of conductor crimp to be measured with a suitable instrument (without insulation crimp). The values obtained are to be compared with the specification of the data sheet.



*Crimphöhen-Messung

*Measuring the crimp height

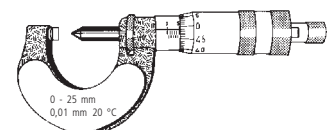

»Allgemeine Sicherheitshinweise für Steckverbinder und Kontakte«

General safety information for connectors and contacts

Die Anwendungsparameter von Steckverbindern und Kontakten werden in Datenblättern und Katalogen definiert. STOCKO-Produkte sind darauf ausgelegt, innerhalb der vorgegebenen Spezifikationen betrieben zu werden. Jede Anwendung unserer Produkte außerhalb der in den Spezifikationen zugelassenen Grenzwerte kann gefährlich sein und die Nichtbeachtung der folgenden Hinweise kann deshalb schwerwiegende Folgen haben.

Eigenschaften der eingesetzten Materialien

Verwendet werden flammgeschützte thermoplastische Isolationswerkstoffe, Kontaktmaterialien auf Kupfer- oder Stahlbasis und Oberflächenbeschichtungen aus Zinn, Nickel oder Gold. In Einzelfällen, z.B. bei kundenspezifischen Produkten, können auch andere hier nicht aufgeführte Materialien zum Einsatz kommen. Die für die jeweiligen Produkte eingesetzten Materialien können je nach Anwendung variieren und auf die spezifischen Anforderungen abgestimmt sein.

Wenn die Steckverbinder und Kontakte in den in Spezifikationen und Datenblättern angegebenen Grenzen betrieben werden, bleiben die technischen Eigenschaften langfristig stabil. Werden jedoch durch besondere Betriebsbedingungen oder im Störfall die Grenzwerte überschritten oder die Steckverbinder und Kontakte z.B. extremen Umweltbedingungen ausgesetzt, können sich die Eigenschaften der eingesetzten Materialien verändern.

Die fehlerhafte Kontaktierung eines Leiters mit ungeeigneten Werkzeugen, deformierte oder gebrochene Kontakte, Überschreitung der zulässigen Strombelastung, unvollständige Steckung der Stecker und Kontakte oder schlecht gelötete Kontakte können zu einer Überschreitung der zulässigen Grenztemperatur einer Steckverbindung oder eines Kontaktes führen. In diesen Fällen kann das Isolationsmaterial in seinen elektrischen Eigenschaften beeinträchtigt werden und bei Berührung die Gefahr eines elektrischen Schlags bestehen.

Hält eine Überhitzung über die spezifizierte Grenztemperatur längere Zeit an, baut sich die Kontaktkraft der Federkontakte ab und Oxidschichten bilden sich auf Kontakten und Drähten. Der Kontaktwiderstand steigt dadurch an, weitere Temperaturerhöhungen sind die Folge und das Isolationsmaterial kann bis hin zur Verkohlung geschädigt werden. Auf Grund dieser thermischen Schädigung des Isolationsmaterials können sich Kriech- oder Leckströme bilden. Dabei können Flammen entstehen, die brennbares Material in der Umgebung entzünden und unter Umständen Brände auslösen.

Eine sorgfältige Behandlung von Steckverbindern und Kontakten auf dem Transport, in der Verarbeitung und in der Anwendung ist deshalb unbedingt notwendig. Beschädigungen können Gefährdungen nach sich ziehen. Vor dem Einbau sollten die Produkte deshalb geprüft und im Falle von fehlerhafter Verarbeitung oder vorhandener Beschädigung nicht weiterverwandt werden.

The suitability parameters for connectors and contacts are defined in the data sheets and catalogues. STOCKO products are designed to meet these specifications. To employ our products outside the specified parameters can be dangerous and neglecting the following information can have serious consequences.

Properties of the materials employed

Materials used are thermoplastic insulation materials, contact materials based on copper or steel, and tin, nickel or gold surface finishes. Under special circumstances, like products to customers' specification, also other materials than those mentioned may be used. The selected materials for individual products can vary, being tuned according to application.

Provided connectors and contacts are used within the specified limits of the data sheets, the technical properties will remain stable over a long period of time. If, however, these limits are exceeded due to special circumstances or faulty production or due to exposure to extreme environmental conditions, the properties of the materials may change.

The faulty termination of contact and conductor with unsuitable tools, deformed or broken contacts, excessive current load, unfinished connections of connectors and contacts or badly soldered contacts can lead to exceeding the permissible temperature range of the connector or contact. In such event the insulating material may be impaired and, if touched, the danger of electric shock may exist.

Over-heating due to exceeding the specified temperature limits over a longer period will result in a reduction of the contact force of contacts and an oxide layer will build up on contacts and conductors. The contact resistance will increase and further temperature rises will result in damaging the insulating material with the danger of charring. Creeping or leakage currents can be formed owing to the thermal damaged insulation. This may cause combustion that ignites the surrounding inflammable material and may even start a fire.

A careful handling of connectors and contacts in all stages of transport, manufacture and application is absolutely important. Damaged components can create dangers. The products, therefore, should be examined before assembly and must not be further processed, if badly terminated or defective.

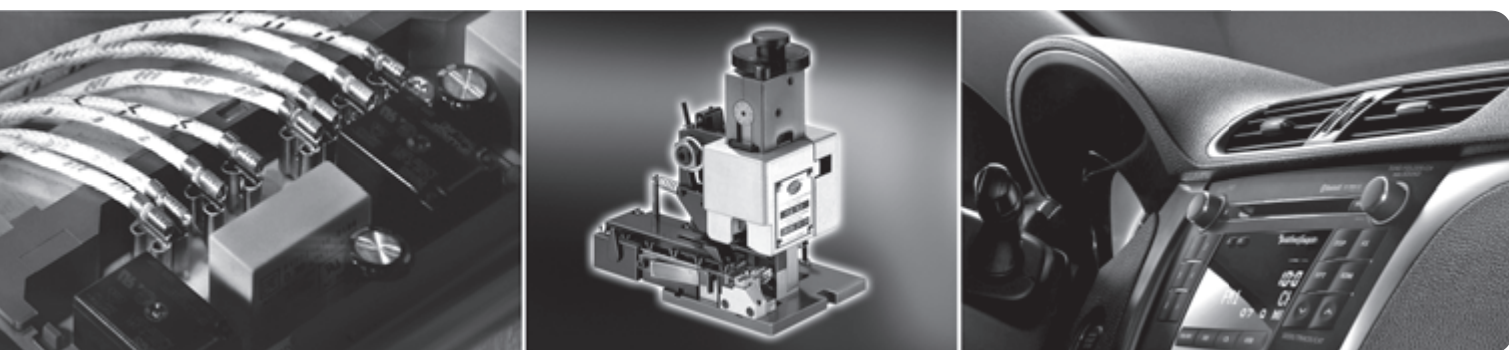

Kontaktadressen Contact addresses

- D Distribution / Distribution
P Zweigwerk / Plant
R Vertretung / Representation
S Tochtergesellschaft / Subsidiary
SO Vertriebsbüro / Sales Office

Deutschland / Germany

Hauptsitz STOCKO Contact GmbH & Co. KG
Simonshöfchen 31
42327 Wuppertal
Tel.: +49 / (0)202 / 97 33 - 0
Fax: +49 / (0)202 / 97 33 - 411
E-Mail: info@stocko-contact.com

P STOCKO Contact GmbH & Co. KG
Olefallstr. 26
53940 Hellenthal
Tel.: +49 / (0)2482 / 84 - 0
Fax: +49 / (0)2482 / 84 - 240
E-Mail: hellenthal@stocko-contact.com

D BAUM electronic GmbH
Schieferstein 6
65439 Flörsheim / Main
Tel.: +49 / (0)6145 / 50 56 - 0
Fax: +49 / (0)6145 / 50 56 - 40
E-Mail: info@baum-electronic.de

D HZ GmbH
Technische Kunststoffe & Elektrische
Verbindungstechnik
Kuchengrund 20
71522 Backnang
Tel.: +49 / (0)7191 / 32 81 - 0
Fax: +49 / (0)7191 / 32 81 - 29
E-Mail: mail@hz-gmbh.com

R Hoppe & Co. Electronic
Inhaber Hans Zeltner e.K.
Gaismannshofstraße 38
90431 Nürnberg
Tel.: +49 / (0)911 / 32 71 75
Fax: +49 / (0)911 / 32 71 41
E-Mail: info@hoppe-electronic.de

D zeb elektroTECHNIK GmbH
Gaismannshofstraße 38
90431 Nürnberg
Tel.: +49 / (0)911/32 39 57-0
Fax: +49 / (0)911/32 71 41
E-Mail: info@zeb-gmbh.de

D ETB Electronic Team
Beratungs- und Vertriebs GmbH
Wundramweg 1
31303 Burgdorf
Tel.: +49 / (0)5136 / 9 72 29-0
Fax: +49 / (0)5136 / 9 72 29-39
E-Mail: info@etb-electronic.de

Australien / Australia

D Braemac Pty Ltd
1/59-61 Burrows Road, Alexandria
Sydney, NSW 2015 Australia
Tel.: +61 / 2 / 95506600
Fax: +61 / 2 / 95506377
E-Mail: info@braemac.com.au

Belgien und Luxemburg / Belgium and Luxembourg

R ATEM N.V./S.A.
Bedrijvenpark De Veert 4
B-2830 Willebroek
Tel.: +32 / 03 / 866 18 00
Fax: +32 / 03 / 866 18 28
E-Mail: info@atem.be

Belarus

D FEK Company
29b, Pushkina pr-t
220015 Minsk
Belarus
Tel.: +375 / 17 / 210 2189
Fax: +375 / 17 / 210 2189
E-Mail: info@fek.by

Brasilien, Argentinien, Uruguay, Paraguay Brazil, Argentina, Uruguay, Paraguay

R STOCKO do Brasil Ltda.
Eng. Jorge Vukotich
Rua América Brasileira, 1400 - Cj.: 123
CEP 04715-002 - São Paulo - S.P. - Brasilien
Tel.: +55 / 11 / 5524 2041
+55 / 11 / 4323 0095
Mobil: +55 / 11 / 8308 3031
Fax: +55 / 11 / 4323 0096
E-Mail: vukotich@stocko.com.br

China / China

R STOCKO Contact GmbH & Co. KG
c/o Wieland Electric
Trading (Shanghai) Co. Ltd.
Unit 2703 Int'l Soho City
889 Renmin Rd, Huang Pu District
PRC-Shanghai 200010
Tel.: +86 / 21 / 63555772-126
63555772-127
Fax: +86 / 21 / 6355 0090
Mobil: +86 - 136 3643 5222
E-Mail: info@stocko-contact.cn

SO STOCKO Contact GmbH & Co. KG
#3-601, No.42 Dongshan 4th Road,
Qingdao 266100, P.R.China
Mobil: +86 / 139 6976 0609
Fax: +86 / 532 / 6687 0622
E-Mail: info@stocko-contact.cn

SO STOCKO Contact GmbH & Co. KG
Room 506,
No. 3 Building of Taoranju Community
Nanshan District
Shenzhen 518055, P.R.China
Mobil: +86 / 138 2378 9179
Fax: +86 / 755 8255 1978
E-Mail: info@stocko-contact.cn

SO STOCKO Contact GmbH & Co. KG
Unit 27-1-401, No.184 Taishan Road
New district Changzhou 213022,
P.R.China
Mobil: +86 / 136 8521 6240
Fax: +86 / 0519 8805 0927
E-Mail: info@stocko-contact.cn

D SIC ELECTRONICS CO. LTD
No.2 factory building,
Export Process Area,
Huanghe East Road
Qingdao Economic & Technical
Development Zone, P.R.China
Postal Code 266555
Tel.: +86 / 750 / 3236 6258
E-Mail: sales@sicchina.com.cn

D WG Industrial Control Equipment
Suit. 112, No. 838, Beisong RD
Minhang District
201111 Shanghai, P.R.China
Tel.: +86 / 21 / 34 53 36 71
Fax: +86 / 21 / 34 31 13 61
E-Mail: sales@wg-ind.com

Dänemark / Denmark

R D Matech Systems ApS
Ankelbovej 6
DK-7190 Billund
Tel.: +45 / 75 33 89 49
Fax: +45 / 75 33 89 46
E-Mail: info@matechsystems.dk

Estland, Lettland, Litauen / Estonia, Latvia, Lithuania

R Adcontact/Gammeter
Paldiski mnt 31
EE - 76606 Keila, Harjumaa
Tel.: +372 / 671 2251
Fax: +372 / 671 2253
Mobil: +372 / 50 89343
E-Mail: info@gammeter.ee

Finnland / Finland

R Adcontact/Gammeter
Naulakatu 3
P.O. Box 627
FIN-33101 Tampere
Tel.: +358 / 3 / 380 22 11
Fax: +358 / 3 / 380 22 44
E-Mail: info@gammeter.fi

Frankreich / France

S STOCKO CONTACT Eurl
7, Route d'Eichhoffen
B.P. 40017 Andlau
67145 - BARR Cedex
Tel.: +33 / (0)3 / 88 58 58 58
Fax: +33 / (0)3 / 88 58 58 88
E-Mail: andlau@stocko-contact.com

R M. Roland DOTIGNY
4 Rue Rougette
60240 Liancourt St Pierre
Tel.: +33 / (0)3 / 44 47 91 68
Fax: +33 / (0)3 / 44 47 91 68
E-Mail: roland.dotigny@stocko-contact.com
(Normandie / Parisienne)

R D CONNECT-SYSTEMES
31, Impasse de la Balme
69800 Saint-Priest
Tel.: +33 / (0) 478 901 315
Fax: +33 / (0) 478 906 332
E-Mail: commercial@connect-systemes.fr
(Rhône-Alpes, Sud, Centre, Est)

Griechenland / Greece

R S. SAKELLIYOU & CO O.E.
Manufacturer's Agents
15B Konstantinidou str.
K. Patissia 104 45 - Athens
Tel.: +30 / 210 / 83 22 611
Fax: +30 / 210 / 83 25 444
E-Mail: sasta@on.gr

Großbritannien / Great Britain

D Cabletrix Ltd
9/10 James Watt Close
Drayton Field Industrial Estate
Daventry, Northants NN11 5QU, UK
Tel.: +44 / 1327 / 876769
Fax: +44 / 1327 / 300130
E-Mail: sales@cabletrix.co.uk

D J-Tronics Ltd
1 Granger Avenue
Acomb
York, YO26 5LF, UK
Tel.: +44 / 1904 / 795690
Fax: +44 / 1904 / 790887
E-Mail: julie@j-tronics.co.uk
If you need a design partner for harnesses
contact: gareth@j-tronics.co.uk

D New Force Ltd
Unit 6, Larkstore Park
Lodge Road
Staplehurst
Kent, TN12 0QY, UK
Tel.: +44 / 1580 / 895111
Fax: +44 / 1580 / 895222
E-Mail: sales@new-force.co.uk

Kontaktadressen Contact addresses

(D) Distribution / Distribution
(P) Zweigwerk / Plant
(R) Vertretung / Representation
(S) Tochtergesellschaft / Subsidiary
(SD) Vertriebsbüro / Sales Office

Indien, Pakistan, Sri Lanka, Bangladesch, Nepal, Bhutan India, Pakistan, Sri Lanka, Bangladesh, Nepal, Bhutan

(D) Sahajanand Impex Pvt. Ltd.
103/104, Magnum Opus,
Shantinagar, Vakola,
Santacruz (East)
Mumbai - 400 055, India
Tel.: +91 / 22 / 66925151
Fax: +91 / 22 / 66921026
E-Mail: sales@sahajanand.com

Irland, Republik / Republic of Ireland

(D) EirKen Enterprises Ltd.
247 Riverforest
Leixlip
Co Kildare, Ireland
Tel.: 00353/1/6156705
Fax: 00353/1/6156704
E-Mail: americ@eirken.ie

Italien / Italy

(R) **(D)** KLEMI Contact Srl
Via G. Marcora, 13
I-20097 San Donato Milanese (Mi)
Tel.: +39 / 02 / 55 60 61 01
Fax: +39 / 02 / 55 60 71 34
E-Mail: klemi@klemi-contact.com

(D) Comarel S.n.c.
Via Montepulciano, 17
I-20124 Milano
Tel.: +39 / 02 / 67 60 611
Fax: +39 / 02 / 67 01 624
E-Mail: comarel@comarel.com

Kanada / Canada

(R) WIELAND Electric Inc.
2889 Brighton
Road Oakville, Ontario L6H 6C9
Tel.: +1 / 905 / 829 84 14
Toll Free: +1 / 800-WIELAND
Fax: +1 / 905 / 829 84 13
E-Mail: oakville@wielandinc.com

Korea / Korea

(D) Sam Tra International
Hoseo Venture Tower 609 Ho
319 Gasan-dong
Geumcheon-gu, Seoul 153-711
Korea
Tel.: +82 / 2 / 26275625
Fax: +82 / 2 / 26275629
E-Mail: sales@samtra.co.kr

Kroatien, Slowakei, Slowenien, Tschechien Croatia, Slovakia, Slovenia, Czechia

(via Codico Partner)

(D) CODICO GmbH
Zwingenstraße 6-8
A-2380 Perchtoldsdorf
Tel.: +43 / 01 / 8 63 05-0
Fax: +43 / 01 / 8 63 05-5000
E-Mail: office@codico.com

Mexiko / Mexico

(SD) STOCKO CONTACT GmbH & Co. KG
Sales Office North America
49 International Road
Burgaw, N.C. 28425
Tel.: +1 / 910 / 259 5050
Fax: +1 / 910 / 259 3691
E-Mail: info@wielandinc.com

Norwegen / Norge

(R) **(D)** Adcontact/Gammeter
P.O. Box 246 Skøyen
N-0213 Oslo
Tel.: +47 224 177 00
Fax: +47 224 177 01
E-Mail: info@adcontact.se

Österreich / Austria

(D) CODICO GmbH
Zwingenstraße 6-8
A-2380 Perchtoldsdorf
Tel.: +43 / 01 / 8 63 05-0
Fax: +43 / 01 / 8 63 05-5000
E-Mail: office@codico.com

Polen / Poland

(R) **(D)** EVOLTEC Tomasz Pawlowski
ul. Postepu 1
02-676 Warszawa
Tel.: +48 / 022 / 8474999
Fax: +48 / 022 / 4907611
E-Mail: info@evoltec.pl

Portugal / Portugal

(R) E. Kramer, LDA.
AP. 3096
Leça da Palmeira
P-4456 Matosinhos
Tel.: +351 / 022 / 9964585
Fax: +351 / 022 / 9964588
E-Mail: ekramerlda@mail.telepac.pt

Russland / Russia

(D) Connectors & Engineering KG
Krasnokazarmennaya 3 build 5
Moscow 111250
Russia
Tel.: +7 / 495 967 15 60
Fax: +7 / 495 967 15 61
E-Mail: sales@faston.ru

(D) ELCO Group LLC
13A, Building 4, Structure 4
Varshavskoye Shosse
Moscow 115230
Tel.: +7 / 495 981 8516
Fax: +7 / 495 775 0255
E-Mail: info@elcogroup.ru

WeiBrussland / Belarus

(D) FEK Company
29b, Pushkina pr-t
220115 Minsk
Belarus
Tel.: +375 / 17 / 210 2189
Fax: +375 / 17 / 210 2189
E-Mail: info@fek.by

Schweden / Sweden

(R) **(D)** Adcontact/Gammeter
Ursviksv. 127B
P.O. Box 7044
S-17407 Sundbyberg
Tel.: +46 / 8 / 445 36 00
Fax: +46 / 8 / 445 36 10
E-Mail: info@adcontact.se

Schweiz / Switzerland

(R) **(D)** AWAG Elektrotechnik AG
Sandbühlstrasse 2
CH-8604 Volketswil
Tel.: +41 / 044 / 908 1919
Fax: +41 / 044 / 908 1999
E-Mail: info@awag.ch

Singapur / Singapore

(SD) STOCKO CONTACT GmbH & Co. KG
Liason Office Singapur
Blk 5, Rivervale Crescent
08-05 Singapore 545084
Mobile: +65 / 91 83 21 31
E-Mail: danny.lee@stocko-asia.com

(D) STOCKO Electronics
Asia Pacific Pte. Ltd.
16 New Industrial Road
01-03/04 Hudson Technocentre
Singapore 536204
Tel.: +65 / 6 345 1788
Fax: +65 / 6 348 6116
E-Mail: info@stocko.com.sg

Spanien / Spain

(SD) STOCKO CONTACT GmbH & Co. KG
Vertriebsbüro Spanien
F. Rius i Taulet, 19-3º
E-08850 Gavà (Barcelona)
Tel.: +34 / 936 / 627 188
Fax: +34 / 936 / 627 188
Mobil: +34 / 676 490 974
E-Mail: diego.vazquez@stocko-contact.com

(D) Otto Rating S.A.
Castellnou, 31-33
E-08017 Barcelona
Tel.: +34 / 93 / 252 27 00
Fax: +34 / 93 / 205 62 64
E-Mail: info@rating.es

Südafrika / South Africa

(R) APT Advanced Product Technology (PTY)
LTD.
Strijdom Park, Randburg
P.O. Box 832
Ferndale 2160
Tel.: +27 / 11 / 792 6010
Fax: +27 / 11 / 792 9879
E-Mail: craig@aptsa.co.za

Türkei / Turkey

(SD) STOCKO CONTACT GmbH & Co. KG
Istanbul Liason Office
Atakoy 11. Kisim, Cigdem D Blok, D:33
34158 Istanbul / TÜRKIYE
Tel.: +90 / 212 / 661 87 10
Fax: +90 / 212 / 661 87 20
E-Mail: info@stockotr.com

Ungarn / Hungary

(R) **(D)** CZINEGE és FIAI Kft.
Pesti ucta 36,
H-5100 - Jászberény
Tel.: +36 / 057 / 500 190
Fax: +36 / 057 / 500 191
E-Mail: czinege@czinege.hu

USA

(SD) STOCKO CONTACT GmbH & Co. KG
Sales Office North America
49 International Road
Burgaw, N.C. 28425
Tel.: +1 / 910 / 259 5050
Fax: +1 / 910 / 259 3691
E-Mail: burgaw@stocko-contact.com

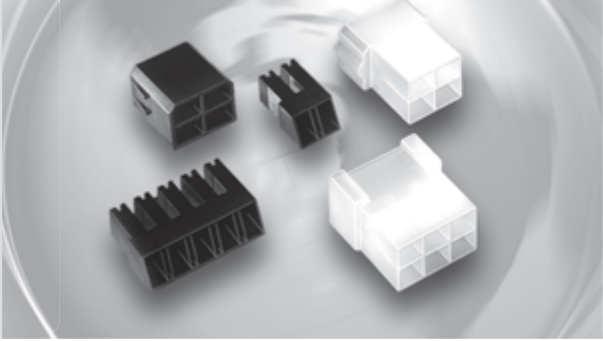

Verarbeitung / Kabelbaumherstellung

Nur sorgfältig verarbeitete Steckverbinder und Kontakte erfüllen in der Anwendung die technischen Anforderungen. STOCKO-Ansetzwerkzeuge und -Maschinen sind auf die besonderen Produkteigenschaften abgestimmt. Prüfstationen überwachen die Qualitätsparameter, um eine hochwertige Verarbeitung der Steckverbinder und Kontakte sicherzustellen.

Für die Einhaltung der STOCKO-Qualitätskriterien auf Verarbeitungseinrichtungen anderer Hersteller trägt der Anwender die alleinige Verantwortung.

- Nur geschultes Personal sollte Steckverbinder und Kontakte verarbeiten.
- Bei der Verarbeitung von Steckverbindern und Kontakten müssen die STOCKO-Verarbeitungsspezifikationen berücksichtigt werden.
- Die Überwachung der produktspezifischen Qualitätsparameter muss nach STOCKO-Vorgaben erfolgen.
- Die eingesetzten Leitungen müssen von STOCKO für das jeweilige Steckverbindersystem oder den Kontakt freigegeben sein.
- Stellen Sie sicher, dass die Isolationsfähigkeit des Steckers nicht durch niederohmige Verbindungen wie Metallspäne, leitende Betriebsstoffe, lose Litzen oder leitende Verunreinigungen herabgesetzt ist, bevor die Stromkreise eingeschaltet werden.

Steckverbinder und Kontakte in der Anwendung

In der Anwendung muss sichergestellt werden, dass die Steckverbinder und Kontakte spezifikationsgemäß eingesetzt werden.

- Die bestimmungsgemäße Funktion einer steckbaren Verbindung wird nur gewährleistet, wenn die Verbindung nach den Vorgaben montiert ist.
- Die zulässige Betriebsspannung hängt von der jeweiligen Anwendung, den gültigen nationalen Bestimmungen und anderen anwendbaren Sicherheitsbestimmungen ab. Die angegebene Betriebsspannung kann deshalb nur als Anhaltswert dienen und muss mit den nationalen Bestimmungen abgeglichen werden.
- Die in den Datenblättern und Spezifikationen angegebenen Temperaturwerte sind Grenztemperaturen und dürfen in der Anwendung nicht überschritten werden.
- Eine Verschmutzung der Steckverbinder und Kontakte darf den jeweils zulässigen Verschmutzungsgrad nicht überschreiten (siehe IEC 60 664). Leitende Verschmutzungen können Kriechströme verursachen. Dabei können Flammen entstehen, die brennbares Material in der Umgebung entzünden und Brände auslösen können.
- Eingeschaltete Stromkreise dürfen nicht durch Abziehen eines Steckers unterbrochen werden. Lichtbögen, Ionisation und ein Brand kann die Folge sein.
- Die Steckverbinderkomponenten mit berührbaren Kontakten sollten nicht auf der Stromversorgungsseite eingesetzt werden, da bei ungesteckten Verbindungen die Gefahr eines elektrischen Schlags besteht.

Sonstige Hinweise

Durch den ständigen Verbesserungsprozess können sich die Produkte ändern. Abweichungen von Beschreibungen, technischen Daten und Darstellungen in den Katalogen sind deshalb möglich. Jede neue Ausgabe eines Kataloges macht vorausgehende Ausgaben ungültig.

Processing / Cable Loom Assembly

Carefully processed connectors and contacts alone will meet the technical requirements in usage. STOCKO assembly tools and machines are adjusted to the specific product properties. Test stations control the quality parameters to safeguard the quality in processing the connectors and contacts.

To assure the STOCKO-quality requirements on processing devices of other manufacturers the user has to take sole responsibility.

- Only trained personnel should process connectors and contacts.
- Processing connectors and contacts the STOCKO manufacturing specifications must be observed.
- Product specific quality parameters must be controlled in accordance with STOCKO instructions.
- Conductors used with the respective connector system or contact must be approved by STOCKO.
- Before switching on the electric current, make sure that the insulating properties of the connector are not compromised by low ohmic connections like metal shavings, conductive materials, lose wires or conductive impurities.

Application of connectors and contacts

When in use make sure that connectors and contacts are applied according to specification.

- The pre-determined function of a connector assembly can only be guaranteed if the connection is assembled according to instruction.
- The permissible operating voltage is subject to application, the legal national specifications and any other applicable safety requirements. The mentioned operating voltage can only serve as a guidance and must be adjusted to national requirements.
- The temperature values indicated in the data sheets are border-line temperatures and must not be surpassed under operating conditions.
- Contaminated connectors and contacts must not exceed the permissible degree of contamination (see IEC 60 664). Conductive contaminations can lead to creepage currents. They can create combustions that inflame surrounding inflammable materials and start fires.
- Switched-on circuitry must not be interrupted by pulling the plug. The result may be electric arcs, ionisation and fires.
- Connector components with touchable contacts must not be used as mains connections as unplugged connections can endanger electric shocks.

Further Information

The products can be changed due to improvements. Changes and alterations from descriptions, technical data and illustrations in the catalogues are possible. Every new catalogue will make all earlier published versions invalid.

STOCKO CONTACT GmbH & Co. KG

Simonshöfchen 31
D-42327 Wuppertal

Tel. +49 (0)202 / 97 33 - 0
Fax +49 (0)202 / 97 33 - 411

e-mail info@stocko-contact.com
Internet www.stocko-contact.com

Ein Unternehmen der Wieland Gruppe
A Member of the Wieland Group



Wuppertal / Deutschland

Andlau / Frankreich

Hellenthal / Deutschland



Ref. Nr. 378407
Printed in Germany 9 / 12

