



... für den Leistungsbereich
... for High-Current Applications

» Firmenprofil «

Company profile

Unsere Produkte:

- Steckverbindersysteme mit Schneidklemm-, Crimp- oder Lötanschluss
- Lötfreie Verbinder
- Crimpkontakte
- Kundenspezifische Sonderentwicklungen
- Verarbeitungs-Systeme für alle STOCKO-Produkte: Handzangen, Halb- und Vollautomaten

Unsere Märkte:

- Hausgerätetechnik
- Heizungstechnik
- Industrie
- Automotive
- Distribution

Gesicherte Qualität

DQS-zertifizierte integrierte Managementsysteme

- Zertifiziert nach ISO 9001 und ISO/ TS 16949
STOCKO CONTACT Deutschland, Frankreich
- Zertifiziert nach ISO 14001
STOCKO CONTACT, Frankreich
- Zertifizierungsgesellschaft: DQS GmbH, Frankfurt

Our Products:

- Multi-way connector systems with terminations for insulation displacement crimping or soldering
- Solderless terminals
- Crimp contacts
- Customers' special products
- Terminating systems for all STOCKO products: Hand tools, semi- and fully automated machines

Our Markets:

- Domestic appliances industry
- Heating industry
- Industrial electronics
- Automotive
- Distribution

Assured Quality

DQS-certified integrated management systems

- Certified according to ISO 9001 and ISO/ TS 16949
STOCKO CONTACT Germany, France
- Certified according to ISO 14001
STOCKO CONTACT, France
- Approval company: DQS GmbH, Frankfurt

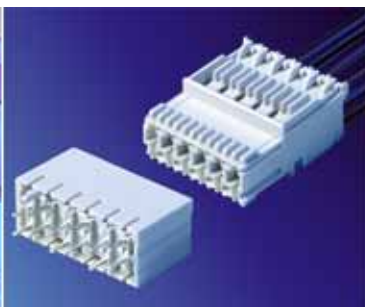

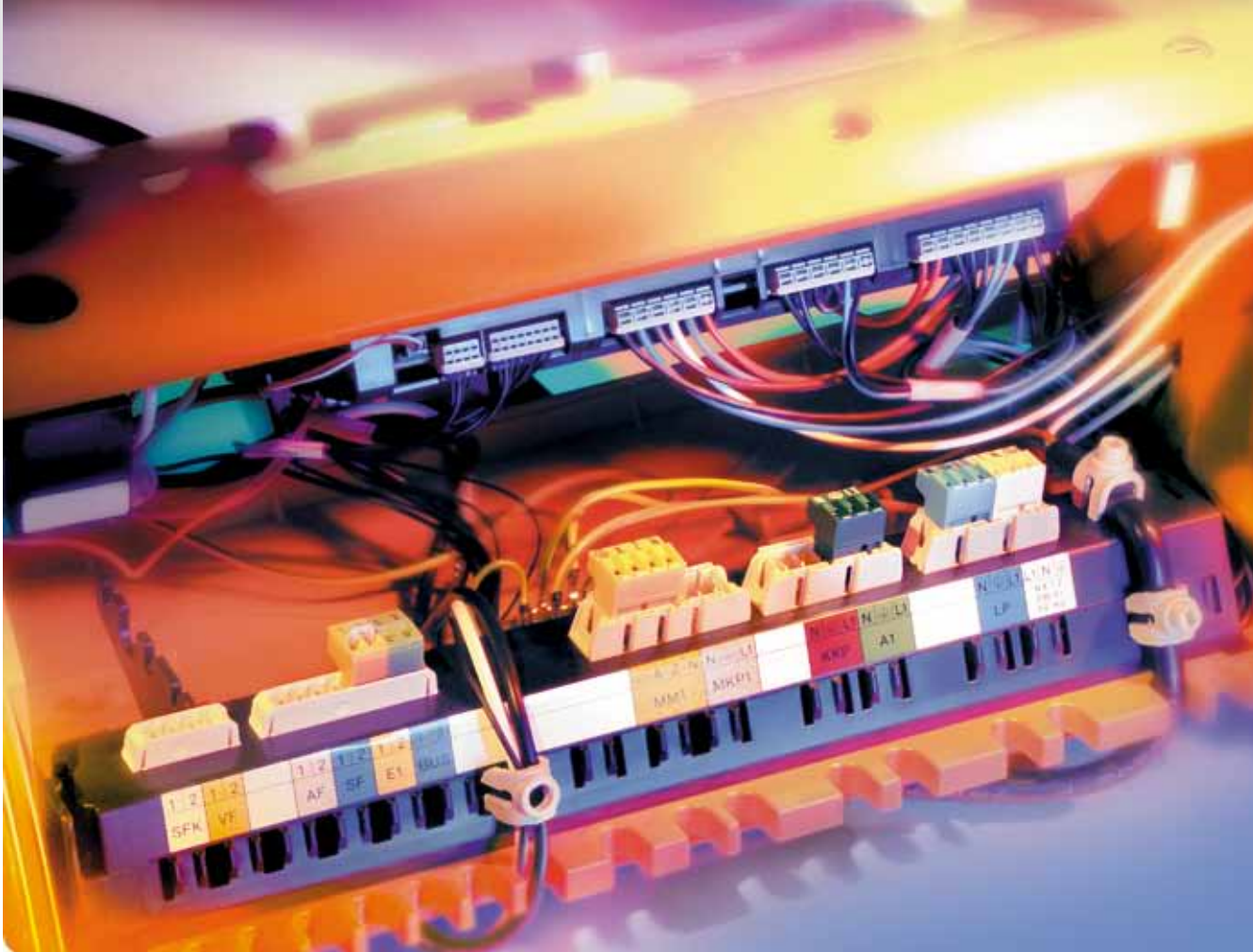

Gründung

- 1901 in Wuppertal

Founded

- 1901 in Wuppertal

Mitarbeiter weltweit

- 450

Employees World-wide

- 450

Werke

- Wuppertal / Deutschland
- Hellenthal / Deutschland
- Andlau / Frankreich
- Sokolov / Tschechien
- Shanghai / China

Factories

- Wuppertal / Germany
- Hellenthal / Germany
- Andlau / France
- Sokolov / Czech Republic
- Shanghai / China



» Sichere Kontakte. Weltweit.« Secure Connections. World-wide.

STOCKO zählt heute zu den führenden europäischen Anbietern von elektromechanischen Bauelementen. Aus gutem Grund. Denn seit mehr als hundert Jahren konzentrieren wir uns bei der täglichen Arbeit auf das Wesentliche: die Zufriedenheit unserer Kunden. Es ist nicht selbstverständlich, über eine so lange Zeit allen Erwartungen gerecht zu werden. Die Bauelementebranche ist eine Schlüsselindustrie, die keine Fehler verzeiht, und die Kundenwünsche so vielfältig wie anspruchsvoll sind. Sie fordern immer wieder unseren ganzen Einsatz – angefangen bei Forschung und Entwicklung, bis hin zu Logistik und Vertrieb. Aus diesem Grund haben wir unsere Kunden von Anfang an in zahlreiche Prozesse, vor allem aber in die Qualitätssicherung eingebunden. Nur so können wir innovative Entwicklungen und Verfahrenstechniken auf den Weg bringen. Und nur so können wir auf Dauer unsere Produkte auf konsequent hohem Niveau anbieten. Produkte, die sich in der Heizungssteuerung und in Getränkeautomaten genauso finden wie im Geschirrspüler oder im Automobil. Wenn wir bei STOCKO also von sicheren Kontakten sprechen, dann deshalb, weil in jedem unserer Steckverbinder die Überzeugung mitschwingt, dass gute Verbindungen immer auch Vertrauenssache sind.

Today, STOCKO is one of the leading European manufacturers of electro-mechanical components; for very good reasons, because, for more than one hundred years, we are focussed in our daily work on the most important object, to satisfy our customers. Of course, it is not easy to meet these expectations over such a long period of time. Electronic component manufacturing is a key industry that does not tolerate mistakes, and customers' requirements are very complex and challenging. Again and again, they demand our full efforts beginning with research and development and finally in logistics and marketing. Hence we invite our customers' involvement in numerous stages of production processes but above all with regard to quality assurance, right from the beginning, and thus make sure that we continue to offer our products at a high quality level. Products that can be found equally in heating controls, drink dispensing machines, dish washers or motor cars. If, at STOCKO, we talk of secure connections then for this reason that in every one of our connectors an element of conviction reverberates that good connections are always a matter of trust.



» Inhalt « Index

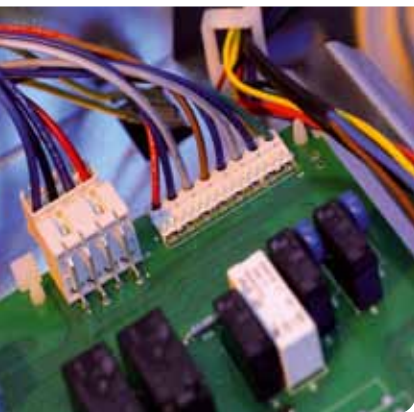











	Seite Page		Seite Page
Kombinationsmöglichkeiten Combination alternatives	4-7	Steckverbindersystem Raster 11,4 mm Connector system pitch 11,4 mm	
		TL 4	91
Steckverbindersystem Raster 2,5 mm Connector system pitch 2.5 mm		Codierungen Polarizing	92-104
ECO-TRONIC	8-21	Verpackungseinheiten Standard packing	105-109
Steckverbindersysteme Raster 5 mm Connector systems pitch 5 mm		Verarbeitung Terminating technology	110-123
ECO-TRONIC pro	22-27	Vergleichstabellen Cross reference lists	124-125
TL 1	28-35	Allgemeine Sicherheitshinweise General safety informations	126-127
ECO-DOMO	36-55		
ECO-DOMO FT.....	56-59		
ECO-DOMO TI.....	60-63		
ECO-FLEX	64-75		
MTL 2 S	76-83		
RAST 5 Crimp.....	84-88		
ECO-DOMO PM	84-85/89		
Steckverbindersystem Raster 8 mm Connector system pitch 8 mm			
TL 3 HT	90		

Technische Änderungen vorbehalten.
We reserve the right to alter technical details.
WEEE-Reg.-Nr. DE 14484959



Kombinationsmöglichkeiten

ECO-TRONIC, ECO-TRONIC pro, TL 1

		ECO-TRONIC			
▽ Stiftwannen Pin connectors	Federgehäuse ▷ IDC housings				
	▽ Serie / Series ▷	MF 7234	MF 7236	MF 7237	MF 7238
Seite / Page		10	11	12	13
15	 MS 7230	•			
26					
16	 MS 7231		•	•	
17	 MS 7232	•			
27					
18	 MS 7246	•			
19		MS 7247	•		
21	 MS 7320	•			
20	 MS 7250	•			
					
	außermittig non-centered				•
	mittig centered				•
	Platinenrand geschlitzt PCB edge slot position				•
34	 MTL 1 S 8180				
35		MTL 1 S 8200			
33	 MTL 1 H 485				











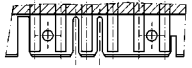

Combination alternatives

ECO-TRONIC, ECO-TRONIC pro, TL 1

		ECO-TRONIC pro		TL 1	
					
MF 7242	MF 7260	MF 7262	MTL 1 F 6670	MTL 1 F 6690	MTL 1 F 6710
14	24	25	30	31	32
	•				
	•				
	•				
	•				
	•				
			•		
•		•		•	
•		•			•
				•	
				•	
					•







Kombinationsmöglichkeiten

ECO-DOMO, Rast 5 Crimp, ECO-FLEX M

		ECO-DOMO				
▽ Messerleisten Tab connectors	Federgehäuse ▷ IDC housings					
	▽ Serie / Series ▷	MF 9260 / 9560	MF 9586 / 9561	MF 9562	MF 9264 / 9564	MF 9286 / 9261
Seite / Page		46 / 47	50 / 51	48	52 / 53	49
 Platinenrand geschlitzt PCB edge slot position	außermittig non-centered					
	mittig centered					
	außen edge					
83		MTL 2 S 7770				
82		MTL 2 S 8450	●	●	●	●
81		MTL 2 S 8470	●	●	●	●
78		MTL 2 S 8430		●	●	●
79		MTL 2 S 8580	●	●	●	●
80		MTL 2 S 8600	●	●	●	●
66	 	MS 9401	●	●	●	●
67		MS 9402		●	●	●
68		MS 9403	●	●	●	●
69		MS 9404	●	●	●	●
70		MS 9405	●	●	●	●
71		MS 9406	●	●	●	●
71		MS 9408				
72		MS 9407				
73		MS 9481	●	●	●	●
89		MS 9450	●	●	●	●
62		MS 9460	●	●	●	●
63		MS 9470	●	●	●	●

Combination alternatives

ECO-DOMO, Rast 5 Crimp, ECO-FLEX M

ECO-DOMO				ECO-DOMO FT	RAST 5 Crimp		
							
MF 9285	MF 9585	MF 9290	MF 9590	MF 9761 / 9785	EH 688	EH 688.400	EH 699
54	55	38	39	58 / 59	86	87	88
		•	•				
		•	•				
					•	•	•
•	•			•		•	•
•	•			•		•	•
•	•			•		•	•
•	•			•		•	•
•	•			•		•	•
•	•			•		•	•
•	•			•		•	•
•	•			•		•	•
•	•			•		•	•
•	•			•		•	•
•	•			•		•	•
•	•			•		•	•
•	•			•		•	•
					•	•	•
					•	•	•
•	•			•			
•	•			•	•	•	•
•	•			•	•	•	•
•	•			•	•	•	•

»Steckverbindersystem ECO-TRONIC« Connector system ECO-TRONIC

Systembeschreibung

Federgehäuse

- Direkt- und Indirektsteckverbinder mit Schneidklemmanschluß entsprechend der Weißgeräte-Spezifikation RAST 2,5
- Große Luft- und Kriechstrecken durch geschlossene Kabelschächte
- Hohe Anzahl unwechselbarer Stecker durch Codierstiftschneiden
- Als Direktstecker erfolgen Codierung und Verrastung auf der Platine

Stiftwannen

- In stehender und liegender Ausführung für senkrechtes oder waagerechtes Stecken
- In SMT-Ausführung für senkrechtes Stecken

Schottdurchführung

- Stiftwanne mit Schneidklemmanschluß für Gerätewanddurchführungen
- Verrastbar in Blechdicke $0,8 \pm 0,1$ mm.

Bestellbeispiel

Stiftwanne, 3polig, uncodiert, vollbestückt für senkrechtes Stecken

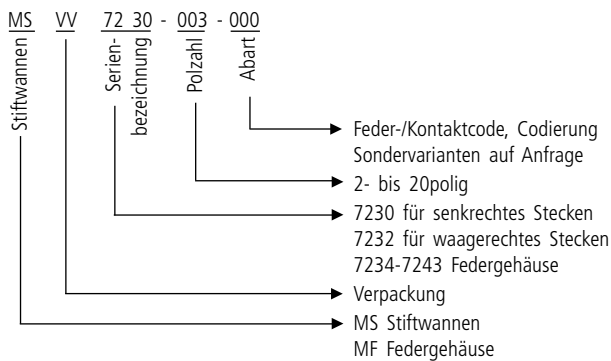

Description of system

IDC housings

- Direct and indirect connectors with IDC termination in accordance with the RAST 2.5 standard specification for domestic appliances
- Closed cable entries ensure long air and creepage distances
- Trimming polarizing pegs to individual requirements produces a large number of clearly defined connector combinations
- With direct edge versions, polarizing and locking feature for PCB

Pin connectors

- In vertical and horizontal versions facilitate 90° and 180° cable angles
- SMT version for vertical PC board assembly

Pin connector panel mount

- Pin connector with IDC termination for entry through back panel
- Lockable in metal thickness 0.8 ± 0.1 mm

Example for ordering

3-way pin connector, unpolarized, fully assembled for vertical connections

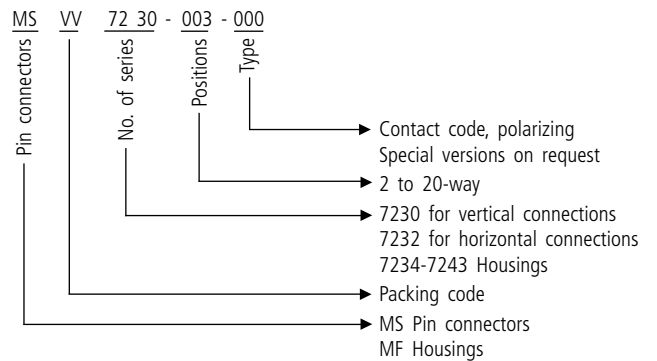

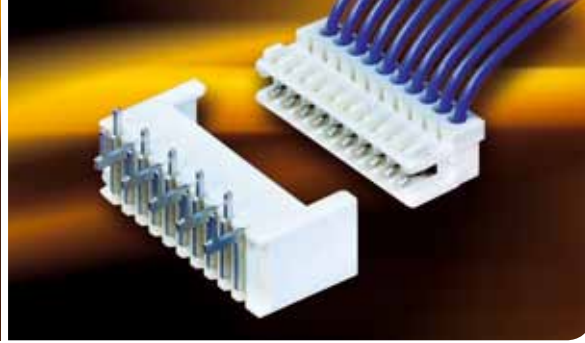

Technische Daten

Mechanisch

Raster	2,5 mm
Polzahl	2 - 20
Anschlußart	Schneidklemmtechnik
Leiterquerschnitt	0,22 - 0,35 mm ²
Isolations Ø	max. 1,6 mm
Isolationshärte	Shore A 90° ± 5
Leiteraufbau	Massiv, Litze
Temperaturbereich	-40 °C ...+ 120 °C
Leiterplattendicke	1,55 ± 0,19 mm

Elektrisch

Bemessungsstrom	2 A
Bemessungsspannung	Raster 2,5 mm: 32 V Raster 5 mm: 250 V
Durchschlagfestigkeit Gehäusematerial	Vollbestückung 2,5 mm: 1,4 kV Teilbestückung 5 mm: 2,8 kV
Isolationswiderstand	> 10 ⁹ Ω
Durchgangswiderstand	< 10 m Ω
Luft- und Kriechstrecken	Raster 2,5 mm: > 1 mm Raster 5 mm: > 3 mm
Kriechstromfestigkeit Freigaben	CTI ≥ 400 DIN EN 61984 (IEC 61984) UL / ULC E96569

Werkstoffe

Kontakt	Feder: CuSn, Cu-Legierung Stift: CuZn
Kontaktoberfläche	Feder: Sn, NiAu Stift: NiSn
Isolierkörper	PA, glühdrahtbeständig, GWT 750°C nach IEC 60335-1
SMT Stiftwanne	PA, glühdrahtbeständig, GWT 750°C nach IEC 60335-1
Gehäusefarbe	natur, schwarz
Codierung	nach RAST 2,5

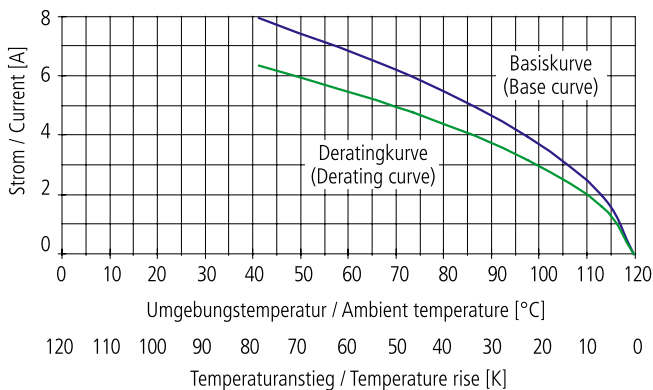

Technical data

Mechanical

Pitch	2.5 mm
Positions	2 - 20
Termination	IDC
Wire size	0.22 - 0.35 mm ²
Insulation Ø	max. 1.6 mm
Hardness of insulation	Shore A 90° ± 5
Type of wire	solid, stranded
Temperature range	-40 °C ...+ 120 °C
Board thickness	1.55 ± 0.19 mm

Electrical

Current rating	2 A
Nom. voltage	Pitch 2.5 mm: 32 V Pitch 5 mm: 250 V
Dielectrical strength	Fully assembled 2.5 mm: 1.4 kV Partially assembled 5 mm: 2.8 kV
Insulation resistance	> 10 ⁹ Ω
Contact resistance	< 10 m Ω
Air gap and creeping distances	Pitch 2.5 mm: > 1 mm Pitch 5 mm: > 3 mm
Tracking resistance	CTI ≥ 400
Approved by	DIN EN 61984 (IEC 61984) UL / ULC E96569

Materials

Contact	Socket: CuSn, Cu-alloy Pin: CuZn
Contact finishing	Socket: Sn, NiAu Pin: NiSn
Housing	PA, glow wire resistant, GWT 750°C acc. to IEC 60335-1
SMT pin connector	PA, glow wire resistant, GWT 750°C acc. to IEC 60335-1
Colour of housing	natural, black
Polarizing	to RAST 2.5

Derating-Kurve / Derating curve

Leiterquerschnitt: 0,35 mm² / 19-poliger Stecker / Direktsteckung
Wire size: 0.35 mm² / 19-way connector / on PCB



Serie MF 7234

Federgehäuse in Schneidklemmtechnik

Series MF 7234

IDC housings

Serie MF 7234 für Einzelleiter zum direkten und indirekten Stecken Series MF 7234 for discrete wire for direct and indirect connections



Darstellung vormontiert
Designation pre-assembled

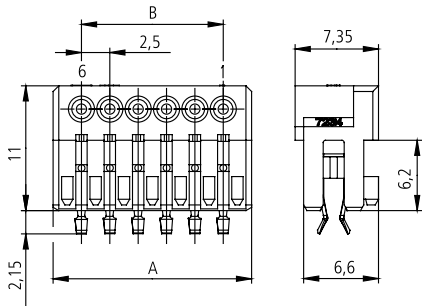

Darstellung ohne Kontakte
Designation without contacts

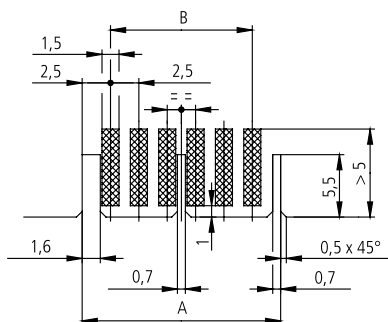
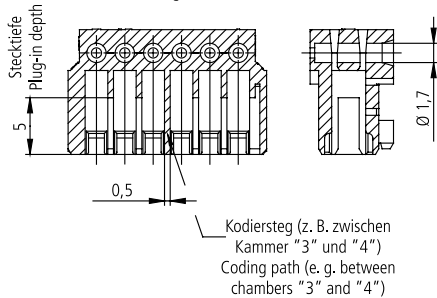

Polzahl Positions	Artikel-Nummer Part number	Abmessungen A Dimensions A	Abmessungen B Dimensions B
2	MFVV 7234 - 202 - *	2er Riegel / 2 housings in chain	
3	MFVV 7234 - 003 - *	10,0	5,0
4	MFVV 7234 - 004 - *	12,5	7,5
5	MFVV 7234 - 005 - *	15,0	10,0
6	MFVV 7234 - 006 - *	17,5	12,5
7	MFVV 7234 - 007 - *	20,0	15,0
8	MFVV 7234 - 008 - *	22,5	17,5
9	MFVV 7234 - 009 - *	25,0	20,0
10	MFVV 7234 - 010 - *	27,5	22,5
11	MFVV 7234 - 011 - *	30,0	25,0
12	MFVV 7234 - 012 - *	32,5	27,5
13	MFVV 7234 - 013 - *	35,0	30,0
14	MFVV 7234 - 014 - *	37,5	32,5
15	MFVV 7234 - 015 - *	40,0	35,0
16	MFVV 7234 - 016 - *	42,5	37,5
17	MFVV 7234 - 017 - *	45,0	40,0
18	MFVV 7234 - 018 - *	47,5	42,5
19	MFVV 7234 - 019 - *	50,0	45,0
20	MFVV 7234 - 020 - *	52,5	47,5

- * Vorzugstypen siehe Seiten 92 / 93. Codierungen, Teilbestückungen im Rastermaß 5 mm und Sonderbestückungen auf Anfrage
- * Preferential types see page 92 / 93. Polarizings, part assemblies in 5 mm spacing, special contact loading on request

Serie MF 7236

Federgehäuse in Schneidklemmtechnik

Series MF 7236

IDC housings

Serie MF 7236 für Einzelleiter zum direkten und indirekten Stecken, mit Innenverrastung
Series MF 7236 for discrete wire for direct and indirect connections, with locking feature inside



Darstellung vormontiert
Designation pre-assembled

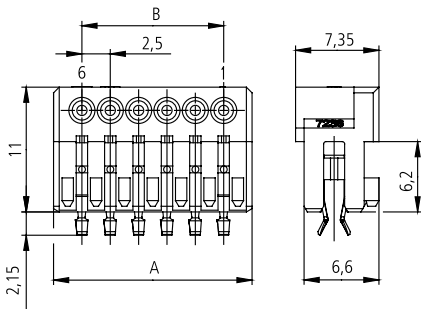

Darstellung ohne Kontakte
Designation without contacts

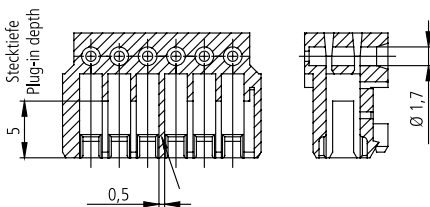

Kodiersteg (z. B. zwischen
Kammer "3" und "4")
Coding path (e. g. between
chambers "3" and "4")

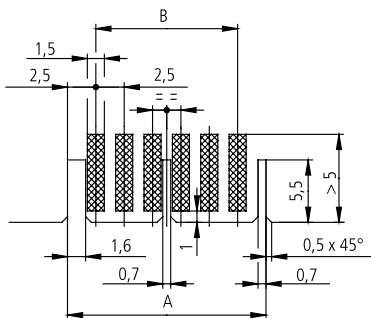

Polzahl Positions	Artikel-Nummer Part number	Abmessungen A Dimensions A	Abmessungen B Dimensions B
2	MFVV 7236 - 202 - *	2er Riegel / 2 housings in chain	
3	MFVV 7236 - 003 - *	10,0	5,0
4	MFVV 7236 - 004 - *	12,5	7,5
5	MFVV 7236 - 005 - *	15,0	10,0
6	MFVV 7236 - 006 - *	17,5	12,5
7	MFVV 7236 - 007 - *	20,0	15,0
8	MFVV 7236 - 008 - *	22,5	17,5
9	MFVV 7236 - 009 - *	25,0	20,0
10	MFVV 7236 - 010 - *	27,5	22,5
11	MFVV 7236 - 011 - *	30,0	25,0
12	MFVV 7236 - 012 - *	32,5	27,5
13	MFVV 7236 - 013 - *	35,0	30,0
14	MFVV 7236 - 014 - *	37,5	32,5
15	MFVV 7236 - 015 - *	40,0	35,0
16	MFVV 7236 - 016 - *	42,5	37,5
17	MFVV 7236 - 017 - *	45,0	40,0
18	MFVV 7236 - 018 - *	47,5	42,5
19	MFVV 7236 - 019 - *	50,0	45,0
20	MFVV 7236 - 020 - *	52,5	47,5

- * Codierungen, Teilbestückungen im Rastermaß 5 mm und Sonderbestückungen auf Anfrage.
- * Polarizings, part assemblies in 5 mm spacing, special contact loading on request.

Serie MF 7237

Federgehäuse in Schneidklemmtechnik

Series MF 7237

IDC housings

Serie MF 7237 für Einzelleiter als Busverbinder mit Innenverrastung

Series MF 7237 for discrete wire daisy chain connector with locking feature inside



Darstellung vormontiert
Designation pre-assembled

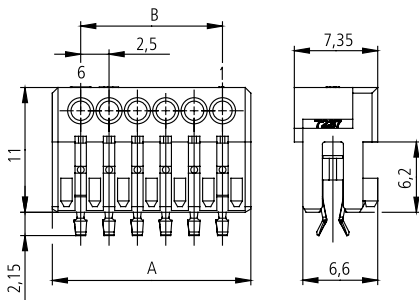

Darstellung ohne Kontakte
Designation without contacts

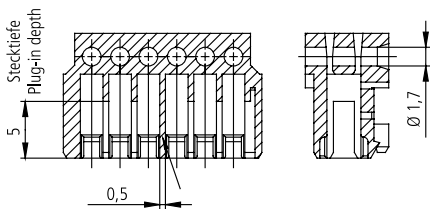

Kodiersteg (z. B. zwischen
Kammer "3" und "4")
Coding path (e. g. between
chambers "3" and "4")

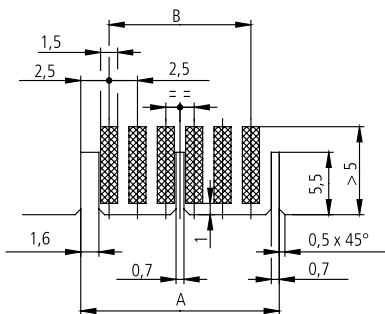

Polzahl Positions	Artikel-Nummer Part number	Abmessungen A Dimensions A	Abmessungen B Dimensions B
2	MFVV 7237 - 202 - *	2er Riegel / 2 housings in chain	
3	MFVV 7237 - 003 - *	10,0	5,0
4	MFVV 7237 - 004 - *	12,5	7,5
5	MFVV 7237 - 005 - *	15,0	10,0
6	MFVV 7237 - 006 - *	17,5	12,5
7	MFVV 7237 - 007 - *	20,0	15,0
8	MFVV 7237 - 008 - *	22,5	17,5
9	MFVV 7237 - 009 - *	25,0	20,0
10	MFVV 7237 - 010 - *	27,5	22,5
11	MFVV 7237 - 011 - *	30,0	25,0
12	MFVV 7237 - 012 - *	32,5	27,5
13	MFVV 7237 - 013 - *	35,0	30,0
14	MFVV 7237 - 014 - *	37,5	32,5
15	MFVV 7237 - 015 - *	40,0	35,0
16	MFVV 7237 - 016 - *	42,5	37,5
17	MFVV 7237 - 017 - *	45,0	40,0
18	MFVV 7237 - 018 - *	47,5	42,5
19	MFVV 7237 - 019 - *	50,0	45,0
20	MFVV 7237 - 020 - *	52,5	47,5

- * Codierungen, Teilbestückungen im Rastermaß 5 mm und Sonderbestückungen auf Anfrage.
- * Polarizings, part assemblies in 5 mm spacing, special contact loading on request.

Serie MF 7238

Federgehäuse in Schneidklemmtechnik

Series MF 7238

IDC housings

Serie MF 7238 für Einzelleiter zum direkten Stecken, mit PCB-Verrastung ohne Kammverlustr
Series MF 7238 for discrete wire for direct connections, with PCB locking without loss of contact



Darstellung vormontiert
Designation pre-assembled

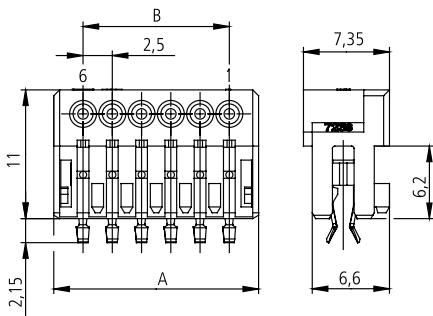

Darstellung ohne Kontakte
Designation without contacts

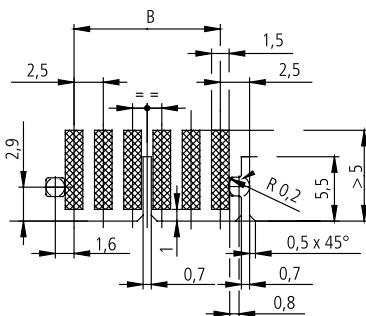
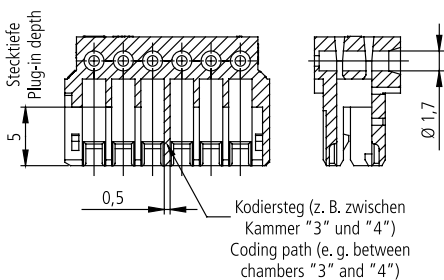

Polzahl Positions	Artikel-Nummer Part number	Abmessungen A Dimensions A	Abmessungen B Dimensions B
2	MFVV 7238 - 202 - *	2er Riegel / 2 housings in chain	
3	MFVV 7238 - 003 - *	10,0	5,0
4	MFVV 7238 - 004 - *	12,5	7,5
5	MFVV 7238 - 005 - *	15,0	10,0
6	MFVV 7238 - 006 - *	17,5	12,5
7	MFVV 7238 - 007 - *	20,0	15,0
8	MFVV 7238 - 008 - *	22,5	17,5
9	MFVV 7238 - 009 - *	25,0	20,0
10	MFVV 7238 - 010 - *	27,5	22,5
11	MFVV 7238 - 011 - *	30,0	25,0
12	MFVV 7238 - 012 - *	32,5	27,5
13	MFVV 7238 - 013 - *	35,0	30,0
14	MFVV 7238 - 014 - *	37,5	32,5
15	MFVV 7238 - 015 - *	40,0	35,0
16	MFVV 7238 - 016 - *	42,5	37,5
17	MFVV 7238 - 017 - *	45,0	40,0
18	MFVV 7238 - 018 - *	47,5	42,5
19	MFVV 7238 - 019 - *	50,0	45,0
20	MFVV 7238 - 020 - *	52,5	47,5

mit Codiersteg und wahlweise geschlossenen Stirnseiten
with polarizing bar and optionally fully closed front

- * Vorzugstypen siehe Seiten 94 / 95. Codierungen, Teilbestückungen im Rastermaß 5 mm und Sonderbestückungen auf Anfrage
- * Preferential types see page 94 / 95. Polarizings, part assemblies in 5 mm spacing, special contact loading on request

Serie MF 7242

Federgehäuse in Schneidklemmtechnik

Series MF 7242

IDC housings

Serie MF 7242 für Einzelleiter mit Codiersteg und aktiver PCB-Verrastung Series MF 7242 for discrete wire with polarizing bar and active PCB locking

Polzahl Positions	Artikel-Nummer Part number	Abmessungen A Dimensions A	Abmessungen B Dimensions B
3	MFVV 7242 - 003 - *	10,0	5,0
4	MFVV 7242 - 004 - *	12,5	7,5
5	MFVV 7242 - 005 - *	15,0	10,0
6	MFVV 7242 - 006 - *	17,5	12,5
7	MFVV 7242 - 007 - *	20,0	15,0
8	MFVV 7242 - 008 - *	22,5	17,5
9	MFVV 7242 - 009 - *	25,0	20,0
10	MFVV 7242 - 010 - *	27,5	22,5
11	MFVV 7242 - 011 - *	30,0	25,0
12	MFVV 7242 - 012 - *	32,5	27,5
13	MFVV 7242 - 013 - *	35,0	30,0
14	MFVV 7242 - 014 - *	37,5	32,5
15	MFVV 7242 - 015 - *	40,0	35,0
16	MFVV 7242 - 016 - *	42,5	37,5
17	MFVV 7242 - 017 - *	45,0	40,0
18	MFVV 7242 - 018 - *	47,5	42,5
19	MFVV 7242 - 019 - *	50,0	45,0
20	MFVV 7242 - 020 - *	52,5	47,5

Kammerverlust durch aktive PCB-Verrastung Loss of contact for active PCB locking

- * Vorzugstypen siehe Seiten 96 / 97. Codierungen, Teilbestückungen im Rastermaß 5 mm und Sonderbestückungen auf Anfrage
- * Preferential types see page 96 / 97. Polarizings, part assemblies in 5 mm spacing, special contact loading on request

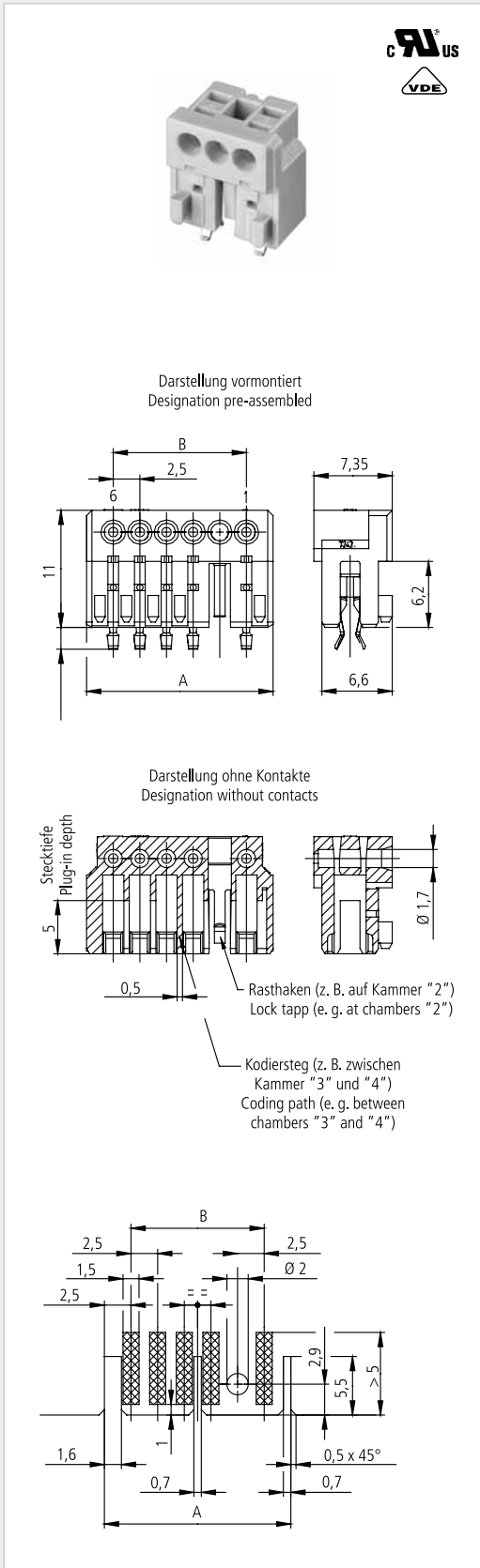

Serie MS 7230

Stiftwannen für Serie MF 7234

Series MS 7230

Pin connectors for series MF 7234

Serie MS 7230, nach RAST 2,5 für senkrechtes Stecken

Series MS 7230, to RAST 2.5 for vertical connections

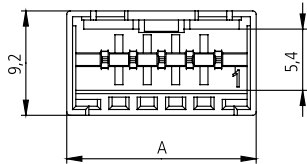
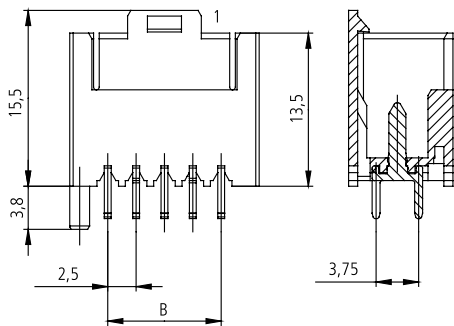
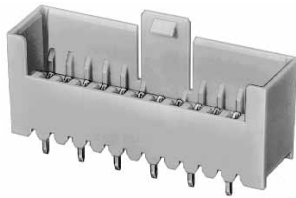

Lochbild (Bauteilseite)
PCB layout (component side)

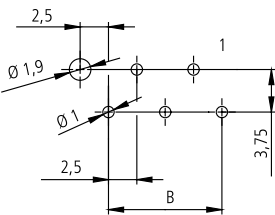

Lochbild 250 V (Bauteilseite)
PCB layout 250 V (component side)

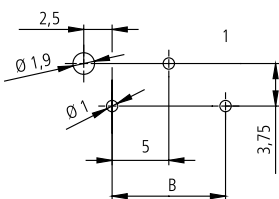

Polzahl Positions	Artikel-Nummer Part number	Abmessungen A Dimensions A	Abmessungen B Dimensions B	
3	MSVV 7230 - 003 - 0 *	11,7	5,0	
4	MSVV 7230 - 004 - 0 *	14,2	7,5	
5	MSVV 7230 - 005 - 0 *	16,7	10,0	
6	MSVV 7230 - 006 - 0 *	19,2	12,5	
7	MSVV 7230 - 007 - 0 *	21,7	15,0	
8	MSVV 7230 - 008 - 0 *	24,2	17,5	
9	MSVV 7230 - 009 - 0 *	26,7	20,0	
10	MSVV 7230 - 010 - 0 *	29,2	22,5	
11	MSVV 7230 - 011 - 0 *	31,7	25,0	
12	MSVV 7230 - 012 - 0 *	34,2	27,5	
13	MSVV 7230 - 013 - 0 *	36,7	30,0	
14	MSVV 7230 - 014 - 0 *	39,2	32,5	
15	MSVV 7230 - 015 - 0 *	41,7	35,0	
16	MSVV 7230 - 016 - 0 *	44,2	37,5	
17	MSVV 7230 - 017 - 0 *	46,7	40,0	
18	MSVV 7230 - 018 - 0 *	49,2	42,5	
19	MSVV 7230 - 019 - 0 *	51,7	45,0	
20	MSVV 7230 - 020 - 0 *	54,2	47,5	

- * Codierungen, Teilbestückungen im Rastermaß 5 mm und Sonderbestückungen auf Anfrage.
- * Polarizings, part assemblies in 5 mm spacing and special contact loading on request.

Serie MS 7231

Stiftwannen für Serien MF 7236, 7237

Series MS 7231

Pin connectors for series MF 7236, 7237

Serie MS 7231, nach RAST 2,5 für senkrecht Stecken

Series MS 7231, to RAST 2.5 for vertical connections

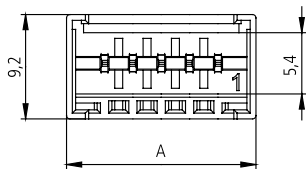
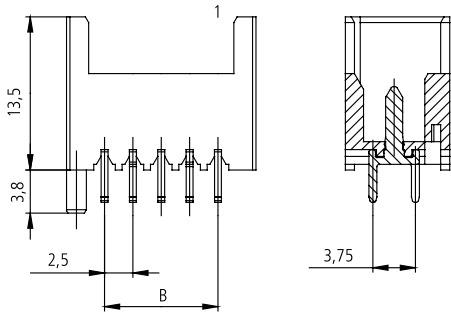

Lochbild (Bauteilseite)
PCB layout (component side)

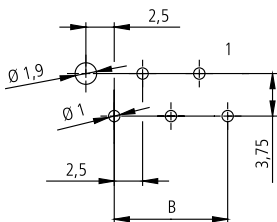

Polzahl Positions	Artikel-Nummer Part number	Abmessungen A Dimensions A	Abmessungen B Dimensions B
3	MSVV 7231 - 003 - 0 *	11,7	5,0
4	MSVV 7231 - 004 - 0 *	14,2	7,5
5	MSVV 7231 - 005 - 0 *	16,7	10,0
6	MSVV 7231 - 006 - 0 *	19,2	12,5
7	MSVV 7231 - 007 - 0 *	21,7	15,0
8	MSVV 7231 - 008 - 0 *	24,2	17,5
9	MSVV 7231 - 009 - 0 *	26,7	20,0
10	MSVV 7231 - 010 - 0 *	29,2	22,5
11	MSVV 7231 - 011 - 0 *	31,7	25,0
12	MSVV 7231 - 012 - 0 *	34,2	27,5
13	MSVV 7231 - 013 - 0 *	36,7	30,0
14	MSVV 7231 - 014 - 0 *	39,2	32,5
15	MSVV 7231 - 015 - 0 *	41,7	35,0
16	MSVV 7231 - 016 - 0 *	44,2	37,5
17	MSVV 7231 - 017 - 0 *	46,7	40,0
18	MSVV 7231 - 018 - 0 *	49,2	42,5
19	MSVV 7231 - 019 - 0 *	51,7	45,0
20	MSVV 7231 - 020 - 0 *	54,2	47,5

- * Codierungen, Teilbestückungen im Rastermaß 5 mm und Sonderbestückungen auf Anfrage.
- * Polarizing, part assemblies in 5 mm spacing and special contact loading on request.

Serie MS 7232

Stiftwannen für Serie MF 7234

Series MS 7232

Pin connectors for series MF 7234

Serie MS 7232, nach RAST 2,5 für waagerechtes Stecken Series MS 7232, to RAST 2.5 for horizontal connections

Polzahl Positions	Artikel-Nummer Part number	Abmessungen A Dimensions A	Abmessungen B Dimensions B
3	MSVV 7232 - 003 - 0 *	11,7	5,0
4	MSVV 7232 - 004 - 0 *	14,2	7,5
5	MSVV 7232 - 005 - 0 *	16,7	10,0
6	MSVV 7232 - 006 - 0 *	19,2	12,5
7	MSVV 7232 - 007 - 0 *	21,7	15,0
8	MSVV 7232 - 008 - 0 *	24,2	17,5
9	MSVV 7232 - 009 - 0 *	26,7	20,0
10	MSVV 7232 - 010 - 0 *	29,2	22,5
11	MSVV 7232 - 011 - 0 *	31,7	25,0
12	MSVV 7232 - 012 - 0 *	34,2	27,5
13	MSVV 7232 - 013 - 0 *	36,7	30,0
14	MSVV 7232 - 014 - 0 *	39,2	32,5
15	MSVV 7232 - 015 - 0 *	41,7	35,0
16	MSVV 7232 - 016 - 0 *	44,2	37,5
17	MSVV 7232 - 017 - 0 *	46,7	40,0
18	MSVV 7232 - 018 - 0 *	49,2	42,5
19	MSVV 7232 - 019 - 0 *	51,7	45,0
20	MSVV 7232 - 020 - 0 *	54,2	47,5

- * Codierungen, Teilbestückungen im Rastermaß 5 mm und Sonderbestückungen auf Anfrage.
- * Polarizings, part assemblies in 5 mm spacing and special contact loading on request.

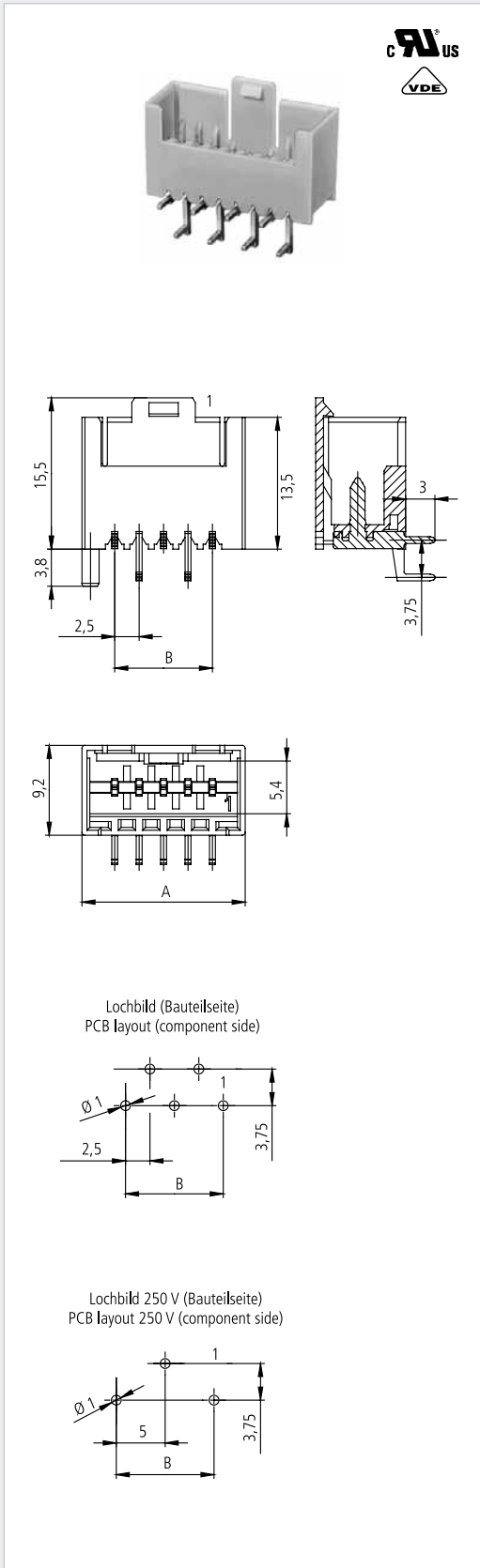

Serie MS 7246, ECO-TRONIC SMT

Stiftwannen für Serien MF 7234, 7260

Series MS 7246, ECO-TRONIC SMT

Pin connectors for series MF 7234, 7260

Serie MS 7246, nach RAST 2,5 für senkrechtes Stecken

Series MS 7246, to RAST 2.5 for vertical connections

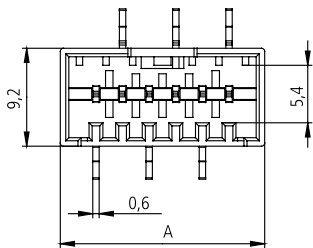
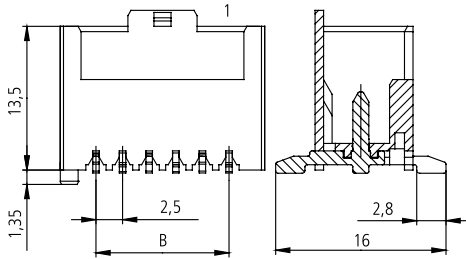

Lochbild
PCB layout

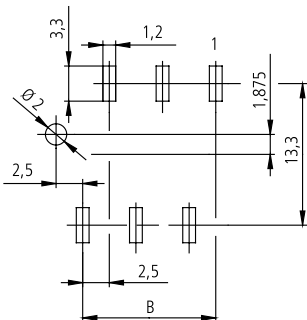

Polzahl Positions	Artikel-Nummer Part number	Abmessungen A Dimensions A	Abmessungen B Dimensions B	
3	MSVV 7246 - 003 - 0 *	11,7	5,0	
4	MSVV 7246 - 004 - 0 *	14,2	7,5	
5	MSVV 7246 - 005 - 0 *	16,7	10,0	
6	MSVV 7246 - 006 - 0 *	19,2	12,5	
7	MSVV 7246 - 007 - 0 *	21,7	15,0	
8	MSVV 7246 - 008 - 0 *	24,2	17,5	
9	MSVV 7246 - 009 - 0 *	26,7	20,0	
10	MSVV 7246 - 010 - 0 *	29,2	22,5	

- * Codierungen, Teilbestückungen im Rastermaß 5 mm und Sonderbestückungen auf Anfrage.
- * Polarizings, part assemblies in 5 mm spacing and special contact loading on request.

Serie MS 7247, ECO-TRONIC SMT

Stiftwannen für Serie MF 7234

Series MS 7247, ECO-TRONIC SMT

Pin connectors for series MF 7234

Serie MS 7247, nach RAST 2,5 für senkrecht Stecken

Series MS 7247, to RAST 2.5 for vertical connections

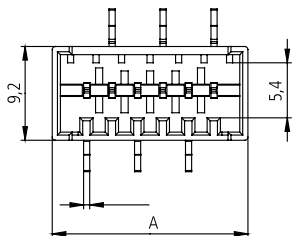
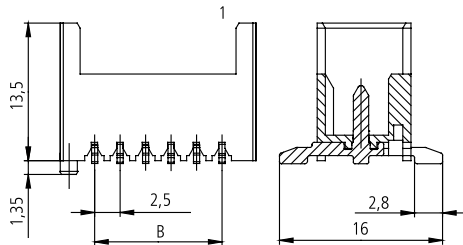

Lochbild
PCB layout

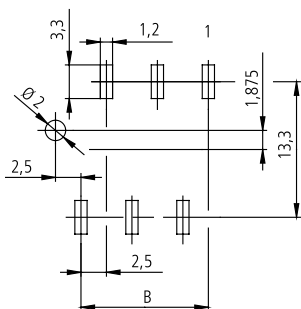

Polzahl Positions	Artikel-Nummer Part number	Abmessungen A Dimensions A	Abmessungen B Dimensions B	
3	MSVV 7247 - 003 - 0 *	11,7	5,0	
4	MSVV 7247 - 004 - 0 *	14,2	7,5	
5	MSVV 7247 - 005 - 0 *	16,7	10,0	
6	MSVV 7247 - 006 - 0 *	19,2	12,5	
7	MSVV 7247 - 007 - 0 *	21,7	15,0	
8	MSVV 7247 - 008 - 0 *	24,2	17,5	
9	MSVV 7247 - 009 - 0 *	26,7	20,0	
10	MSVV 7247 - 010 - 0 *	29,2	22,5	

- * Codierungen, Teilbestückungen im Rastermaß 5 mm und Sonderbestückungen auf Anfrage.
- * Polarizings, part assemblies in 5 mm spacing and special contact loading on request.

Serie MS 7250

Wannenriegel für Serien MF 7234, 7260

Series MS 7250

Pin connectors for series MF 7234, 7260

Serie MS 7250, nach RAST 2,5 für senkrechtes Stecken

Series MS 7250, to RAST 2.5 for vertical connections

Polzahl Positions	Artikel-Nummer Part number	Abmessungen A Dimensions A		
6	MSVV 7250 - 006 - 000	24,2		
6	MSVV 7250 - 006 - 001	24,2		
6	MSVV 7250 - 006 - 002	24,2		
10	MSVV 7250 - 010 - 000	39,2		
12	MSVV 7250 - 012 - 000	44,2		
19	MSVV 7250 - 019 - 000	66,7		
22	MSVV 7250 - 022 - 000	79,2		

Weitere Varianten auf Anfrage.
Other versions on request.

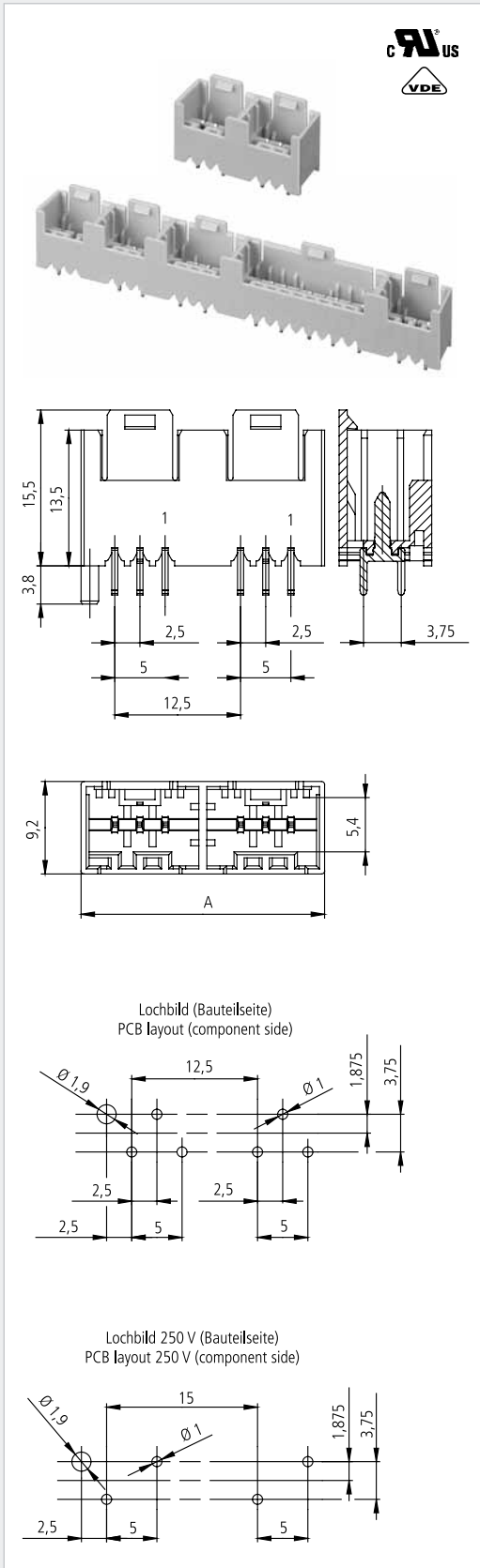

Serie MS 7320

Stiftwannen für Serien MF 7234, 7260

Series MS 7320

Pin connectors for series MF 7234, 7260

Serie MS 7320, für Einzelleiter

Series MS 7320 for discrete wire

Polzahl Positions	Artikel-Nummer Part number	Abmessungen A Dimensions A	Abmessungen B Dimensions B	Abmessung C Dimensions C
3	MSVV 7320 - 003 - 0 *	17,3	5,0	22,0
4	MSVV 7320 - 004 - 0 *	19,8	7,5	22,5
5	MSVV 7320 - 005 - 0 *	22,3	10,0	25,0
6	MSVV 7320 - 006 - 0 *	24,8	12,5	27,5
7	MSVV 7320 - 007 - 0 *	27,3	15,0	30,0
8	MSVV 7320 - 008 - 0 *	29,8	17,5	32,5
9	MSVV 7320 - 009 - 0 *	32,3	20,0	35,0
10	MSVV 7320 - 010 - 0 *	34,8	22,5	37,5
11	MSVV 7320 - 011 - 0 *	37,3	25,0	40,0
12	MSVV 7320 - 012 - 0 *	39,8	27,5	42,5

Leiterquerschnitt 0,22 - 0,35 mm².

* Codierungen, Teilbestückungen im Rastermaß 5 mm und Sonderbestückungen auf Anfrage.

Wire size 0.22 - 0.35 mm².

* Polarizings, part assemblies in 5 mm spacing and special contact loading on request.

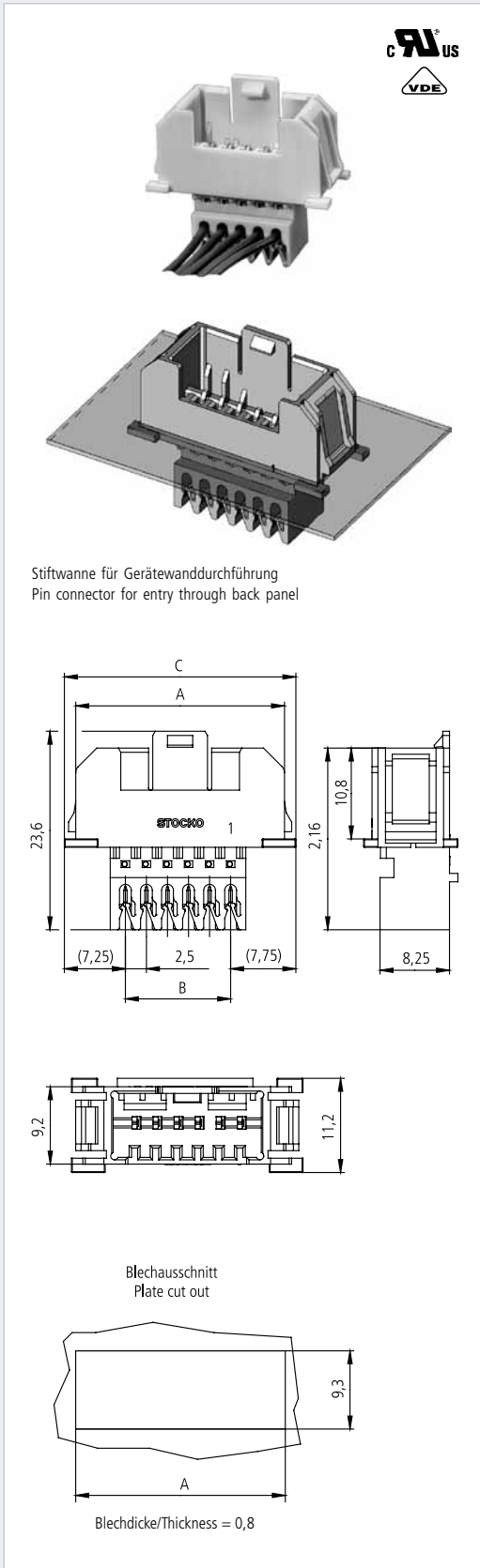

»Steckverbindersystem ECO-TRONIC pro«

Connector system ECO-TRONIC pro

Systembeschreibung

Federgehäuse

- Direkt- und Indirektsteckverbinder mit Schneidklemmanschluß in Anlehnung an die Weißgeräte-Spezifikation RAST 2,5
- Große Luft- und Kriechstrecken durch geschlossene Kabelschächte
- Hohe Anzahl unverwechselbarer Stecker durch Codierstiftschneiden
- Als Direktstecker erfolgen Codierung und Verrastung auf der Platine

Stiftwannen

- Ausführung in vertikaler oder horizontaler Steckrichtung zur Leiterplatte

Description of system

IDC housings

- Direct and indirect connectors with IDC termination in accordance with the RAST 2.5 standard specification for domestic appliances
- Closed cable entries ensure long air and creepage distances
- Trimming polarizing pegs to individual requirements produces a large number of clearly defined connector combinations
- With direct edge versions, polarizing and locking feature for PCB

Pin connectors

- Versions for vertical or horizontal PC board assembly

Bestellbeispiel

Stiftwanne, 3polig, uncodiert, vollbestückt für senkrechtes Stecken

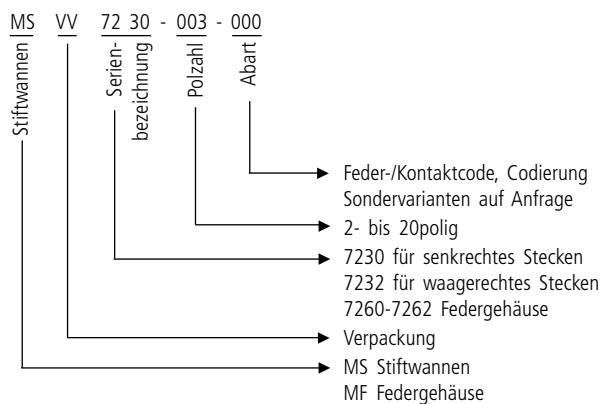

Example for ordering

3-way pin connector, unpolarized, fully assembled for vertical connections

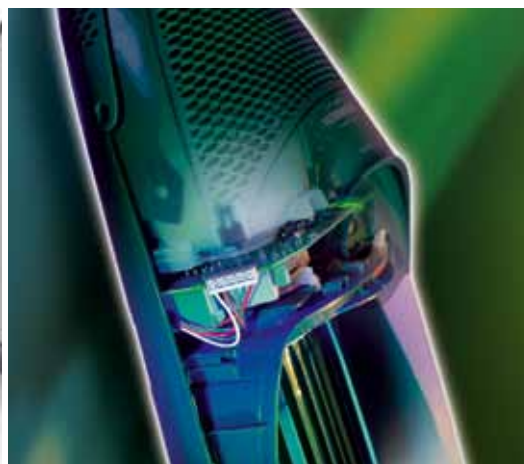
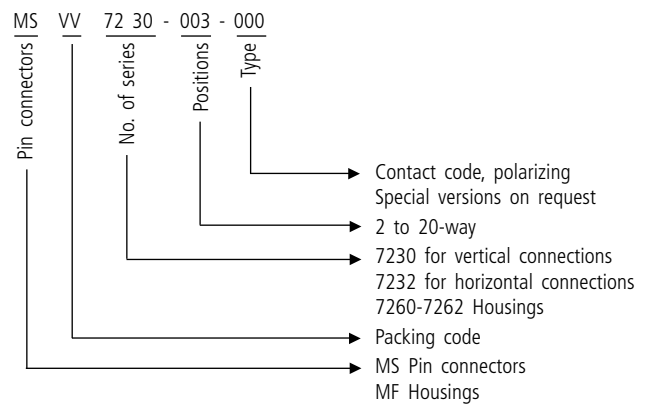



Technische Daten

Mechanisch

Raster	5 mm
Polzahl	2 - 10
Anschlußart	Schneidklemmtechnik
Leiterquerschnitt	0,35 - 0,75 mm ²
Isolations Ø	max. 2,4 mm
Isolationshärte	Shore A 90° ± 5
Leiteraufbau	Litze
Temperaturbereich	-40°C ...+ 120°C
Leiterplattendicke	1,55 ± 0,19 mm

Elektrisch

Bemessungsstrom	6 A
Bemessungsspannung	250 V
Durchschlagfestigkeit Gehäusematerial	2,8 kV
Isolationswiderstand	> 10 ⁹ Ω
Durchgangswiderstand	< 10 m Ω
Luft- und Kriechstrecken	> 3,2 mm
Kriechstromfestigkeit	CTI ≥ 400
Freigaben	DIN EN 61984 (IEC 61984) UL / ULC E96569

Werkstoffe

Kontakt	Feder: CuSn Cu-Legierung Stift: CuZn
Kontaktoberfläche	Feder: Sn Stift: NiSn
Isolierkörper	PA, glühdrahtbeständig, GWT 750°C nach IEC 60335-1
Gehäusefarbe	natur
Codierung	nach RAST 2,5

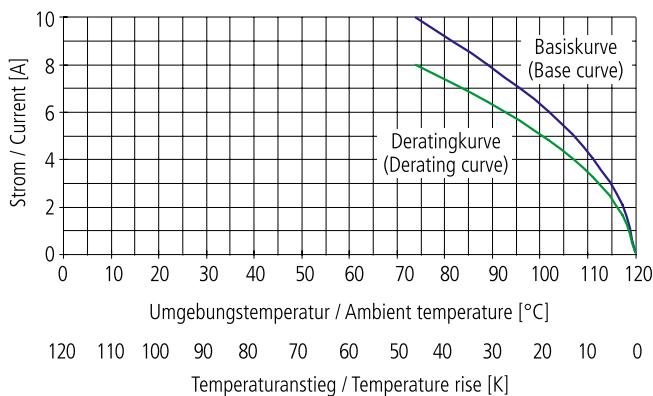

Technical data

Mechanical

Pitch	5 mm
Positions	2 - 10
Termination	IDC
Wire size	0.35 - 0.75 mm ²
Insulation Ø	max. 2.4 mm
Hardness of insulation	Shore A 90° ± 5
Type of wire	stranded
Temperature range	-40°C ...+ 120°C
Board thickness	1.55 ± 0.19 mm

Electrical

Current rating	6 A
Nom. voltage	250 V
Dielectrical strength	2.8 kV
Insulation resistance	> 10 ⁹ Ω
Contact resistance	< 10 m Ω
Air gap and creeping distances	> 3.2 mm
Tracking resistance	CTI ≥ 400
Approved by	DIN EN 61984 (IEC 61984) UL / ULC E96569

Materials

Contact	Socket: CuSn Cu-alloy Pin: CuZn
Contact finishing	Socket: Sn Pin: NiSn
Housing	PA, glow wire resistant, GWT 750°C acc. to IEC 60335-1
Colour of housing	natural
Polarizing	to RAST 2.5

Derating-Kurve / Derating curve

Leiterquerschnitt: 0,75 mm² / 10-poliger Stecker / Direktsteckung
Wire size: 0.75 mm² / 10-way connector / on PCB



Serie MF 7260

Federgehäuse in Schneidklemmtechnik

Series MF 7260

IDC housings

Serie MF 7260 für Einzelleiter zum direkten und indirekten Stecken Series MF 7260 for discrete wire for direct and indirect connections

Polzahl Positions	Artikel-Nummer Part number	Abmessungen A Dimensions A	Abmessungen B Dimensions B
2	MFV 7260 - 002 - *	10	5
3	MFV 7260 - 003 - *	15	10
4	MFV 7260 - 004 - *	20	15
5	MFV 7260 - 005 - *	25	20
6	MFV 7260 - 006 - *	30	25
7	MFV 7260 - 007 - *	35	30
8	MFV 7260 - 008 - *	40	35
9	MFV 7260 - 009 - *	45	40
10	MFV 7260 - 010 - *	50	45



Darstellung vormontiert
Designation pre-assembled

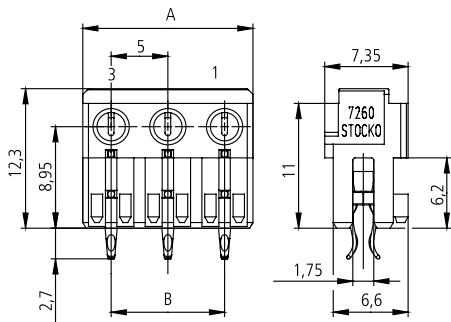

Darstellung ohne Kontakte
Designation without contacts

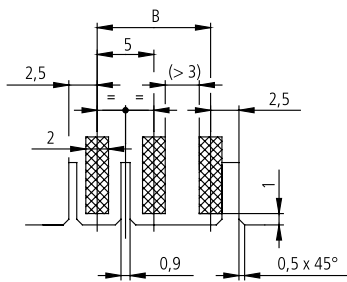
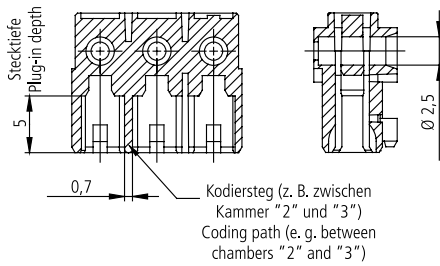

- * Vorzugstypen siehe Seite 98. Codierungen, Teilbestückungen im Rastermaß 5 mm und Sonderbestückungen auf Anfrage
- * Preferential types see page 98. Polarizings, part assemblies in 5 mm spacing, special contact loading on request

Serie MF 7262

Federgehäuse in Schneidklemmtechnik

Series MF 7262

IDC housings

Serie MF 7262 für Einzelleiter zum direkten Stecken, mit PCB-Verrastung Series MF 7262 for discrete wire for direct connections, with PCB locking

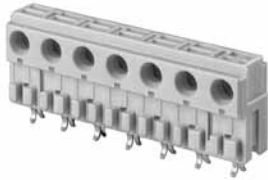

Darstellung vormontiert
Designation pre-assembled

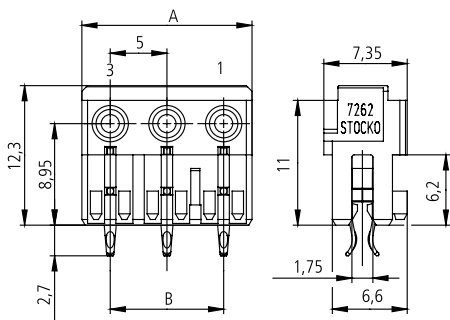

Darstellung ohne Kontakte
Designation without contacts

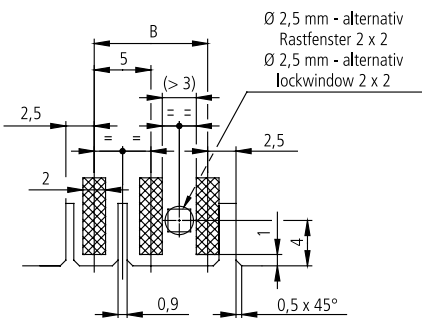
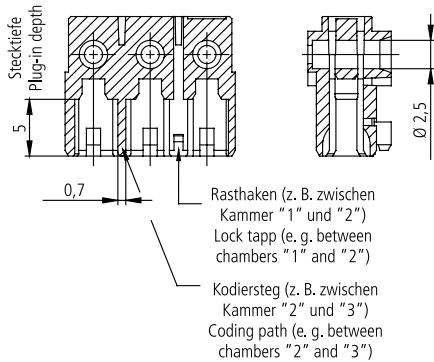

Polzahl Positions	Artikel-Nummer Part number	Abmessungen A Dimensions A	Abmessungen B Dimensions B
2	MFVV 7262 - 002 - *	10	5
3	MFVV 7262 - 003 - *	15	10
4	MFVV 7262 - 004 - *	20	15
5	MFVV 7262 - 005 - *	25	20
6	MFVV 7262 - 006 - *	30	25
7	MFVV 7262 - 007 - *	35	30
8	MFVV 7262 - 008 - *	40	35
9	MFVV 7262 - 009 - *	45	40
10	MFVV 7262 - 010 - *	50	45

- * Vorzugstypen siehe Seite 99. Codierungen, Teilbestückungen im Rastermaß 5 mm und Sonderbestückungen auf Anfrage
- * Preferential types see page 99. Polarizings, part assemblies in 5 mm spacing, special contact loading on request

Serie MS 7230

Stiftwannen für Serie MF 7260

Series MS 7230

Pin connectors for series MF 7260

Serie MS 7230, nach RAST 2,5 für senkrecht Stecken, teilbestückt im Raster 5 mm

Series MS 7230, to RAST 2.5 for vertical connections, partially assembled in 5 mm spacing

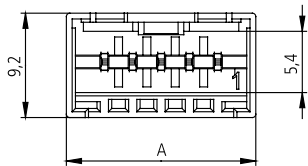
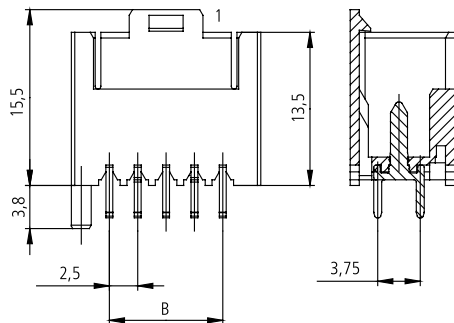

Lochbild standard (Bauteilseite)
PCB layout standard (component side)

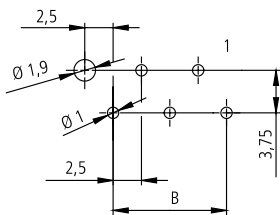

Lochbild 250 V (Bauteilseite)
PCB layout 250 V (component side)

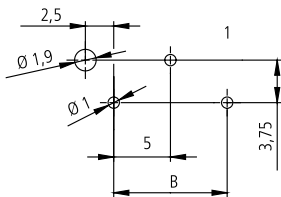

Polzahl Positions	Artikel-Nummer Part number	Abmessungen A Dimensions A	Abmessungen B Dimensions B
2	MSVV 7230 - 003 - *	11,7	5,0
3	MSVV 7230 - 005 - *	16,7	10,0
4	MSVV 7230 - 007 - *	21,7	15,0
5	MSVV 7230 - 009 - *	26,7	20,0
6	MSVV 7230 - 011 - *	31,7	25,0
7	MSVV 7230 - 013 - *	36,7	30,0
8	MSVV 7230 - 015 - *	41,7	35,0
9	MSVV 7230 - 017 - *	46,7	40,0
10	MSVV 7230 - 019 - *	51,7	45,0

- * Codierungen und Sonderbestückungen auf Anfrage.
- * Polarizings and special contact loading on request.

Serie MS 7232

Stiftwannen für Serie MF 7260

Series MS 7232

Pin connectors for series MF 7260

Serie MS 7232, nach RAST 2,5 für waagerechtes Stecken, teilbestückt im Raster 5 mm

Series MS 7232, to RAST 2.5 for horizontal connections, partially assembled in 5 mm spacing

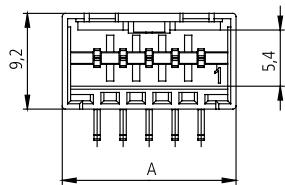
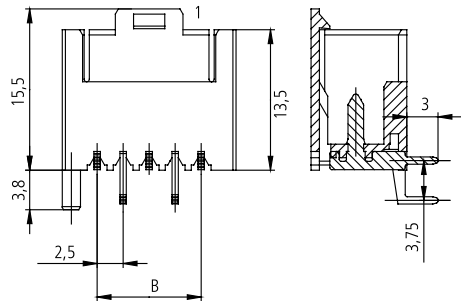

Lochbild (Bauteilseite)
PCB layout (component side)

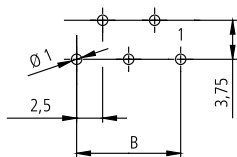

Lochbild 250 V (Bauteilseite)
PCB layout 250 V (component side)

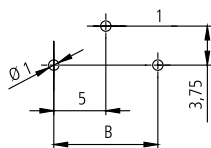

Polzahl Positions	Artikel-Nummer Part number	Abmessungen A Dimensions A	Abmessungen B Dimensions B	
2	MSVV 7232 - 003 - *	11,7	5,0	
3	MSVV 7232 - 005 - *	16,7	10,0	
4	MSVV 7232 - 007 - *	21,7	15,0	
5	MSVV 7232 - 009 - *	26,7	20,0	
6	MSVV 7232 - 011 - *	31,7	25,0	
7	MSVV 7232 - 013 - *	36,7	30,0	
8	MSVV 7232 - 015 - *	41,7	35,0	
9	MSVV 7232 - 017 - *	46,7	40,0	
10	MSVV 7232 - 019 - *	51,7	45,0	

- * Codierungen und Sonderbestückungen auf Anfrage.
- * Polarizings and special contact loading on request.

»Steckverbindersystem TL 1« Connector system TL 1

Systembeschreibung

Federgehäuse

- Direkt- und Indirektsteckverbinder mit Schneidklemmanschluß
- Die Blattfederkontakte gewährleisten auch bei hochpoligen Verbindungen ein problemloses Stecken
- Die Verarbeitung erfolgt mit Handzangen oder Halbautomaten

Stiftwannen

- Ausführung in vertikaler oder horizontaler Steckrichtung zur Leiterplatte

Description of system

IDC housings

- Direct and indirect connectors with IDC termination
- The leaf spring contacts ensure trouble-free connections even in large multi-way systems
- Suitable for termination with hand tools, or on semi automated machines

Pin connectors

- Versions for vertical or horizontal PC board assembly

Bestellbeispiel

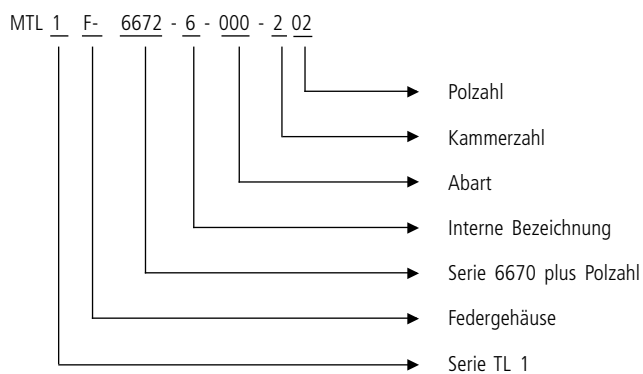

Example for ordering

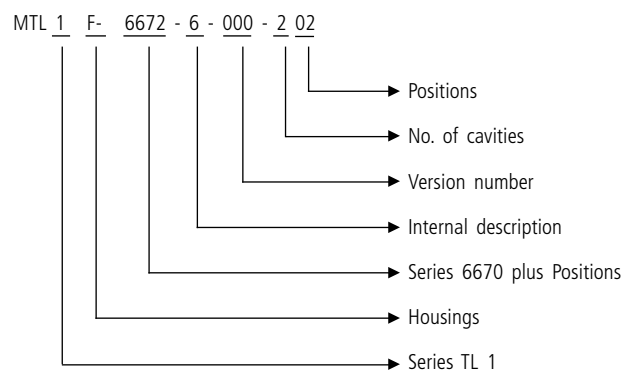



Technische Daten

Mechanisch

Raster	5 mm
Polzahl	2 - 12
Anschlußart	Schneidklemmtechnik
Leiterquerschnitt	0,5 / 0,75 mm ²
Isolations Ø	max. 2,5 mm
Isolationshärte	Shore A 90° ± 5
Leiteraufbau	Massiv, Litze
Temperaturbereich	-40 °C ... + 110 °C
Leiterplattendicke	1,6 ± 0,14 mm

Elektrisch

Bemessungsstrom	6 A
Durchschlagfestigkeit	
Gehäusematerial	> 3,0 kV
Isolationswiderstand	> 10 ⁹ Ω
Durchgangswiderstand	< 5 m Ω
Luft- und Kriechstrecke	> 3 mm
Kriechstromfestigkeit	CTI ≥ 250
Bemessungsspannung	250 V
Freigaben	DIN EN 61984 (IEC 61984) UL / ULC E96569

Werkstoffe

Kontakt	Feder: CuSn Stift: CuZn
Kontaktoberfläche	Feder: Sn Stift: NiSn
Isolierkörper	PBT
Gehäusefarbe	natur

Technical data

Mechanical

Pitch	5 mm
Positions	2 - 12
Termination	IDC
Wire size	0.5 / 0.75 mm ²
Insulation Ø	max. 2.5 mm
Hardness of insulation	Shore A 90° ± 5
Type of wire	solid, stranded
Temperature range	-40 °C ... + 110 °C
Board thickness	1.6 ± 0.14 mm

Electrical

Current rating	6 A
Dielectrical strength	> 3.0 kV
Insulation resistance	> 10 ⁹ Ω
Contact resistance	< 5 m Ω
Air gap and creeping distance	> 3 mm
Tracking resistance	CTI ≥ 250
Nom. voltage	250 V
Approved by	DIN EN 61984 (IEC 61984) UL / ULC E96569

Materials

Contact	Socket: CuSn Pin: CuZn
Contact finishing	Socket: Sn Pin: NiSn
Housing	PBT
Colour of housing	natural

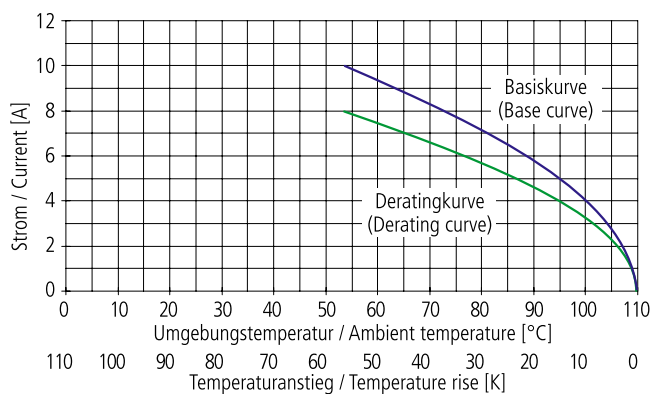

Derating-Kurve / Derating curve

Leiterquerschnitt: 0,75 mm² / 12-poliger Stecker
Wire size: 0.75 mm² / 12-way connector



Serie MTL 1 F 6670

Federgehäuse in Schneidklemmtechnik

Series MTL 1 F 6670

IDC housings

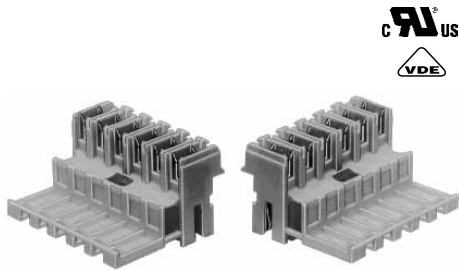

Darstellung endmontiert
Designation final-assembled

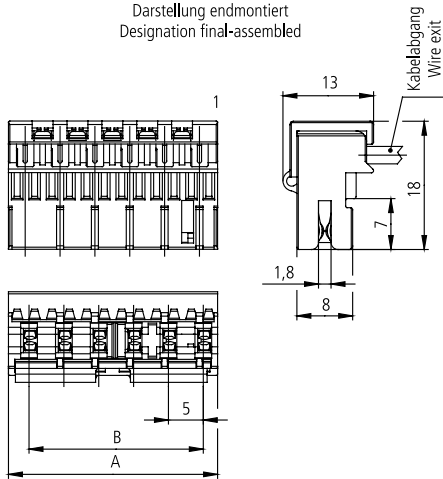

Darstellung endmontiert
Designation final-assembled

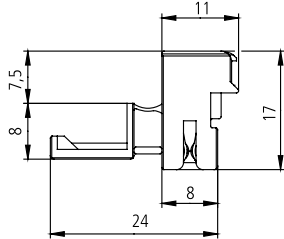

Div. Rastfenster möglich
Div. lock windows possible

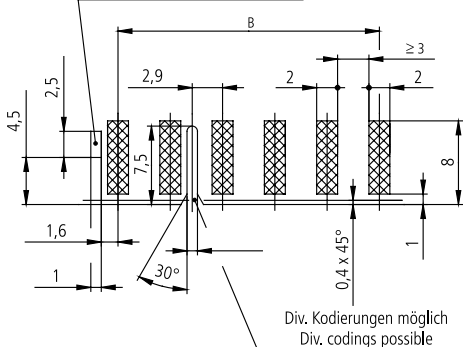

Serie MTL 1 F 6670, seitlich versetzte Mittencodierung und Rastnocken Series MTL 1 F 6670, offset polarizing and locking features

Polzahl Positions	Artikel-Nummer Part number	Codierung zw. Kammer Polarizing between cavities nos.	Verrastung zw. Kammer Locking between cavities nos.
2	MTL 1 F 6672 - 6 - 000 - 202	-	-
2	MTL 1 F 6672 - 6 - 001 - 202	-	1 + 2
2	MTL 1 F 6672 - 6 - 002 - 202	1 + 2	1 + 2
3	MTL 1 F 6673 - 6 - 000 - 303	1 + 2	-
3	MTL 1 F 6673 - 6 - 001 - 303	1 + 2	1 + 2
3	MTL 1 F 6673 - 6 - 003 - 303	1 + 2	2 + 3
3	MTL 1 F 6673 - 6 - 004 - 303	2 + 3	-
4	MTL 1 F 6674 - 6 - 000 - 404	1 + 2	-
4	MTL 1 F 6674 - 6 - 001 - 404	1 + 2	1 + 2 / 3 + 4
4	MTL 1 F 6674 - 6 - 002 - 404	3 + 4	1 + 2 / 3 + 4
4	MTL 1 F 6674 - 6 - 005 - 404	2 + 3	-
5	MTL 1 F 6675 - 6 - 000 - 505	2 + 3	-
6	MTL 1 F 6676 - 6 - 000 - 606	4 + 5	1 + 2 / 5 + 6
7	MTL 1 F 6677 - 6 - 000 - 707	3 + 4	1 + 2 / 6 + 7
8	MTL 1 F 6678 - 6 - 000 - 808	3 + 4	1 + 2 / 7 + 8
9	MTL 1 F 6679 - 6 - 000 - 909	4 + 5	1 + 2 / 8 + 9
10	MTL 1 F 6680 - 6 - 000 - 1010	4 + 5	1 + 2 / 9 + 10
11	MTL 1 F 6681 - 6 - 000 - 1111	5 + 6	1 + 2 / 10 + 11
12	MTL 1 F 6682 - 6 - 000 - 1212	5 + 6	1 + 2 / 11 + 12

Polzahl Positions	Artikel-Nummer Part number	Abmessung A Dimensions A	Abmessung B Dimensions B
2	MTL 1 F 6672 - 6 - * - 202	10	5
3	MTL 1 F 6673 - 6 - * - 303	15	10
4	MTL 1 F 6674 - 6 - * - 404	20	15
5	MTL 1 F 6675 - 6 - * - 505	25	20
6	MTL 1 F 6676 - 6 - * - 606	30	25
7	MTL 1 F 6677 - 6 - * - 707	35	30
8	MTL 1 F 6678 - 6 - * - 808	40	35
9	MTL 1 F 6679 - 6 - * - 909	45	40
10	MTL 1 F 6680 - 6 - * - 1010	50	45
11	MTL 1 F 6681 - 6 - * - 1111	55	50
12	MTL 1 F 6682 - 6 - * - 1212	60	55

- * Die Abmessungen der jeweiligen Polzahl sind für alle Codierungen gleich.
- * Dimensions in each number of positions are the same, regardless of the polarizing type.

Weitere Codierungen und Verrastungen sowie Sondertypen für Leiterquerschnitte $\leq 0,5 \text{ mm}^2$ auf Anfrage.
Further polarizings and locking features as well as special types for wire sizes $\leq 0.5 \text{ mm}^2$ on request.

Serie MTL 1 F 6690

Federgehäuse in Schneidklemmtechnik

Series MTL 1 F 6690

IDC housings

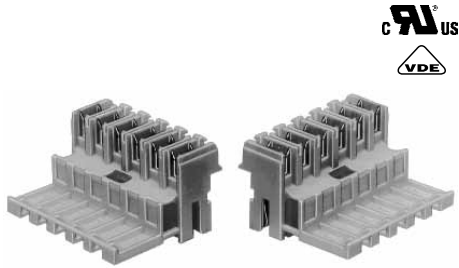

Darstellung endmontiert
Designation final-assembled

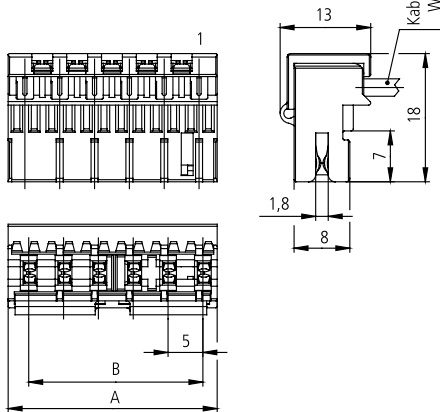

Darstellung endmontiert
Designation final-assembled

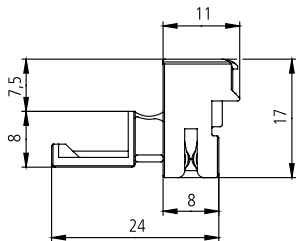

Ø 2,5 mm - alternativ
Rastfenster 2 x 2
Ø 2,5 mm - alternativ
lock window 2 x 2

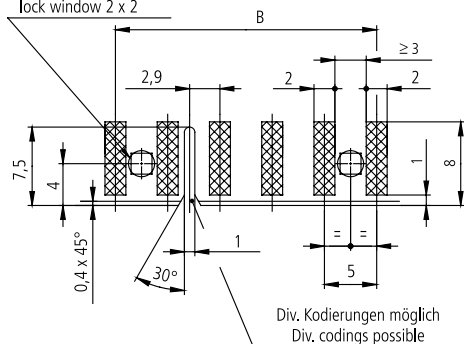

Div. Codierungen möglich
Div. codings possible

Serie MTL 1 F 6690, Mittencodierung und Rastnocken

Series MTL 1 F 6690, central polarizing and locking features

Polzahl Positions	Artikel-Nummer Part number	Codierung zw. Kammer Polarizing between cavities nos.	Verrastung zw. Kammer Locking between cavities nos.
2	MTL 1 F 6692 - 6 - 000 - 202	-	1 + 2
2	MTL 1 F 6692 - 6 - 005 - 202	1 + 2	-
3	MTL 1 F 6693 - 6 - 000 - 303	1 + 2	2 + 3
3	MTL 1 F 6693 - 6 - 001 - 303	2 + 3	1 + 2
3	MTL 1 F 6693 - 6 - 002 - 303	-	2 + 3
3	MTL 1 F 6693 - 6 - 004 - 303	1 + 2	-
4	MTL 1 F 6694 - 6 - 000 - 404	-	1 + 2 / 3 + 4
4	MTL 1 F 6694 - 6 - 004 - 404	1 + 2	-
4	MTL 1 F 6694 - 6 - 006 - 404	2 + 3	-
5	MTL 1 F 6695 - 6 - 000 - 505	2 + 3	1 + 2 / 4 + 5
5	MTL 1 F 6695 - 6 - 001 - 505	3 + 4	1 + 2 / 4 + 5
5	MTL 1 F 6695 - 6 - 002 - 505	-	1 + 2 / 4 + 5
6	MTL 1 F 6696 - 6 - 000 - 606	2 + 3	1 + 2 / 5 + 6
6	MTL 1 F 6696 - 6 - 001 - 606	4 + 5	1 + 2 / 5 + 6
6	MTL 1 F 6696 - 6 - 002 - 606	-	1 + 2 / 5 + 6
7	MTL 1 F 6697 - 6 - 000 - 707	3 + 4	1 + 2 / 6 + 7
8	MTL 1 F 6698 - 6 - 000 - 808	3 + 4	1 + 2 / 7 + 8
9	MTL 1 F 6699 - 6 - 000 - 909	3 + 4	1 + 2 / 8 + 9
10	MTL 1 F 6700 - 6 - 000 - 1010	3 + 4	1 + 2 / 9 + 10
11	MTL 1 F 6701 - 6 - 000 - 1111	3 + 4	1 + 2 / 10 + 11
12	MTL 1 F 6702 - 6 - 000 - 1212	3 + 4	1 + 2 / 11 + 12

Polzahl Positions	Artikel-Nummer Part number	Abmessungen A Dimensions A	Abmessungen B Dimensions B
2	MTL 1 F 6692 - 6 - * - 202	10	5
3	MTL 1 F 6693 - 6 - * - 303	15	10
4	MTL 1 F 6694 - 6 - * - 404	20	15
5	MTL 1 F 6695 - 6 - * - 505	25	20
6	MTL 1 F 6696 - 6 - * - 606	30	25
7	MTL 1 F 6697 - 6 - * - 707	35	30
8	MTL 1 F 6698 - 6 - * - 808	40	35
9	MTL 1 F 6699 - 6 - * - 909	45	40
10	MTL 1 F 6700 - 6 - * - 1010	50	45
11	MTL 1 F 6701 - 6 - * - 1111	55	50
12	MTL 1 F 6702 - 6 - * - 1212	60	55

- * Die Abmessungen der jeweiligen Polzahl sind für alle Codierungen gleich.
- * Dimensions in each number of positions are the same, regardless of the polarizing type.

Weitere Codierungen und Verrastungen sowie Sondertypen für Leiterquerschnitte $\leq 0,5 \text{ mm}^2$ auf Anfrage.
Further polarizings and locking features as well as special types for wire sizes $\leq 0,5 \text{ mm}^2$ on request

Serie MTL 1 F 6710

Federgehäuse in Schneidklemmtechnik

Series MTL 1 F 6710

IDC housings

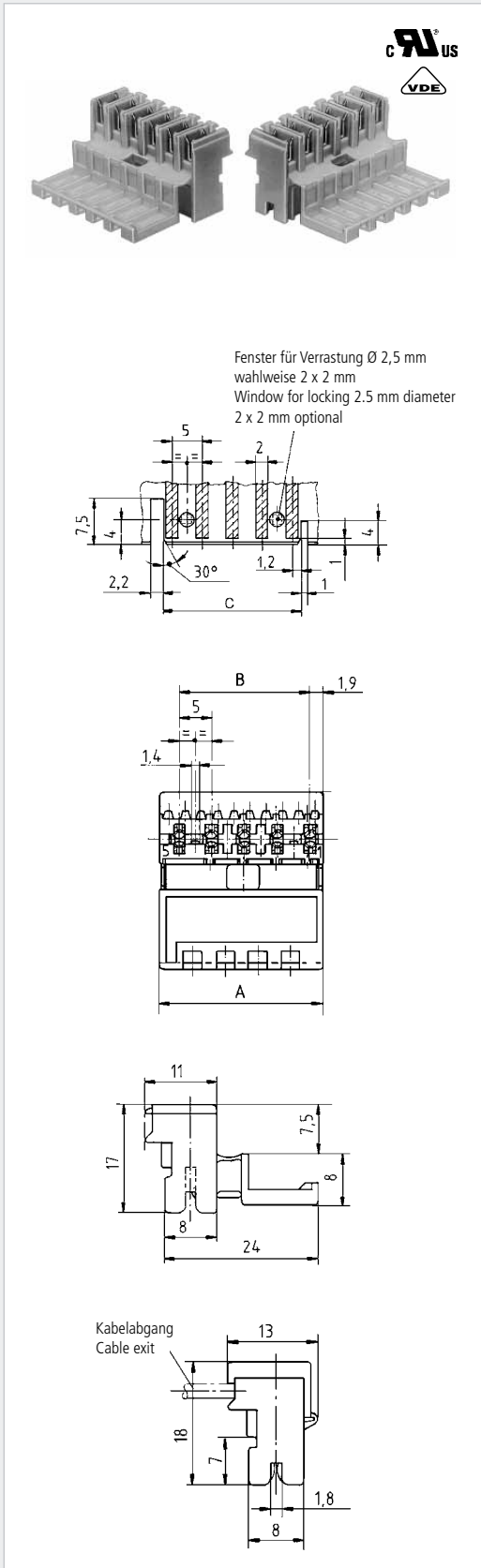

Serie MTL 1 F 6710, Mittencodierung, seitliche Codierstege und Rastnocken

Series MTL 1 F 6710, central polarizing, polarizing pegs at sides and locking features

Polzahl Positions	Artikel-Nummer Part number	Codierung zw. Kammer Polarizing between cavities nos.	Verrastung zw. Kammer Locking between cavities nos.
2	MTL 1 F 6712 - 6 - 000 - 202	-	-
2	MTL 1 F 6712 - 6 - 001 - 202	-	1 + 2
2	MTL 1 F 6712 - 6 - 002 - 202	1 + 2	-
3	MTL 1 F 6713 - 6 - 000 - 303	-	-
3	MTL 1 F 6713 - 6 - 001 - 303	-	1 + 2
3	MTL 1 F 6713 - 6 - 003 - 303	2 + 3	-
3	MTL 1 F 6713 - 6 - 004 - 303	1 + 2	-
4	MTL 1 F 6714 - 6 - 000 - 404	-	-
4	MTL 1 F 6714 - 6 - 001 - 404	-	1 + 2 / 3 + 4
4	MTL 1 F 6714 - 6 - 002 - 404	2 + 3	1 + 2 / 3 + 4
5	MTL 1 F 6715 - 6 - 000 - 505	-	1 + 2 / 4 + 5
5	MTL 1 F 6715 - 6 - 002 - 505	2 + 3	1 + 2 / 4 + 5
6	MTL 1 F 6716 - 6 - 000 - 606	-	1 + 2 / 5 + 6
6	MTL 1 F 6716 - 6 - 002 - 606	2 + 3	1 + 2 / 5 + 6
7	MTL 1 F 6717 - 6 - 000 - 707	-	1 + 2 / 6 + 7
7	MTL 1 F 6717 - 6 - 002 - 707	2 + 3	1 + 2 / 6 + 7
8	MTL 1 F 6718 - 6 - 000 - 808	-	1 + 2 / 7 + 8
8	MTL 1 F 6718 - 6 - 001 - 808	2 + 3	1 + 2 / 7 + 8
9	MTL 1 F 6719 - 6 - 000 - 909	-	1 + 2 / 8 + 9
10	MTL 1 F 6720 - 6 - 000 - 1010	-	1 + 2 / 9 + 10
11	MTL 1 F 6721 - 6 - 000 - 1111	-	1 + 2 / 10 + 11
12	MTL 1 F 6722 - 6 - 000 - 1212	-	1 + 2 / 11 + 12

Polzahl Positions	Artikel-Nummer Part number	Abmessungen A Dimensions A	Abmessungen B Dimensions B	Abmessungen C Dimensions C
2	MTL 1 F 6712 - 6 - * - 202	10	5	7,3
3	MTL 1 F 6713 - 6 - * - 303	15	10	12,3
4	MTL 1 F 6714 - 6 - * - 404	20	15	17,3
5	MTL 1 F 6715 - 6 - * - 505	25	20	22,3
6	MTL 1 F 6716 - 6 - * - 606	30	25	27,3
7	MTL 1 F 6717 - 6 - * - 707	35	30	32,3
8	MTL 1 F 6718 - 6 - * - 808	40	35	37,3
9	MTL 1 F 6719 - 6 - * - 909	45	40	42,3
10	MTL 1 F 6720 - 6 - * - 1010	50	45	47,3
11	MTL 1 F 6721 - 6 - * - 1111	55	50	52,3
12	MTL 1 F 6722 - 6 - * - 1212	60	55	57,3

- * Die Abmessungen der jeweiligen Polzahl sind für alle Codierungen gleich.
- * Dimensions in each number of positions are the same, regardless of the polarizing type.

Weitere Codierungen und Verrastungen sowie Sondertypen für Leiterquerschnitte $\leq 0,5 \text{ mm}^2$ auf Anfrage.
Further polarizings and locking features as well as special types for wire sizes $\leq 0.5 \text{ mm}^2$ on request.

Serie MTL 1 H 485

Kupplungsgehäuse für Serie MTL 1 F 6710

Series MTL 1 H 485

Flying lead connector housing for MTL 1 F 6710

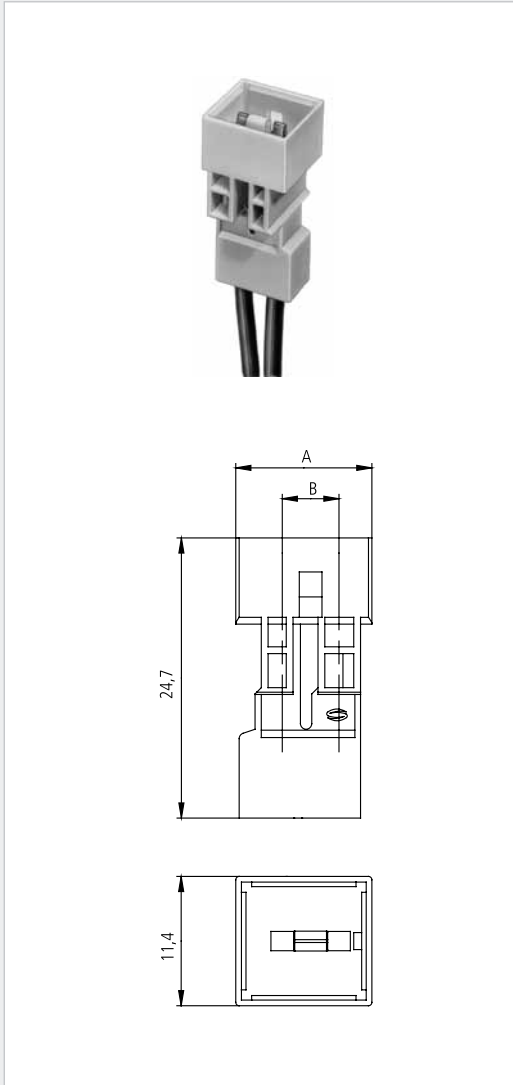

Serie MTL 1 H 485 für lose Kupplungen Series MTL 1 H 485 for flying leads

Polzahl Positions	Artikel-Nummer Part number	Abmessungen A Dimensions A	Abmessungen B Dimensions B	
2	MTL 1 H 485-1-0-200	12	5	

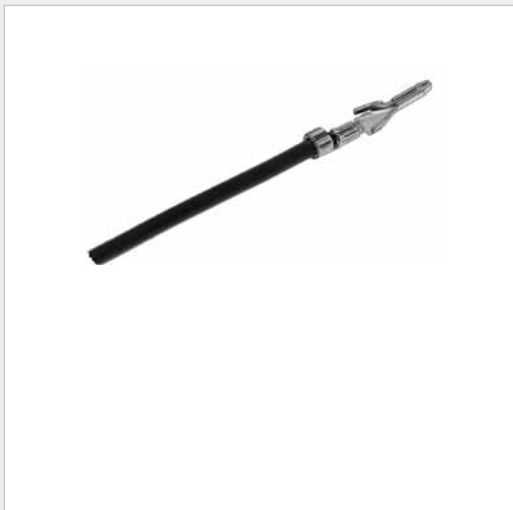

Kontakte Contacts

Artikel-Nummer Part number	Leiterquerschnitt Wire size	Material Material	Oberfläche Finishing
RSB 8095 V 1,5-1,5	0,5-1,5 mm ²	CuSn	verzinkt / tin plated

Isolations Ø 1,8 - 2,8 mm
Insulation Ø 1.8 - 2.8 mm

Serie MTL 1 S 8180

Stiftwannen für Serie MTL 1 F 6690

Series MTL 1 S 8180

Pin connectors for series MTL 1 F 6690

Serie MTL 1 S 8180 für senkrechtes Stecken Series MTL 1 S 8180 for vertical connections

Polzahl Positions	Artikel-Nummer Part number	Abmessungen A Dimensions A	Abmessungen B Dimensions B
2	MTL 1 S 8182 - 6 - * - 202	12	5
3	MTL 1 S 8183 - 6 - * - 303	17	10
4	MTL 1 S 8184 - 6 - * - 404	20	15
5	MTL 1 S 8185 - 6 - * - 505	25	20
6	MTL 1 S 8186 - 6 - * - 606	30	25
7	MTL 1 S 8187 - 6 - * - 707	35	30
8	MTL 1 S 8188 - 6 - * - 808	40	35
9	MTL 1 S 8189 - 6 - * - 909	45	40
10	MTL 1 S 8190 - 6 - * - 1010	50	45
11	MTL 1 S 8191 - 6 - * - 1111	55	50
12	MTL 1 S 8192 - 6 - * - 1212	60	55

- * Codierungen und Sonderbestückungen auf Anfrage.
- * Polarizings and special contact loading on request.

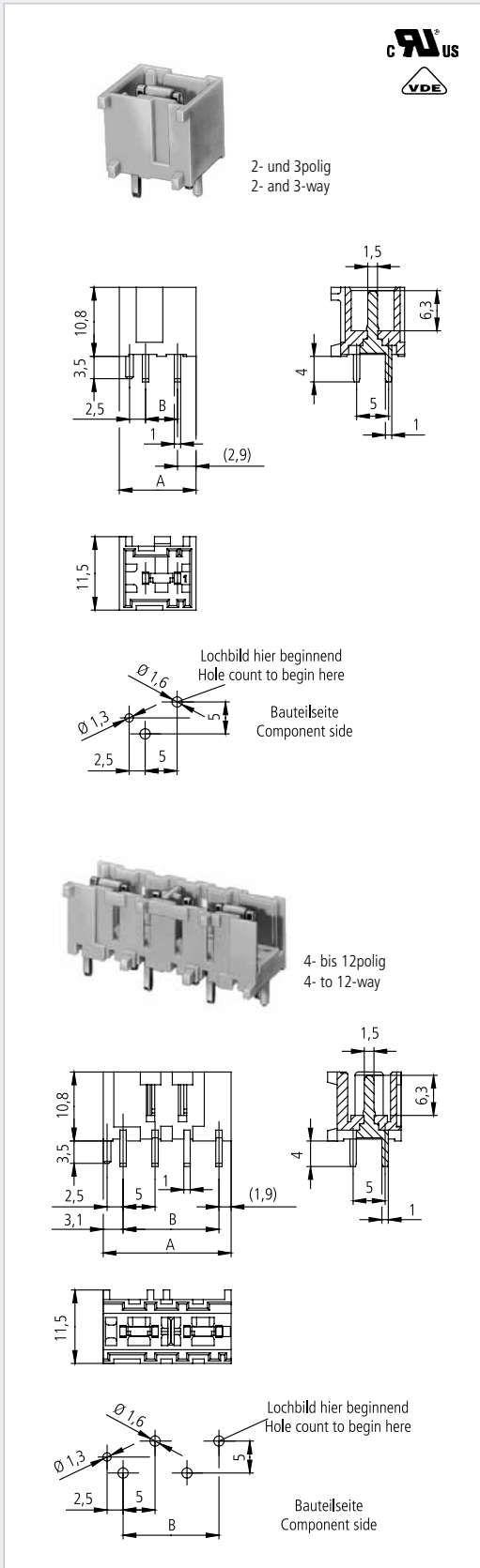

Serie MTL 1 S 8200

Stiftwannen für Serie MTL 1 F 6690

Series MTL 1 S 8200

Pin connectors for series MTL 1 F 6690

Serie MTL 1 S 8200 für waagerechtes Stecken Series MTL 1 S 8200 for horizontal connections

Polzahl Positions	Artikel-Nummer Part number	Abmessungen A Dimensions A	Abmessungen B Dimensions B	Abmessungen C Dimensions C
2	MTL 1 S 8202 - 6 - * - 202	12	5	2,5
3	MTL 1 S 8203 - 6 - * - 303	17	10	5,0
4	MTL 1 S 8204 - 6 - * - 404	20	15	8,2
5	MTL 1 S 8205 - 6 - * - 505	25	20	10,7
6	MTL 1 S 8206 - 6 - * - 606	30	25	13,2
7	MTL 1 S 8207 - 6 - * - 707	35	30	15,7
8	MTL 1 S 8208 - 6 - * - 808	40	35	18,2
9	MTL 1 S 8209 - 6 - * - 909	45	40	20,7
10	MTL 1 S 8210 - 6 - * - 1010	50	45	10,7 / 35,7
11	MTL 1 S 8211 - 6 - * - 1111	55	50	10,7 / 40,7
12	MTL 1 S 8212 - 6 - * - 1212	60	55	10,7 / 45,7

- * Codierungen und Sonderbestückungen auf Anfrage.
- * Polarizings and special contact loading on request.

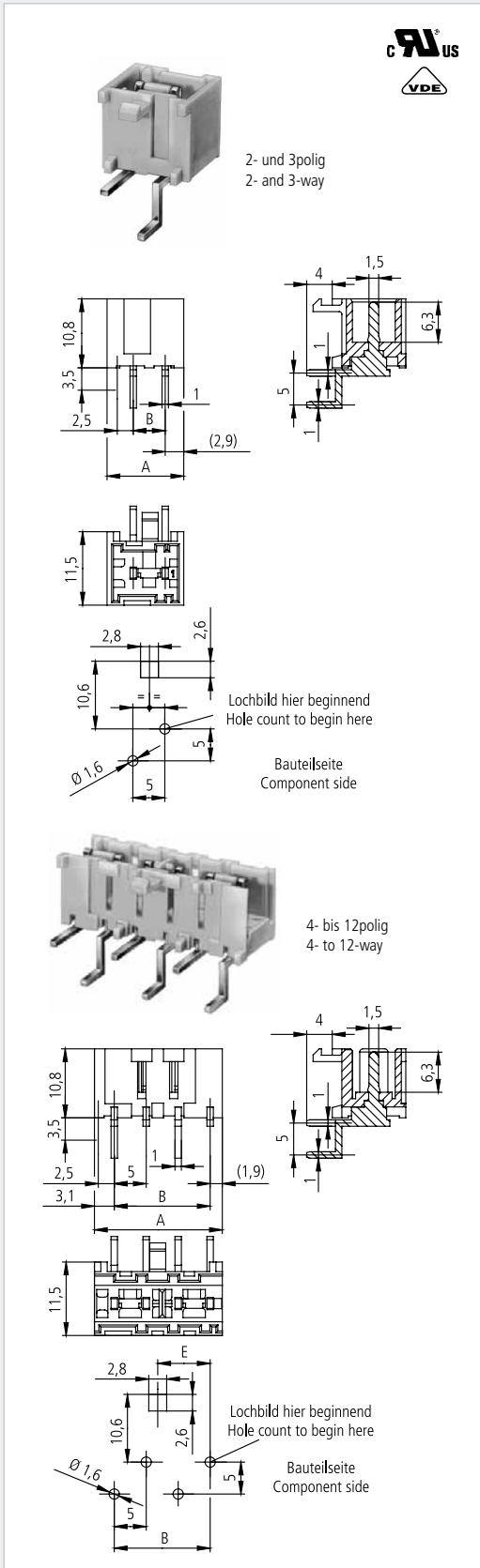

»Steckverbindersystem ECO-DOMO«

Connector system ECO-DOMO

Systembeschreibung

Federgehäuse

- Direkt- und Indirektsteckverbinder mit Schneidklemmanschluß mit Innen- oder Außenverrastung entsprechend der Weißgeräte-Spezifikation RAST 5
- Direktsteckverbinder mit Mitten- und Seitenwand-Codierung, Verrastung auf Platine
- Kabelabgänge 90° und 180° nach RAST 5

Messerleisten

- Ausführung in vertikaler oder horizontaler Steckrichtung zur Leiterplatte, siehe Serien ECO-FLEX M und TL 2

Description of system

IDC housings

- Direct and indirect connector with IDC termination in accordance with the RAST 5 standard specifications for domestic appliances, with locking features inside or outside
- Direct connector with central polarizing and polarizing pegs at sides, locking features for PCB
- Cable exit 90° and 180° according to RAST 5

Tab connectors

- Versions for vertical or horizontal PC board assembly, see series ECO-FLEX M and TL 2

Bestellbeispiel

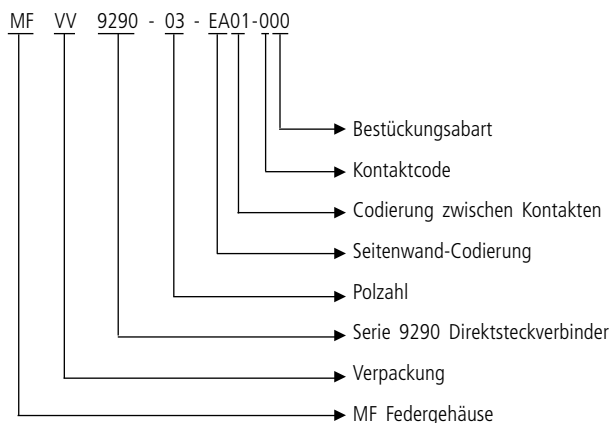

Example for ordering

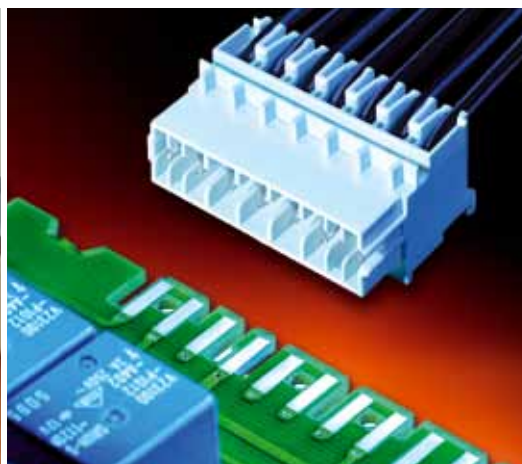
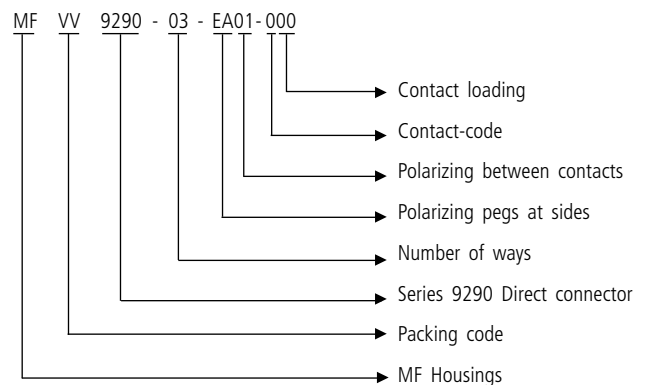

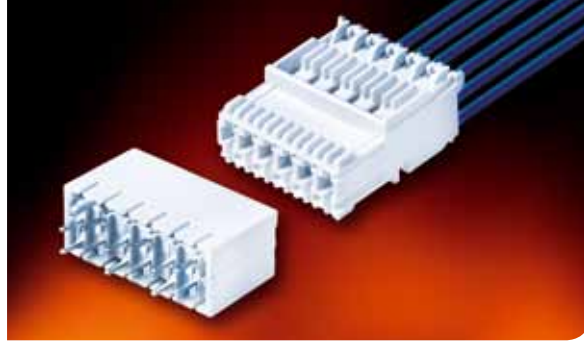

Technische Daten

Mechanisch

Raster		5 mm
Polzahl	Direktstecker	2 - 12
	Indirektstecker	1 - 12
Verrastung	Direktstecker	PCB
	Indirektstecker	Innen und außen
Anschlußart		Schneidklemmtechnik
Leiterquerschnitt	Direktstecker	0,5 - 0,75 mm ²
	Indirektstecker	0,35 - 1,5 mm ²
Isolations Ø		3,0 mm
	Kabelabgang 180°	max. < 2,4 mm
Leiteraufbau		Litze
Temperaturbereich		- 40 °C ...+ 110 °C

Elektrisch

Bemessungsstrom	Direktstecker	6 A
	Indirektstecker	16 A
Bemessungsspannung	ECO-DOMO	400 V
	ECO-DOMO NF	250 V
Durchschlagsfestigkeit		≥ 3,0 kV
Gehäusematerial		
Isolationswiderstand		≥ 10 ⁹ Ω
Durchgangswiderstand		≤ 5 m Ω
Luftstrecke		≥ 3 mm
Kriechstrecke	ECO-DOMO	≥ 3 mm
	ECO-DOMO NF	≥ 3,6 mm
Kriechstromfestigkeit	ECO-DOMO	CTI ≥ 600
	ECO-DOMO NF	CTI ≥ 400
Freigaben		DIN EN 61984 (IEC 61984) UL / ULC E96569

Werkstoffe

Kontakt		Feder: CuSn
Kontaktoberfläche		Feder: Sn
Isolierkörper	ECO-DOMO	PBT
	ECO-DOMO NF	PA, glühdrahtbeständig, GWT 750°C nach IEC 60335-1 natur
Gehäusefarbe		

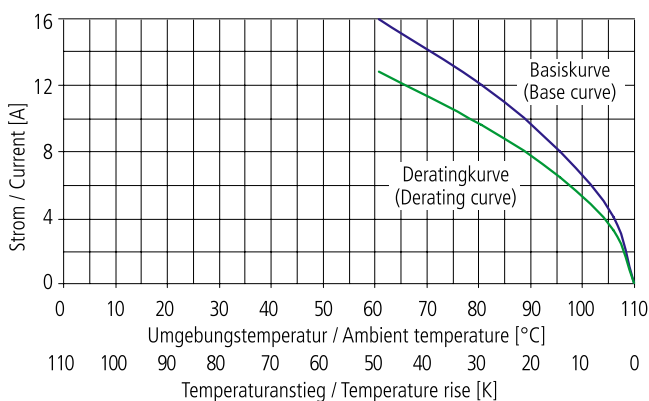

Technical data

Mechanical

Pitch		5 mm
Positions	Direct connector	2 - 12
	Indirect connector	1 - 12
Locking features	Direct connector	PCB
	Indirect connector	inside and outside
Termination		IDC
Wire size	Direct connector	0.5 - 0.75 mm ²
	Indirect connector	0.35 - 1.5 mm ²
Insulation Ø		3.0 mm
	Cable exit 180°	max. < 2.4 mm
Type of wire		stranded
Temperature range		- 40 °C ...+ 110 °C

Electrical

Current rating	Direct connector	6 A
	Indirect connector	16 A
Nom. voltage	ECO-DOMO	400 V
	ECO-DOMO NF	250 V
Dielectrical strength		≥ 3.0 kV
Insulation resistance		≥ 10 ⁹ Ω
Contact resistance		≤ 5 m Ω
Air gap		≥ 3 mm
Creeping distance	ECO-DOMO	≥ 3 mm
	ECO-DOMO NF	≥ 3.6 mm
Tracking resistance	ECO-DOMO	CTI ≥ 600
	ECO-DOMO NF	CTI ≥ 400
Approved by		DIN EN 61984 (IEC 61984) UL / ULC E96569

Materials

Contact		Socket: CuSn
Contact finishing		Socket: Sn
Housing	ECO-DOMO	PBT
	ECO-DOMO NF	PA, glow wire resistant, GWT 750°C acc. to IEC 60335-1 natural
Colour of housing		

Derating-Kurve / Derating curve

Leiterquerschnitt: 0,50 mm² / 2-poliger Stecker / Indirektsteckung
Wire size: 0.50 mm² / 2-way connector / indirect



Serie MF 9290

Federgehäuse in Schneidklemmtechnik

Series MF 9290

IDC housings

Serie MF 9290 Direktstecker mit Mittencodierung, seitlichen Codierstegen und Rastnocken
Series MF 9290 direct connector with central polarizing pegs, polarizing pegs at sides and locking features

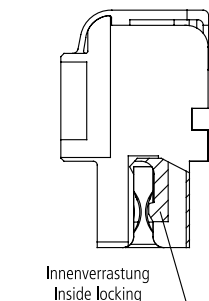
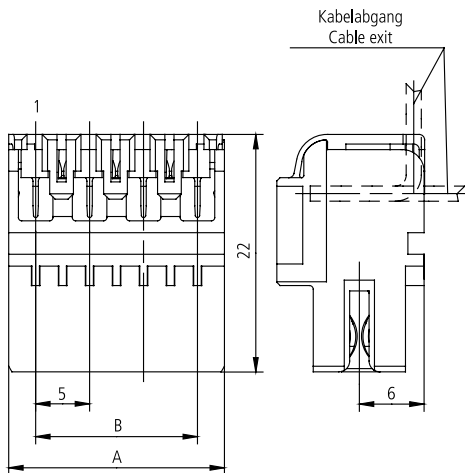
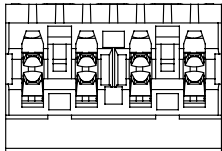

Polzahl Positions	Artikel-Nummer Part number	Codierung zw. Kammer Polarizing between cavities nos.	Verrastung zw. Kammer Locking between cavities nos.
2	MFVV 9290 - 02 - * 01 - 000	-	1 + 2
3	MFVV 9290 - 03 - * 02 - 000	-	1 + 2 / 2 + 3
4	MFVV 9290 - 04 - * 01 - 000	2 + 3	1 + 2 / 3 + 4
5	MFVV 9290 - 05 - * 01 - 000	2 + 3	1 + 2 / 4 + 5
6	MFVV 9290 - 06 - * 01 - 000	2 + 3	1 + 2 / 5 + 6
7	MFVV 9290 - 07 - * 01 - 000	2 + 3	1 + 2 / 6 + 7
8	MFVV 9290 - 08 - * 01 - 000	2 + 3	1 + 2 / 7 + 8
9	MFVV 9290 - 09 - * 01 - 000	2 + 3 / 6 + 7	1 + 2 / 8 + 9
10	MFVV 9290 - 10 - * 01 - 000	2 + 3 / 7 + 8	1 + 2 / 9 + 10
11	MFVV 9290 - 11 - * 01 - 000	2 + 3 / 8 + 9	1 + 2 / 10 + 11
12	MFVV 9290 - 12 - * 01 - 000	2 + 3 / 9 + 10	1 + 2 / 11 + 12

Polzahl Positions	Artikel-Nummer Part number	Abmessungen A Dimensions A	Abmessungen B Dimensions B
2	MFVV 9290 - 02 - * 01 - 000	10	5
3	MFVV 9290 - 03 - * 02 - 000	15	10
4	MFVV 9290 - 04 - * 01 - 000	20	15
5	MFVV 9290 - 05 - * 01 - 000	25	20
6	MFVV 9290 - 06 - * 01 - 000	30	25
7	MFVV 9290 - 07 - * 01 - 000	35	30
8	MFVV 9290 - 08 - * 01 - 000	40	35
9	MFVV 9290 - 09 - * 01 - 000	45	40
10	MFVV 9290 - 10 - * 01 - 000	50	45
11	MFVV 9290 - 11 - * 01 - 000	55	50
12	MFVV 9290 - 12 - * 01 - 000	60	55

* Bitte fügen Sie hier die Abarten-Nummer der Seitencodierung gemäß der Codiertabellen auf den Seiten 40 + 41 ein.

Beispiel: MFVV 9290 - 02 - EA01 - 000 2poliger Direktstecker mit Seitencodierung EA, Mittencodierung 01 und Platinenverrastung

* Please enter here the version number for the polarizing pegs at sides as per polarizing charts see pages 40 + 41.

Example: MFVV 9290 - 02 - EA01 - 000 2-ways direct connector with polarizing pegs at side EA, central polarizing 01 and locking features on PBC.

Serie MF 9590, ECO-DOMO NF

Federgehäuse in Schneidklemmtechnik

Series MF 9590, ECO-DOMO NF

IDC housings

Serie MF 9590 Direktstecker mit Mittencodierung, seitlichen Codierstegen und Rastnocken

Series MF 9590 direct connector with central polarizing pegs, polarizing pegs at sides and locking features

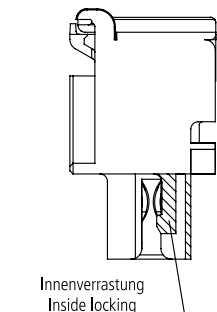
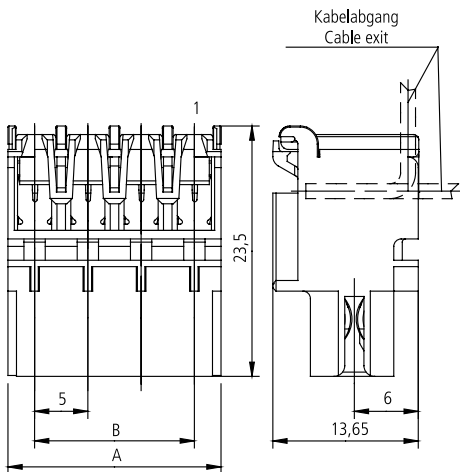
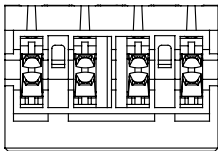

Polzahl Positions	Artikel-Nummer Part number	Codierung zw. Kammer Polarizing between cavities nos.	Verrastung zw. Kammer Locking between cavities nos.
2	MFVV 9590 - 02 - * 01 - 000	-	1 + 2
3	MFVV 9590 - 03 - * 02 - 000	-	1 + 2 / 2 + 3
4	MFVV 9590 - 04 - * 01 - 000	2 + 3	1 + 2 / 3 + 4
5	MFVV 9590 - 05 - * 01 - 000	2 + 3	1 + 2 / 4 + 5
6	MFVV 9590 - 06 - * 01 - 000	2 + 3	1 + 2 / 5 + 6
7	MFVV 9590 - 07 - * 01 - 000	2 + 3	1 + 2 / 6 + 7
8	MFVV 9590 - 08 - * 01 - 000	2 + 3	1 + 2 / 7 + 8
9	MFVV 9590 - 09 - * 01 - 000	2 + 3 / 6 + 7	1 + 2 / 8 + 9
10	MFVV 9590 - 10 - * 01 - 000	2 + 3 / 7 + 8	1 + 2 / 9 + 10
11	MFVV 9590 - 11 - * 01 - 000	2 + 3 / 8 + 9	1 + 2 / 10 + 11
12	MFVV 9590 - 12 - * 01 - 000	2 + 3 / 9 + 10	1 + 2 / 11 + 12

Polzahl Positions	Artikel-Nummer Part number	Abmessungen A Dimensions A	Abmessungen B Dimensions B
2	MFVV 9590 - 02 - * 01 - 000	10	5
3	MFVV 9590 - 03 - * 02 - 000	15	10
4	MFVV 9590 - 04 - * 01 - 000	20	15
5	MFVV 9590 - 05 - * 01 - 000	25	20
6	MFVV 9590 - 06 - * 01 - 000	30	25
7	MFVV 9590 - 07 - * 01 - 000	35	30
8	MFVV 9590 - 08 - * 01 - 000	40	35
9	MFVV 9590 - 09 - * 01 - 000	45	40
10	MFVV 9590 - 10 - * 01 - 000	50	45
11	MFVV 9590 - 11 - * 01 - 000	55	50
12	MFVV 9590 - 12 - * 01 - 000	60	55

* Bitte fügen Sie hier die Abarten-Nummer der Seitencodierung gemäß der Codiertabellen auf den Seiten 40 + 41 ein.

Beispiel: MFVV 9590 - 02 - EA01 - 000 2poliger Direktstecker mit Seitencodierung EA, Mittencodierung 01 und Platinenverrastung

Vorzugstypen siehe Codiertabellen auf den Seiten 42+43

* Please enter here the version number for the polarizing pegs at sides as per polarizing charts see pages 40 + 41.

Example: MFVV 9590 - 02 - EA01 - 000 2-ways direct connector with polarizing pegs at side EA, central polarizing 01 and locking features on PBC.

Preferential versions see polarizing charts on pages 42+43.

Versionen Außenwandcodierung

ECO-DOMO MF 9290 / MF 9590

Versions outside wall coding

ECO-DOMO MF 9290 / MF 9590

Draufsicht Bestückungsseite, Kabelabgang nach oben
Top view on PCB, wire direction upside

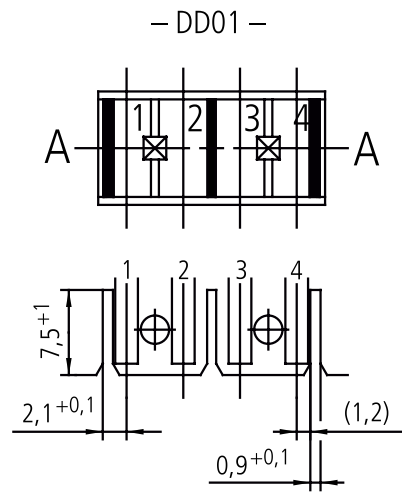
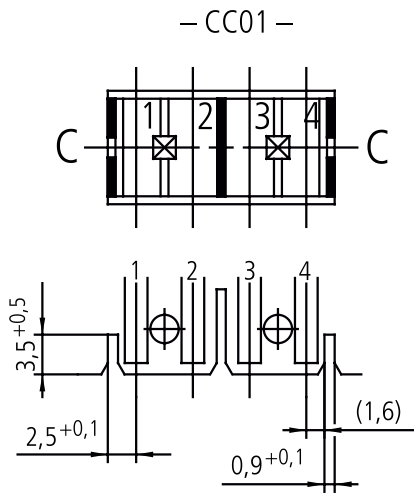
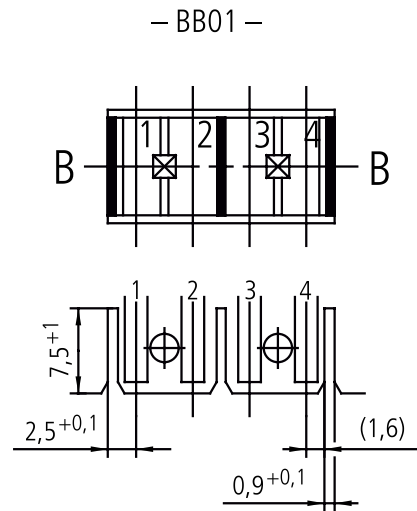
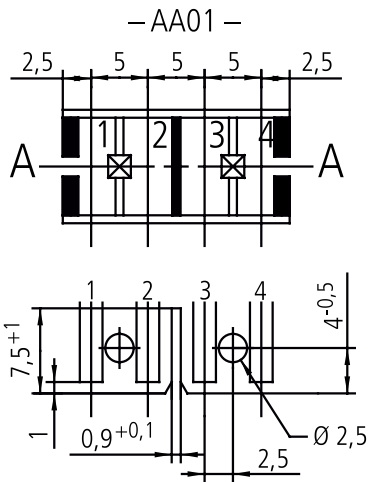

Die seitlichen Codierstege sind polzahlunabhängig.
Polarizing pegs at sides are valid for all number of ways.

Versionen Außenwandcodierung

ECO-DOMO MF 9290 / MF 9590

Versions outside wall coding

ECO-DOMO MF 9290 / MF 9590

Draufsicht Bestückungsseite, Kabelabgang nach oben
Top view on PCB, wire direction upside

– EE01 –

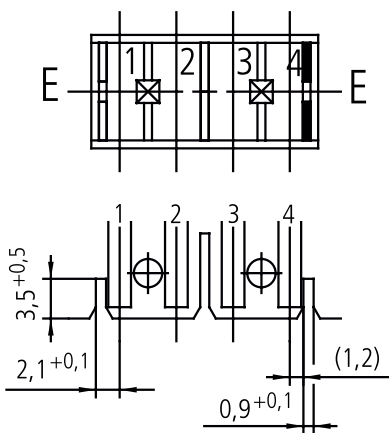

– FF01 –

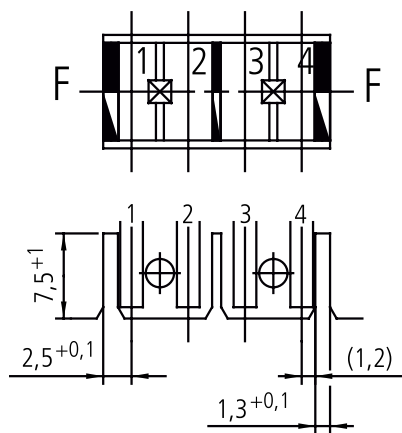

– GG01 –

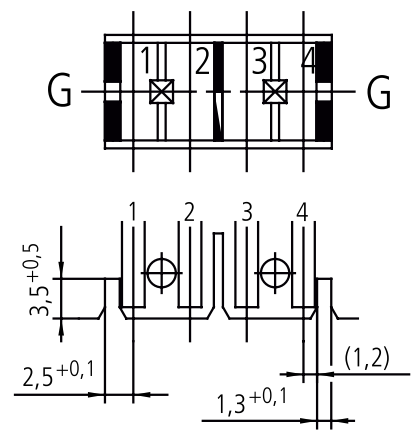

Kombinationsmöglichkeiten / Combination alternatives

– EF01 –

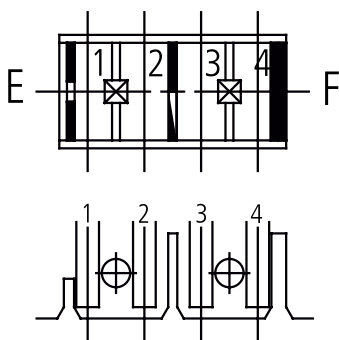

– EA01 –

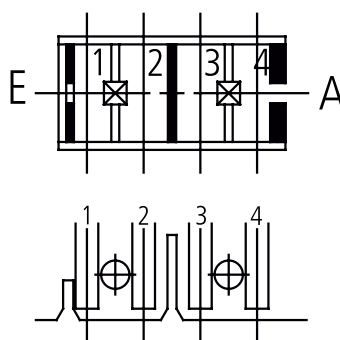

Die seitlichen Codierstege sind polzahlunabhängig.
Polarizing pegs at sides are valid for all number of ways.

Vorzugstypen Außenwandcodierung

ECO-DOMO MF 9590

Preferential types outside wall coding

ECO-DOMO MF 9590

Draufsicht Bestückungsseite, Kabelabgang nach oben
Top view on PCB, wire direction upside

2polig / 2-way

MF 9590-002-BB01-

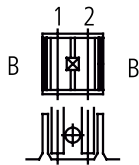

MF 9590-002-EF01-

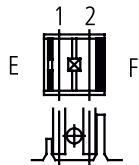

3polig / 3-way

MF 9590-003-AA04-

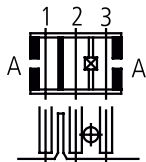

MF 9590-003-EF02-

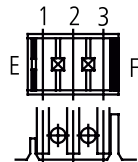

4polig / 4-way

MF 9590-004-AA05-

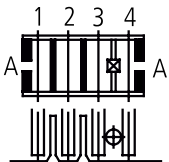

MF 9590-004-EF01-

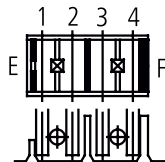

MF 9590-004-EF02-

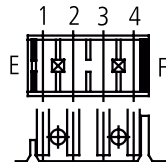

MF 9590-004-FF06-

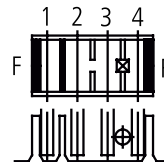

5polig / 5-way

MF 9590-005-AB01-

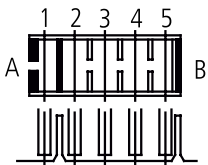

MF 9590-005-EF01-

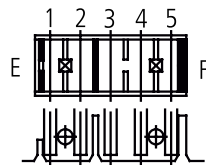

MF 9590-005-EF02-

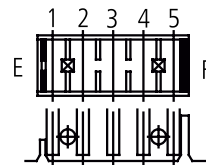

6polig / 6-way

MF 9590-006-EF01-

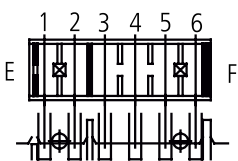

Die seitlichen Codierstege sind polzahlunabhängig.
Polarizing pegs at sides are valid for all number of ways.

Vorzugstypen Außenwandcodierung

ECO-DOMO MF 9590

Preferential types outside wall coding

ECO-DOMO MF 9590

Draufsicht Bestückungsseite, Kabelabgang nach oben
Top view on PCB, wire direction upside

7polig / 7-way

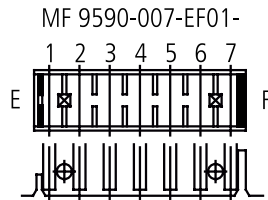
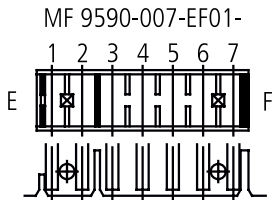

8polig / 8-way

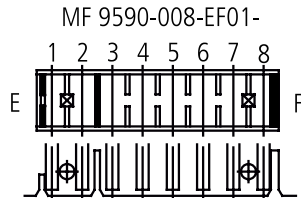

9polig / 9-way

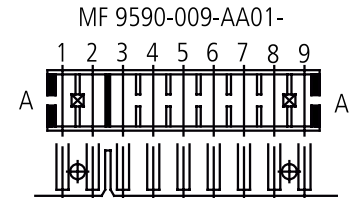

9polig / 9-way

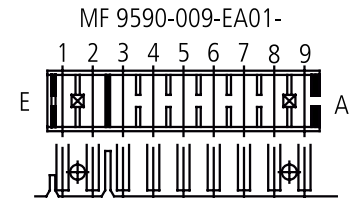
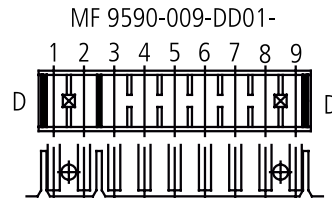
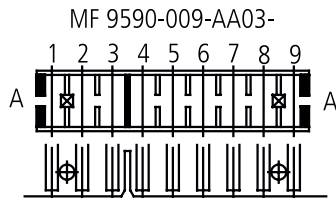

11polig / 11-way

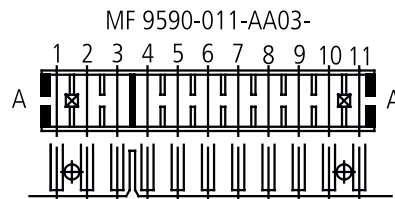
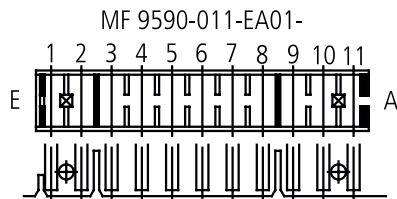

12polig / 12-way

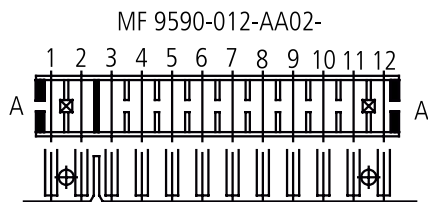

Serie MF 9270

Federgehäuse in Schneidklemmtechnik

Series MF 9270

IDC housings

Serie MF 9270 Direktstecker für Einzelleiter, mit Außenverrastung

Series MF 9270 direct connector for discrete wire, with locking feature outside

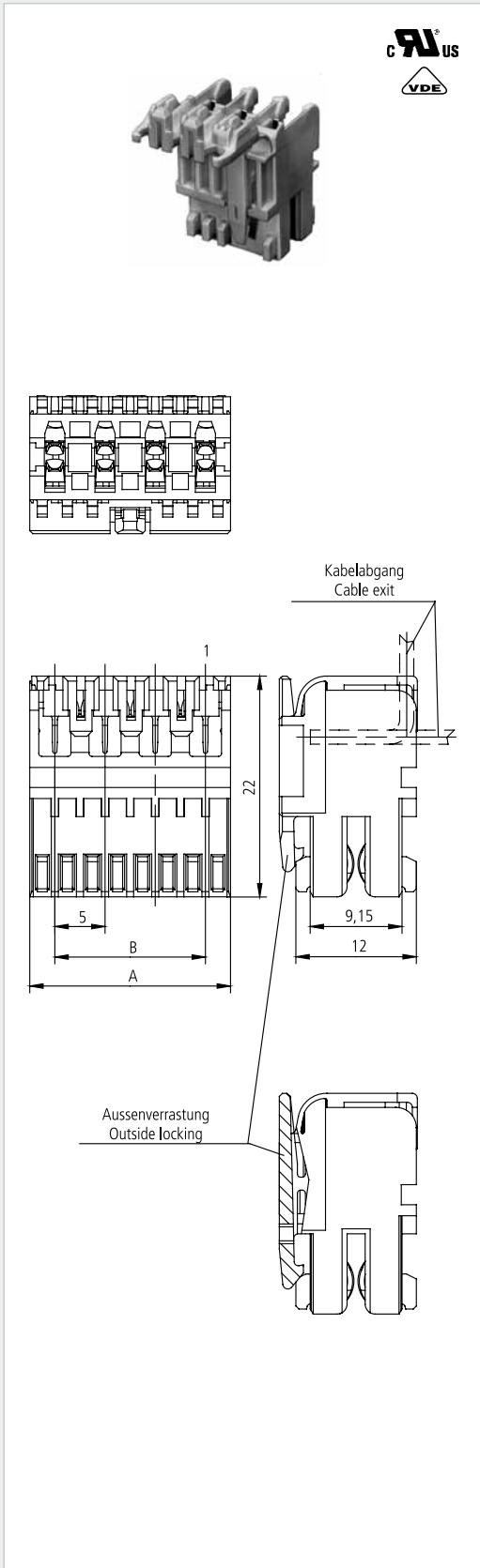

Polzahl Positions	Artikel-Nummer Part number	Abmessungen A Dimensions A	Abmessungen B Dimensions B
2	MFVV 9270 - 002 - *	10	5
3	MFVV 9270 - 003 - *	15	10
4	MFVV 9270 - 004 - *	20	15
5	MFVV 9270 - 005 - *	25	20
6	MFVV 9270 - 006 - *	30	25
7	MFVV 9270 - 007 - *	35	30
8	MFVV 9270 - 008 - *	40	35
9	MFVV 9270 - 009 - *	45	40
10	MFVV 9270 - 010 - *	50	45
11	MFVV 9270 - 011 - *	55	50
12	MFVV 9270 - 012 - *	60	55

* Bitte fügen Sie hier die Abarten-Nummer gemäß der RAST 5 Codiertabellen auf den Seiten 100 - 102 ein.

Beispiel: MFVV 9270 - 002 - 0A 2poliger Direktstecker mit Codierung 0A nach RAST 5 und Außenverrastung

* Please enter here the version number as per the RAST 5 polarizing chart. See pages 100 - 102.

Example: MFVV 9270 - 002 - 0A 2-way direct connector with polarizing 0A to RAST 5 and locking feature outside

Serie MF 9271

Federgehäuse in Schneidklemmtechnik

Series MF 9271

IDC housings

Serie MF 9271 Direktstecker für Einzelleiter, mit Innenverrastung

Series MF 9271 direct connector for discrete wire, with locking feature inside

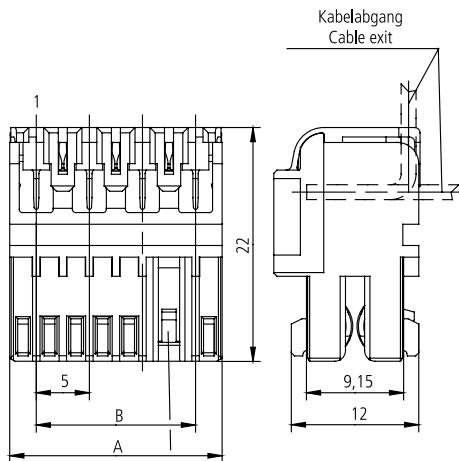
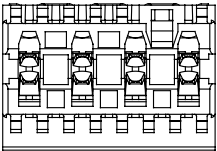

Innenverrastung
Inside locking

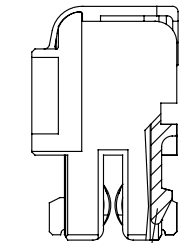

Innenverrastung
Inside locking

Polzahl Positions	Artikel-Nummer Part number	Abmessungen A Dimensions A	Abmessungen B Dimensions B
2	MFVV 9271 - 002 - *	10	5
3	MFVV 9271 - 003 - *	15	10
4	MFVV 9271 - 004 - *	20	15
5	MFVV 9271 - 005 - *	25	20
6	MFVV 9271 - 006 - *	30	25
7	MFVV 9271 - 007 - *	35	30
8	MFVV 9271 - 008 - *	40	35
9	MFVV 9271 - 009 - *	45	40
10	MFVV 9271 - 010 - *	50	45
11	MFVV 9271 - 011 - *	55	50
12	MFVV 9271 - 012 - *	60	55

* Bitte fügen Sie hier die Abarten-Nummer gemäß der RAST 5 Codiertabellen auf den Seiten 100 - 102 ein.

Beispiel: MFVV 9271 - 002 - 0A 2poliger Direktstecker mit Codierung 0A nach RAST 5 und Innenverrastung

* Please enter here the version number as per the RAST 5 polarizing chart. See pages 100 - 102.

Example: MFVV 9271 - 002 - 0A 2-way direct connector with polarizing 0A to RAST 5 and locking feature inside

Serie MF 9260

Federgehäuse in Schneidklemmtechnik

Series MF 9260

IDC housings

Serie MF 9260 Indirektstecker für Einzelleiter, mit Außenverrastung

Series MF 9260 indirect connector for discrete wire, with locking feature outside

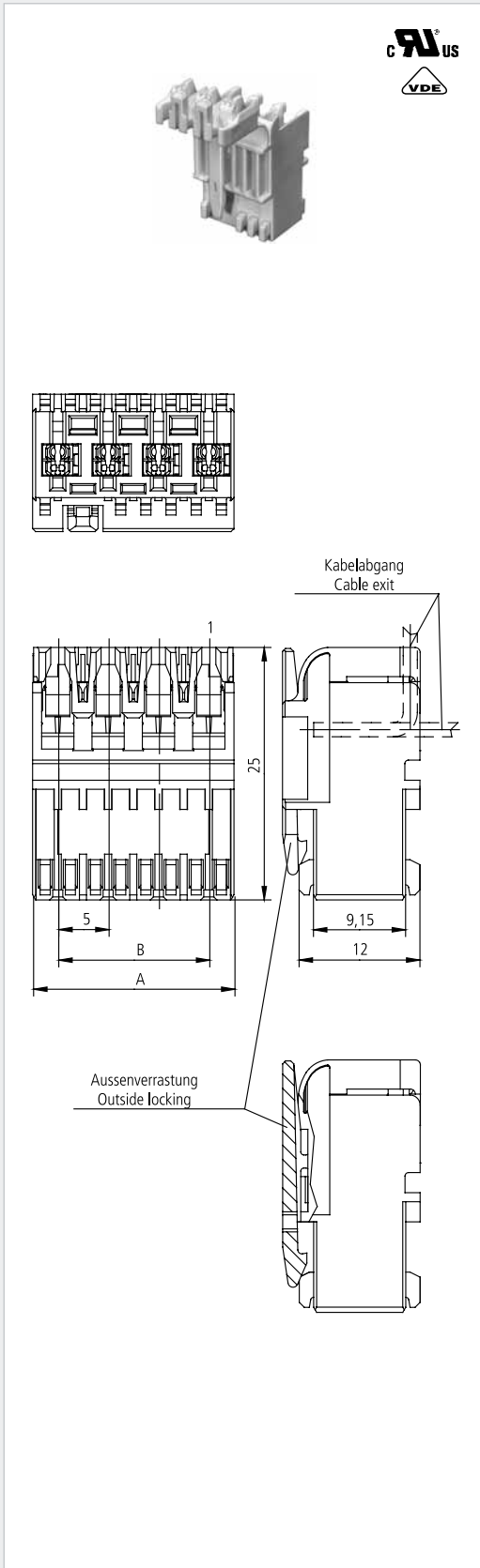

Polzahl Positions	Artikel-Nummer Part number	Abmessungen A Dimensions A	Abmessungen B Dimensions B
2	MFVV 9260 - 002 - 8 *	10	5
3	MFVV 9260 - 003 - 8 *	15	10
4	MFVV 9260 - 004 - 8 *	20	15
5	MFVV 9260 - 005 - 8 *	25	20
6	MFVV 9260 - 006 - 8 *	30	25
7	MFVV 9260 - 007 - 8 *	35	30
8	MFVV 9260 - 008 - 8 *	40	35
9	MFVV 9260 - 009 - 8 *	45	40
10	MFVV 9260 - 010 - 8 *	50	45
11	MFVV 9260 - 011 - 8 *	55	50
12	MFVV 9260 - 012 - 8 *	60	55

* Bitte fügen Sie hier die Abarten-Nummer gemäß der RAST 5 Codiertabellen auf den Seiten 100 - 102 ein.

Beispiel: MFVV 9260 - 002 - 80A 2poliger Indirektstecker mit Codierung 0A nach RAST 5 und Außenverrastung

* Please enter here the version number as per the RAST 5 polarizing chart. See pages 100 - 102.

Example: MFVV 9260 - 002 - 80A 2-way indirect connector with polarizing 0A to RAST 5 and locking feature outside

Serie MF 9560

Federgehäuse in Schneidklemmtechnik

Series MF 9560

IDC housings

Serie MF 9560 Indirektstecker für Einzelleiter, mit Außenverrastung

Series MF 9560 indirect connector for discrete wire, with locking feature outside

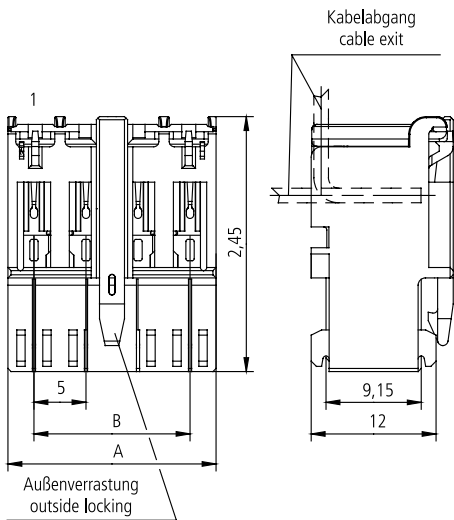
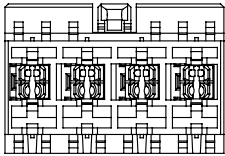

Polzahl Positions	Artikel-Nummer Part number	Abmessungen A Dimensions A	Abmessungen B Dimensions B
3	MFVV 9560 - 003 - *	15	10
4	MFVV 9560 - 004 - *	20	15
5	MFVV 9560 - 005 - *	25	20
6	MFVV 9560 - 006 - *	30	25
7	MFVV 9560 - 007 - *	35	30
8	MFVV 9560 - 008 - *	40	35
9	MFVV 9560 - 009 - *	45	40
10	MFVV 9560 - 010 - *	50	45
11	MFVV 9560 - 011 - *	55	50
12	MFVV 9560 - 012 - *	60	55

* Bitte fügen Sie hier die Abarten-Nummer gemäß der RAST 5 Codiertabellen auf den Seiten 100 - 102 ein.

Beispiel: MFVV 9560 - 008 - W81 8poliger Indirektstecker mit Codierung 81 nach RAST 5 und Außenverrastung

* Please enter here the version number as per the RAST 5 polarizing chart. See pages 100 - 102.

Example: MFVV 9560 - 008 - W81 8-way indirect connector with polarizing 81 to RAST 5 and locking feature outside

Serie MF 9562, ECO-DOMO NF

Federgehäuse in Schneidklemmtechnik

Series MF 9562, ECO-DOMO NF

IDC housings

Serie MF 9562 Indirektstecker mit Rastnase Series MF 9562 indirect connector with alternative locking peg

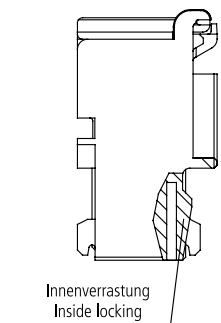
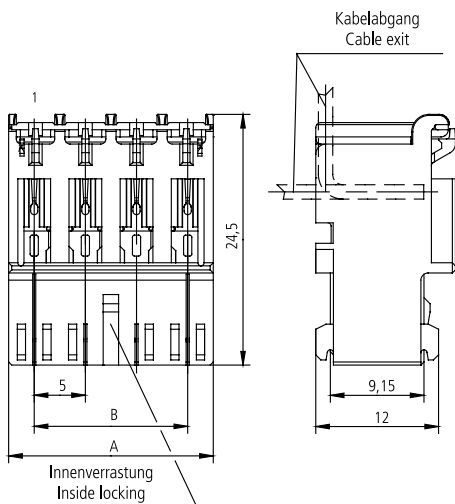
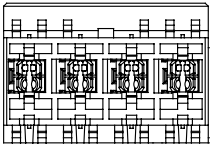

Polzahl Positions	Artikel-Nummer Part number	Abmessungen A Dimensions A	Abmessungen B Dimensions B
2	MFVV 9562 - 002 - 8 *	10	5
3	MFVV 9562 - 003 - 8 *	15	10
4	MFVV 9562 - 004 - 8 *	20	15
5	MFVV 9562 - 005 - 8 *	25	20
6	MFVV 9562 - 006 - 8 *	30	25
7	MFVV 9562 - 007 - 8 *	35	30
8	MFVV 9562 - 008 - 8 *	40	35
9	MFVV 9562 - 009 - 8 *	45	40
10	MFVV 9562 - 010 - 8 *	50	45
11	MFVV 9562 - 011 - 8 *	55	50
12	MFVV 9562 - 012 - 8 *	60	55

* Bitte fügen Sie hier die Abarten-Nummer gemäß der RAST 5 Codiertabellen auf den Seiten 100 - 102 ein.

Beispiel: MFVV 9562 - 002 - 80A 2poliger Indirektstecker mit Codierung 0A nach RAST 5 und Innenverrastung

* Please enter here the version number as per the RAST 5 polarizing chart. See pages 100 - 102.

Example: MFVV 9562 - 002 - 80A 2-way indirect connector with polarizing 0A to RAST 5 and locking feature inside

Serie MF 9286, 9261

Federgehäuse in Schneidklemmtechnik

Series MF 9286, 9261

IDC housings

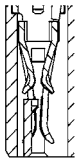

Verrastung für
Flachsteckmesser
Locking feature for tabs

Serie MF 9286 Indirektstecker mit Verrastung für Flachsteckmesser, mit Innenverrastung Series MF 9286 indirect connector with locking feature for tabs, with locking feature inside

Polzahl Positions	Artikel-Nummer Part number	Abmessungen A Dimensions A	Abmessung B Dimensions B
2	MFVV 9286 - 002 - 8 *	10	5
3	MFVV 9286 - 003 - 8 *	15	10

* Bitte fügen Sie hier die Abarten-Nummer gemäß der RAST 5 Codiertabellen auf den Seiten 100 - 102 ein.
Beispiel: MFVV 9286 - 002 - 80A 2poliger Indirektstecker mit Codierung 0A nach RAST 5 und Innenverrastung.

* Please enter here the version number as per the RAST 5 polarizing chart. See page 100 - 102.
Example: MFVV 9286 - 002 - 80A 2-way indirect connector with polarizing 0A to RAST 5 and locking feature inside.

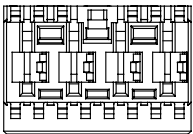
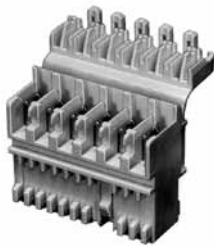

Kabelabgang
Cable exit

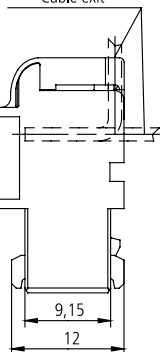
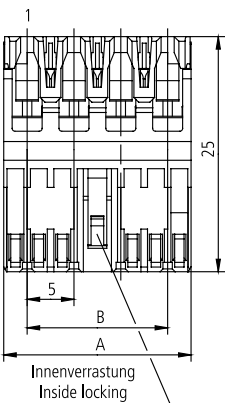

Innenverrastung
Inside locking

Serie MF 9261 Indirektstecker für Einzelleiter, mit Innenverrastung

Series MF 9261 indirect connector for discrete wire, with locking feature inside

Polzahl Positions	Artikel-Nummer Part number	Abmessungen A Dimensions A	Abmessungen B Dimensions B
4	MFVV 9261 - 004 - 8 *	20	15
5	MFVV 9261 - 005 - 8 *	25	20
6	MFVV 9261 - 006 - 8 *	30	25
7	MFVV 9261 - 007 - 8 *	35	30
8	MFVV 9261 - 008 - 8 *	40	35
9	MFVV 9261 - 009 - 8 *	45	40
10	MFVV 9261 - 010 - 8 *	50	45
11	MFVV 9261 - 011 - 8 *	55	50
12	MFVV 9261 - 012 - 8 *	60	55

* Bitte fügen Sie hier die Abarten-Nummer gemäß der RAST 5 Codiertabellen auf den Seiten 100 - 102 ein.
Beispiel: MFVV 9261 - 004 - 80A 4poliger Indirektstecker mit Codierung 0A nach RAST 5 und Innenverrastung

* Please enter here the version number as per the RAST 5 polarizing chart. See pages 100 - 102.
Example: MFVV 9261 - 004 - 80A 4-way indirect connector with polarizing 0A to RAST 5 and locking feature inside

Serie MF 9586, ECO-DOMO NF
 Federgehäuse in Schneidklemmtechnik

Series MF 9586, ECO-DOMO NF
 IDC housings

Serie MF 9586 Indirektstecker mit Verrastung für Flachsteckmesser, mit Innenverrastung
Series MF 9586 indirect connector with locking feature for tabs, with locking feature inside



Verrastung für Flachsteckmesser
 Locking feature for tabs

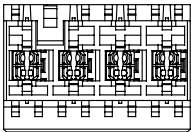

Kabelabgang
 Cable exit

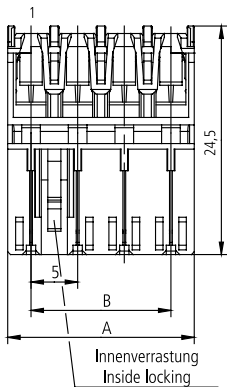

Innenverrastung
 Inside locking

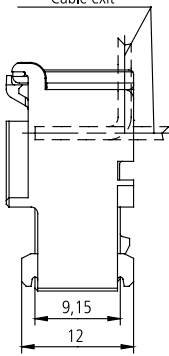

Innenverrastung
 Inside locking

Polzahl Positions	Artikel-Nummer Part number	Abmessungen A Dimensions A	Abmessungen B Dimensions B
2	MFVV 9586 - 002 - 8 *	10	5
3	MFVV 9586 - 003 - 8 *	15	10

* Vorzugstypen siehe Seite 103. Weitere Versionen auf Anfrage.

Beispiel: MFVV 9586 - 002 - 80A 2-poliger Indirektstecker mit Codierung 0A, nach RAST 5 und Innenverrastung.

* Preferential types see page 103. More versions on request.

Example: MFVV 9586 - 002 - 80A 2-ways indirect connector with polarizing 0A to RAST 5 and locking feature inside.

Serie MF 9561, ECO-DOMO NF

Federgehäuse in Schneidklemmtechnik

Series MF 9561, ECO-DOMO NF

IDC housings

Serie MF 9561 Indirektstecker für Einzelleiter, mit Innenverrastung

Series MF 9561 indirect connector for discrete wire, with locking feature inside

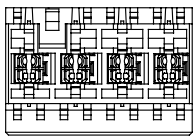
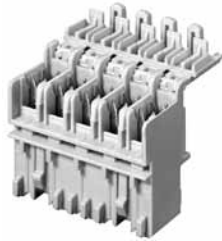

Kabelabgang
Cable exit

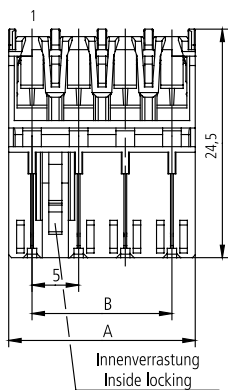
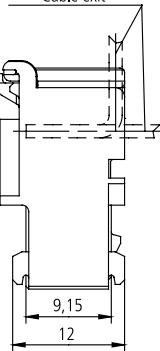

Innenverrastung
Inside locking

Innenverrastung
Inside locking

Polzahl Positions	Artikel-Nummer Part number	Abmessungen A Dimensions A	Abmessungen B Dimensions B
4	MFVV 9561 - 004 - 8 *	20	15
5	MFVV 9561 - 005 - 8 *	25	20
6	MFVV 9561 - 006 - 8 *	30	25
7	MFVV 9561 - 007 - 8 *	35	30
8	MFVV 9561 - 008 - 8 *	40	35
9	MFVV 9561 - 009 - 8 *	45	40
10	MFVV 9561 - 010 - 8 *	50	45
11	MFVV 9561 - 011 - 8 *	55	50
12	MFVV 9561 - 012 - 8 *	60	55

* Vorzugstypen siehe Seite 103. Weitere Versionen auf Anfrage.

Beispiel: MFVV 9561 - 004 - 80A 4poliger Indirektstecker mit Codierung 0A, nach RAST 5 und Innenverrastung.

* Preferential types see page 103. More versions on request.

Example: MFVV 9561 - 004 - 80A 4-ways indirect connector with polarizing 0A to RAST 5 and locking feature inside.

Serie MF 9264

Federgehäuse in Schneidklemmtechnik

Series MF 9264

IDC housings

Serie MF 9264 Indirektstecker mit Rastnase alternativ zu Codiernocken

Series MF 9264 indirect connector with alternative locking peg instead of polarizing pin

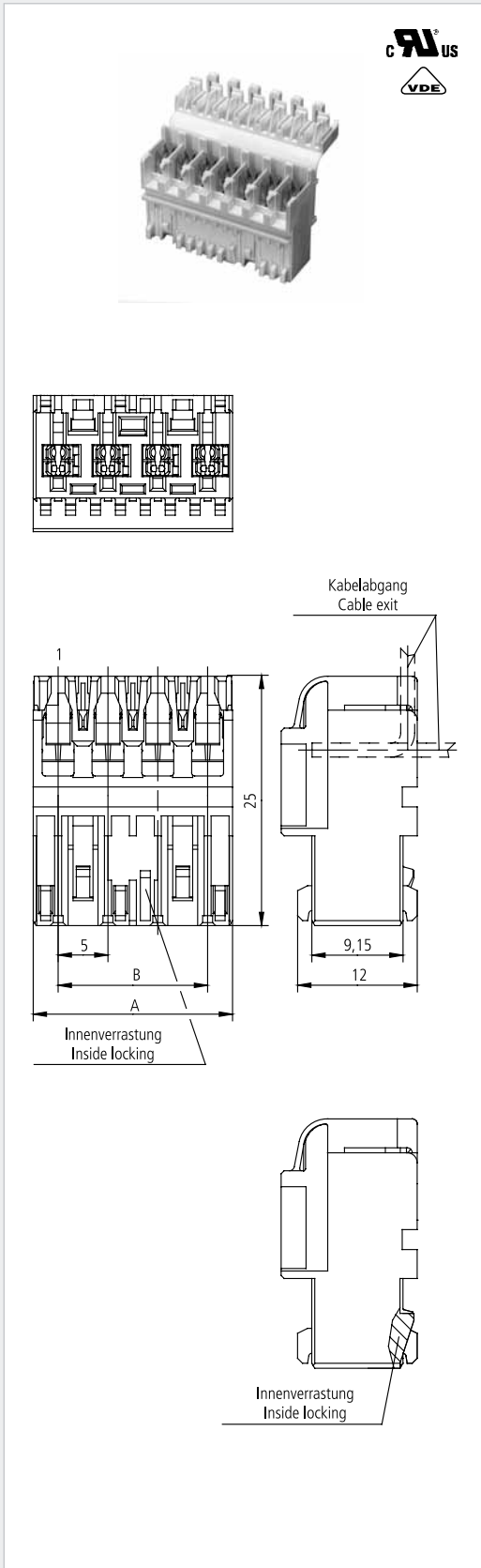

Polzahl Positions	Artikel-Nummer Part number	Abmessungen A Dimensions A	Abmessungen B Dimensions B
2	MFVV 9264 - 002 - 8 *	10	5
3	MFVV 9264 - 003 - 8 *	15	10
4	MFVV 9264 - 004 - 8 *	20	15
5	MFVV 9264 - 005 - 8 *	25	20
6	MFVV 9264 - 006 - 8 *	30	25
7	MFVV 9264 - 007 - 8 *	35	30
8	MFVV 9264 - 008 - 8 *	40	35
9	MFVV 9264 - 009 - 8 *	45	40
10	MFVV 9264 - 010 - 8 *	50	45
11	MFVV 9264 - 011 - 8 *	55	50
12	MFVV 9264 - 012 - 8 *	60	55

* Bitte fügen Sie hier die Abarten-Nummer gemäß der RAST 5 Codiertabellen auf den Seiten 100 - 102 ein.

Beispiel: MFVV 9264 - 002 - 80A 2poliger Indirektstecker mit Codierung 0A nach RAST 5 und Innenverrastung.

* Please enter here the version number as per the RAST 5 polarizing chart. See pages 100 - 102.

Example: MFVV 9264 - 002 - 80A 2-way indirect connector with polarizing 0A to RAST 5 and locking feature inside.

Serie MF 9564, ECO-DOMO NF
Federgehäuse in Schneidklemmtechnik

Series MF 9564, ECO-DOMO NF
IDC housings

Serie MF 9564 Indirektstecker mit Rastnase alternativ zu Codiernocken
Series MF 9564 indirect connector with alternative locking peg instead of polarizing pin

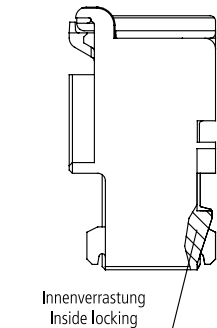
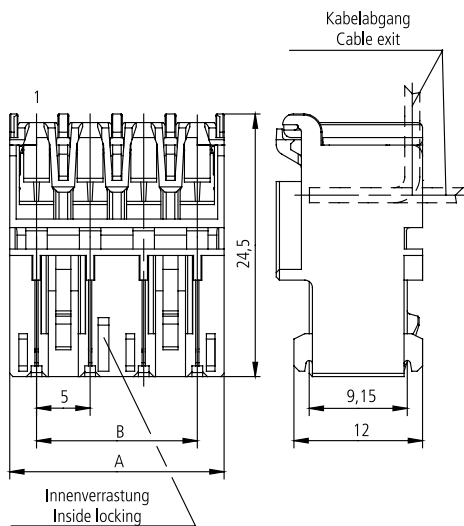
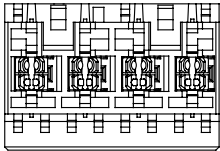
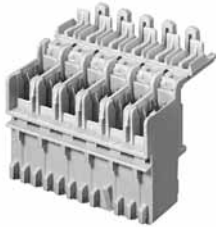

Polzahl Positions	Artikel-Nummer Part number	Abmessungen A Dimensions A	Abmessungen B Dimensions B
2	MFVV 9564 - 002 - 8 *	10	5
3	MFVV 9564 - 003 - 8 *	15	10
4	MFVV 9564 - 004 - 8 *	20	15
5	MFVV 9564 - 005 - 8 *	25	20
6	MFVV 9564 - 006 - 8 *	30	25
7	MFVV 9564 - 007 - 8 *	35	30
8	MFVV 9564 - 008 - 8 *	40	35
9	MFVV 9564 - 009 - 8 *	45	40
10	MFVV 9564 - 010 - 8 *	50	45
11	MFVV 9564 - 011 - 8 *	55	50
12	MFVV 9564 - 012 - 8 *	60	55

* Bitte fügen Sie hier die Abarten-Nummer gemäß der RAST 5 Codiertabellen auf den Seiten 100 - 102 ein.
Beispiel: MFVV 9564 - 002 - 80A 2poliger Indirektstecker mit Codierung 0A nach RAST 5 und Innenverrastung.

* Please enter here the version number as per the RAST 5 polarizing chart. See pages 100 - 102.
Example: MFVV 9564 - 002 - 80A 2-way indirect connector with polarizing 0A to RAST 5 and locking feature inside.

Serie MF 9285

Federgehäuse in Schneidklemmtechnik

Series MF 9285

IDC housings

Serie MF 9285 Indirektstecker mit Verrastung für Flachsteckmesser Series MF 9285 indirect connector with locking feature for tabs

Polzahl Positions	Artikel-Nummer Part number	Abmessungen A Dimensions A	Codierung Polarizing
1 - 2 *	MFVV 9285 - 2 M 1 - 899	5	99
1 - 3	MFVV 9285 - 3 M 1 - 899	5	99

* Anzahl Gehäuse am Riegel

* Number of housings in chain

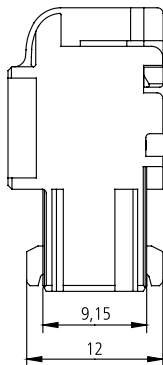
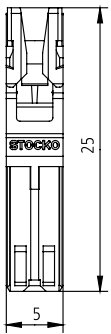
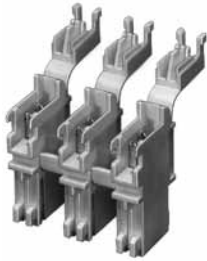

Messverrastung
Tab locking

Serie MF 9585, ECO-DOMO NF
 Federgehäuse in Schneidklemmtechnik

Series MF 9585, ECO-DOMO NF
 IDC housings

Serie MF 9585 Indirektstecker mit Verrastung für Flachsteckmesser
Series MF 9585 indirect connector with locking feature for tabs

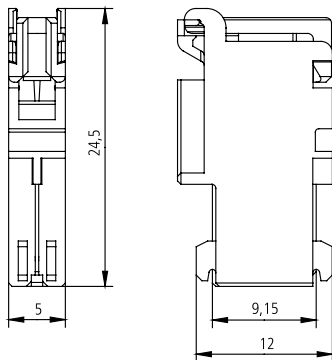
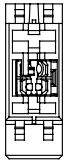

Messerverrastung
 Tab locking

Polzahl Positions	Artikel-Nummer Part number	Abmessungen A Dimensions A	Codierung Polarizing
1 - 2 *	MFVV 9585 - 201 - 899	5	99
1 - 3	MFVV 9585 - 301 - 899	5	99

* Anzahl Gehäuse am Riegel
 * Number of housings in chain

»Steckverbindersystem ECO-DOMO FT« Connector system ECO-DOMO FT

Systembeschreibung

- Indirektstecker mit Schneidklemmanschluß entsprechend der Weißgeräte-Spezifikation RAST 5
- Einsatz in Leistungskreisen bis 10 A
- Komplexe Kabelstränge vollautomatisch produzierbar
- Erfüllung der Anforderung nach RoHS
- Hohe Wirtschaftlichkeit
- Kabelabgang 90°
- Als Direktstecker bietet STOCKO mit der Serie ECO-TRONIC pro eine wirtschaftliche Lösung an (s. Seite 22)

Description of system

- Indirect IDC connector in accordance with the RAST 5 standard specification for domestic appliances
- Suitable for up to 10 A current load
- Complex cable assemblies with fully automated terminating capability
- Meeting RoHS requirements
- Highly economical
- Cable exit at 90°
- As direct connector necessary, STOCKO offers with the series ECO-TRONIC pro an economical solution (s. page 22)

Bestellbeispiel

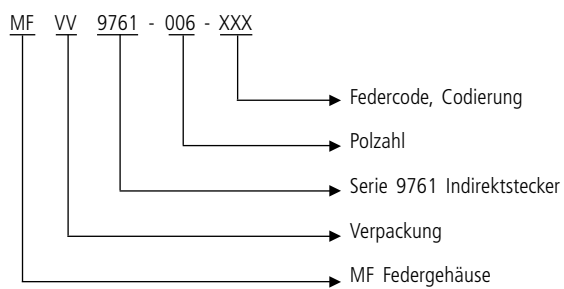

Example of ordering

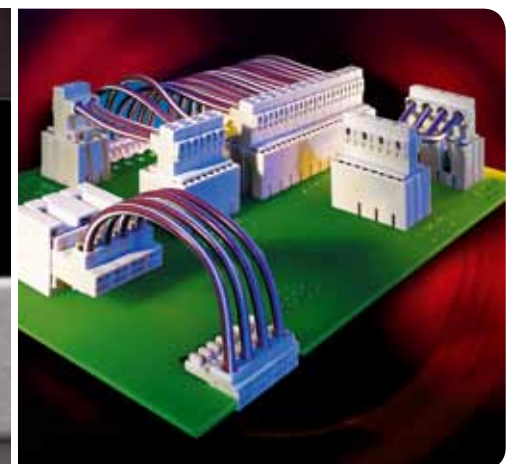
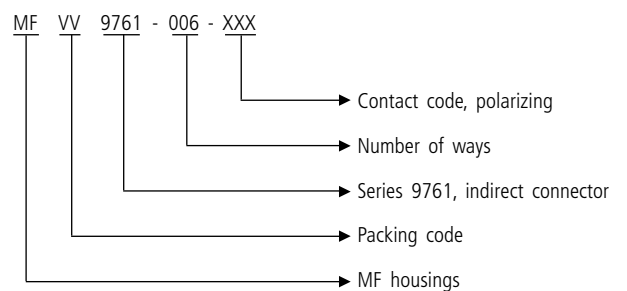

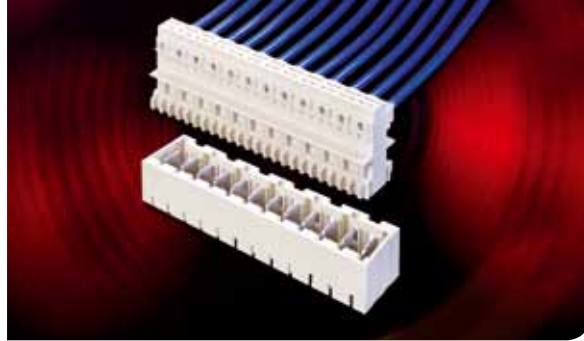

Technische Daten

Mechanisch

Raster	5 mm
Polzahl	1 - 12
Anschlußart	Schneidklemmtechnik
Leiterquerschnitt	0,35 / 0,5-1 mm ²
Leiteraufbau	Litze
Temperaturbereich	-40°C ...+ 120°C

Elektrisch

Bemessungsstrom	10 A
Bemessungsspannung	250 V
Durchschlagfestigkeit	
Gehäusematerial	3,0 kV
Isolationswiderstand	> 10 ⁹ Ω
Durchgangswiderstand	< 5 m Ω
Luft- und Kriechstrecken	> 4 mm
Kriechstromfestigkeit	> 400 CTI
Freigaben	DIN EN 61984 (IEC 61984)

Werkstoffe

Kontakt	Feder: Cu-Legierung
Kontaktoberfläche	Feder: Sn
Isolierkörper	PA, glühdrahtbeständig, GWT 750°C nach IEC 60335-1
Gehäusefarbe	natur
Codierung	nach RAST 5

Technical data

Mechanical

Pitch	5 mm
Positions	1 - 12
Termination	IDC
Wire size	0.35 / 0.5-1 mm ²
Type of wire	stranded
Temperaturbereich	-40°C ...+ 120°C

Electrical

Current rating	10 A
Nom. voltage	250 V
Dielectrical strength	3.0 kV
Insulation resistance	> 10 ⁹ Ω
Contact resistance	< 5 m Ω
Air gap and creeping distances	> 4 mm
Tracking resistance	> 400 CTI
Approved by	DIN EN 61984 (IEC 61984)

Materials

Contact	Socket: Cu-alloy
Contact finishing	Socket: Sn
Housing	PA, glow wire resistant, GWT 750°C acc. to IEC 60335-1
Colour of housing	natural
Polarizing	according to RAST 5

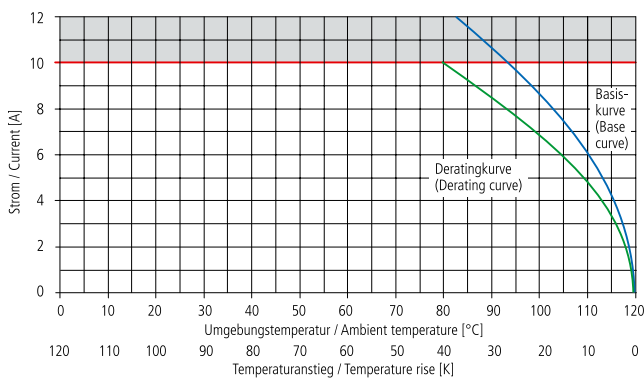

Derating-Kurve / Derating curve

Leiterquerschnitt: 1 mm² / 4-poliger Stecker
Wire size: 1 mm² / 4-way connector

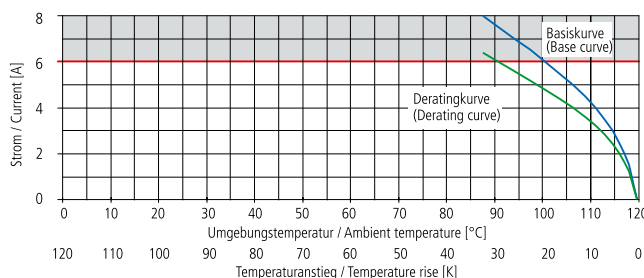

Derating-Kurve / Derating curve

Leiterquerschnitt: 0,5 mm² / 8-poliger Stecker
Wire size: 0.5 mm² / 8-way connector



Serie MF 9761, ECO-DOMO FT
 Federgehäuse in Schneidklemmtechnik

Series MF 9761, ECO-DOMO FT
 IDC housings

Serie MF 9761 Indirektstecker mit Innenverrastung
Series MF 9761 indirect connector with locking feature inside

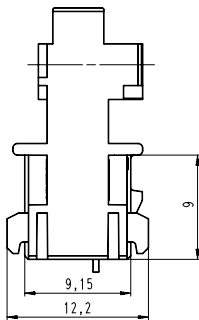
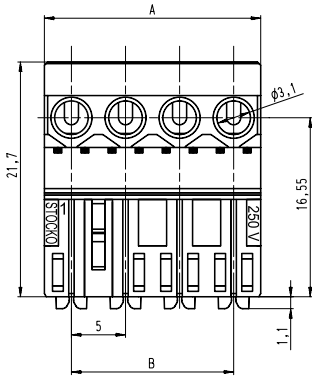
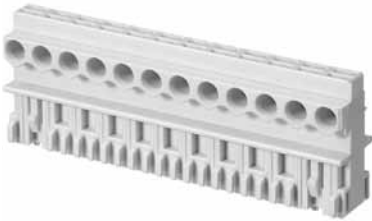

Polzahl Positions	Artikel-Nummer Part number	Abmessungen A Dimensions A	Abmessungen B Dimensions B
2	MFVV 9761 - 002 - *	10	5
3	MFVV 9761 - 003 - *	15	10
4	MFVV 9761 - 004 - *	20	15
5	MFVV 9761 - 005 - *	25	20
6	MFVV 9761 - 006 - *	30	25
7	MFVV 9761 - 007 - *	35	30
8	MFVV 9761 - 008 - *	40	35
9	MFVV 9761 - 009 - *	45	40
10	MFVV 9761 - 010 - *	50	45
11	MFVV 9761 - 011 - *	55	50
12	MFVV 9761 - 012 - *	60	55

- * Codierungen auf Anfrage.
- * Polarizings on request.

Serie MF 9785, ECO-DOMO FT
 Federgehäuse in Schneidklemmtechnik

Series MF 9785, ECO-DOMO FT
 IDC housings

Serie MF 9785 Indirektstecker am Riegel
Series MF 9785 indirect connector in chain

Polzahl Positions	Artikel-Nummer Part number	Abmessungen A Dimensions A
1 - 2*	MFVV 9785 - 201 - *	5
1 - 3*	MFVV 9785 - 301 - *	5

* Anzahl Gehäuse am Riegel / Number of housings in chain

* Codierungen auf Anfrage / Polarizings on request

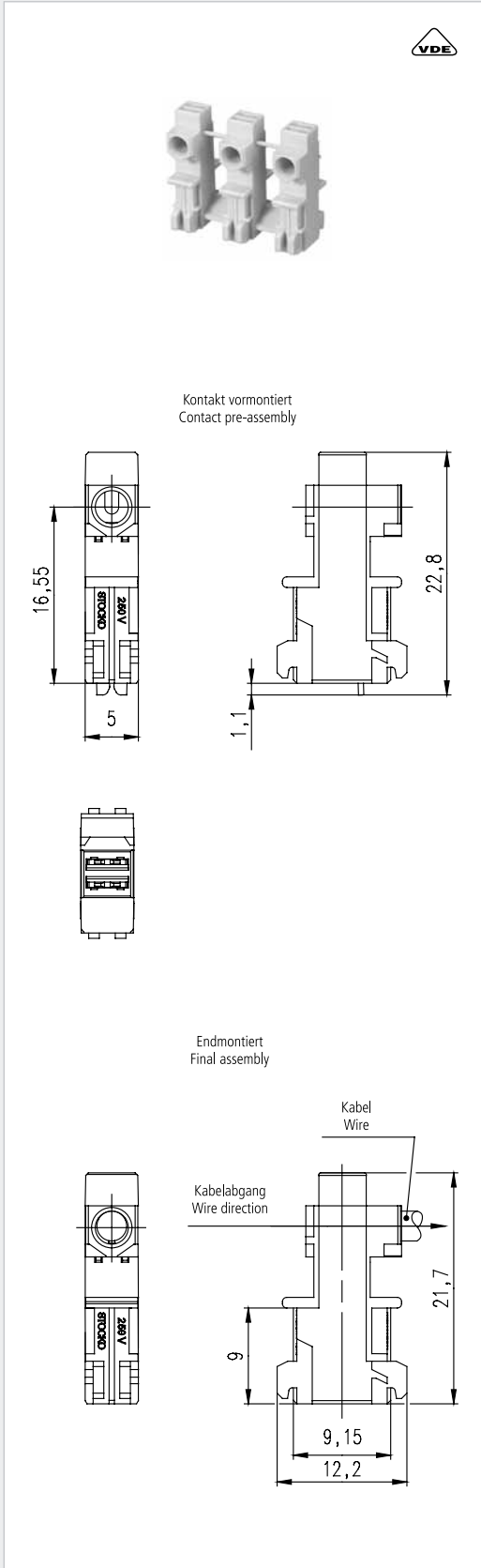

»Steckverbindersystem ECO-DOMO TI«

Connector system ECO-DOMO TI

Systembeschreibung

- Messerleiste mit Schneidklemmanschluß als fliegende Kupplung oder Schottdurchführung
- Ausführung mit / ohne Verrastung
- Leiterabgang 90°, 180° (optional 270°)
- Einzel- und / oder Doppelanschlag in Abhängigkeit zum Leiterquerschnitt
- Individuelle Positionierung und Codierung
- Label optional

Description of system

- Tab connector for IDC termination as flying lead coupling or for panel mounting application
- Versions with / without locking features
- Cable exits 90°, 180° (optional 270°)
- Single and / or twin terminations depending on wire size
- Individual positioning and coding
- Label optional

Bestellbeispiel

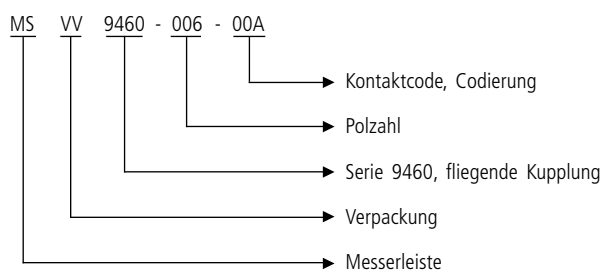

Example for ordering

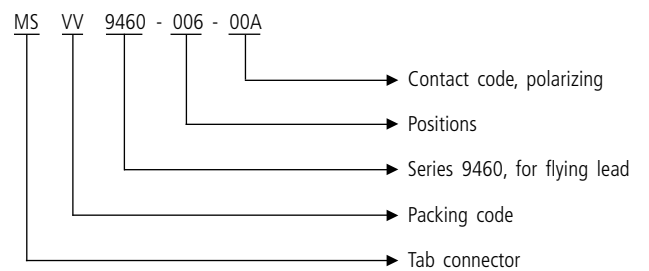

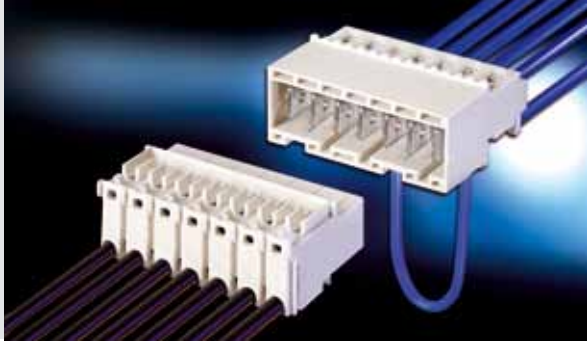

Technische Daten

Mechanisch

Raster	5 mm
Polzahl	2 - 10
Anschlußart	Schneidklemmtechnik
Leiterquerschnitt	0,5 - 0,75 mm ²
Isolations Ø	2,3 mm
Leiteraufbau	Litze
Temperaturbereich	- 40 °C ...+ 110 °C

Electrical

Bemessungsstrom	10 A
Bemessungsspannung	250 V
Durchschlagfestigkeit	
Gehäusematerial	2,5 kV
Kriechstromfestigkeit	CTI ≥ 400
Luft- und Kriechstrecke	≥ 4 mm
Isolationswiderstand	> 10 ⁹ Ω
Durchgangswiderstand	< 10 m Ω
Freigaben	DIN EN 61984 (IEC 61984)

Werkstoffe

Kontakte	Flachmesser 6,3 x 0,8 mm
Kontaktmaterial	CuSn
Kontaktoberfläche	Sn
Isolierkörper	PA, glühdrahtbeständig, GWT 750°C nach IEC 60335-1
Gehäusefarbe	natur

Technical data

Mechanical

Pitch	5 mm
Positions	2 - 10
Termination	IDC
Wire size	0.5 - 0.75 mm ²
Insulation Ø	2.3 mm
Type of wire	stranded wire
Temperature range	- 40 °C ...+ 110 °C

Electrical

Current rating	10 A
Nom. voltage	250 V
Dielectrical strength	2.5 kV
Tracking resistance	CTI ≥ 400
Air gap and creeping distance	≥ 4 mm
Insulation resistance	> 10 ⁹ Ω
Contact resistance	< 10 m Ω
Approved by	DIN EN 61984 (IEC 61984)

Materials

Contact	tabs 6.3 x 0.8 mm
Contact material	CuSn
Contact finishing	Sn
Housings	PA, glow wire resistant, GWT 750°C acc. to IEC 60335-1
Colour of housing	natural

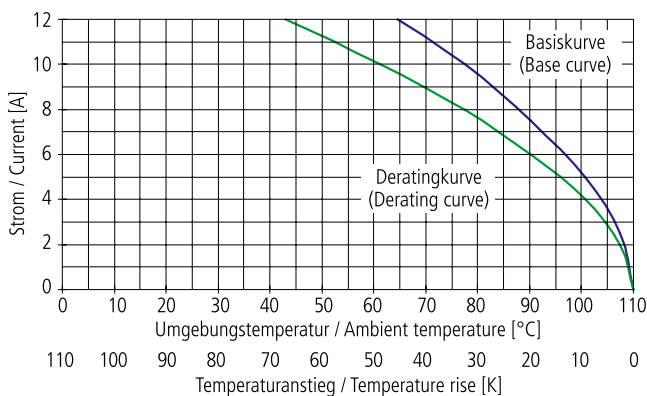

Derating-Kurve / Derating curve

Leiterquerschnitt: 0,75 mm² / 9-poliger Stecker / Indirektsteckung
Wire size: 0.75 mm² / 9-way connector / indirect



Serien MS 9460, ECO-DOMO TI
Messerleiste für Schneidklemmtechnik

Series MS 9460, ECO-DOMO TI
Tab connector IDC

Serie MS 9460 fliegende Kupplung für Indirektsteckverbinder nach RAST 5
Series MS 9460 flying lead for indirect connector according to RAST 5

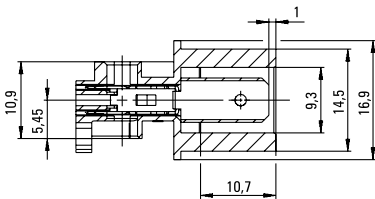
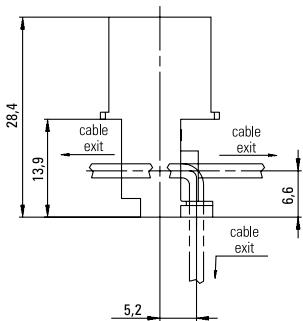
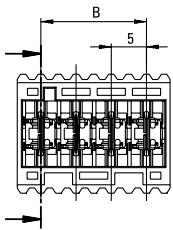
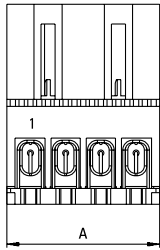

Polzahl Positions	Artikel-Nummer Part number	Abmessungen A Dimensions A	Abmessungen B Dimensions B
2	MSVV 9460 - 002 - *	11,7	5
3	MSVV 9460 - 003 - *	16,7	10
4	MSVV 9460 - 004 - *	21,7	15
5	MSVV 9460 - 005 - *	26,7	20
6	MSVV 9460 - 006 - *	31,7	25
7	MSVV 9460 - 007 - *	36,7	30
8	MSVV 9460 - 008 - *	41,7	35
9	MSVV 9460 - 009 - *	46,7	40
10	MSVV 9460 - 010 - *	51,7	45

- * Codierungen auf Anfrage.
- * Polarizings on request.

Serie MS 9470, ECO-DOMO TI
Messerleiste für Schneidklemmtechnik

Series MS 9470, ECO-DOMO TI
Tab connector IDC

Serie MS 9470 Schottdurchführung für Indirektsteckverbinder nach RAST 5
Series MS 9470 Panel mounting for indirect connector according to RAST 5

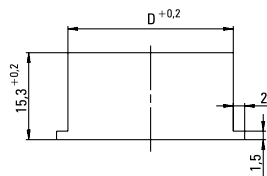
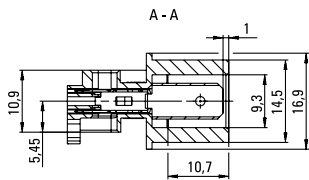
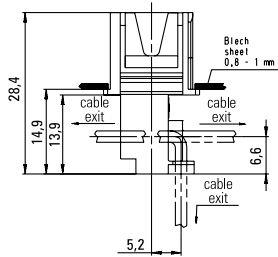
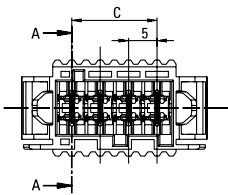
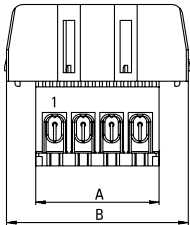

Lochbild
Hole pattern

Polzahl Positions	Artikel-Nummer Part number	Abmessungen A Dimensions A	Abmessungen B Dimensions B	Abmessung C Dimensions C
2	MSVV 9470 - 002 - *	11,7	22	5
3	MSVV 9470 - 003 - *	16,7	27	10
4	MSVV 9470 - 004 - *	21,7	32	15
5	MSVV 9470 - 005 - *	26,7	37	20
6	MSVV 9470 - 006 - *	31,7	42	25
7	MSVV 9470 - 007 - *	36,7	47	30
8	MSVV 9470 - 008 - *	41,7	52	35
9	MSVV 9470 - 009 - *	46,7	57	40
10	MSVV 9470 - 010 - *	51,7	62	45

- * Codierungen auf Anfrage.
- * Polarizings on request.

»Steckverbindersystem ECO-FLEX«

Connector system ECO-FLEX

Systembeschreibung

- Messerleiste mit/ohne Trennwände
- SMT-Ausführung in vertikaler Steckrichtung zur Leiterplatte
- Ausführung in vertikaler oder horizontaler Steckrichtung zur Leiterplatte
- Erhöhte horizontale Ausführung auch geeignet für Steckverbinder mit Außenrastarm
- Kontaktausführung in dual- oder in-line
- Individuelle Positionierung und Codierung
- Positionierzapfen optional

Description of system

- Tab connector with/without separating plate
- SMT version for vertical PC board assembly
- Versions for vertical or horizontal PC board assembly
- Higher horizontal version also suitable for connectors with locking features outside
- For in-line or dual-line hole patterns
- Individual polarizing and positioning possible
- Pegs optional

Bestellbeispiel

RAST 5 Messerleiste
Messerleiste, Codierung 09, 8 pol. für waagrechtes Stecken

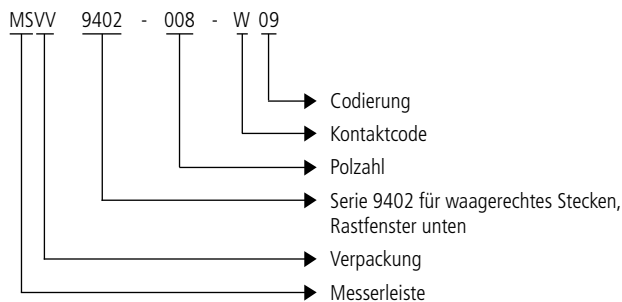

Example for ordering

RAST 5 Tab connectors
Tab connector, polarizing 09, 8-way for horizontal connections

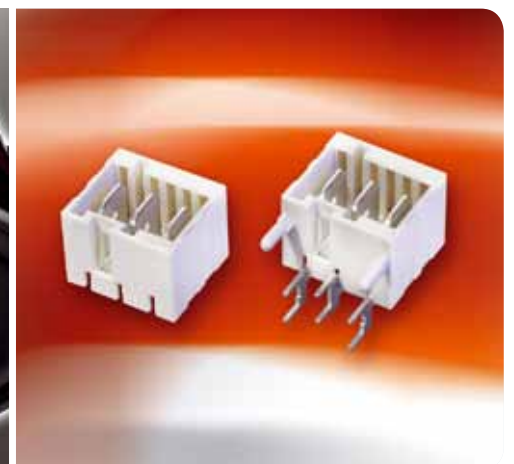
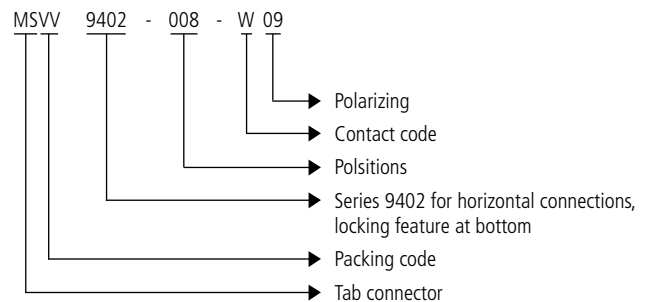

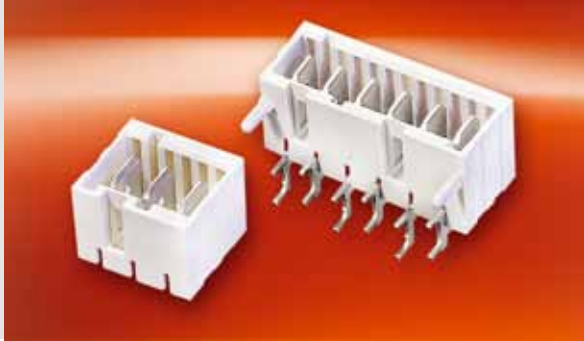

Technische Daten

Mechanisch

Raster		5 mm
Polzahl	ECO-FLEX M	2 – 12
	ECO-FLEX ML	2 – 30
	ECO-FLEX SMT	2 – 6
Anschlußart		Löttechnik
Temperaturbereich		-40 °C ... +120 °C

Elektrisch

Bemessungsstrom ²	ECO-FLEX M	16 A
	ECO-FLEX ML	10 A
Bemessungsspannung ²		250 V
Durchschlagfestigkeit		
Gehäusematerial ³		2,5 kV
Kriechstromfestigkeit ¹		CTI ≥ 400
Luft- und Kriechstrecke		≥ 4 mm
Isolationswiderstand		< 10 ⁹ Ω
Durchgangswiderstand		< 10 m Ω
Freigaben		DIN EN 61984 (IEC 61984) UL / ULC E96569

Werkstoffe

Kontakte	Flachmesser 6,3 x 0,8 mm
Isolierkörper	PA, glühdrahtbeständig, GWT 750°C nach IEC 60335-1
SMT-Messerleiste	PA, glühdrahtbeständig, GWT 750°C nach IEC 60335-1
Gehäusefarbe	natur, schwarz
Kontaktmaterial	CuZn
Kontaktoberfläche	NiSn

¹⁾ nach IEC 60664

²⁾ abhängig vom eingesetzten Gegenstecker und von der Platine

³⁾ Materialabhängig

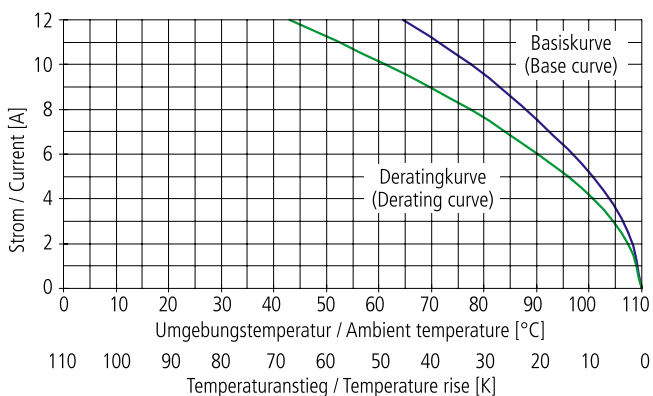

Technical data

Mechanical

Pitch		5 mm
Positions	ECO-FLEX M	2 – 12
	ECO-FLEX ML	2 – 30
	ECO-FLEX SMT	2 – 6
Termination		soldering
Temperature range		-40 °C ... +120 °C

Electrical

Current rating ²	ECO-FLEX M	16 A
	ECO-FLEX ML	10 A
Nom. voltage ²		250 V
Dielectrical strength ³		2.5 kV
Tracking resistance ¹		CTI ≥ 400
Air gap and creeping distance		≥ 4 mm
Insulation resistance		> 10 ⁹ Ω
Contact resistance		< 10 m Ω
Approved by		DIN EN 61984 (IEC 61984) UL / ULC E96569

Materials

Contacts	tabs 6.3 x 0.8 mm
Housings	PA, glow wire resistant, GWT 750°C acc. to IEC 60335-1
SMT tab connector	PA, glow wire resistant, GWT 750°C acc. to IEC 60335-1
Colour of housing	natural, black
Contact material	CuZn
Contact finishing	NiSn

¹⁾ to IEC 60664

²⁾ depending on mating connector and PC board in use

³⁾ depending on material

Derating-Kurve / Derating curve

Leiterquerschnitt: 0,75 mm² / 9-poliger Stecker
Wire size: 0.75 mm² / 9-way connector



Serie MS 9401

Messerleiste für Serien ECO-DOMO, ECO-DOMO FT, EH 688.400, EH 699

Series MS 9401

Tab connectors for series ECO-DOMO, ECO-DOMO FT, EH 688.400, EH 699

Serie MS 9401 für senkrechtes Stecken, dual-line Series MS 9401 for vertical connections, dual-line

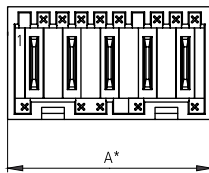
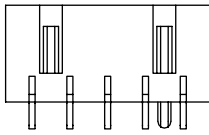

Lochbild (Bestückungsseite)
Hole pattern (component side)

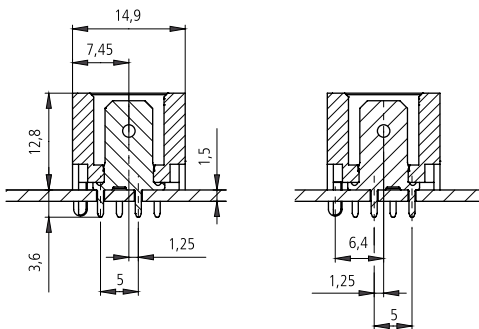
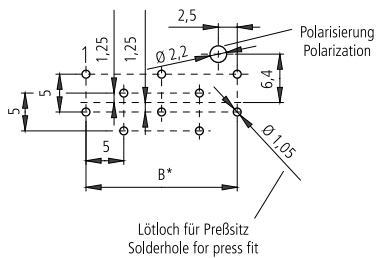

Polzahl Positions	Artikel-Nummer Part number	Abmessungen A Dimensions A	Abmessungen B Dimensions B
2	MSVV 9401 - 002 - ★	12	5
3	MSVV 9401 - 003 - ★	17	10
4	MSVV 9401 - 004 - ★	22	15
5	MSVV 9401 - 005 - ★	27	20
6	MSVV 9401 - 006 - ★	32	25
7	MSVV 9401 - 007 - ★	37	30
8	MSVV 9401 - 008 - ★	42	35
9	MSVV 9401 - 009 - ★	47	40
10	MSVV 9401 - 010 - ★	52	45
11	MSVV 9401 - 011 - ★	57	50
12	MSVV 9401 - 012 - ★	62	55

★ Bitte fügen Sie hier die Abarten-Nr. gemäß der RAST 5 Codiertabellen auf den Seiten 100 - 102 ein.
Beispiel: MSVV 9401-002-00A = 2 pol. Messerleiste mit Codierung 0A nach RAST 5.

★ Please enter here the version number as per the RAST 5 polarizing chart. See pages 100 - 102.
Example: MSVV 9401-002-00A = 2-way Tab connector with polarizing 0A to RAST 5.

Serie MS 9402

Messerleiste für Serien ECO-DOMO, ECO-DOMO FT, EH 688.400, EH 699

Series MS 9402

Tab connectors for series ECO-DOMO, ECO-DOMO FT, EH 688.400, EH 699

Serie MS 9402 für waagrechtes Stecken, Rastfenster unten

Series MS 9402 for horizontal connections, locking feature at bottom

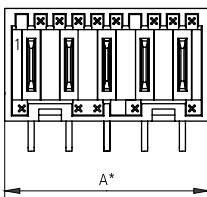
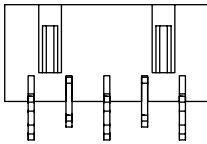

Lochbild (Bestückungsseite)
Hole pattern (component side)

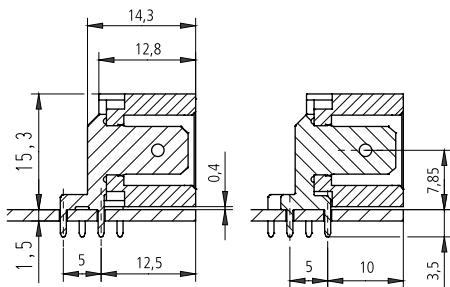
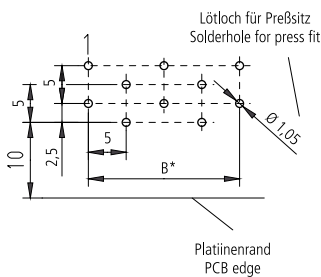

Polzahl Positions	Artikel-Nummer Part number	Abmessungen A Dimensions A	Abmessungen B Dimensions B
2	MSVV 9402 - 002 - *	12	5
3	MSVV 9402 - 003 - *	17	10
4	MSVV 9402 - 004 - *	22	15
5	MSVV 9402 - 005 - *	27	20
6	MSVV 9402 - 006 - *	32	25
7	MSVV 9402 - 007 - *	37	30
8	MSVV 9402 - 008 - *	42	35
9	MSVV 9402 - 009 - *	47	40
10	MSVV 9402 - 010 - *	52	45
11	MSVV 9402 - 011 - *	57	50
12	MSVV 9402 - 012 - *	62	55

* Bitte fügen Sie hier die Abarten-Nr. gemäß der RAST 5 Codiertabellen auf den Seiten 100 - 102 ein.
Beispiel: MSVV 9402-002-00A = 2 pol. Messerleiste mit Codierung 0A nach RAST 5.

* Please enter here the version number as per the RAST 5 polarizing chart. See pages 100 - 102.
Example: MSVV 9402-002-00A = 2-way Tab connector with polarizing 0A to RAST 5.

Serie MS 9403

Messerleiste für Serien ECO-DOMO, ECO-DOMO FT, EH 688.400, EH 699

Series MS 9403

Tab connectors for series ECO-DOMO, ECO-DOMO FT, EH 688.400, EH 699

Serie MS 9403 für waagrechtes Stecken, Rastfenster unten, erhöhte Variante für Außenrastarm
Series MS 9403 for horizontal connections, raised version, for locking feature outside at bottom

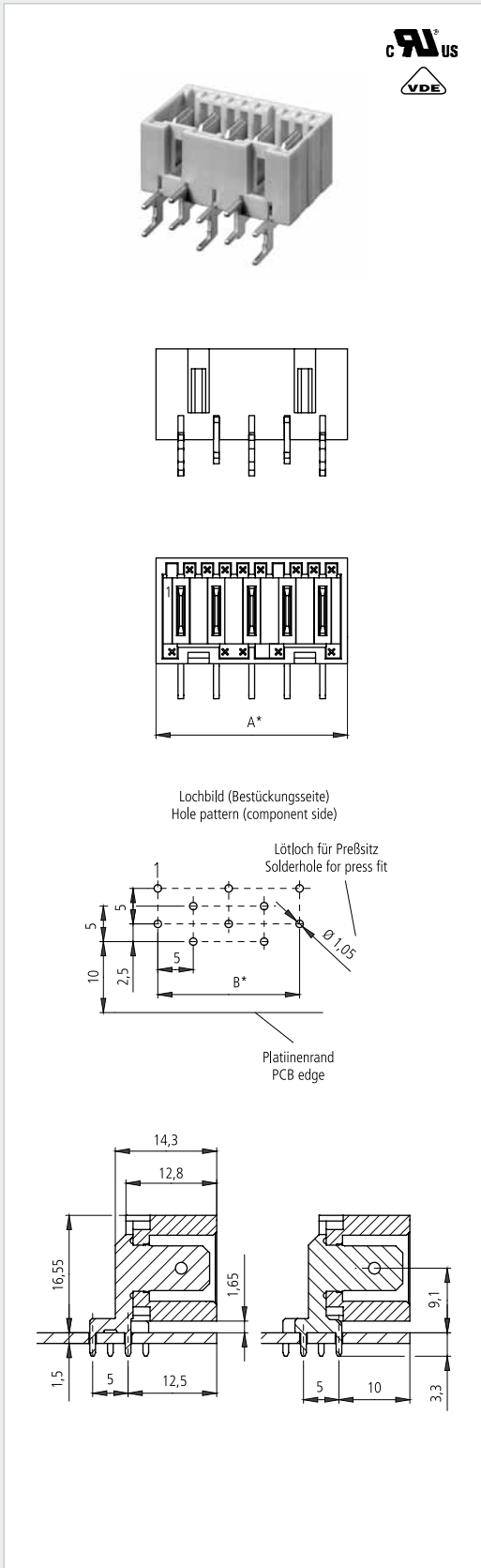

Polzahl Positions	Artikel-Nummer Part number	Abmessungen A Dimensions A	Abmessungen B Dimensions B
2	MSVV 9403 - 002 - *	12	5
3	MSVV 9403 - 003 - *	17	10
4	MSVV 9403 - 004 - *	22	15
5	MSVV 9403 - 005 - *	27	20
6	MSVV 9403 - 006 - *	32	25
7	MSVV 9403 - 007 - *	37	30
8	MSVV 9403 - 008 - *	42	35
9	MSVV 9403 - 009 - *	47	40
10	MSVV 9403 - 010 - *	52	45
11	MSVV 9403 - 011 - *	57	50
12	MSVV 9403 - 012 - *	62	55

* Bitte fügen Sie hier die Abarten-Nr. gemäß der RAST 5 Codiertabellen auf den Seiten 100 - 102 ein.
 Beispiel: MSVV 9403-002-00A = 2 pol. Messerleiste mit Codierung 0A nach RAST 5.

* Please enter here the version number as per the RAST 5 polarizing chart. See pages 100 - 102.
 Example: MSVV 9403-002-00A = 2-way Tab connector with polarizing 0A to RAST 5.

Serie MS 9404

Messerleiste für Serien ECO-DOMO, ECO-DOMO FT, EH 688.400, EH 699

Series MS 9404

Tab connectors for series ECO-DOMO, ECO-DOMO FT, EH 688.400, EH 699

Serie MS 9404 für waagerechtes Stecken, Rastfenster oben

Series MS 9404 for horizontal connections, locking feature on top

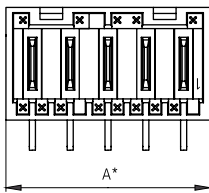
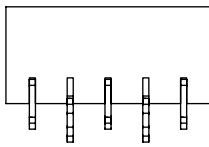

Lochbild (Bestückungsseite)
Hole pattern (component side)

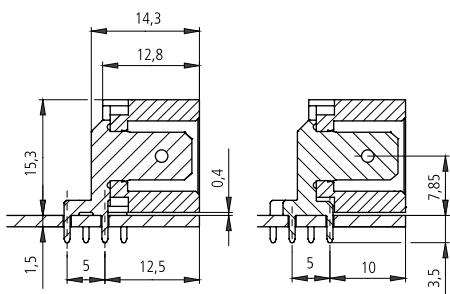
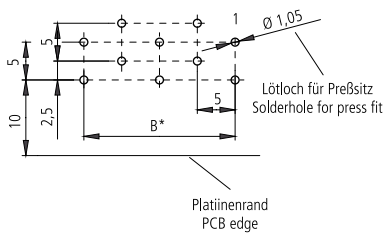

Polzahl Positions	Artikel-Nummer Part number	Abmessungen A Dimensions A	Abmessungen B Dimensions B
2	MSVV 9404 - 002 - *	12	5
3	MSVV 9404 - 003 - *	17	10
4	MSVV 9404 - 004 - *	22	15
5	MSVV 9404 - 005 - *	27	20
6	MSVV 9404 - 006 - *	32	25
7	MSVV 9404 - 007 - *	37	30
8	MSVV 9404 - 008 - *	42	35
9	MSVV 9404 - 009 - *	47	40
10	MSVV 9404 - 010 - *	52	45
11	MSVV 9404 - 011 - *	57	50
12	MSVV 9404 - 012 - *	62	55

* Bitte fügen Sie hier die Abarten-Nr. gemäß der RAST 5 Codiertabellen auf den Seiten 100 - 102 ein.
Beispiel: MSVV 9404-002-00A = 2 pol. Messerleiste mit Codierung 0A nach RAST 5.

* Please enter here the version number as per the RAST 5 polarizing chart. See pages 100 - 102.
Example: MSVV 9404-002-00A = 2-way Tab connector with polarizing 0A to RAST 5.

Serie MS 9405

Messerleiste für Serien ECO-DOMO, ECO-DOMO FT, EH 688.400, EH 699

Series MS 9405

Tab connectors for series ECO-DOMO, ECO-DOMO FT, EH 688.400, EH 699

Serie MS 9405 für senkrechtes Stecken, in-line

Series MS 9405 for vertical connections, in-line

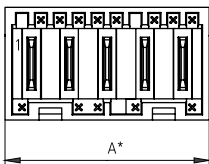
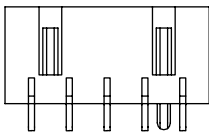

Lochbild (Bestückungsseite)
Hole pattern (component side)

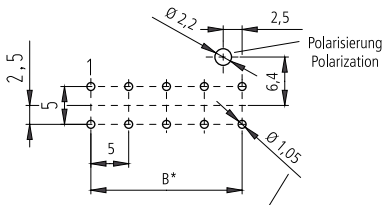

Lötloch für Preßsitz
Solderhole for press fit

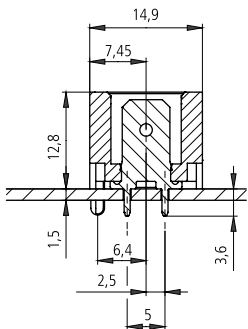

Polzahl Positions	Artikel-Nummer Part number	Abmessungen A Dimensions A	Abmessungen B Dimensions B
2	MSVV 9405 - 002 - *	12	5
3	MSVV 9405 - 003 - *	17	10
4	MSVV 9405 - 004 - *	22	15
5	MSVV 9405 - 005 - *	27	20
6	MSVV 9405 - 006 - *	32	25
7	MSVV 9405 - 007 - *	37	30
8	MSVV 9405 - 008 - *	42	35
9	MSVV 9405 - 009 - *	47	40
10	MSVV 9405 - 010 - *	52	45
11	MSVV 9405 - 011 - *	57	50
12	MSVV 9405 - 012 - *	62	55

* Bitte fügen Sie hier die Abarten-Nr. gemäß der RAST 5 Codiertabellen auf den Seiten 100 - 102 ein.

Beispiel: MSVV 9405-002-00A = 2 pol. Messerleiste mit Codierung 0A nach RAST 5.

* Please enter here the version number as per the RAST 5 polarizing chart. See pages 100 - 102.

Example: MSVV 9405-002-00A = 2-way Tab connector with polarizing 0A to RAST 5.

Serien MS 9406, 9408

Messerleisten

Series MS 9406, 9408

Tab connectors

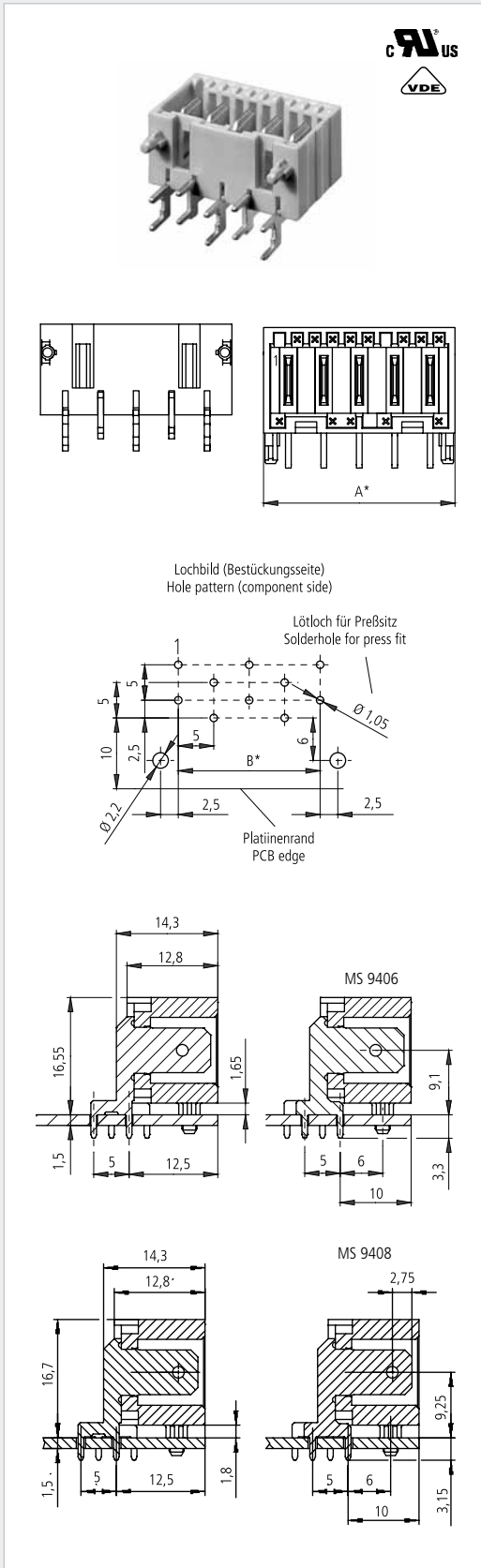

Serie MS 9406 für waagrechtes Stecken, Rastfenster unten, erhöhte Variante für Außenrastarm, mit Zapfen

Messerleiste für Serien ECO-DOMO, ECO-DOMO FT, EH 688.400, EH 699

Series MS 9406 for horizontal connections, raised version, for locking feature outside at bottom, with pegs

Tab connectors for series ECO-DOMO, ECO-DOMO FT, EH 688.400, EH 699

Polzahl Positions	Artikel-Nummer Part number	Abmessungen A Dimensions A	Abmessungen B Dimensions B
2	MSVV 9406 - 002 - *	12	5
3	MSVV 9406 - 003 - *	17	10
4	MSVV 9406 - 004 - *	22	15
5	MSVV 9406 - 005 - *	27	20
6	MSVV 9406 - 006 - *	32	25
7	MSVV 9406 - 007 - *	37	30
8	MSVV 9406 - 008 - *	42	35
9	MSVV 9406 - 009 - *	47	40
10	MSVV 9406 - 010 - *	52	45
11	MSVV 9406 - 011 - *	57	50
12	MSVV 9406 - 012 - *	62	55

Serie MS 9408 für waagrechtes Stecken, Rastfenster unten, erhöhte Variante für Außenrastarm, mit Zapfen, mit versetztem Rastloch im Kontakt

Messerleiste für EH 688

Series MS 9408 for horizontal connections, raised version, for locking feature outside at bottom, with pegs, with staggered locking feature at contact

Tab connectors for series EH 688

Polzahl Positions	Artikel-Nummer Part number	Abmessungen A Dimensions A	Abmessungen B Dimensions B
2	MSVV 9408 - 002 - *	12	5
3	MSVV 9408 - 003 - *	17	10
4	MSVV 9408 - 004 - *	22	15
5	MSVV 9408 - 005 - *	27	20
6	MSVV 9408 - 006 - *	32	25
7	MSVV 9408 - 007 - *	37	30
8	MSVV 9408 - 008 - *	42	35
9	MSVV 9408 - 009 - *	47	40
10	MSVV 9408 - 010 - *	52	45
11	MSVV 9408 - 011 - *	57	50
12	MSVV 9408 - 012 - *	62	55

* Bitte fügen Sie hier die Abarten-Nr. gemäß der RAST 5 Codiertabellen auf den Seiten 100 - 102 ein.

Beispiel: MSVV 9406-002-00A = 2 pol. Messerleiste mit Codierung 0A nach RAST 5.
MSVV 9408-002-00A = 2 pol. Messerleiste mit Codierung 0A nach RAST 5.

* Please enter here the version number as per the RAST 5 polarizing chart. See pages 100 - 102.

Example: MSVV 9406-002-00A = 2-way Tab connector with polarizing 0A to RAST 5.
MSVV 9408-002-00A = 2-way Tab connector with polarizing 0A to RAST 5.

Serie MS 9407

Messerleiste für Serie EH 688

Series MS 9407

Tab connectors for series EH 688

Serie MS 9407 für senkrecht Stecken, mit versetztem Rastloch im Kontakt Series MS 9407 for vertical connections, with staggered locking feature at contact

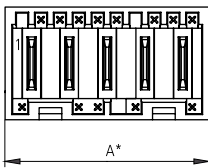
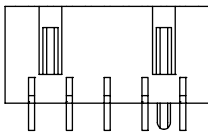

Lochbild (Bestückungsseite)
Hole pattern (component side)

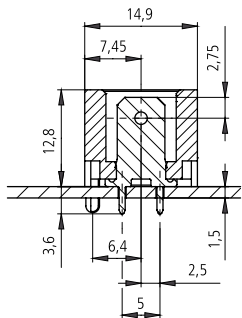
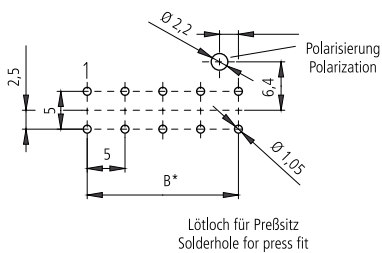

Polzahl Positions	Artikel-Nummer Part number	Abmessungen A Dimensions A	Abmessungen B Dimensions B
2	MSVV 9407 - 002 - *	12	5
3	MSVV 9407 - 003 - *	17	10
4	MSVV 9407 - 004 - *	22	15
5	MSVV 9407 - 005 - *	27	20
6	MSVV 9407 - 006 - *	32	25
7	MSVV 9407 - 007 - *	37	30
8	MSVV 9407 - 008 - *	42	35
9	MSVV 9407 - 009 - *	47	40
10	MSVV 9407 - 010 - *	52	45
11	MSVV 9407 - 011 - *	57	50
12	MSVV 9407 - 012 - *	62	55

* Bitte fügen Sie hier die Abarten-Nr. gemäß der RAST 5 Codiertabellen auf den Seiten 100 - 102 ein.
Beispiel: MSVV 9407-002-00A = 2 pol. Messerleiste mit Codierung 0A nach RAST 5.

* Please enter here the version number as per the RAST 5 polarizing chart. See pages 100 - 102.
Example: MSVV 9407-002-00A = 2-way Tab connector with polarizing 0A to RAST 5.

Serie MS 9481, ECO-FLEX SMT

Messerleiste für Serien ECO-DOMO, ECO-DOMO FT

Series MS 9481, ECO-FLEX SMT

Tab connectors for series ECO-DOMO, ECO-DOMO FT

Serie MS 9481 für senkrechtes Stecken Series MS 9481 for vertical connections

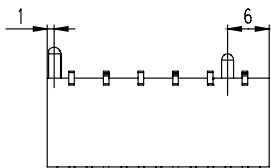
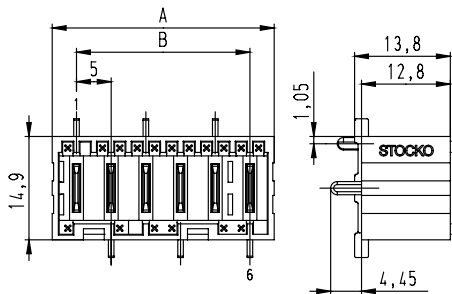

Platinenlayout
PCB layout

Lötpad hier beginnend
Soldering pad count to begin here

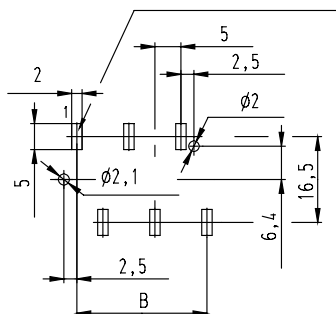

Polzahl Positions	Artikel-Nummer Part number	Abmessungen A Dimensions A	Abmessungen B Dimensions B
2	MSVV 9481 - 002 - ★	12	5
3	MSVV 9481 - 003 - ★	17	10
4	MSVV 9481 - 004 - ★	22	15
5	MSVV 9481 - 005 - ★	27	20
6	MSVV 9481 - 006 - ★	32	25

★ Bitte fügen Sie hier die Abarten-Nr. gemäß der RAST 5 Codiertabellen auf den Seiten 100 - 102 ein.
Beispiel: MSVV 9481-002-00A = 2 pol. Messerleiste mit Codierung 0A nach RAST 5.

★ Please enter here the version number as per the RAST 5 polarizing chart. See pages 100 - 102.
Example: MSVV 9481-002-00A = 2-way Tab connector with polarizing 0A to RAST 5.

Serie 9410 ECO-FLEX ML

Messerleiste mit Trennwänden, Label optional

Serie 9410 ECO-FLEX ML

Tab connector with separating plate, label optional

Serie 9411 für senkrecht Stecken, dual-line Series 9411 for vertical connections, dual-line

Polzahl Positions	Artikel-Nummer Part number	Abmessungen A Dimensions A
3	MS 9411 - 03 - *	17,0
12	MS 9411 - 12 - *	69,5
13	MS 9411 - 13 - *	69,5

Serie 9412 für waagrecht Stecken, dual-line Series 9412 for horizontal connections, dual-line

Polzahl Positions	Artikel-Nummer Part number	Abmessungen A Dimensions A
10	MS 9412 - 10 - *	62,0
13	MS 9412 - 13 - *	77,0

Serie 9413 für waagrecht Stecken, dual-line, erhöhte Version Series 9413 for horizontal connections, dual-line, higher version

Polzahl Positions	Artikel-Nummer Part number	Abmessungen A Dimensions A
4	MS 9413 - 04 - *	24,5
5	MS 9413 - 05 - *	29,5
8	MS 9413 - 08 - *	49,5
9	MS 9413 - 09 - *	57,0
10	MS 9413 - 10 - *	62,0
12	MS 9413 - 12 - *	69,5
13	MS 9413 - 13 - *	79,5
14	MS 9413 - 14 - *	84,5
15	MS 9413 - 15 - *	89,5
16	MS 9413 - 16 - *	92,0
17	MS 9413 - 17 - *	102,0
18	MS 9413 - 18 - *	112,0
19	MS 9413 - 19 - *	109,5
20	MS 9413 - 20 - *	119,5

- * Weitere Polzahlen und Abarten auf Anfrage
- * Further positions and modification on request

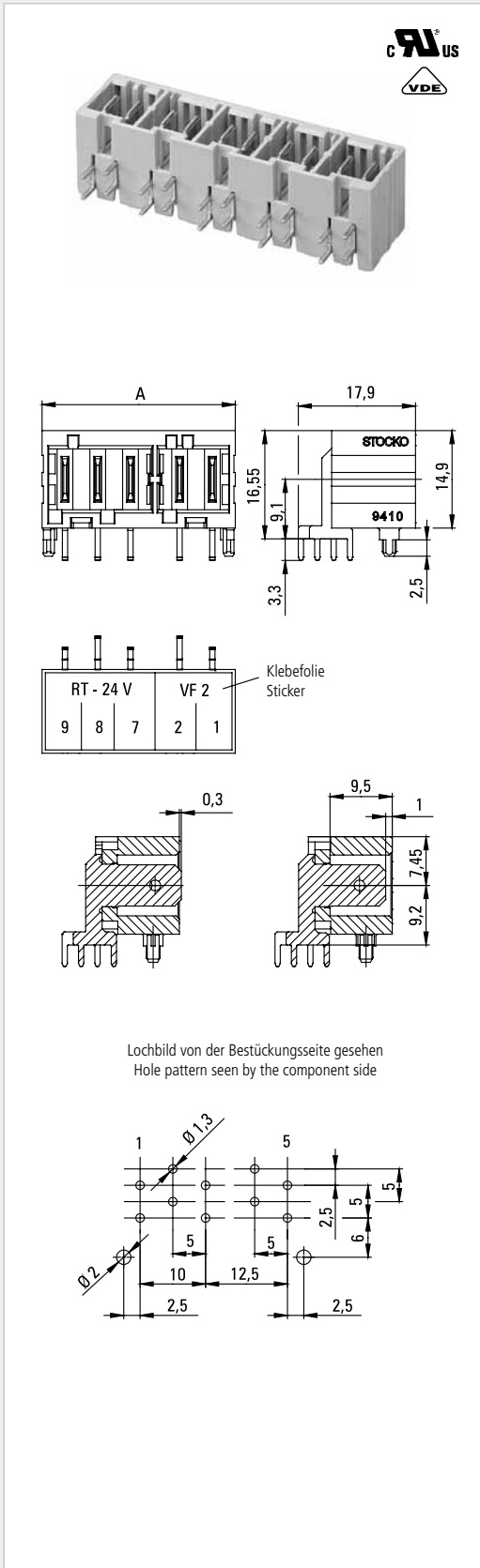

Serie 9420 ECO-FLEX ML

Messerleiste mit Trennwänden, Label optional

Serie 9420 ECO-FLEX ML

Tab connector with separating plate, label optional

Serie 9421 für senkrecht Stecken, Brückenleiter als Null- und / oder Schutzleiter optional Series 9421 for vertical connections, neutral and / or grounded bridging connectors optional

Polzahl Positions	Artikel-Nummer Part number	Abmessungen A Dimensions A
6	MS 9421 - 06 - *	32,0
8	MS 9421 - 08 - *	42,0
10	MS 9421 - 10 - *	57,0
11	MS 9421 - 11 - *	57,0
17	MS 9421 - 17 - *	89,5
18	MS 9421 - 18 - *	92,0
21	MS 9421 - 21 - *	112,0
22	MS 9421 - 22 - *	114,5
28	MS 9421 - 28 - *	149,5

Serie 9422 für waagrecht Stecken Series 9422 for horizontal connections

Polzahl Positions	Artikel-Nummer Part number	Abmessungen A Dimensions A
4	MS 9422 - 04 - *	24,5
10	MS 9422 - 10 - *	62,0
11	MS 9422 - 11 - *	67,0
12	MS 9422 - 12 - *	69,5
17	MS 9422 - 17 - *	97,0
25	MS 9422 - 25 - *	142,0

Serie 9423 für waagrecht Stecken, dual-line, erhöhte Version Series 9423 for horizontal connections, dual-line, higher version

Polzahl Positions	Artikel-Nummer Part number	Abmessungen A Dimensions A
6	MS 9423 - 06 - *	32,0
16	MS 9423 - 16 - *	84,5
18	MS 9423 - 18 - *	104,5
22	MS 9423 - 22 - *	132,0

- * Weitere Polzahlen und Abarten auf Anfrage
- * Further positions and modification on request

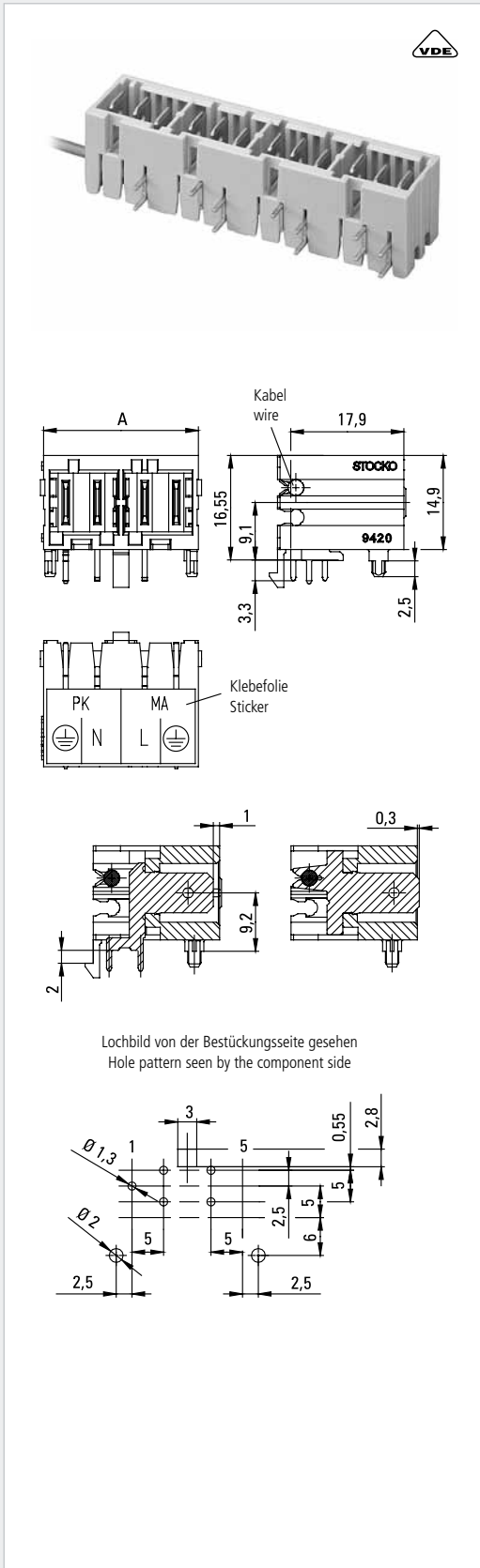

»Steckverbindersystem MTL 2 S« Connector system MTL 2 S

Systembeschreibung

- Messerleiste nach RAST 5
- Ausführung in vertikaler oder horizontaler Steckrichtung zur Leiterplatte
- Erhöhte horizontale Ausführung auch geeignet für Steckverbinder mit Außenrastarm
- Kontaktausführung in dual- oder in-line
- Individuelle Positionierung und Codierung
- Positionierzapfen optional

Description of system

- Tab connectors in accordance with RAST 5
- Versions for vertical or horizontal PC board assembly
- Higher horizontal version also suitable for connectors with locking features outside
- For in-line or dual-line hole patterns
- Individual polarizing and positioning possible
- Pegs optional

Bestellbeispiel

RAST 5 Messerleisten

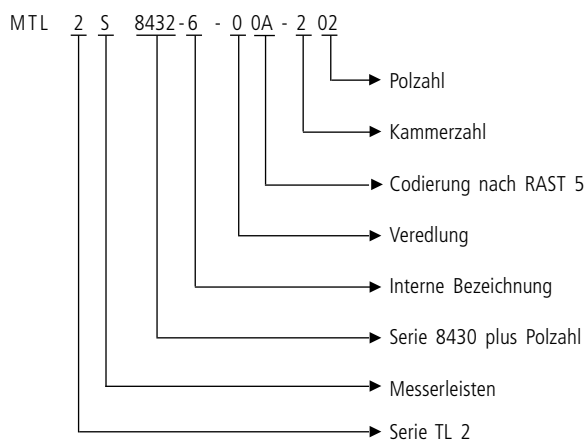

Example for ordering

RAST 5 Tab connectors

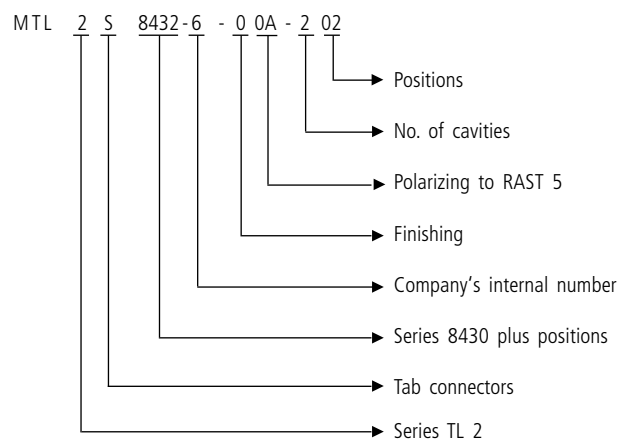

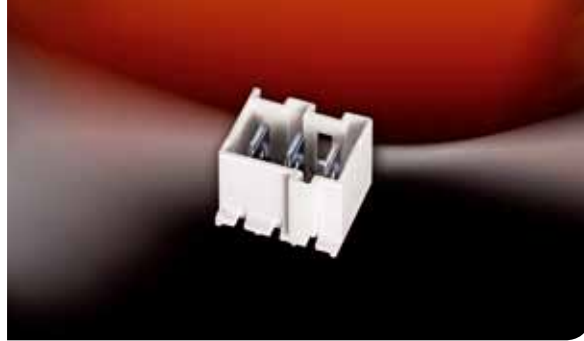
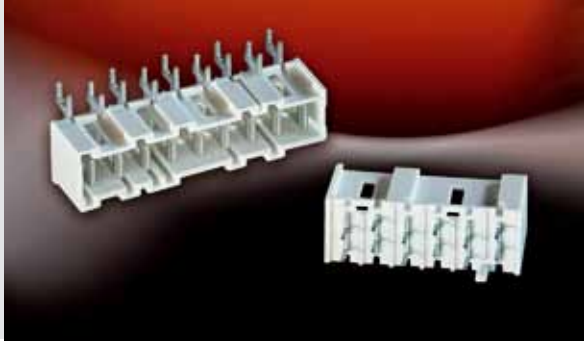

Technische Daten

Mechanisch

Raster	5 mm
Polzahl	2 – 12
Anschlußart	Löttechnik
Temperaturbereich	-40 °C ... +110 °C

Elektrisch

Bemessungsstrom ²	16 A
Bemessungsspannung ²	400 V
Durchschlagfestigkeit	
Gehäusematerial	2,5 kV
Kriechstromfestigkeit ¹	CTI ≥ 275
Luft- und Kriechstrecke	≥ 4 mm
Isolationswiderstand	≥ 10 ⁹ Ω
Durchgangswiderstand	≤ 5 m Ω
Freigaben	DIN EN 61984 (IEC 61984) UL / ULC E96569

Werkstoffe

Kontakte	Flachmesser 6,3 x 0,8 mm
Isolierkörper	PBT
Gehäusefarbe	natur
Kontaktmaterial	CuZn
Kontaktoberfläche	NiSn

¹⁾ nach IEC 60664

²⁾ abhängig vom eingesetzten Gegenstecker

Technical data

Mechanical

Pitch	5 mm
Positions	2 – 12
Termination	soldering
Temperature range	-40 °C ... +110 °C

Electrical

Current rating ²	16 A
Nom. voltage ²	400 V
Dielectrical strength	2.5 kV
Tracking resistance ¹	CTI ≥ 275
Air gap and creeping distance	≥ 4 mm
Insulation resistance	≥ 10 ⁹ Ω
Contact resistance	≤ 5 m Ω
Approved by	DIN EN 61984 (IEC 61984) UL / ULC E96569

Materials

Contacts	tabs 6.3 x 0.8 mm
Housings	PBT
Colour of housing	natural
Contact material	CuZn
Contact finishing	NiSn

¹⁾ to IEC 60664

²⁾ depending on mating connector in use



Serie MTL 2 S 8430

Messerleiste für Serien ECO-DOMO, ECO-DOMO FT, EH 688.400, EH 699

Series MTL 2 S 8430

Tab connectors for series ECO-DOMO, ECO-DOMO FT, EH 688.400, EH 699

Serie MTL 2 S 8430 für waagrechtes Stecken Series MTL 2 S 8430 for horizontal connections

Polzahl Positions	Artikel-Nummer Part number	Abmessungen A Dimensions A	Abmessungen B Dimensions B
2	MTL 2 S 8432 - 6 - 0 * - 202	12	5
3	MTL 2 S 8433 - 6 - 0 * - 303	17	10
4	MTL 2 S 8434 - 6 - 0 * - 404	22	15
5	MTL 2 S 8435 - 6 - 0 * - 505	27	20
6	MTL 2 S 8436 - 6 - 0 * - 606	32	25
7	MTL 2 S 8437 - 6 - 0 * - 707	37	30
8	MTL 2 S 8438 - 6 - 0 * - 808	42	35
9	MTL 2 S 8439 - 6 - 0 * - 909	47	40
10	MTL 2 S 8440 - 6 - 0 * - 1010	52	45
11	MTL 2 S 8441 - 6 - 0 * - 1111	57	50
12	MTL 2 S 8442 - 6 - 0 * - 1212	62	55

* Bitte fügen Sie hier die Abarten-Nummer gemäß der RAST 5 Codiertabellen auf den Seiten 100 - 102 ein.
Beispiel: MTL 2 S 8432 - 6 - 00A - 202 2polige Messerleiste mit Codierung 0A nach RAST 5.

* Please enter here the version number as per the RAST 5 polarizing chart. See pages 100 - 102.
Example: MTL 2 S 8432 - 6 - 00A - 202 2-way tab connector with polarizing 0A to RAST 5.

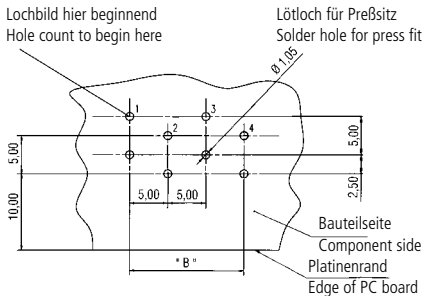
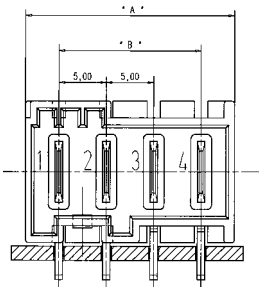

n = Polzahl / Positions
R = 5 mm
B = (n-1) x R
A = (n-1) x R + 7 mm

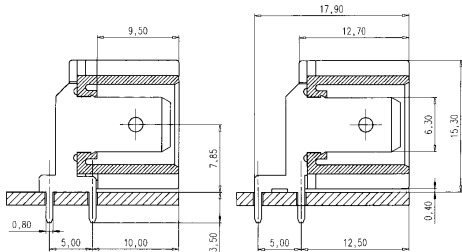

liegend versetztes Raster
horizontal, staggered pin arrangement

Serie MTL 2 S 8580

Messerleiste für Serien ECO-DOMO, ECO-DOMO FT, EH 688.400, EH 699

Series MTL 2 S 8580

Tab connectors for series ECO-DOMO, ECO-DOMO FT, EH 688.400, EH 699

Serie MTL 2 S 8580 für waagerechtes Stecken, erhöhte Version, für Außenverrastung

Series MTL 2 S 8580 for horizontal connections, raised version, for locking feature outside

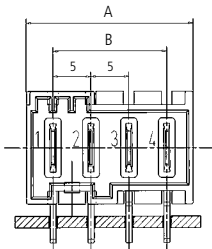

$B = (n-1) \times R$
 $A = (n-1) \times R + 7 \text{ mm}$
 $n = \text{Polzahl / Positions}$
 $R = 5 \text{ mm}$

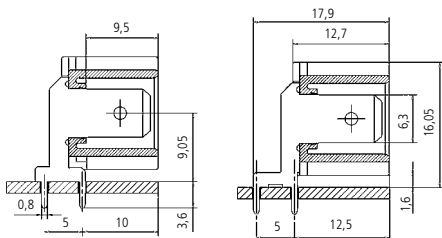
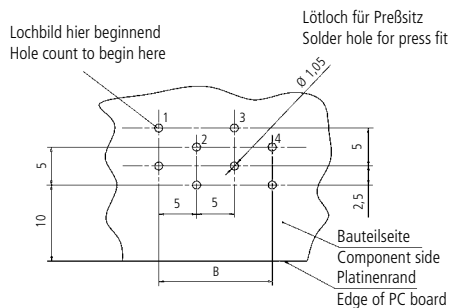

Polzahl Positions	Artikel-Nummer Part number	Abmessungen A Dimensions A	Abmessungen B Dimensions B
2	MTL 2 S 8582 - 6 - 0 * - 202	12	5
3	MTL 2 S 8583 - 6 - 0 * - 303	17	10
4	MTL 2 S 8584 - 6 - 0 * - 404	22	15
5	MTL 2 S 8585 - 6 - 0 * - 505	27	20
6	MTL 2 S 8586 - 6 - 0 * - 606	32	25
7	MTL 2 S 8587 - 6 - 0 * - 707	37	30
8	MTL 2 S 8588 - 6 - 0 * - 808	42	35
9	MTL 2 S 8589 - 6 - 0 * - 909	47	40
10	MTL 2 S 8590 - 6 - 0 * - 1010	52	45
11	MTL 2 S 8591 - 6 - 0 * - 1111	57	50
12	MTL 2 S 8592 - 6 - 0 * - 1212	62	55

* Bitte fügen Sie hier die Abarten-Nummer gemäß der RAST 5 Codiertabellen auf den Seiten 100 - 102 ein.
 Beispiel: MTL 2 S 8582 - 6 - 00A - 202 2polige Messerleiste mit Codierung 0A nach RAST 5.

* Please enter here the version number as per the RAST 5 polarizing chart. See pages 100 - 102.
 Example: MTL 2 S 8582 - 6 - 00A - 202 2-way tab connector with polarizing 0A to RAST 5.

Serie MTL 2 S 8600

Messerleiste für Serien ECO-DOMO, ECO-DOMO FT, EH 699, EH 688.400

Series MTL 2 S 8600

Tab connectors for series ECO-DOMO, ECO-DOMO FT, EH 699, EH 688.400

Serie MTL 2 S 8600 für waagerechtes Stecken, Verrastung oben

Series MTL 2 S 8600 for horizontal connections, locking feature on top

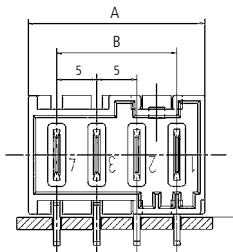

$B = (n-1) \times R$
 $A = (n-1) \times R + 7 \text{ mm}$
 $n = \text{Polzahl / Positions}$
 $R = 5 \text{ mm}$

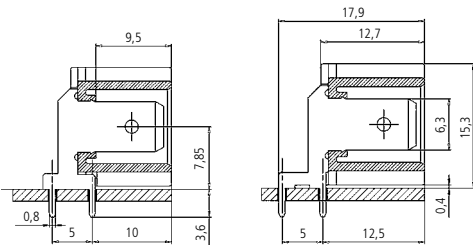
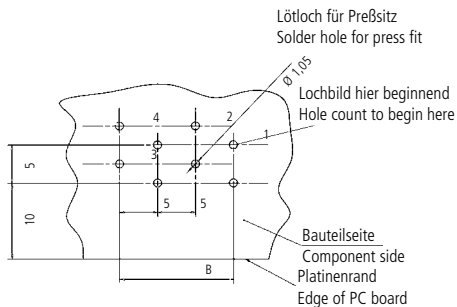

Polzahl Positions	Artikel-Nummer Part number	Abmessungen A Dimensions A	Abmessungen B Dimensions B
2	MTL 2 S 8602 - 6 - 0 * - 202	12	5
3	MTL 2 S 8603 - 6 - 0 * - 303	17	10
4	MTL 2 S 8604 - 6 - 0 * - 404	22	15
5	MTL 2 S 8605 - 6 - 0 * - 505	27	20
6	MTL 2 S 8606 - 6 - 0 * - 606	32	25
7	MTL 2 S 8607 - 6 - 0 * - 707	37	30
8	MTL 2 S 8608 - 6 - 0 * - 808	42	35
9	MTL 2 S 8609 - 6 - 0 * - 909	47	40
10	MTL 2 S 8610 - 6 - 0 * - 1010	52	45
11	MTL 2 S 8611 - 6 - 0 * - 1111	57	50
12	MTL 2 S 8612 - 6 - 0 * - 1212	62	55

* Bitte fügen Sie hier die Abarten-Nummer gemäß der RAST 5 Codiertabellen auf den Seiten 100 - 102 ein.
 Beispiel: MTL 2 S 8602 - 6 - 00A - 202 2polige Messerleiste mit Codierung 0A nach RAST 5.

* Please enter here the version number as per the RAST 5 polarizing chart. See pages 100 - 102.
 Example: MTL 2 S 8602 - 6 - 00A - 202 2-way tab connector with polarizing 0A to RAST 5.

Serie MTL 2 S 8470

Messerleiste für Serien ECO-DOMO, ECO-DOMO FT, EH 699, EH 688.400

Series MTL 2 S 8470

Tab connectors for series ECO-DOMO, ECO-DOMO FT, EH 699, EH 688.400

Serie MTL 2 S 8470 für senkrecht Stecken Series MTL 2 S 8470 for vertical connections

Polzahl Positions	Artikel-Nummer Part number	Abmessungen A Dimensions A	Abmessungen B Dimensions B
2	MTL 2 S 8472 - 6 - 0 * - 202	12	5
3	MTL 2 S 8473 - 6 - 0 * - 303	17	10
4	MTL 2 S 8474 - 6 - 0 * - 404	22	15
5	MTL 2 S 8475 - 6 - 0 * - 505	27	20
6	MTL 2 S 8476 - 6 - 0 * - 606	32	25
7	MTL 2 S 8477 - 6 - 0 * - 707	37	30
8	MTL 2 S 8478 - 6 - 0 * - 808	42	35
9	MTL 2 S 8479 - 6 - 0 * - 909	47	40
10	MTL 2 S 8480 - 6 - 0 * - 1010	52	45
11	MTL 2 S 8481 - 6 - 0 * - 1111	57	50
12	MTL 2 S 8482 - 6 - 0 * - 1212	62	55

* Bitte fügen Sie hier die Abarten-Nummer gemäß der RAST 5 Codiertabellen auf den Seiten 100 - 102 ein.
Beispiel: MTL 2 S 8472 - 6 - 00A - 202 2polige Messerleiste mit Codierung 0A nach RAST 5.

* Please enter here the version number as per the RAST 5 polarizing chart. See pages 100 - 102.
Example: MTL 2 S 8472 - 6 - 00A - 202 2-way tab connector with polarizing 0A to RAST 5.

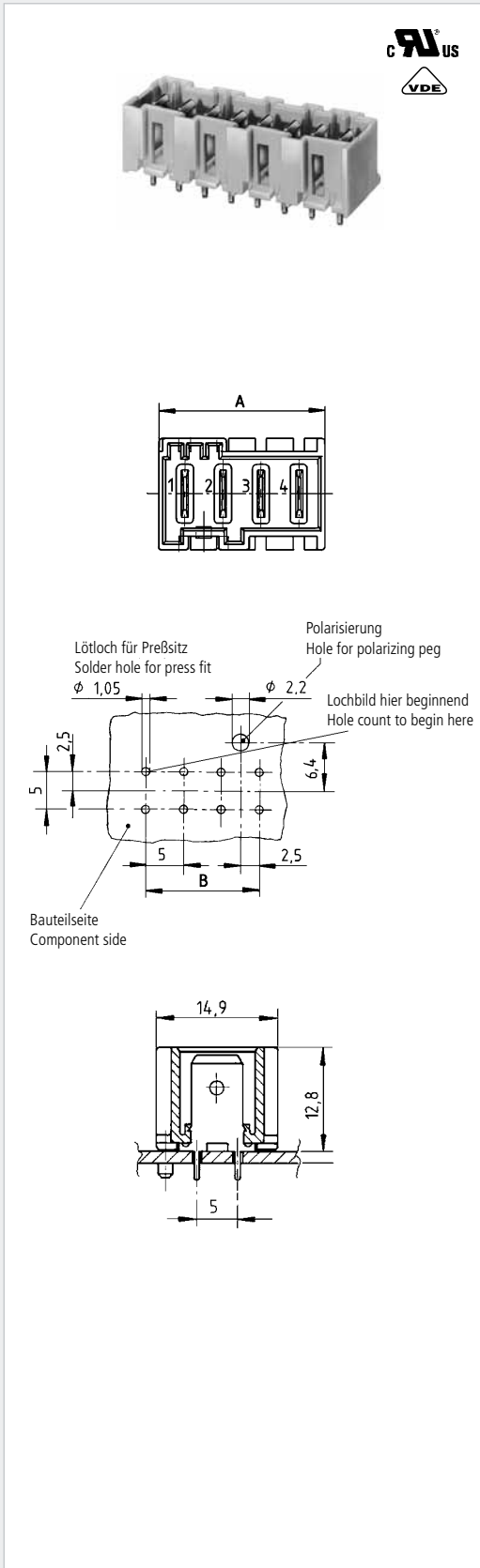

Serie MTL 2 S 8450

Messerleiste für Serien ECO-DOMO, ECO-DOMO FT, EH 699, EH 688.400

Series MTL 2 S 8450

Tab connectors for series ECO-DOMO, ECO-DOMO FT, EH 699, EH 688.400

Serie MTL 2 S 8450 für senkrechtes Stecken Series MTL 2 S 8450 for vertical connections

Polzahl Positions	Artikel-Nummer Part number	Abmessungen A Dimensions A	Abmessungen B Dimensions B
2	MTL 2 S 8452 - 6 - 0 * - 202	12	5
3	MTL 2 S 8453 - 6 - 0 * - 303	17	10
4	MTL 2 S 8454 - 6 - 0 * - 404	22	15
5	MTL 2 S 8455 - 6 - 0 * - 505	27	20
6	MTL 2 S 8456 - 6 - 0 * - 606	32	25
7	MTL 2 S 8457 - 6 - 0 * - 707	37	30
8	MTL 2 S 8458 - 6 - 0 * - 808	42	35
9	MTL 2 S 8459 - 6 - 0 * - 909	47	40
10	MTL 2 S 8460 - 6 - 0 * - 1010	52	45
11	MTL 2 S 8461 - 6 - 0 * - 1111	57	50
12	MTL 2 S 8462 - 6 - 0 * - 1212	62	55

* Bitte fügen Sie hier die Abarten-Nummer gemäß der RAST 5 Codiertabellen auf den Seiten 100 - 102 ein.
Beispiel: MTL 2 S 8452 - 6 - 00A - 202 2polige Messerleiste mit Codierung 0A nach RAST 5.

* Please enter here the version number as per the RAST 5 polarizing chart. See pages 100 - 102.
Example: MTL 2 S 8452 - 6 - 00A - 202 2-way tab connector with polarizing 0A to RAST 5.

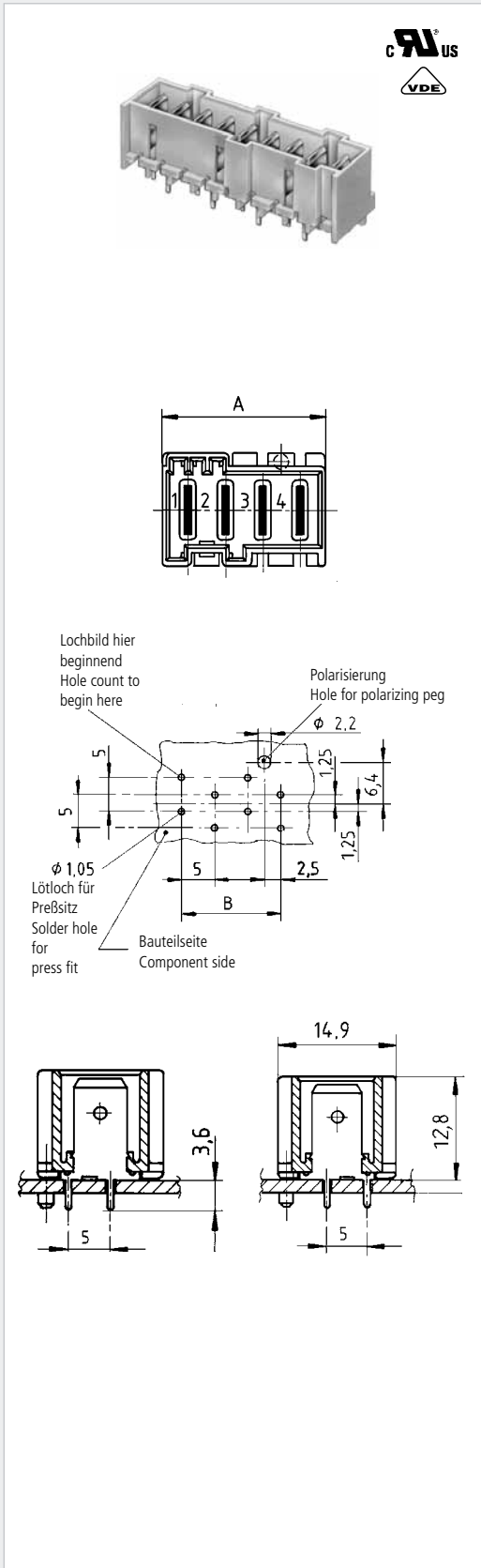

Serie MTL 2 S 7770

Messerleiste für Serie EH 688

Series MTL 2 S 7770

Tab connectors for series EH 688

Serie MTL 2 S 7770 für senkrechtes Stecken Series MTL 2 S 7770 for vertical connections

Polzahl Positions	Artikel-Nummer Part number	Abmessungen A Dimensions A	Abmessungen B Dimensions B
2	MTL 2 S 7772 - 6 - 0 * - 202	12	5
3	MTL 2 S 7773 - 6 - 0 * - 303	17	10
4	MTL 2 S 7774 - 6 - 0 * - 404	22	15
5	MTL 2 S 7775 - 6 - 0 * - 505	27	20
6	MTL 2 S 7776 - 6 - 0 * - 606	32	25
7	MTL 2 S 7777 - 6 - 0 * - 707	37	30
8	MTL 2 S 7778 - 6 - 0 * - 808	42	35
9	MTL 2 S 7779 - 6 - 0 * - 909	47	40
10	MTL 2 S 7780 - 6 - 0 * - 1010	52	45
11	MTL 2 S 7781 - 6 - 0 * - 1111	57	50
12	MTL 2 S 7782 - 6 - 0 * - 1212	62	55

* Bitte fügen Sie hier die Abarten-Nummer gemäß der RAST 5 Codiertabellen auf den Seiten 100 - 102 ein.
Beispiel: MTL 2 S 7772 - 6 - 00A - 202 2polige Messerleiste mit Codierung 0A nach RAST 5.

* Please enter here the version number as per the RAST 5 polarizing chart. See pages 100 - 102.
Example: MTL 2 S 7772 - 6 - 00A - 202 2-way tab connector with polarizing 0A to RAST 5.

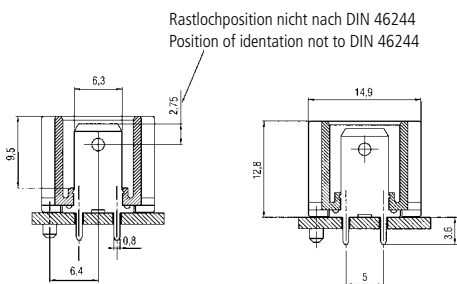
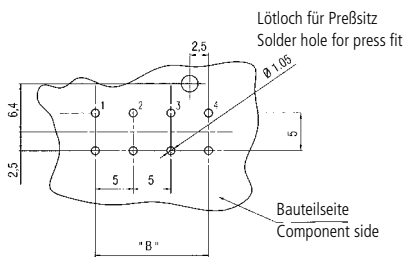
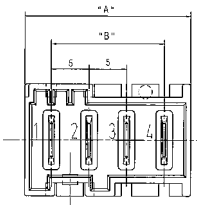

n = Polzahl / Positions
R = 5 mm
B = (n-1) x R
A = (n-1) x R + 7 mm

»Steckverbindersystem RAST 5 Crimp« Connector system RAST 5 Crimp

Systembeschreibung

Gehäuse

- Steckverbinder mit Crimpanschluss
- Gehäuseabmessungen entsprechend der Weißgeräte-Spezifikation RAST 5
- Unterschiedliche Codierungen nach RAST 5
- Indirektstecker mit Innenverrastung
- Leiterabgang 90° / 180°

Messerleiste ECO-DOMO PM

- Als fliegende Kupplung oder Schottwanddurchführung

Description of system

Housings

- Housing with crimp connection
- Dimensions of housing in accordance with RAST 5 standard specification for domestic appliance
- Different polarizing features
- Indirect connector with inside locking device
- Cable exit 90° / 180°

Tab connector ECO-DOMO PM

- For flying lead or panel mounting

Bestellbeispiel

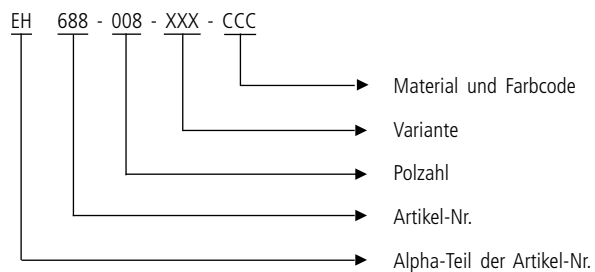

Example for ordering

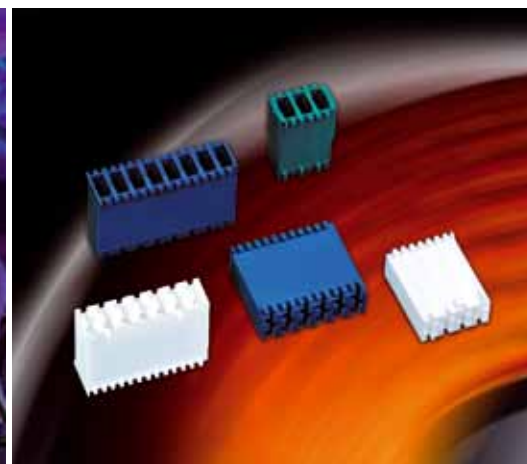
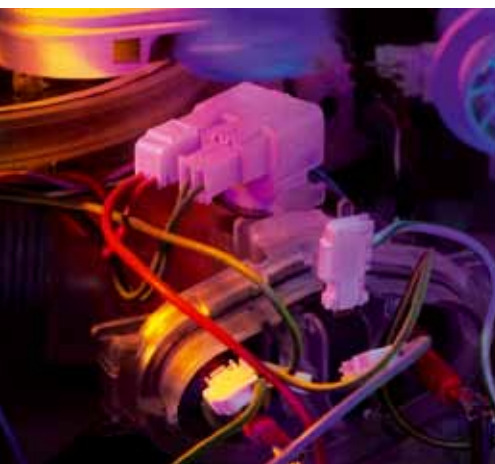
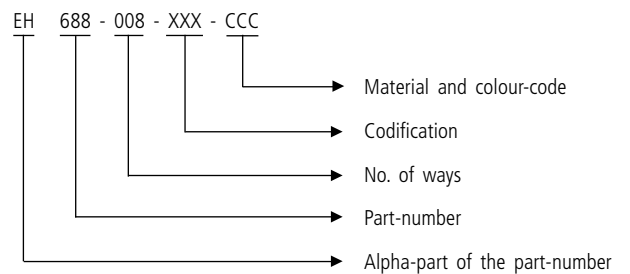



Technische Daten

Mechanisch

Raster		5 mm
Polzahl	EH 699	2 – 5
	EH 688	1 – 8
	ED PM	2 – 10
Verrastung		Innenverrastung 6,3 FSH
Anschlußart		Crimptechnik
Leiterquerschnitt		0.5 – 1,5 mm ²
Isolations-Ø		max. 3,3 mm
Temperaturbereich		-40 °C ... +120 °C

Elektrisch

Bemessungsstrom		16 A
Bemessungsspannung		250 / 400 V
Durchschlagfestigkeit		≥ 3,0 kV
Gehäusematerial		≥ 3 mm
Luftstrecke		≥ 3 mm
Kriechstrecke		≥ 3 mm
Freigaben	EH 688 / EH 699	DIN EN 61984 (IEC 61984)
	EH 688	UL / ULC E96569
	EH 699	UL E306640

Werkstoffe

Kontakte	ECO-DOMO PM	CuZn
Kontaktoberfläche		Sn
Isolierkörper		PA, glühdrahtbeständig, GWT 750°C nach IEC 60335-1
Gehäusefarbe		natur weitere Farben auf Anfrage

Technical data

Mechanical

Pitch		5 mm
Positions	EH 699	2 – 5
	EH 688	1 – 8
	ED PM	2 – 10
Locking features		inside 6.3 FSH
Termination		Crimp technology
Wire size		0.5 – 1.5 mm ²
Insulation-Ø		max. 3.3 mm
Temperature range		-40 °C ... +120 °C

Electrical

Current rating		16 A
Nom. voltage		250 / 400 V
Dielectrical strength		≥ 3.0 kV
Air gap		≥ 3 mm
Creeping distance		≥ 3 mm
Approved by	EH 688 / EH 699	DIN EN 61984 (IEC 61984)
	EH 688	UL / ULC E96569
	EH 699	UL E306640

Materials

Contact	ECO-DOMO PM	CuZn
Contact finishing		Sn
Housing		PA, glow wire resistant, GWT 750°C acc. to IEC 60335-1
Colour of housing		natural other colours on request

Derating-Kurven EH 688 / Derating curves EH 688

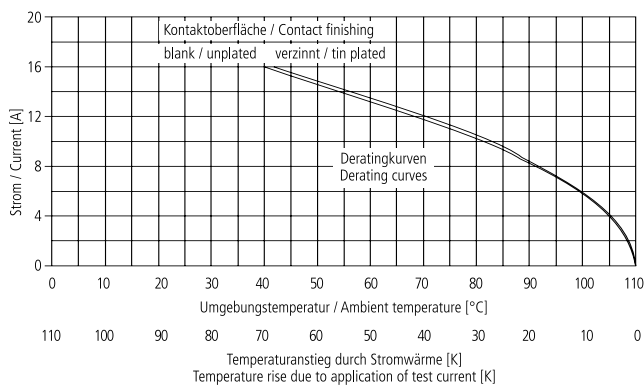

Derating-Kurve / Derating curve

Derating-Kurven EH 688 / Derating curves EH 688



Serie EH 688, RAST 5 Crimp

Gehäuse

Series EH 688, RAST 5 Crimp

Housings

Serie EH 688 für RAST 5 Komponenten sowie für die Serien MTL 2 S 7770, MS 9407 und MS 9408
Series EH 688 for RAST 5 components and series MTL 2 S 7770, MS 9407 and MS 9408

Gehäuse
Housings

Polzahl Positions	Artikel-Nummer Part number	Abmessungen A Dimensions A	Abmessungen B Dimensions B
1	EH 688 - 001 - 0 *	5	
2	EH 688 - 002 - 0 *	10	5
3	EH 688 - 003 - 0 *	15	10
4	EH 688 - 004 - 0 *	20	15
5	EH 688 - 005 - 0 *	25	20
6	EH 688 - 006 - 0 *	30	25
7	EH 688 - 007 - 0 *	35	30
8	EH 688 - 008 - 0 *	40	35

- * Vorzugstypen siehe Seite 104. Weitere Codierungen auf Anfrage.
- * Preferential versions see page 104. More polarizing on request.

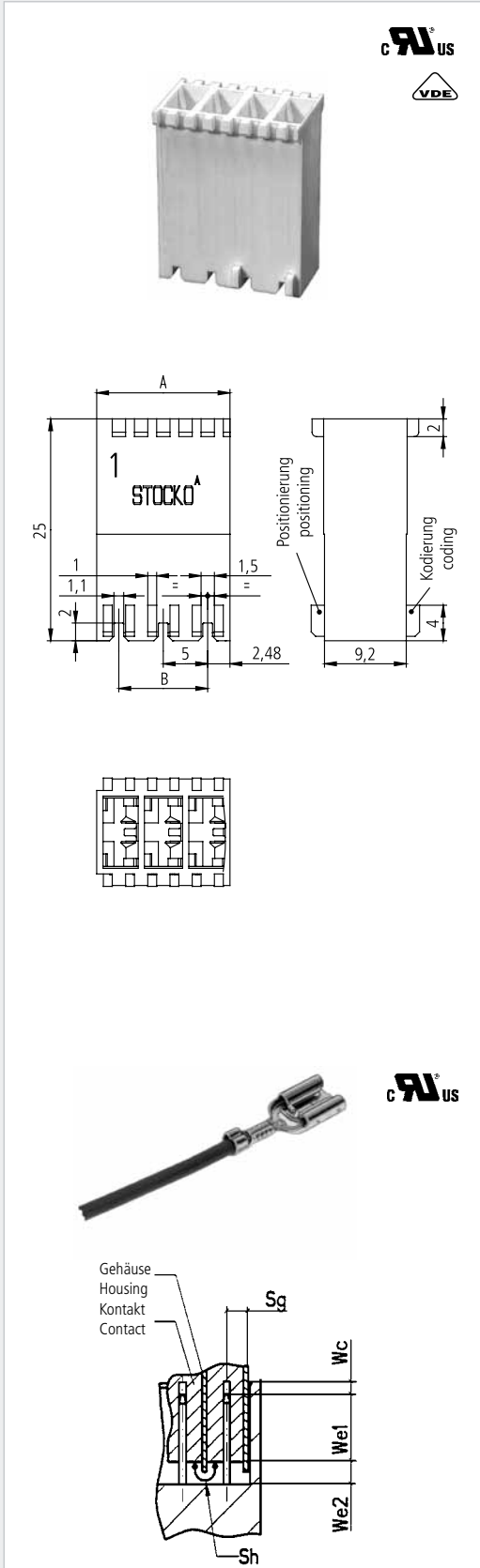

Kontakte
Contacts

Artikel-Nummer Part number	Leiterquerschnitt Wire size	Material Material	Oberfläche Finishing
RSB 8178.108 F 6,3 - 1 *	0,5-1 mm ²	CuZn	blank, verzinkt / unplated, tin plated
RSB 8178.258 F 6,3 - 2,5 *	>1-2,5 mm ²	CuZn	blank, verzinkt / unplated, tin plated
RSB 8178.308 F 6,3 - 3 *	2 x 1,5 mm ²	CuZn	blank, verzinkt / unplated, tin plated

* UL / ULC E96569

Serie EH 688.400, RAST 5 Crimp

Gehäuse

Series EH 688.400, RAST 5 Crimp

Housings

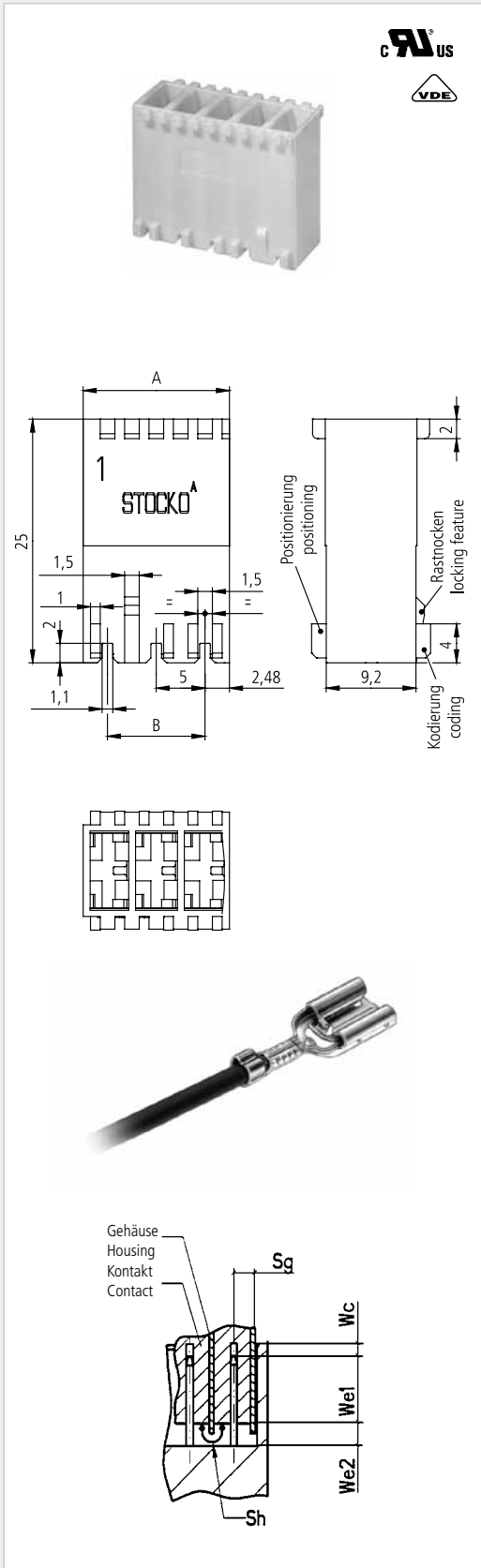

Serie EH 688.400 mit Rastnocken für RAST 5 Komponenten und ECO-FLEX M
Series EH 688.400 with locking features for RAST 5 components and ECO-FLEX M

Gehäuse
Housings

Polzahl Positions	Artikel-Nummer Part number	Abmessungen A Dimensions A	Abmessungen B Dimensions B
2	EH 688.400 - 002 - 0 *	10	5
3	EH 688.400 - 003 - 0 *	15	10
4	EH 688.400 - 004 - 0 *	20	15
5	EH 688.400 - 005 - 0 *	25	20
6	EH 688.400 - 006 - 0 *	30	25
7	EH 688.400 - 007 - 0 *	35	30
8	EH 688.400 - 008 - 0 *	40	35

* Bitte fügen Sie hier die Abarten-Nummer gemäß der RAST 5 Codiertabellen auf den Seiten 100 - 102 ein.
Beispiel: EH 688.400 - 002 - 00A 2poliges Federgehäuse mit Codierung 0A nach RAST 5.

* Please enter here the version number as per the RAST 5 polarizing chart. See pages 100 - 102.
Example: EH 688.400 - 002 - 00A 2-way housing with polarizing 0A to RAST 5.

Kontakte
Contacts

Artikel-Nummer Part number	Leiterquerschnitt Wire size	Material Material	Oberfläche Finishing
RSB 8178.1108 F 6,3 - 1	0,5-1 mm ²	CuZn	verzinkt / tin plated
RSB 8178.1258 F 6,3 - 2,5	>1-2,5 mm ²	CuZn	blank / unplated

Serie EH 699, RAST 5 Crimp

Gehäuse

Series EH 699, RAST 5 Crimp

Housings

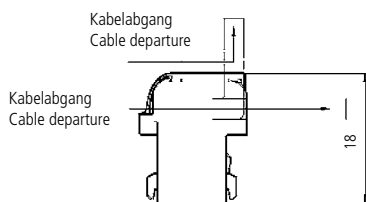
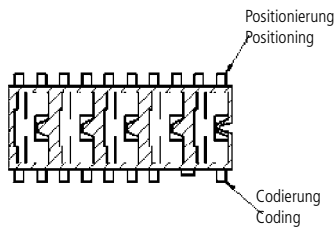
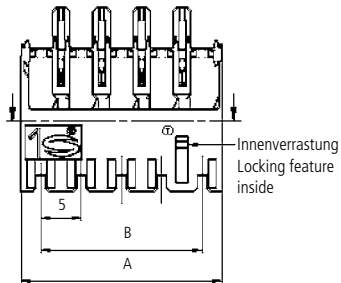
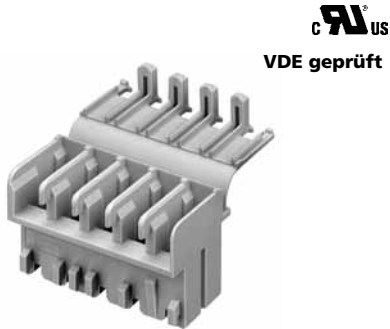

Systembeschreibung

Dieses Gehäuse ist mit der Flachsteckhülse RSB 8240.1158 steckbar auf RAST 5 Stiftwannen und ECO-FLEX M. Das Gehäuse mit Innenverrastung hat unterschiedliche Codierungen und einen wahlweisen Leiterabgang von 90° oder 180°.

Description of system

This housing with receptacle RSB 8240.1158 is designed to interconnect for RAST 5 pin connectors and ECO-FLEX M. The housing with locking feature inside, has various polarizing options and 90° or 180° cable exits.

Gehäuse

Housings

Polzahl Positions	Artikel-Nummer Part number	Abmessungen A Dimensions A	Abmessungen B Dimensions B
2	EH 699 - 002 - 0 *	10	5
3	EH 699 - 003 - 0 *	15	10
4	EH 699 - 004 - 0 *	20	15
5	EH 699 - 005 - 0 *	25	20
6	EH 699 - 006 - 0 *	30	25
7	EH 699 - 007 - 0 *	35	30
8	EH 699 - 008 - 0 *	40	35

* Vorzugstypen siehe Seite 104. Weitere Codierungen auf Anfrage.

* Preferential versions see page 104. More polarizing on request

Derating-Kurve / Derating curve

Leiterquerschnitt: 1,00 mm² / 5-poliger Stecker
Wire size: 1.00 mm² / 5-way connector

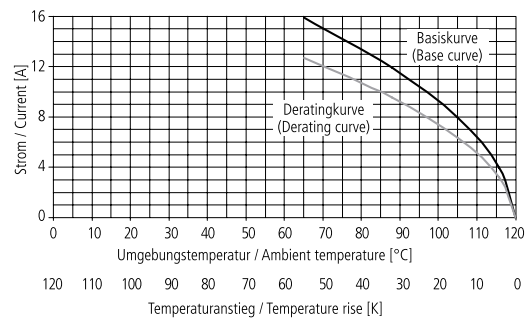

Kontakte

Contacts

Artikel-Nummer Part number	Leiterquerschnitt Wire size	Material Material	Oberfläche Finishing
RSB 8240.1158*	0,5 - 1,5 mm	CuZn	verzinkt / tin plated
RSB 8240.1158*	0,5 - 1,5 mm	Fe	vernickelt / nickel plated

Serie MS 9450, ECO-DOMO PM

Messerleiste für Serien ECO-DOMO, ECO-DOMO FT, EH 688 und EH 699

Series MS 9450, ECO-DOMO PM

Tab connectors for series ECO-DOMO, ECO-DOMO FT, EH 688 and EH 699

Serie MS 9450 Messerleiste nach RAST 5 als fliegende Kupplung oder Schottdurchführung Series MS 9450 Tab connector to RAST 5 for flying lead or panel mounting

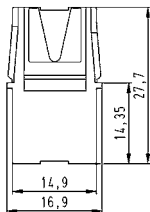
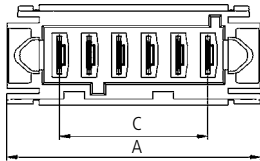
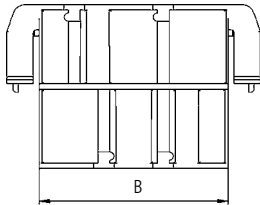

Polzahl Positions	Artikel-Nummer Part number	Abmessungen A Dimensions A	Abmessungen B Dimensions B	Abmessungen C Dimensions C
2	MSVV 9450 - 002 - *	22,8	11,8	5
3	MSVV 9450 - 003 - *	27,8	16,8	10
4	MSVV 9450 - 004 - *	32,8	21,8	15
5	MSVV 9450 - 005 - *	37,8	26,8	20
6	MSVV 9450 - 006 - *	42,8	31,8	25
7	MSVV 9450 - 007 - *	47,8	36,8	30
8	MSVV 9450 - 008 - *	52,8	41,8	35
9	MSVV 9450 - 009 - *	57,8	46,8	40
10	MSVV 9450 - 010 - *	62,8	51,8	45

- * Abarten und Codierungen auf Anfrage.
- * Modifications and polarizings on request.

Steckverbindersystem TL 3 HT

Connector system TL 3 HT

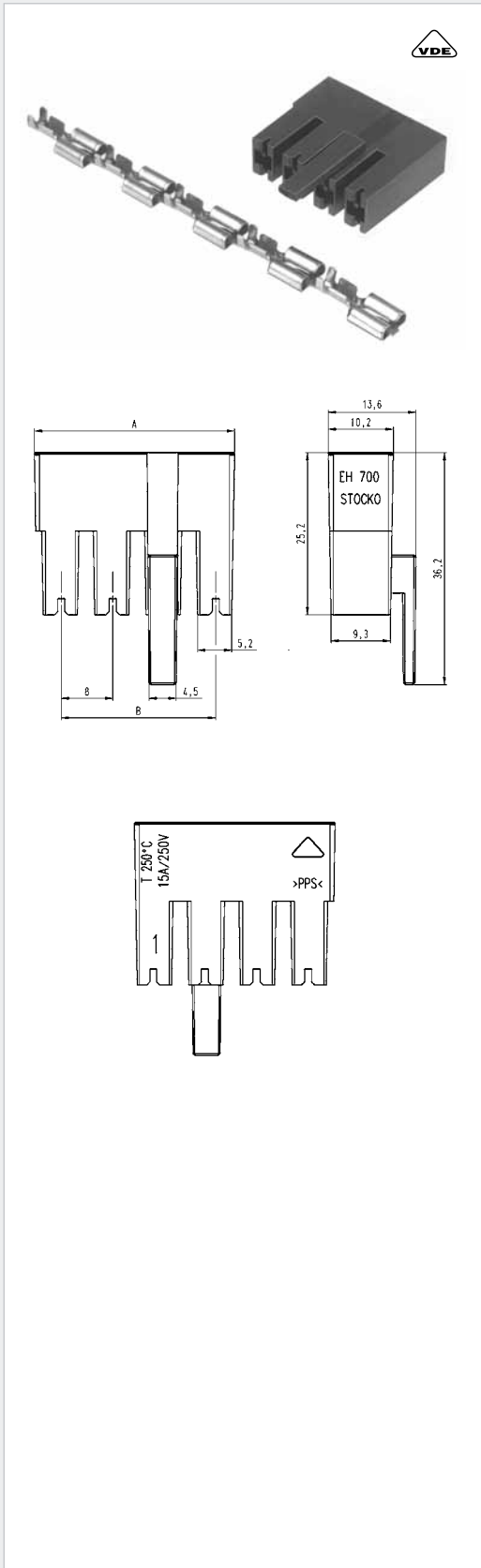

Systembeschreibung

Diese Steckverbinder-Serie, bestehend aus Gehäuse EH 700/4-2 HT und der Flachsteckhülse RSB 8180.1158, ist steckbar auf Flachsteckmesser 6,3 x 0,8 nach DIN 46244. Die Gehäuse haben einen Rasterabstand von 8 mm und sind als Verbindersystem für den Anschluß von Heizplatten geeignet. Temperaturbereich 270°C max.

Description of system

This connector range, which consists of housings EH 700/4-2 HT and receptacle RSB 8180.1158, is designed to interconnect with tabs 6.3 x 0.8 to DIN spec. 46244. The housings have a connector spacing of 8 mm and are ideally suitable to mate with interconnections of electric kitchen hobs. Temperature range 270°C max.

Kontakte

Contacts

Artikel-Nummer Part number	Leiterquerschnitt Wire size	Material Material	Oberfläche Finishing
RSB 8180.1158	0,50-1,50 mm ²	Fe	vernickelt / nickel plated
RSB 8220.1158	0,50-1,50 mm ²	Fe	vernickelt / nickel plated

Gehäuse aus hochtemperaturbeständigem Kunststoff

Housings in high temperature resistant plastic material

Polzahl Positions	Artikel-Nummer Part number	Abmessungen A Dimensions A	Abmessungen B Dimensions B
1	EH 700/1-1 HT	7	
2	EH 700/2-2 HT	15	8
3	EH 700/3-2 HT	23	16
4	EH 700/4-2 HT	31	24

Material: PPS, glühdrahtbeständig, GWT 750°C nach IEC 60335-1

Material: PPS, glow wire resistant, GWT 750°C acc. to IEC 60335-1

Steckverbindersystem TL 4

Connector system TL 4

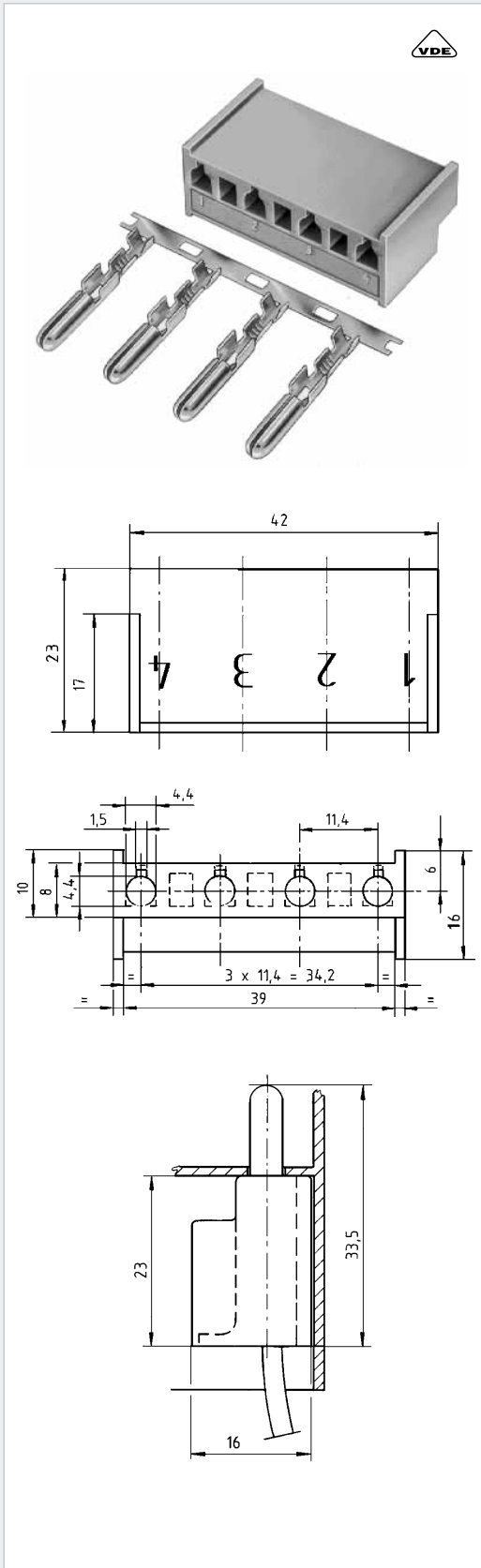

Systembeschreibung

Das Steckverbindersystem TL 4, Raster 11,4 mm, wurde entwickelt, um den Herstellern von Elektroherden die schnelle und sichere Kontaktierung der Kochplatten und Drehschalter in Einbaugeräten zu ermöglichen. Besonderer Wert wurde auf die völlige Automatisierung der Kabelzweigerstellung gelegt. Dadurch wird es möglich, einen hohen Qualitätsstandard zu sichern und erhebliche Kosten einzusparen.

Description of system

The connector system TL 4, pitch 11.4 mm, was developed to provide the manufacturers of electric cookers with a fast and secure means of connecting the cooking rings and rotary switches of built-in appliances. Special attention was paid to the fully automated production of the cable harness. That ensures a high standard of quality coupled with maximum cost efficiency.

Kontakt

Contact

Artikel-Nummer Part number	Leiterquerschnitt Wire size	Material Material	Oberfläche Finishing
RTB 8037 R 4-1	0,38-1mm ²	CuNi 18 Zn 20	blank / unplated
RTB 8037.001 R 4-1,5	0,5-1,5 mm ²	CuNi 18 Zn 20	blank / unplated

Gehäuse

Housings

Polzahl Positions	Artikel-Nummer Part number	Material Material	Farben Colours
4	MKH 044 - 1 - 00A - 400	PBT / UL 94 V 0 max. 150°C	natur / natural
4	MKH 044 - 1 - 00B - 400		schwarz / black
4	MKH 044 - 1 - 00C - 400		grün / green
4	MKH 044 - 1 - 00D - 400		blau / blue
4	MKH 044 - 1 - 00E - 400		rot / red
4	MKH 044 - 1 - 00F - 400		braun / brown

Vorzugstypen ECO-TRONIC

Gehäuserohlinge der Serie MF 7234

Preferential types ECO-TRONIC

Housing slugs series MF 7234

Draufsicht Messerleiste Top view tab connectors

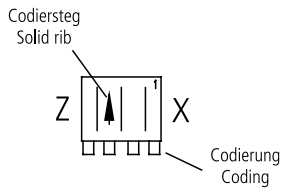

Z = Außenwand / Side wall 0,6 mm
X = Außenwand / Side wall 1,5 mm

Gehäuse mit den dargestellten Codierstegen und Außenwänden sind bevorzugt einzusetzen. Codierungen können frei gewählt werden.

Housings with shown solid ribs and side walls should be used preferably. Codings can be chosen freely.

2polig / 2-way



3polig / 3-way

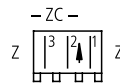

4polig / 4-way



5polig / 5-way

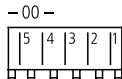

6polig / 6-way

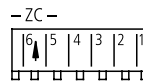
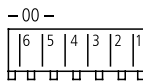

7polig / 7-way

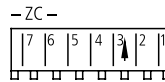
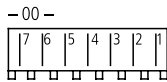

8polig / 8-way

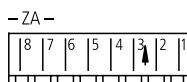

9polig / 9-way

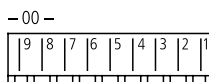

10polig / 10-way

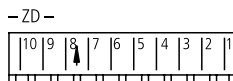

Vorzugstypen ECO-TRONIC

Gehäuserohlinge der Serie MF 7234

Preferential types ECO-TRONIC

Housing slugs series MF 7234

Draufsicht Messerleiste Top view tab connectors

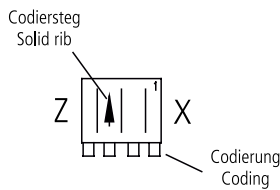

Z = Außenwand / Side wall 0,6 mm
X = Außenwand / Side wall 1,5 mm

Gehäuse mit den dargestellten Codierstegen und Außenwänden sind bevorzugt einzusetzen. Codierungen können frei gewählt werden.

Housings with shown solid ribs and side walls should be used preferably. Codings can be chosen freely.

11polig / 11-way

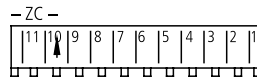

12polig / 12-way

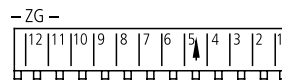

13polig / 13-way

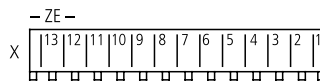

14polig / 14-way

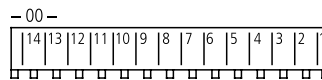

15polig / 15-way

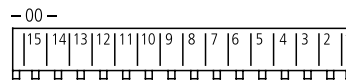

16polig / 16-way

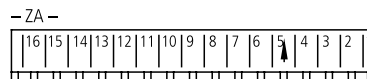

17polig / 17-way

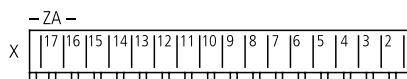

18polig / 18-way

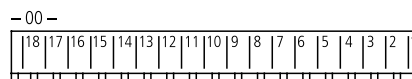

19polig / 19-way

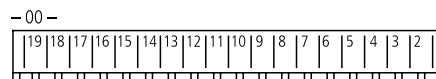

20polig / 20-way

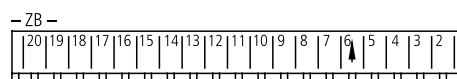

Vorzugstypen ECO-TRONIC

Gehäuserohlinge der Serie MF 7238

Preferential types ECO-TRONIC

Housing slugs series MF 7238

Draufsicht Messerleiste Top view tab connectors

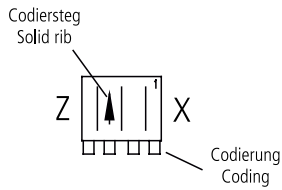

Z = Außenwand / Side wall 0,6 mm
X = Außenwand / Side wall 1,5 mm

Gehäuse mit den dargestellten Codierstegen und Außenwänden sind bevorzugt einzusetzen. Codierungen können frei gewählt werden.

Housings with shown solid ribs and side walls should be used preferably. Codings can be chosen freely.

2polig / 2-way

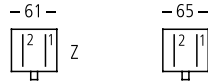

3polig / 3-way

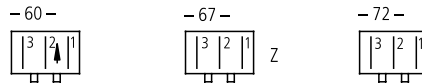

4polig / 4-way



5polig / 5-way

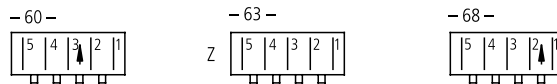

6polig / 6-way

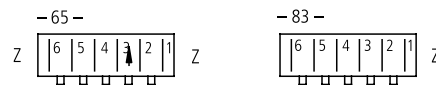

7polig / 7-way

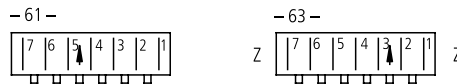

8polig / 8-way

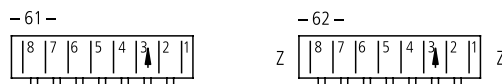

9polig / 9-way



10polig / 10-way

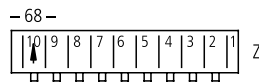
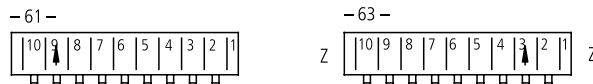

Vorzugstypen ECO-TRONIC

Gehäuserohlinge der Serie MF 7238

Preferential types ECO-TRONIC

Housing slugs series MF 7238

Draufsicht Messerleiste Top view tab connectors

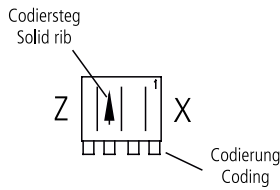

Z = Außenwand / Side wall 0,6 mm
X = Außenwand / Side wall 1,5 mm

Gehäuse mit den dargestellten Codierstegen und Außenwänden sind bevorzugt einzusetzen. Codierungen können frei gewählt werden.

Housings with shown solid ribs and side walls should be used preferably. Codings can be chosen freely.

11polig / 11-way

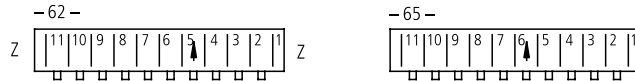

12polig / 12-way

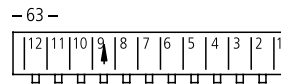

13polig / 13-way

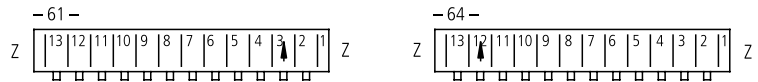

14polig / 14-way

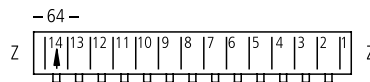

15polig / 15-way

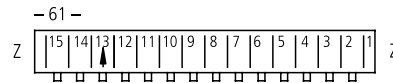

16polig / 16-way

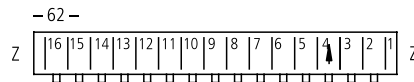

17polig / 17-way

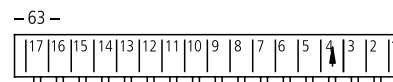

18polig / 18-way

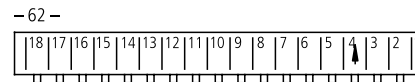

19polig / 19-way

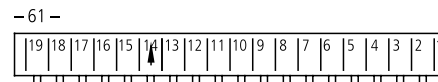

20polig / 20-way

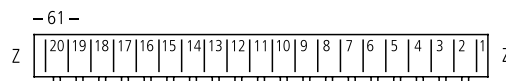

Vorzugstypen ECO-TRONIC

Gehäuserohlinge der Serie MF 7242

Preferential types ECO-TRONIC

Housing slug series MF 7242

Draufsicht Messerleiste Top view tab connectors

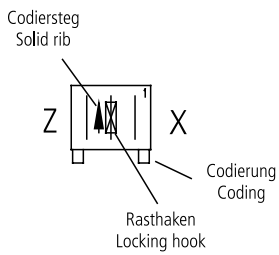

Z = Außenwand / Side wall 0,6 mm
X = Außenwand / Side wall 1,5 mm

Gehäuse mit den dargestellten Codierstegen, Außenwänden und Rasthaken sind bevorzugt einzusetzen. Codierungen können frei gewählt werden.

Housings with shown solid ribs, side walls and locking hooks should be used preferably. Codings can be chosen freely.

3polig / 3-way

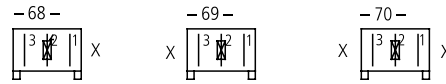

4polig / 4-way

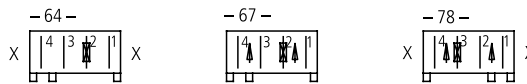

5polig / 5-way



6polig / 6-way

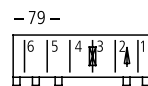

7polig / 7-way

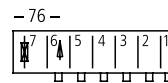

8polig / 8-way

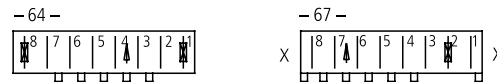

9polig / 9-way

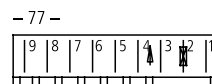

Vorzugstypen ECO-TRONIC

Gehäuserohlinge der Serie MF 7242

Preferential types ECO-TRONIC

Housing slug series MF 7242

Draufsicht Messerleiste Top view tab connectors

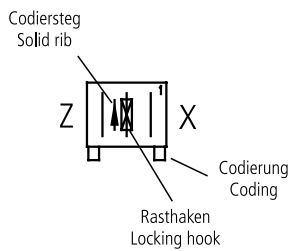

Z = Außenwand / Side wall 0,6 mm
X = Außenwand / Side wall 1,5 mm

Gehäuse mit den dargestellten Codierstegen, Außenwänden und Rasthaken sind bevorzugt einzusetzen. Codierungen können frei gewählt werden.

Housings with shown solid ribs, side walls and locking hooks should be used preferably. Codings can be chosen freely.

10polig / 10-way

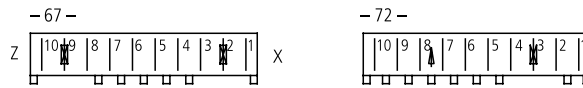

11polig / 11-way

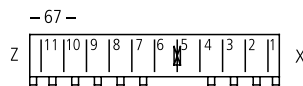

12polig / 14-way

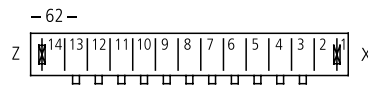

15polig / 15-way

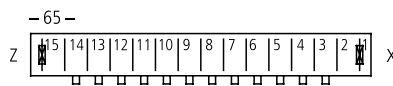

17polig / 17-way

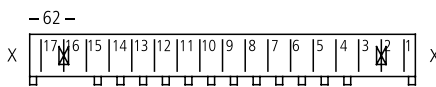

20polig / 20-way



Vorzugstypen ECO-TRONIC pro

Gehäuserohlinge der Serie MF 7260

Preferential types ECO-TRONIC pro

Housing slug series MF 7260

Draufsicht Messerleiste Top view tab connectors

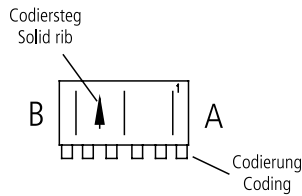

B = Außenwand / Side wall
A = Außenwand / Side wall

Gehäuse mit den dargestellten Codierstegen und Außenwänden sind bevorzugt einzusetzen. Codierungen können frei gewählt werden.

Housings with shown solid ribs and side walls should be used preferably. Codings can be chosen freely.

2polig / 2-way

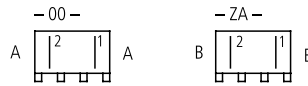

3polig / 3-way

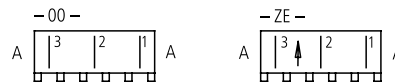

4polig / 4-way

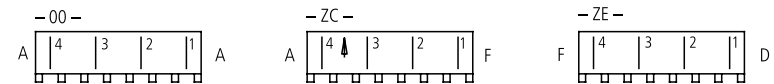

5polig / 5-way

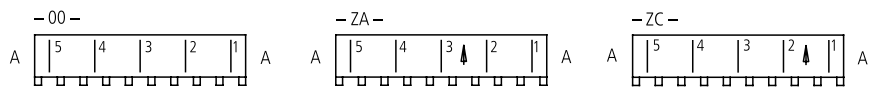

6polig / 6-way

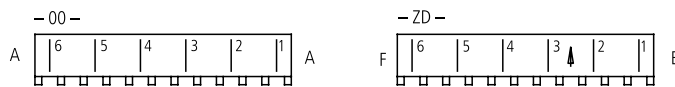

7polig / 7-way

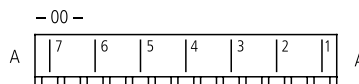

8polig / 8-way

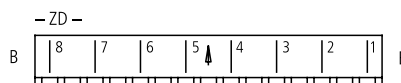

9polig / 9-way



10polig / 10-way

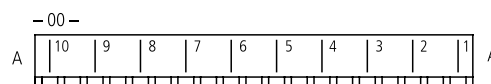

Vorzugstypen ECO-TRONIC pro

Gehäuserohlinge der Serie MF 7262

Preferential types ECO-TRONIC pro

Housing slug series MF 7262

Draufsicht Messerleiste Top view tab connectors

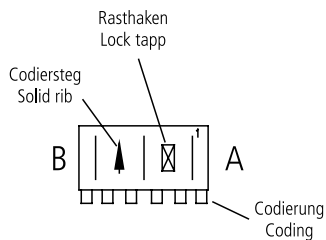

B = Außenwand / Side wall
A = Außenwand / Side wall

Gehäuse mit den dargestellten Codierstegen, Außenwänden und Rasthaken sind bevorzugt einzusetzen. Codierungen können frei gewählt werden.

Housings with shown solid ribs, side walls and locking hooks should be used preferably. Codings can be chosen freely.

2polig / 2-way

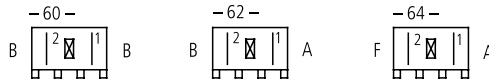

3polig / 3-way

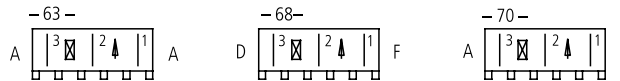

4polig / 4-way

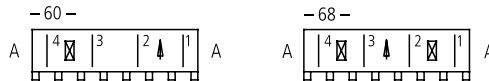

5polig / 5-way

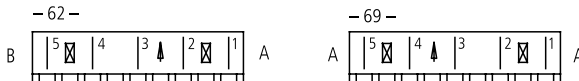

6polig / 6-way

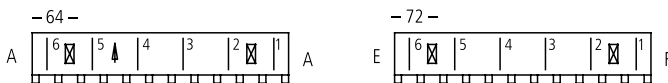

7polig / 7-way

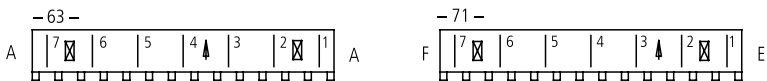

8polig / 8-way

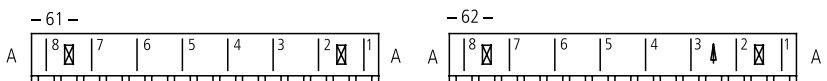

9polig / 9-way

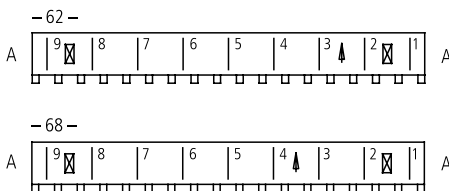

10polig / 10-way

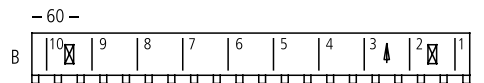

Codierungen ECO-DOMO RAST 5

Polarizing ECO-DOMO RAST 5

Draufsicht Messerleiste Top view tab connectors



Positionierung
Positioning

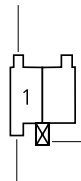

Verrastung
Locking feature

Codierung
Polarizing

2polig / 2-way

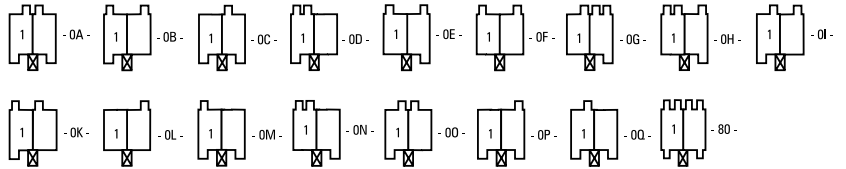

3polig / 3-way

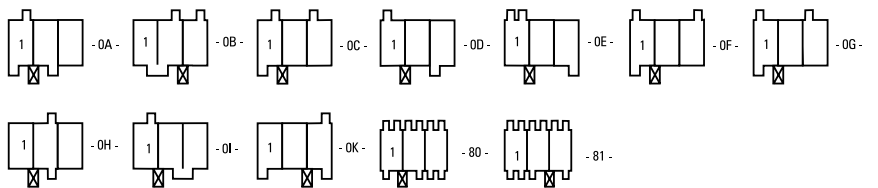

4polig / 4-way

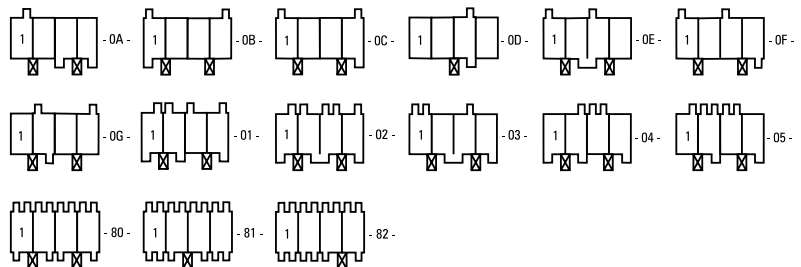

5polig / 5-way

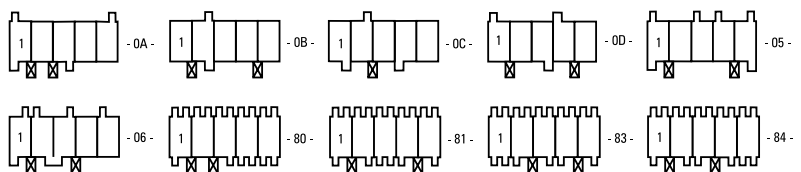

Codierungen ECO-DOMO RAST 5

Polarizing ECO-DOMO RAST 5

Draufsicht Messerleiste Top view tab connectors



Positionierung
Positioning



Codierung
Polarizing

Verrastung
Locking feature



6polig / 6-way

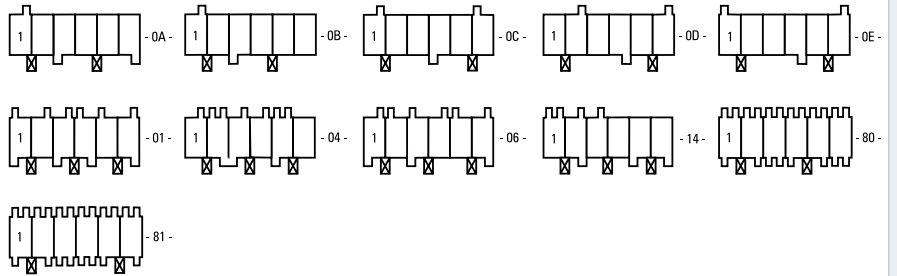

7polig / 7-way

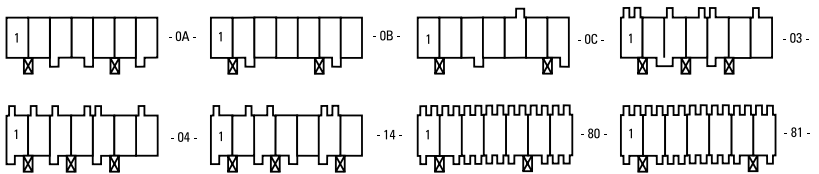

8polig / 8-way

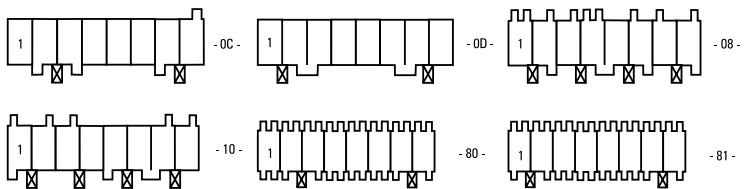

Codierungen ECO-DOMO RAST 5

Polarizing ECO-DOMO RAST 5

Draufsicht Messerleiste Top view tab connectors



Positionierung
Positioning

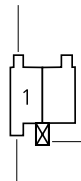

Verrastung
Locking feature

Codierung
Polarizing

9polig / 9-way

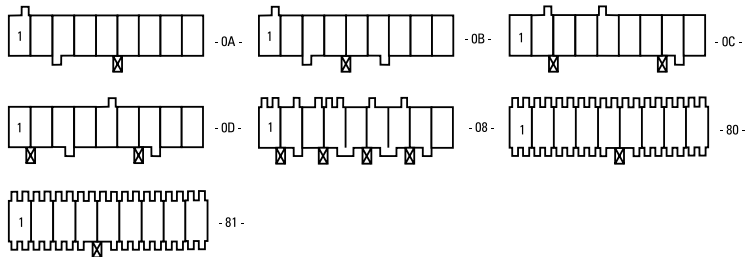

10polig / 10-way

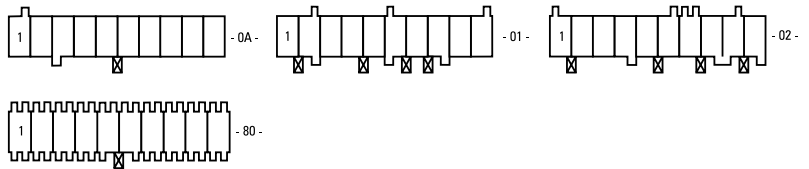

11polig / 11-way

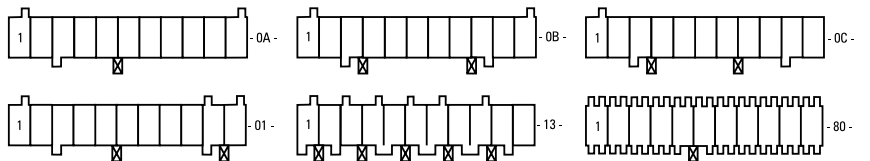

Vorzugstypen ECO-DOMO

Gehäuserohlinge der Serien MF 9586 / MF 9561

Preferential types ECO-DOMO

Housing slug series MF 9586 / MF 9561

Draufsicht Messerleiste Top view tab connectors

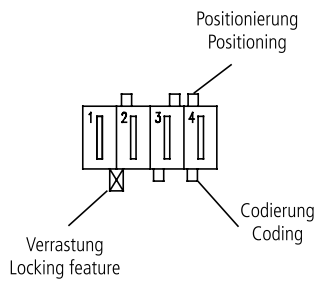

Gehäuse mit den dargestellten Verrastungen sind bevorzugt einzusetzen.

Positionierungen und Codierungen können frei gewählt werden.

Housings with shown locking feature should be used preferably.

Positioning and codings can be chosen freely.

MF 9586 2polig / 2-way

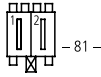

MF 9586 3polig / 3-way

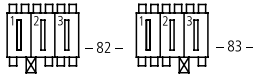

MF 9561 4polig / 4-way

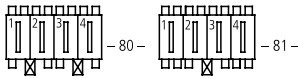

MF 9561 5polig / 5-way

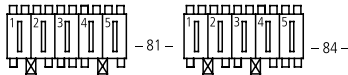

MF 9561 6polig / 6-way

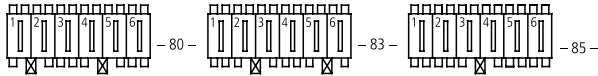

MF 9561 7polig / 7-way

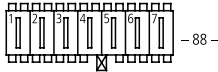

MF 9561 8polig / 8-way

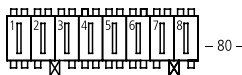

MF 9561 9polig / 9-way

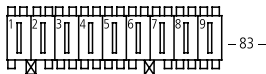

MF 9561 10polig / 10-way

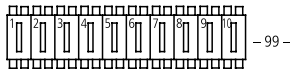

MF 9561 11polig / 11-way

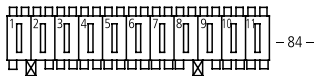

Vorzugstypen EH 688 / EH 699

Preferential types EH 688 / EH 699

Draufsicht Messerleiste Top view tab connectors

Positionierung
Positioning

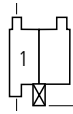

Verrastung
Locking feature

Codierung
Polarizing

EH 688

EH 688-001-004



-04-

EH 688-002-0xx

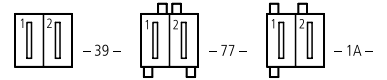

-39-

-77-

-1A-

EH 688-003-0xx

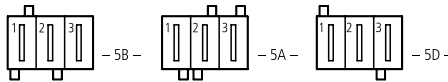

-5B-

-5A-

-5D-

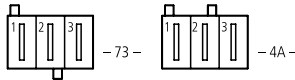

-73-

-4A-

EH 688-004-0xx

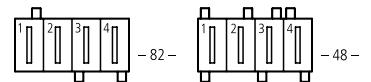

-82-

-48-

EH 688-005-076

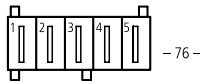

-76-

EH 688-006-01L

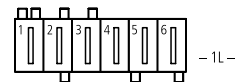

-1L-

EH 688-008-0xx

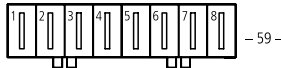

-59-

EH 699

EH 699-002-0xx

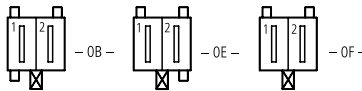

-0B-

-0E-

-0F-

EH 699-003-0xx

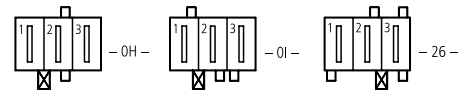

-0H-

-0I-

-26-

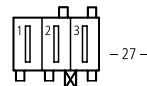

-27-

EH 699-004-0xx

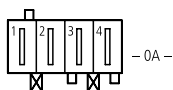

-0A-

EH 699-005-0xx

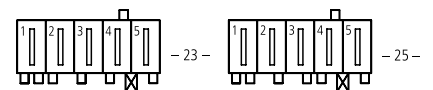

-23-

-25-

Verpackungseinheiten

ECO-TRONIC

Standard packing

ECO-TRONIC

Verpackungseinheiten für Paketmagazine der Serie ECO-TRONIC

Quantities in stick magazines for series ECO-TRONIC



Polzahl Positions	Serie MFMP					Normpackung/ Stück Standardpacking/ pieces
	7234	7236	7237	7238	7242	
3	7234	7236	7237	7238	7242	7008
4	7234	7236	7237	7238	7242	5568
5	7234	7236	7237	7238	7242	4704
6	7234	7236	7237	7238	7242	4032
7	7234	7236	7237	7238	7242	3456
8	7234	7236	7237	7238	7242	3072
9	7234	7236	7237	7238	7242	2784
10	7234	7236	7237	7238	7242	2496
11	7234	7236	7237	7238	7242	2304
12	7234	7236	7237	7238	7242	2112
13	7234	7236	7237	7238	7242	2016
14	7234	7236	7237	7238	7242	1824
15	7234	7236	7237	7238	7242	1728
16	7234	7236	7237	7238	7242	1632
17	7234	7236	7237	7238	7242	1536
18	7234	7236	7237	7238	7242	1440
19	7234	7236	7237	7238	7242	1344
20	7234	7236	7237	7238	7242	1344

Verpackungseinheiten

ECO-TRONIC pro

Standard packing

ECO-TRONIC pro

Verpackungseinheiten für Paketmagazine der Serie ECO-TRONIC pro Quantities in stick magazines for series ECO-TRONIC pro



Polzahl Positions	Serie MFMP				Normpackung/ Stück Standard packing/ pieces
	Series MFMP				
2	7260	7262			7008
3	7260	7262			4704
4	7260	7262			3456
5	7260	7262			2784
6	7260	7262			2304
7	7260	7262			1920
8	7260	7262			1728
9	7260	7262			1536
10	7260	7262			1344

Verpackungseinheiten

ECO-DOMO FT

Standard packing

ECO-DOMO FT

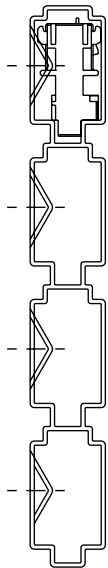

Verpackungseinheiten für Paketmagazine der Serie ECO-DOMO FT Quantities in stick magazines for series ECO-DOMO FT

Polzahl	Serie MFMP				Normpackung/ Stück
Positions	Series MFMP				Standard packing/ pieces
1 - 2 *		9785			2688
1 - 3 *		9785			1624
2	9761				4032
3	9761				2688
4	9761				2016
5	9761				1624
6	9761				1344
7	9761				1176
8	9761				1008
9	9761				896
10	9761				784
11	9761				728
12	9761				672

* Anzahl Gehäuse am Riegel

* Number of housing in chain

Verpackungseinheiten

MTL 1

Standard packing

MTL 1

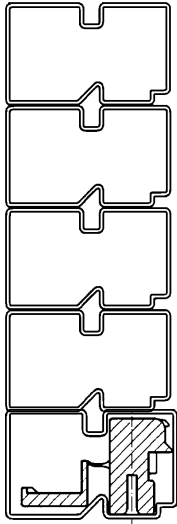

Verpackungseinheiten für Paketmagazine der Serie MTL 1 Quantities in stick magazines for series MTL 1

Polzahl Positions	Serie MTL 1 FMP				Normpackung/ Stück Standard packing/ pieces
	Series MTL 1 FMP				
2	6692	6672	6712		3600
3	6693	6673	6713		2400
4	6694	6674	6714		1800
5	6695	6675	6715		1450
6	6696	6676	6716		1200
7	6697	6677	6717		1050
8	6698	6678	6718		900
9	6699	6679	6719		800
10	6700	6680	6720		700
11	6701	6681	6721		650
12	6702	6682	6722		600

Verpackungseinheiten

ECO-DOMO

Standard packing

ECO-DOMO

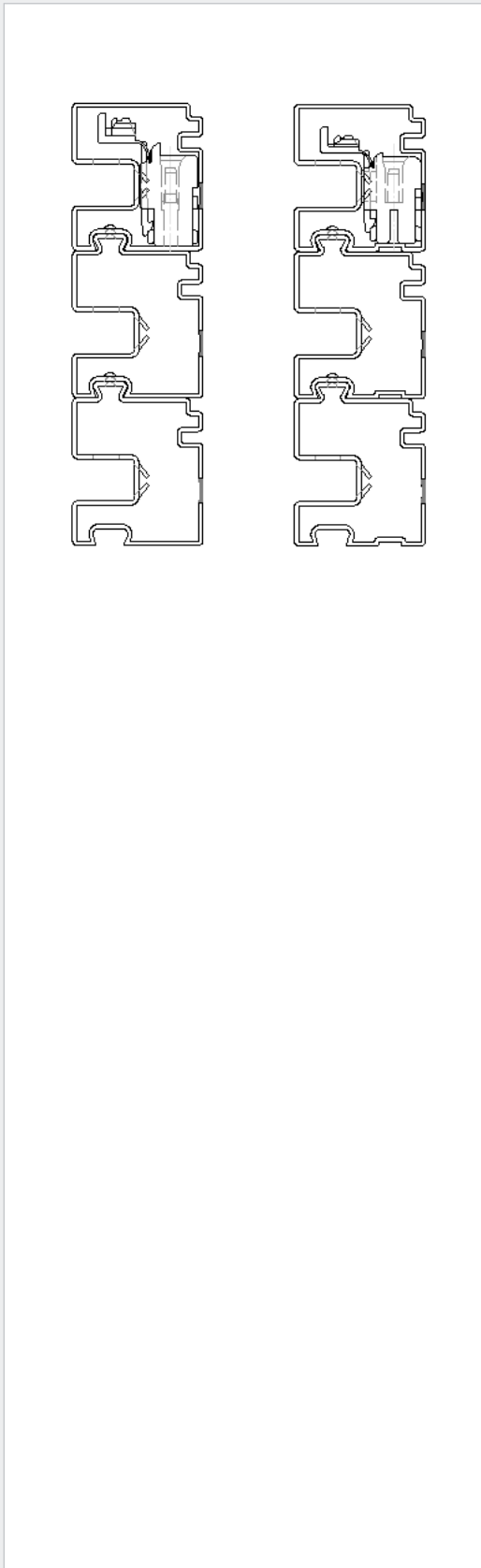

Verpackungseinheiten für Paketmagazine der Serie ECO-DOMO Quantities in stick magazines for series ECO-DOMO

Polzahl Positions	Serie MFMP					Normpackung/ Stück Standard packing/ pieces
	Series MFMP					
1 - 2	-	9285	-	-	-	2880
1 - 3	-	9285	-	-	-	2610
2	9260	9261	9270	9271	9290	2160
3	9260	9261	9270	9271	9290	1440
4	9260	9261	9270	9271	9290	1080
5	9260	9261	9270	9271	9290	870
6	9260	9261	9270	9271	9290	720
7	9260	9261	9270	9271	9290	600
8	9260	9261	9270	9271	9290	540
9	9260	9261	9270	9271	9290	480
10	9260	9261	9270	9271	9290	420
11	9260	9261	9270	9271	9290	390
12	9260	9261	9270	9271	9290	360

Service Handzangen

Service hand tools



Service-Handzange WZ TL 1

Ansetzzange für die Verarbeitung des Steckverbindersystems TL 1 mit Schneidklemmanschluß, Raster 5 mm.

Angesetzt werden ausschließlich Einzelleiter.

Service hand tool WZ TL 1

Terminating tool for the TL 1 connector system in insulation displacement version, pitch 5 mm.

Only for terminating discrete wires.



Service-Handzange WZ-ED

Ansetzzange für die Verarbeitung der Steckverbindersysteme ECO-DOMO mit Schneidklemmanschluß, Raster 5 mm.

Angesetzt werden ausschließlich Einzelleiter.

Service hand tool WZ-ED

Terminating tool for the ECO-DOMO connector systems in insulation displacement version, pitch 5 mm.

Only for terminating discrete wires.



Service-Handzange WZ/P-ED FT

Ansetzzange für die Verarbeitung des Steckverbindersystems ECO-DOMO FT mit Schneidklemmanschluß, Raster 5 mm.

Angesetzt werden ausschließlich Einzelleiter.

Service hand tool WZ/P-ED FT

Terminating tool for the ECO-DOMO FT connector system in insulation displacement version, pitch 5 mm.

Only for terminating discrete wires.

Service-Handzange WZ / P-R 2,5 pro

Ansetzzange zur Verarbeitung der Steckverbindersysteme ECO-TRONIC / ECO-TRONIC pro mit Schneidklemmanschluß.

Angesetzt werden ausschließlich Einzelleiter.

Service hand tool WZ / P-R 2,5 pro

Terminating tool for connector systems ECO-TRONIC / ECO-TRONIC pro, in insulation displacement versions.

Only for terminating discrete wires.



Service-Handzange WZ 111 R 2,5 S

Ansetzzange zur Verarbeitung der ECO-TRONIC Schotttdurchführung mit Schneidklemmanschluß, Raster 2,5 mm.

Angesetzt werden ausschließlich Einzelleiter.

Service hand tool WZ 111 R 2.5 S

Terminating tool for the ECO-TRONIC pin connector panel mount, IDC portion, pitch 2.5 mm.

Only for terminating discrete wires.

Werkzeuge

Tools



WZ 63
Handgriff für Werkzeugköpfe.
Hand grip for tool heads.



WT 3
Handhebelpresse für Werkzeugköpfe
Hand lever press for tool heads

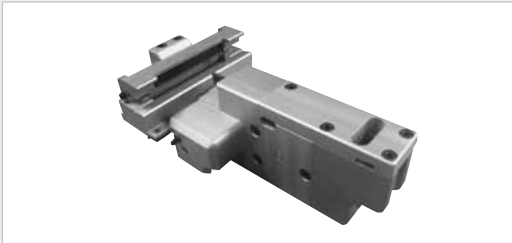

Werkzeugkopf WK / P-TL 1
Werkzeugkopf für die Verarbeitung des Steckverbindersystems TL 1 mit Schneidklemmanschluß, Raster 5 mm.
Angesetzt werden ausschließlich Einzelleiter.

Tool head WK / P-TL 1
Tool head for connector system TL 1 insulation displacement version, pitch 5 mm.
Only for terminating discrete wires.



Werkzeugkopf WK / P-ET B
Werkzeugkopf WK / P-R 2,5
Werkzeugkopf WK / P-R 2,5 pro
Werkzeugkopf WK / P-R 2,5 S
Werkzeugkopf WK / P-ED FT
Werkzeugkopf WK / P-ED TI
Werkzeugkopf WK / P-ED 030 pre-line

Werkzeugköpfe für die Verarbeitung der Steckverbindersysteme ECO-TRONIC (Raster 2,5 und 5 mm), ECO-DOMO, ECO-DOMO FT und ECO-DOMO TI.
Die Kontaktierung der Einzelleiter und der Vorschub der Stecker in die nächste Ansetzposition erfolgt in einem Arbeitsgang.

Tool head WK / P-ET B
Tool head WK / P-R 2,5
Tool head WK / P-R 2,5 pro
Tool head WK / P-R 2,5 S
Tool head WK / P-ED FT
Tool head WK / P-ED TI
Tool head WK / P-ED 030 pre-line

Tool heads for connector systems ECO-TRONIC (2.5 and 5 mm pitch), ECO-DOMO, ECO-DOMO FT and ECO-DOMO TI.
Terminating the discrete wires and bringing the connector into the next contacting position is done in one operational cycle.

Alle Werkzeugköpfe können auch auf dem STOCKOMAT IDC *pre-line* eingesetzt werden (s. Seite 98).
All tool heads are also suitable for STOCKOMAT IDC *pre-line* (see page 98).

STOCKOMAT IDC *pre-line*

WT 3100-1

Elektrischer Antrieb zur Verarbeitung der Steckverbindersysteme ECO-TRONIC, ECO-TRONIC pro, ECO-DOMO, ECO-DOMO FT, ECO-DOMO TI und TL 1. Es stehen die Werkzeugköpfe von Seite 97 zur Verfügung.

Electrical drive assembly to terminate the connector systems ECO-TRONIC, ECO-TRONIC pro, ECO-DOMO, ECO-DOMO FT, ECO-DOMO TI and TL 1. For terminating are the tool heads from page 97 available.



Merkmale

- Taktzeit 1 Sek.
- Schneller Wechsel produktspezifischer Werkzeugköpfe
- Tischgerät in ergonomischer Form
- Zählwerk
- Spannungswechsler 110/220 V
- Bedienung durch Sicherheitsfußschalter
- Geringer Energieverbrauch
- Zertifikation nach CE und EMV

Main Features

- Working cycle 1 Sec.
- Quick change of product related tool heads
- Bench machine of ergonomic design
- Parts counter
- Voltage switch 110/220 V
- Operation by foot switch
- Low energy consumption
- Certification to CE and EMV

STOCKOMAT ECO-TRONIC / ECO-DOMO FT *economy line*

WT 365

Halbautomat für die Verarbeitung der Steckverbindersysteme ECO-DOMO FT, ECO-TRONIC, ECO-TRONIC pro.
Semi-automated machine for terminating connector systems ECO-DOMO FT, ECO-TRONIC, ECO-TRONIC pro.



Merkmale

- Tischgerät
- Wirtschaftliche Paketmagazine
- Verarbeitung Steckverbinder
 - 1-12 pol. ECO-DOMO FT
 - 2-10 pol. ECO-TRONIC pro
 - 2-20 pol. ECO-TRONIC
- Keine Trennung der Gehäuse am Riegel
- Einzelkontaktierung
- Leerkammerprogrammierung
- Kontaktierung über Niederdruckstaudüse
- Prüfung der Leitungseinlegetiefe
- Max. Ladenutzen
 - 24 Raster, ECO-DOMO FT, ECO-TRONIC pro
 - 42 Raster, ECO-TRONIC
 - je nach Gehäuseabmessung

Features

- Bench mounted
- Economical product magazines
- Terminating connector versions
 - 1-12 pole ECO-DOMO FT
 - 2-10 pole ECO-TRONIC pro
 - 2-20 pole ECO-TRONIC
- No separation of housings in chain
- Single wire termination
- Programmable for unloaded cavities
- Operated by means of low impact-pressure tube
- Positions check of the wire
- Max. load utilization
 - 24 contact spacings, ECO-DOMO FT, ECO-TRONIC pro
 - 42 contact spacings, ECO-TRONIC
 - relative to housing sizes

Technische Daten

- | | |
|----------------------------|---------------|
| ■ Antrieb | pneumatisch |
| ■ Betriebsspannung | 230 V / 50 Hz |
| ■ Steuerspannung | 24 V DC |
| ■ Anschlußwert | 0,9 kW |
| ■ Betriebsdruck | 6,5 bar |
| ■ Lärmentwicklung | <60 dB (A) |
| ■ Abmessungen | |
| Breite | 475 mm |
| Länge | 914 mm |
| Höhe (o. Magazin) | 600 mm |
| ■ Gewicht | 85 kg |
| ■ Zykluszeit im Einzeltakt | 1,2 Sek. |
| ■ Zertifikation | CE |

Technical Data

- | | |
|----------------------------------|---------------|
| ■ Drive | pneumatic |
| ■ Operating voltage | 230 V / 50 Hz |
| ■ Control voltage | 24 V DC |
| ■ Connected load | 0.9 kW |
| ■ Operating pressure | 6.5 bar |
| ■ Noise level | <60 dB (A) |
| ■ Dimensions | |
| Width | 475 mm |
| Length | 914 mm |
| Height (without magazine) | 600 mm |
| ■ Weight | 85 kg |
| ■ Cycle time, single termination | 1.2 sec. |
| ■ Certification | CE |

Zusätzliche Optionen auf Anfrage
More optional features on request

STOCKOMAT ECO-DOMO *economy line*



WT 255

Halbautomat für die Verarbeitung des Steckverbindersystems ECO-DOMO.
Semi-automated machine for terminating connector system ECO-DOMO.

Merkmale

- Tischgerät
- Wirtschaftliche Paketmagazine
- Verarbeitung von 2-12-poligen Steckverbindern
- Einzelkontaktierung
- Manuelle Deckelschließstation
- Leerkammerprogrammierung
- Sensorauslösung
- Fertigungsüberwachung durch integrierte IDC-Prüfstation
- Abtrennen fehlerhafter Leitungen

Technische Daten

- | | |
|----------------------------|---------------|
| ▪ Antrieb | pneumatisch |
| ▪ Betriebsspannung | 230 V / 50 Hz |
| ▪ Stromaufnahme | 4 A |
| ▪ Anschlußwert | 0,9 kW |
| ▪ Betriebsdruck | 6,5 bar |
| ▪ Abmessungen | |
| Länge | 914 mm |
| Breite | 469 mm |
| Höhe (ohne Magazin) | 573 mm |
| ▪ Gewicht | 81 kg |
| ▪ Zykluszeit im Einzeltakt | 1,2 Sek. |
| ▪ Zertifizierung | CE |

Features

- Bench mounted
- Economical product magazines
- Terminating 2 - 12 ways connector versions
- Single wire termination
- Hand-operated closing station for lid
- Programmable for unloaded cavities
- Sensor switch
- Production control by integrated IDC-testing station
- Separating of incorrect wire

Technical Data

- | | |
|----------------------------------|---------------|
| ▪ Drive | pneumatic |
| ▪ Operating voltage | 230 V / 50 Hz |
| ▪ Current load | 4 A |
| ▪ Connected load | 0.9 kW |
| ▪ Pneumatics | 6.5 bar |
| ▪ Dimensions | |
| Length | 914 mm |
| Width | 469 mm |
| Height (without magazine) | 573 mm |
| ▪ Weight | 81 kg |
| ▪ Cycle time, single termination | 1.2 sec. |
| ▪ Certification | CE |

STOCKOMAT ECO-TRONIC *professional line*

STOCKOMAT ECO-TRONIC *premium line*



WT 165

Halbautomat zum Kontaktieren von ECO-TRONIC Federgehäusen in Schneidklemmtechnik.
Semi automated system for the insulation displacement termination of ECO-TRONIC housings.

Merkmale

- Verarbeitung von 2-10-poligen Steckverbindern ECO-TRONIC pro und 2-20-poligen Steckverbindern der Serie ECO-TRONIC
- Wirtschaftliche Paketmagazine
- Einfache, übersichtliche Handhabung
- SPS-Steuerung mit Klartextanzeige
- Automatische Steckerzuführung
- Einzelkontaktierung
- Leerkammerprogrammierung
- Kleine Baugröße
- Geringer Energieverbrauch
- Qualitätssicherung durch integrierte Prüfungen
- Geringe Rüstzeiten bei Polzahlwechsel
- Zertifikation nach CE und EMV

Main Features

- Terminating 2-10 ways connector versions ECO-TRONIC pro and 2-20 ways connector versions ECO-TRONIC
- Economical product magazines
- Easy and clear to operate
- SPS control with plain language display
- Automated connector feed
- Single wire termination
- Empty-chamber programming
- Small, compact machine size
- Low power consumption
- Quality assurance through tests integrated into the programme
- Low setting up times when changing to different connectors
- Certification to CE and EMV

Technische Daten

- | | |
|---------------------|------------------------|
| ▪ Antrieb | pneumatisch |
| ▪ Maschinentaktzeit | 0,5 sec. ohne Handling |
| ▪ Betriebsspannung | 230 V / 50 Hz |
| ▪ Steuerspannung | 240 DC |
| ▪ Anschlußwert | 0,9 kW |
| ▪ Luftdruck | min. 6,5 bar |
| ▪ Luftverbrauch | 1 NL/Zyklus 60 NL/min. |

Technical Data

- | | |
|---------------------|---------------------------|
| ▪ Drive | pneumatic |
| ▪ Cycle time | 0.5 sec. without handling |
| ▪ Operating voltage | 230 V / 50 Hz |
| ▪ Control voltage | 240 DC |
| ▪ Connected load | 0.9 kW |
| ▪ Pneumatics | min. 6.5 bar |
| ▪ Air consumption | 1 NL/Cycle 60 NL/min. |

WT 165.8.1

Beschreibung wie WT 165, jedoch zur Integration an Komax Zeta 633 (siehe Seite 103).
Description as for WT 165, but for integration to Komax Zeta 633 (see page 103).

WT 165.7

Beschreibung wie WT 165, jedoch zur Verarbeitung von ECO-TRONIC mit Rasterstegleitung.
Description as for WT 165, but for terminating the ECO-TRONIC connectors with ribbon cable.

WT 165.9.0 ECO-TRONIC *premium line*

Standardmaschine wie WT 165, jedoch mit Programmbibliothek. Weitere Optionen auf Anfrage
Standard machine as above WT 165, but with program library. More options on request

STOCKOMAT ECO-DOMO *professional line*

STOCKOMAT TL 1 *professional line*



STOCKOMAT ECO-DOMO

WT 155

Halbautomat zum Kontaktieren von ECO-DOMO Federgehäusen in Schneidklemmtechnik.
Semi automated system for the insulation displacement termination of ECO-DOMO housings.

Merkmale

- Wirtschaftliche Paketmagazine
- Einfache, übersichtliche Handhabung
- SPS-Steuerung mit Klartextanzeige
- Automatische Steckerzuführung
- Einzelkontaktierung
- Deckelschließstation
- Leerkammerprogrammierung
- Geringe Rüstzeiten bei Polzahlwechsel
- Fertigungsüberwachung durch integrierte IDC-Prüfstation
- Zertifikation nach CE und EMV
- Abtrennen fehlerhafter Leitungen

Technische Daten

- | | |
|---------------------|---------------------------|
| ▪ Antrieb | pneumatisch |
| ▪ Maschinentaktzeit | 0,85 sec. ohne Handling |
| ▪ Betriebsspannung | 230 V / 50 Hz |
| ▪ Steuerspannung | 240 DC |
| ▪ Anschlußwert | 0,9 kW |
| ▪ Luftdruck | 6,5 bar |
| ▪ Luftverbrauch | 2,5 NL/Zyklus 150 NL/min. |

Main Features

- Economical product magazines
- Easy and clear to operate
- SPS control with plain language display
- Automated connector feed
- Single wire termination
- Cover closing station
- Empty-chamber programming
- Low setting up times when changing to different connectors
- Production control by integrated IDC-testing station
- Certification to CE and EMV
- Separating of incorrect wire

Technical Data

- | | |
|---------------------|----------------------------|
| ▪ Drive | pneumatic |
| ▪ Cycle time | 0.85 sec. without handling |
| ▪ Operating voltage | 230 V / 50 Hz |
| ▪ Control voltage | 240 DC |
| ▪ Connected load | 0.9 kW |
| ▪ Pneumatics | 6.5 bar |
| ▪ Air consumption | 2.5 NL/Cycle 150 NL/min. |

WT 155.7.1

Beschreibung wie WT 155, jedoch zur Integration an Komax Zeta 633 (siehe Seite 103).
Description as for WT 155, but for integration to Komax Zeta 633 (see page 103).

STOCKOMAT TL 1

WT 85.5

Beschreibung wie WT 155, jedoch für die Verarbeitung von TL 1 Federgehäusen.
Die Prüf- und Kabelabwinkelstationen gehören zur Standardausstattung.

Description as for WT 155, but for terminating TL 1 housings.
The testing station and cable bending device are standard features.

Komax ZETA 633

... mit / with STOCKKOMAT ECO-DOMO professional line
oder / or STOCKKOMAT ECO-TRONIC professional line

Anbindung STOCKKOMAT ECO-DOMO bzw. ECO-TRONIC professional line an Crimpvollautomat ZETA 633 für eine vollautomatische einseitige IDC-Bestückung.

Attaching STOCKKOMAT ECO-DOMO or ECO-TRONIC professional line respectively to crimping automaton ZETA 633 for a fully automated single sided IDC termination.



Komax ZETA 633



STOCKKOMAT ECO-DOMO

Merkmale

- Herstellung von Kabelsträngen mit Crimp- und IDC-Kontakten
- Die STOCKKOMAT professional line Automaten sind auch als Einzelmaschine einsetzbar
- Umrüstung an Zeta 633 von WT 155 auf WT 165 möglich

Features

- Production of cable assemblies with crimp and IDC contacts
- The STOCKKOMAT professional line machines can also be used as stand-alone individual machines
- Changes at the Zeta 633 from WT 155 to WT 165 are possible

Zu verarbeitende IDC-Kabel

Leiterquerschnitt:	
ECO-DOMO	0,50 - 1,5 mm ²
ECO-TRONIC	0,22 - 0,35 mm ²
ECO-TRONIC pro	0,50 - 0,75 mm ²

Kabellänge beidseitig angeschlagen:	200-3000 mm, Produktionsleistung: ca. 2000 Leitungen/Stunde
Kabellänge Doppelcrimp:	240-3000 mm, Produktionsleistung: ca. 1000 Leitungen/Stunde

Suitable IDC Cables

Wire size:	
ECO-DOMO	0.50 - 1.5 mm ²
ECO-TRONIC	0.22 - 0.35 mm ²
ECO-TRONIC pro	0.50 - 0.75 mm ²

Cable length if terminated at both ends:	200-3000 mm, Manufacturing cycle: Approx. 2000 assemblies/hour
Cable length with double crimp:	240-3000 mm, Manufacturing cycle: Approx. 1000 assemblies/hour



ECO MASTER

Vollautomat zur Verarbeitung der Steckverbinderserien ECO-TRONIC, ECO-TRONIC pro, ECO-DOMO FT und optional Crimpkontakten.

Fully automated terminating machine for connector series ECO-TRONIC, ECO-TRONIC pro, ECO-DOMO FT and optional crimp contacts.

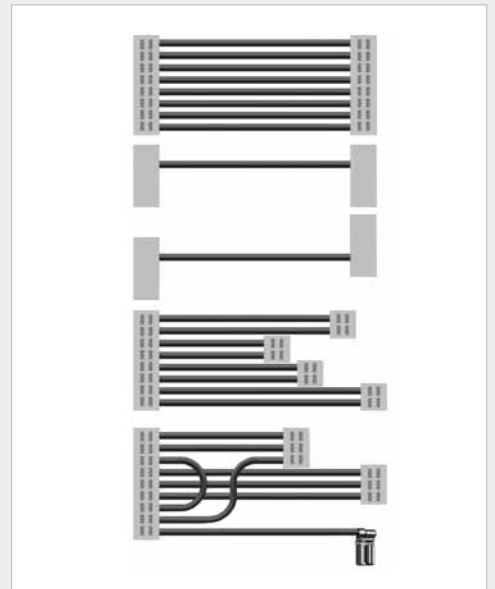
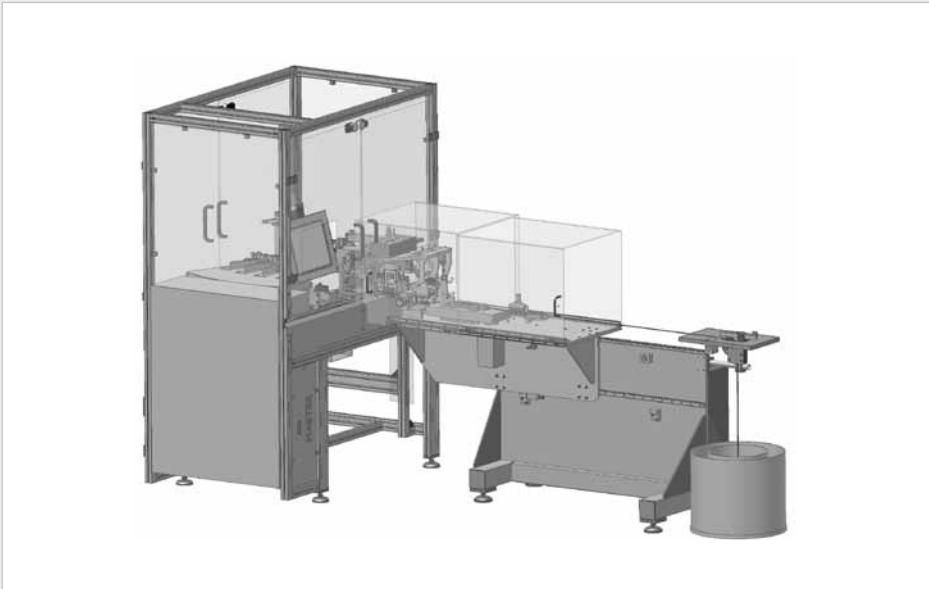

Merkmale

- Vollautomatische Fertigung komplexer Kabelbäume
- Die Steckerserien ECO-TRONIC, ECO-TRONIC pro und ECO-DOMO FT können gleichzeitig verarbeitet werden.
- Optional: Verarbeitung von Crimpkontakten
- Automatische Kabelzuführung, 1-fach
- 8 Steckerzuführstationen für drei Steckverbindersysteme
- Einfache Maschineneinrichtung
- Frei programmierbare Kabelstrangkongfiguration aus bis zu 6 unterschiedlichen Steckern, beliebige Anschlagpositionen der Leitungen innerhalb des Nutzens, unterschiedliche Leitungslängen.
- Optionale Zusatzfunktion: Codierstiftschneiden
- Qualitätssicherung durch integrierte Prüfstationen und Ausschussweiche
- Kabelstrangablage in Entnahmeschiene

Features

- Fully automated production of complex harnesses
- The connector systems ECO-TRONIC, ECO-TRONIC pro and ECO-DOMO FT can be processed simultaneously
- Optional: Processing of crimp contacts
- Automatic wire feeder for one wire
- Eight connector feeding units for three connector systems
- Easy machine setup
- Freely programmable harness configurations composed of up to six different connectors, arbitrary termination position within the loaded lot for each wire end, different wire lengths.
- Optional additional function: cutting of coding pegs
- Quality assurance by integrated testing stations and reject gate
- Storage of produced harnesses in a removal bar

WT 380

Beschreibung wie oben, jedoch als halbautomatische Ansetzmaschine mit manueller Kabelzuführung.

Description as above, but semi-automatic terminating machine with manual wire feeder.

ECO-STAR

Vollautomat für die Verarbeitung der Steckverbinderserien ECO-TRONIC, ECO-TRONIC pro, ECO-DOMO FT.
Fully automated terminating machine for connector series ECO-TRONIC, ECO-TRONIC pro, ECO-DOMO FT.

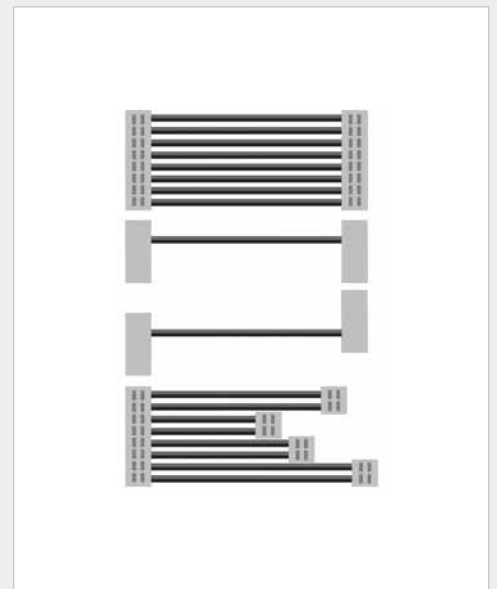

Merkmale

- Hocheffiziente Jumperfertigung
- Einfache Bedienung
- Geringe Rüstzeiten
- Modulares Konzept
- Kompaktes Maschinendesign
- Sehr gutes Preis/Leistungsverhältnis
- Maschinenkonzept für verschiedene Steckverbindersysteme

Kabelzweigmerkmale

- Minimale/maximale Leitungslänge
200 mm/2800 mm
- Leiterquerschnitte
0,22 - 0,35 mm² ECO-TRONIC
0,50 - 0,75 mm² ECO-TRONIC pro
0,35 - 1,00 mm² ECO-DOMO FT
- U-Form-Kabelzweig
- Parallele Leitungen, gleiche Polzahlen auf beiden Seiten des Kabelzweigs
- Z-Form-Kabelzweig
- Parallele Leitungen, gleiche Polzahlen auf beiden Seiten des Kabelzweigs
- Unterschiedliche Polzahlen auf beiden Seiten des Kabelzweigs, gleiche oder bis zu 4 unterschiedliche Längen, bis zu 4 Rasterspreizungen auf Seite der kleineren Stecker

Main Features

- Highly efficient manufacture of jumper lead assemblies
- Simple to operate
- Low setting-up times
- Modular concept
- Compact machine design
- Excellent price/performance relation
- Machine concept suitable for various connector systems

General Cable Assembly Features

- Minimum/maximum conductor lengths
200 mm/2800 mm
- Wire Sizes
0.22 – 0.35 mm² ECO-TRONIC
0.50 – 0.75 mm² ECO-TRONIC pro
0.35 – 1.00 mm² ECO-DOMO FT
- U-shape cable assembly
- Parallel conductors, equal number of ways at both cable ends
- Z-shape cable assembly
- Parallel conductors, equal numbers of ways at both cable ends
- Different numbers of ways at both cable ends, equal or up to 4 different cable lengths, up to 4 pitch spreads at the end with the smaller connector

InTeCon ECO-TRONIC

Vollautomatische IDC-Ansetzmaschinen zur Verarbeitung der Steckverbindersysteme ECO-TRONIC und ECO-TRONIC pro.

Fully automated terminating machines for connector series ECO-TRONIC and ECO-TRONIC pro.

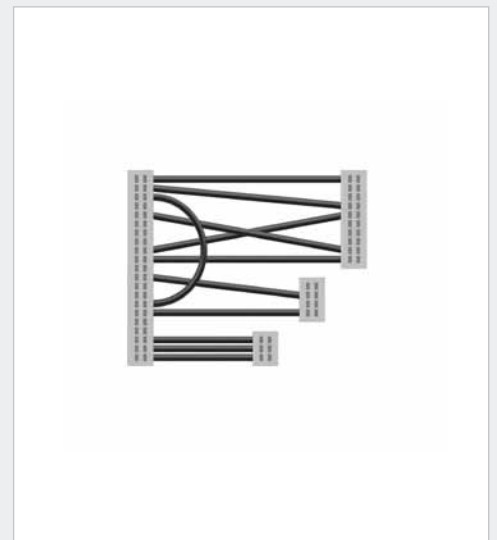

Merkmale

- Alle Versionen des jeweiligen Steckverbindersystems können in einem Fertigungslos verarbeitet werden.
- Gleichzeitige Verarbeitung von bis zu fünf unterschiedlichen Steckern, Polzahlen, Codierungsvarianten usw.
- Verpackung der Stecker in wirtschaftlichen Paketmagazinen
- Manueller Wechsel der Paketmagazine
- Optional: zusätzliche Steckerführeinheit für Magazinwechsel ohne Fertigungsunterbrechung
- Verarbeitung von bis zu sechs unterschiedlichen Leitungen, frei programmierbare Leitungslängen
- Parallele und gekreuzte Leitungen sind ebenso herstellbar wie Schlaufen und nur einseitig angeschlagene Leitungen
- Qualitätssicherung durch integrierte Prüfstationen und Ausschussweiche
- Manuelles Entladen der gefertigten Kabelbäume
- Optional: Automatische Ablage in Stangenmagazinen

Spezielle Merkmale InTeCon ECO-TRONIC

- Maschine zur Verarbeitung von ECO-TRONIC oder ECO-TRONIC pro Steckverbindern
- Einfache Umrüstung der Maschine von einem Steckersystem zum anderen
- Max Fertigungslos ECO-TRONIC:
47 Kontaktpositionen
- Max. Fertigungslos ECO-TRONIC pro:
24 Kontaktpositionen

Features

- All versions from the respective connector systems can be processed within in one lot.
- Simultaneous processing up to five different connectors, connector types, number of ways, coding versions etc.
- Connector packaging in economical product magazines
- Manual change of product magazines.
- Option: Additional feeding unit for replacing multi row connector tubes without any machine stop.
- Processing of up to six different wires, freely programmable wire lengths
- Parallel and crossing wires as well as loops or one-side wire terminations are producible
- Quality assurance by integrated testing units and reject gate
- Manual unloading of produced harnesses
- Option: Automated harness deposit in tube magazines

Special features InTeCon ECO-TRONIC

- Machineversion to process ECO-TRONIC or ECO-TRONIC pro connector series
- Easy setup to change over from one connector system to the other
- Max. Production lot with ECO-TRONIC:
47 contact positions
- Max. Production lot with ECO-TRONIC pro:
24 contact positions

InTeCon ECO-DOMO NF

Vollautomatische IDC-Ansetzmaschinen zur Verarbeitung des Steckverbindersystems ECO-DOMO NF.
Fully automated terminating machines for connector series ECO-DOMO NF.

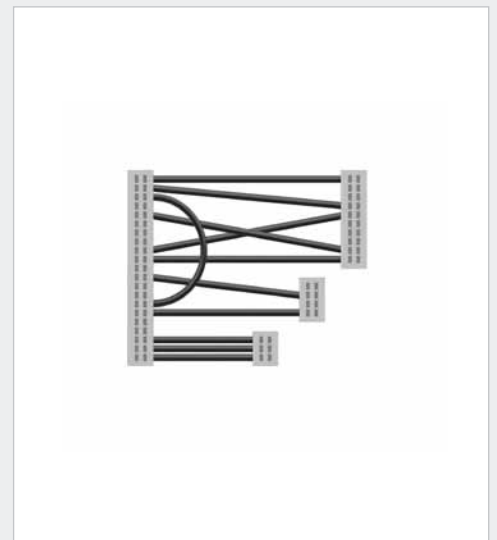

Merkmale

- Alle Versionen des jeweiligen Steckverbindersystems können in einem Fertigungslos verarbeitet werden.
- Gleichzeitige Verarbeitung von bis zu fünf unterschiedlichen Steckern, Polzahlen, Codierungsvarianten usw.
- Verpackung der Stecker in wirtschaftlichen Paketmagazinen
- Manueller Wechsel der Paketmagazine
- Optional: zusätzliche Steckerführeinheit für Magazinwechsel ohne Fertigungsunterbrechung
- Verarbeitung von bis zu sechs unterschiedlichen Leitungen, frei programmierbare Leitungslängen
- Parallele und gekreuzte Leitungen sind ebenso herstellbar wie Schlaufen und nur einseitig angeschlagene Leitungen
- Qualitätssicherung durch integrierte Prüfstationen und Ausschussweiche
- Manuelles Entladen der gefertigten Kabelbäume
- Optional: Automatische Ablage in Stangenmagazinen

Spezielle Merkmale InTeCon ECO-DOMO NF

- Maschine zur Verarbeitung des Steckverbindersystems ECO-DOMO NF, Direkt- und Indirektsteckverbinder
- Max. Fertigungslos: 24 Kontaktpositionen
- Integrierte Deckelschließstation

Features

- All versions from the respective connector systems can be processed within in one lot.
- Simultaneous processing up to five different connectors, connector types, number of ways, coding versions etc.
- Connector packaging in economical product magazines
- Manual change of product magazines.
- Option: Additional feeding unit for replacing multi row connector tubes without any machine stop.
- Processing of up to six different wires, freely programmable wire lengths
- Parallel and crossing wires as well as loops or one-side wire terminations are producible
- Quality assurance by integrated testing units and reject gate
- Manual unloading of produced harnesses
- Option: Automated harness deposit in tube magazines

Special features InTeCon ECO-DOMO NF

- Machine version to process ECO-DOMO NF connector series, direct- and indirect connector series
- Max. Production lot: 24 contact positions
- Integrated cover closing unit

STOCKOMAT CRIMP *professional line*



WT 45

Halbautomat zur Verarbeitung von Crimpkontakten in Bandform.

Semi-automatic terminating machine for crimp contacts in bandolier form.

Merkmale

- Einfache, übersichtliche Handhabung
- Automatische Artikelzuführung
- Einsatz von Schnellwechselwerkzeugen für Längs- und Quertransport mit mechanischem Artikelvorschub, Option: mit pneumatischem Artikelvorschub
- Geeignet zum Aufbau auf alle gängigen Kabelkonfektionierautomaten
- Integrierte Abisoliervorrichtung (WT 45-3)
- Option: Crimpüberwachungssystem
- Zertifikation nach CE und EMV

Technische Daten

- Maschinentaktzeit 0,3 sec.
- Leiterquerschnitt < 4 mm²
> 4 mm² auf Anfrage
- Abmessungen
B x T x H mm 300x400x760
- Pressen-Nennkraft 20 kN
- Betriebsspannung 240 V
- Luftdruck 6 bar
- Gewicht 85 kg

STOCKOMAT CRIMP mit Abisoliervorrichtung

- Maschinentaktzeit < 1 sec.
- Leiterquerschnitt 0,25-2,5 mm²
- Abmessungen
B x T x H mm 440x550x680
- Gewicht 95 kg

Main features

- Easy and clear to operate
- Automated product feed
- Suitable for quick-change tools for longitudinal and transverse transport with mechanical feed system
Optional: with pneumatic feed system
- The machine can be mounted on any automated cable-terminating machine currently on the market
- Integrated stripper device (WT 45-3)
- Optional: crimping force monitoring system
- Certification to CE and EMV

Technical data

- Cycle time 0,3 sec.
- Wire size < 4 mm²
> 4 mm² on request
- Dimensions
W x D x H mm 300x400x760
- Pressure rating 20 kN
- Operating voltage 240 V
- Pneumatics 6 bar
- Weight 85 kg

STOCKOMAT CRIMP with stripper device

- Cycle time < 1 sec.
- Wire size 0,25-2,5 mm²
- Dimensions
W x D x H mm 440x550x680
- Weight 95 kg

STOCKOMAT Crimp *professional line*

Werkzeuge

Tools



Schnellwechselwerkzeuge für Längstransport **Quick-change tools for longitudinal transport**

Schnellwechselwerkzeug für Artikel, die hintereinander angebunden sind.

Der Vorschub erfolgt mechanisch.

Diese Variante ist geeignet für die Verarbeitung von Artikeln bis max. 31 mm Transportlänge.

Option: Werkzeug mit pneumatischem Vorschub.

Quick-change tool for products which are mounted in line.

Mechanical feed system.

This version is suitable for terminating products with up to 31 mm feed length.

On option, we can provide a pneumatic feed system.



Schnellwechselwerkzeuge für Quertransport **Quick-change tools for transverse transport**

Schnellwechselwerkzeug für Artikel, die quer an den Transportstreifen angebunden sind.

Der Vorschub erfolgt mechanisch.

Diese Variante ist geeignet für die Verarbeitung von Artikeln bis max. 25 mm Transportlänge.

Option: Werkzeug mit pneumatischem Vorschub.

Quick-change tool for products which are mounted side by side on the carrier strip.

Mechanical feed system.

This version is suitable for terminating products with up to 25 mm feed length.

On option, we can provide a pneumatic feed system.

Vergleichstabellen Cross-reference lists

Umrechnung des Inch Equivalents of an Inch

Umrechnung mm in Inch Converting Millimeter to Inch

Fraction inch	Decimal inch	Millimeter mm
1/64	.015625	0.397
1/32	.031250	0.794
3/64	.046875	1.191
1/16	.062500	1.588
5/64	.078125	1.984
3/32	.093750	2.381
7/64	.109375	2.778
1/8	.125000	3.175
9/64	.140625	3.572
5/32	.156250	3.969
11/64	.171875	4.366
3/16	.187500	4.763
13/64	.203125	5.159
7/32	.218750	5.556
15/64	.234375	5.953
1/4	.250000	6.350
17/64	.265625	6.747
9/32	.281250	7.144
19/64	.296875	7.541
5/16	.312500	7.938
21/64	.328125	8.334
11/32	.343750	8.731
23/64	.359375	9.128
3/8	.375000	9.525
25/64	.390625	9.922
13/32	.406250	10.319
27/64	.421875	10.716
7/16	.437500	11.113
29/64	.453125	11.509
15/32	.468750	11.906
31/64	.484375	12.303
1/2	.500000	12.700
33/64	.515625	13.097
17/32	.531250	13.494
35/64	.546875	13.891
9/16	.562500	14.288
37/64	.578125	14.684
19/32	.593750	15.081
39/64	.609375	15.478
5/8	.625000	15.875
41/64	.640625	16.272
21/32	.656250	16.669
43/64	.671875	17.066
11/16	.687500	17.463
45/64	.703125	17.859
23/32	.718750	18.256
47/64	.734375	18.653
3/4	.750000	19.050
49/64	.765625	19.447
25/32	.781250	19.844
51/64	.796875	20.241
13/16	.812500	20.638
53/64	.828125	21.034
27/32	.843750	21.431
55/64	.859375	21.828
7/8	.875000	22.225
57/64	.890625	22.622
29/32	.906250	23.019
59/64	.921875	23.416
15/16	.937500	23.813
61/64	.953125	24.209
31/32	.968750	24.606
63/64	.984375	25.003
1	1.000000	25.400

mm	inch
0,5	.019
0,8	.031
1	.039
1,1	.043
1,2	.047
1,5	.059
1,6	.063
1,8	.070
2	.079
2,3	.090
2,5	.098
2,6	.102
3	.118
3,2	.126
3,5	.138
3,6	.141
4	.157
4,3	.169
4,5	.177
5	.197
5,5	.216
5,8	.229
6	.236
6,5	.256
6,8	.268
7	.276
7,5	.295
8	.315
8,5	.335
9	.354
9,5	.374
10	.393
10,5	.413
11	.433
11,5	.453
12	.472
12,5	.492
13	.512
13,5	.532
14	.551
14,5	.571
15	.591
15,5	.610
16	.630
16,5	.650
17	.669
17,5	.689
18	.709
18,5	.728
19	.748
19,5	.768
20	.787
20,5	.807
21	.827
21,5	.847
22	.866
22,5	.886
23	.906
23,5	.925
24	.945
24,5	.965
25	.984
25,5	1.004
26	1.024

mm	inch
26,5	1.043
27	1.063
27,5	1.083
28	1.102
28,5	1.122
29	1.142
29,5	1.161
30	1.181
30,5	1.201
31	1.220
31,5	1.240
32	1.260
32,5	1.280
33	1.299
33,5	1.319
34	1.339
34,5	1.358
35	1.378
35,5	1.398
36	1.417
36,5	1.437
37	1.457
37,5	1.477
38	1.496
38,5	1.516
39	1.535
39,5	1.555
40	1.575
40,5	1.559
41	1.614
41,5	1.634
42	1.654
42,5	1.674
43	1.693
43,5	1.713
44	1.732
44,5	1.752
45	1.772
45,5	1.792
46	1.811
46,5	1.831
47	1.850
47,5	1.870
48	1.890
48,5	1.910
49	1.929
49,5	1.949
50	1.969
50,5	1.989
51	2.008
51,5	2.028
52	2.047
52,5	2.067
53	2.087
53,5	2.107
54	2.126
54,5	2.146
55	2.165
55,5	2.185
56	2.204
69	2.716

Vergleichstabellen Cross-reference lists

Umrechnung der gängigen amerikanischen Leiter Conversion table of American Wire Sizes

AWG	Circ. Mils.	A = mm ²
26	238 - 300	0,12 - 0,15
24	315 - 477	0,16 - 0,24
22	600 - 750	0,30 - 0,38
20	1000 - 1200	0,51 - 0,61
18	1600 - 1900	0,81 - 0,96
16	2400 - 2830	1,22 - 1,43
14	3830 - 4500	1,94 - 2,28
12	6100 - 6700	3,09 - 3,40
10	9000 - 13100	4,56 - 6,64
8	13200 - 16900	6,69 - 8,56
6	22800 - 30900	11,55 - 15,66
4	38900 - 49100	19,71 - 24,88
2	60100 - 66800	30,45 - 33,85
1	75800 - 84000	38,41 - 42,56
1/0	99100 - 105800	50,21 - 53,61
2/0	124900 - 133800	63,29 - 67,80
3/0	157600 - 168000	79,86 - 85,12
4/0	198700 - 212200	100,68 - 107,52
250 - 300 MCM	250000 - 300000	117 - 151
300 - 350 MCM	300000 - 350000	151 - 192
400 MCM	400000	205
500 - 600 MCM	500000 - 600000	252 - 304

AWG = American Wire Gauge

Circ. Mils.: Der Circ. Mils.-Wert eines Kreises mit d = 1 Mil. beträgt:

$$1 \times 1 = 1 \text{ Circ. Mil. (1 Mil. = 0,001 inch = 0,0254 mm)}$$

$$1 \text{ Circ. Mil.} = 0,0005066 \text{ mm}^2$$

$$1 \text{ mm}^2 = 1973,51 \text{ Circ. Mils.}$$

Formel zur Bestimmung des Leiterquerschnittes

$$A = \frac{d^2 \cdot p}{4} \times n$$

A = Leiterquerschnitt in mm²

n = Anzahl Einzeldrähte

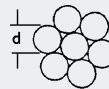

AWG = American Wire Gauge

Circular Mil Area (CMA): Area of a circle of 1 mil diameter

$$1 \times 1 = 1 \text{ Circ. Mil. (1 Mil. = 0.001 inch = 0.0254 mm)}$$

$$1 \text{ Circ. Mil.} = 0,0005066 \text{ mm}^2$$

$$1 \text{ mm}^2 = 1973.51 \text{ Circ. Mils.}$$

Formula to determine the wire size

$$A = \frac{d^2 \cdot p}{4} \times n$$

A = Wire size in mm²

n = Number of strands



»Allgemeine Sicherheitshinweise für Steckverbinder und Kontakte«

General safety information for connectors and contacts

Die Anwendungsparameter von Steckverbindern und Kontakten werden in Datenblättern und Katalogen definiert. STOCKO-Produkte sind darauf ausgelegt, innerhalb der vorgegebenen Spezifikationen betrieben zu werden. Jede Anwendung unserer Produkte außerhalb der in den Spezifikationen zugelassenen Grenzwerte kann gefährlich sein und die Nichtbeachtung der folgenden Hinweise kann deshalb schwerwiegende Folgen haben.

Eigenschaften der eingesetzten Materialien

Verwendet werden flammgeschützte thermoplastische Isolationswerkstoffe, Kontaktmaterialien auf Kupfer- oder Stahlbasis und Oberflächenbeschichtungen aus Zinn, Nickel oder Gold. In Einzelfällen, z.B. bei kundenspezifischen Produkten, können auch andere hier nicht aufgeführte Materialien zum Einsatz kommen. Die für die jeweiligen Produkte eingesetzten Materialien können je nach Anwendung variieren und auf die spezifischen Anforderungen abgestimmt sein.

Wenn die Steckverbinder und Kontakte in den in Spezifikationen und Datenblättern angegebenen Grenzen betrieben werden, bleiben die technischen Eigenschaften langfristig stabil. Werden jedoch durch besondere Betriebsbedingungen oder im Störfall die Grenzwerte überschritten oder die Steckverbinder und Kontakte z.B. extremen Umweltbedingungen ausgesetzt, können sich die Eigenschaften der eingesetzten Materialien verändern.

Die fehlerhafte Kontaktierung eines Leiters mit ungeeigneten Werkzeugen, deformierte oder gebrochene Kontakte, Überschreitung der zulässigen Strombelastung, unvollständige Steckung der Stecker und Kontakte oder schlecht gelötete Kontakte können zu einer Überschreitung der zulässigen Grenztemperatur einer Steckverbindung oder eines Kontaktes führen. In diesen Fällen kann das Isolationsmaterial in seinen elektrischen Eigenschaften beeinträchtigt werden und bei Berührung die Gefahr eines elektrischen Schlags bestehen.

Hält eine Überhitzung über die spezifizierte Grenztemperatur längere Zeit an, baut sich die Kontaktkraft der Federkontakte ab und Oxidschichten bilden sich auf Kontakten und Drähten. Der Kontaktwiderstand steigt dadurch an, weitere Temperaturerhöhungen sind die Folge und das Isolationsmaterial kann bis hin zur Verkohlung geschädigt werden. Auf Grund dieser thermischen Schädigung des Isolationsmaterials können sich Kriech- oder Leckströme bilden. Dabei können Flammen entstehen, die brennbares Material in der Umgebung entzünden und unter Umständen Brände auslösen.

Eine sorgfältige Behandlung von Steckverbindern und Kontakten auf dem Transport, in der Verarbeitung und in der Anwendung ist deshalb unbedingt notwendig. Beschädigungen können Gefährdungen nach sich ziehen. Vor dem Einbau sollten die Produkte deshalb geprüft und im Falle von fehlerhafter Verarbeitung oder vorhandener Beschädigung nicht weiterverwandt werden.

The suitability parameters for connectors and contacts are defined in the data sheets and catalogues. STOCKO products are designed to meet these specifications. To employ our products outside the specified parameters can be dangerous and neglecting the following information can have serious consequences.

Properties of the materials employed

Materials used are thermoplastic insulation materials, contact materials based on copper or steel, and tin, nickel or gold surface finishes. Under special circumstances, like products to customers' specification, also other materials than those mentioned may be used. The selected materials for individual products can vary, being tuned according to application.

Provided connectors and contacts are used within the specified limits of the data sheets, the technical properties will remain stable over a long period of time. If, however, these limits are exceeded due to special circumstances or faulty production or due to exposure to extreme environmental conditions, the properties of the materials may change.

The faulty termination of contact and conductor with unsuitable tools, deformed or broken contacts, excessive current load, unfinished connections of connectors and contacts or badly soldered contacts can lead to exceeding the permissible temperature range of the connector or contact. In such event the insulating material may be impaired and, if touched, the danger of electric shock may exist.

Over-heating due to exceeding the specified temperature limits over a longer period will result in a reduction of the contact force of contacts and an oxide layer will build up on contacts and conductors. The contact resistance will increase and further temperature rises will result in damaging the insulating material with the danger of charring. Creeping or leakage currents can be formed owing to the thermal damaged insulation. This may cause combustion that ignites the surrounding inflammable material and may even start a fire.

A careful handling of connectors and contacts in all stages of transport, manufacture and application is absolutely important. Damaged components can create dangers. The products, therefore, should be examined before assembly and must not be further processed, if badly terminated or defective.



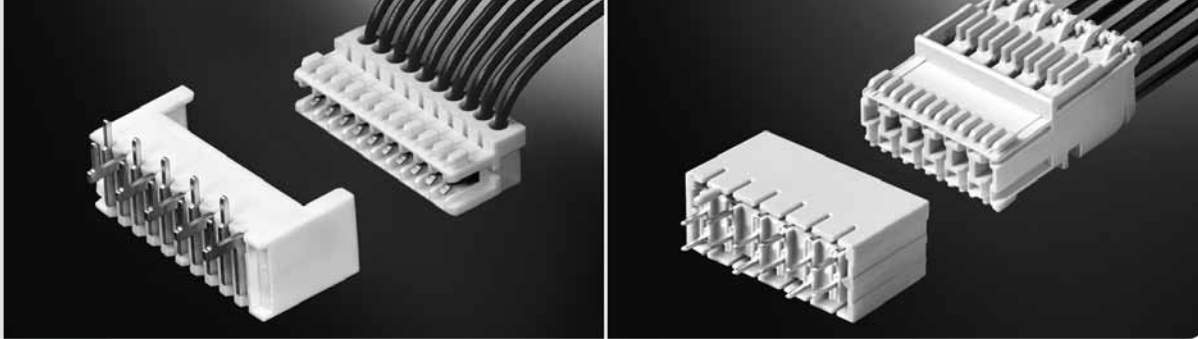

Verarbeitung / Kabelbaumherstellung

Nur sorgfältig verarbeitete Steckverbinder und Kontakte erfüllen in der Anwendung die technischen Anforderungen. STOCKO-Ansetzwerkzeuge und -Maschinen sind auf die besonderen Produkteigenschaften abgestimmt. Prüfstationen überwachen die Qualitätsparameter, um eine hochwertige Verarbeitung der Steckverbinder und Kontakte sicherzustellen.

Für die Einhaltung der STOCKO-Qualitätskriterien auf Verarbeitungseinrichtungen anderer Hersteller trägt der Anwender die alleinige Verantwortung.

- Nur geschultes Personal sollte Steckverbinder und Kontakte verarbeiten.
- Bei der Verarbeitung von Steckverbindern und Kontakten müssen die STOCKO-Verarbeitungsspezifikationen berücksichtigt werden.
- Die Überwachung der produktspezifischen Qualitätsparameter muss nach STOCKO-Vorgaben erfolgen.
- Die eingesetzten Leitungen müssen von STOCKO für das jeweilige Steckverbindersystem oder den Kontakt freigegeben sein.
- Stellen Sie sicher, dass die Isolationsfähigkeit des Steckers nicht durch niederohmige Verbindungen wie Metallspäne, leitende Betriebsstoffe, lose Litzen oder leitende Verunreinigungen herabgesetzt ist, bevor die Stromkreise eingeschaltet werden.

Steckverbinder und Kontakte in der Anwendung

In der Anwendung muss sichergestellt werden, dass die Steckverbinder und Kontakte spezifikationsgemäß eingesetzt werden.

- Die bestimmungsgemäße Funktion einer steckbaren Verbindung wird nur gewährleistet, wenn die Verbindung nach den Vorgaben montiert ist.
- Die zulässige Betriebsspannung hängt von der jeweiligen Anwendung, den gültigen nationalen Bestimmungen und anderen anwendbaren Sicherheitsbestimmungen ab. Die angegebene Betriebsspannung kann deshalb nur als Anhaltswert dienen und muss mit den nationalen Bestimmungen abgeglichen werden.
- Die in den Datenblättern und Spezifikationen angegebenen Temperaturwerte sind Grenztemperaturen und dürfen in der Anwendung nicht überschritten werden.
- Eine Verschmutzung der Steckverbinder und Kontakte darf den jeweils zulässigen Verschmutzungsgrad nicht überschreiten (siehe IEC 60 664). Leitende Verschmutzungen können Kriechströme verursachen. Dabei können Flammen entstehen, die brennbares Material in der Umgebung entzünden und Brände auslösen können.
- Eingeschaltete Stromkreise dürfen nicht durch Abziehen eines Steckers unterbrochen werden. Lichtbögen, Ionisation und ein Brand kann die Folge sein.
- Die Steckverbinderkomponenten mit berührbaren Kontakten sollten nicht auf der Stromversorgungsseite eingesetzt werden, da bei ungesteckten Verbindungen die Gefahr eines elektrischen Schlags besteht.

Sonstige Hinweise

Durch den ständigen Verbesserungsprozess können sich die Produkte ändern. Abweichungen von Beschreibungen, technischen Daten und Darstellungen in den Katalogen sind deshalb möglich. Jede neue Ausgabe eines Kataloges macht vorausgehende Ausgaben ungültig.

Processing / Cable Loom Assembly

Carefully processed connectors and contacts alone will meet the technical requirements in usage. STOCKO assembly tools and machines are adjusted to the specific product properties. Test stations control the quality parameters to safeguard the quality in processing the connectors and contacts.

To assure the STOCKO-quality requirements on processing devices of other manufacturers the user has to take sole responsibility.

- Only trained personnel should process connectors and contacts.
- Processing connectors and contacts the STOCKO manufacturing specifications must be observed.
- Product specific quality parameters must be controlled in accordance with STOCKO instructions.
- Conductors used with the respective connector system or contact must be approved by STOCKO.
- Before switching on the electric current, make sure that the insulating properties of the connector are not compromised by low ohmic connections like metal shavings, conductive materials, lose wires or conductive impurities.

Application of connectors and contacts

When in use make sure that connectors and contacts are applied according to specification.

- The pre-determined function of a connector assembly can only be guaranteed if the connection is assembled according to instruction.
- The permissible operating voltage is subject to application, the legal national specifications and any other applicable safety requirements. The mentioned operating voltage can only serve as a guidance and must be adjusted to national requirements.
- The temperature values indicated in the data sheets are border-line temperatures and must not be surpassed under operating conditions.
- Contaminated connectors and contacts must not exceed the permissible degree of contamination (see IEC 60 664). Conductive contaminations can lead to creepage currents. They can create combustions that inflame surrounding inflammable materials and start fires.
- Switched-on circuitry must not be interrupted by pulling the plug. The result may be electric arcs, ionisation and fires.
- Connector components with touchable contacts must not be used as mains connections as unplugged connections can endanger electric shocks.

Further Information

The products can be changed due to improvements. Changes and alterations from descriptions, technical data and illustrations in the catalogues are possible. Every new catalogue will make all earlier published versions invalid.

Kontaktadressen Contact addresses

- D Distribution / Distribution
P Zweigwerk / Plant
R Vertretung / Representation
S Tochtergesellschaft / Subsidiary
SD Vertriebsbüro / Sales Office

Deutschland / Germany

- Hauptsitz STOCKO Contact GmbH & Co. KG
Simonshöfchen 31
42327 Wuppertal
Tel.: +49 / (0)202 / 97 33 - 0
Fax: +49 / (0)202 / 97 33 - 411
E-Mail: info@stocko-contact.com
- P STOCKO Contact GmbH & Co. KG
Olefalstr. 26
53940 Hellenthal
Tel.: +49 / (0)2482 / 84 - 0
Fax: +49 / (0)2482 / 84 - 240
E-Mail: hellenthal@stocko-contact.com
- D BAUM electronic GmbH
Schieferstein 6
65439 Flörsheim / Main
Tel.: +49 / (0)6145 / 50 56 - 0
Fax: +49 / (0)6145 / 50 56 - 40
E-Mail: info@baum-electronic.de
- D HZ GmbH
Technische Kunststoffe & Elektrische
Verbindungstechnik
Kuchengrund 20
71522 Backnang
Tel.: +49 / (0)7191 / 32 81 - 0
Fax: +49 / (0)7191 / 32 81 - 29
E-Mail: mail@hz-gmbh.com
- R Hoppe & Co. Electronic
Inhaber Hans Zeltner e.K.
Gaismannshofstraße 38
90431 Nürnberg
Tel.: +49 / (0)911 / 32 71 75
Fax: +49 / (0)911 / 32 71 41
E-Mail: info@hoppe-electronic.de
- D zeb elektroTECHNIK GmbH
Gaismannshofstraße 38
90431 Nürnberg
Tel.: +49 / (0)911/32 39 57-0
Fax: +49 / (0)911/32 71 41
E-Mail: info@zeb-gmbh.de
- D ETB Electronic Team
Beratungs- und Vertriebs GmbH
Wundramweg 1
31303 Burgdorf
Tel.: +49 / (0)5136 / 9 72 29-0
Fax: +49 / (0)5136 / 9 72 29-39
E-Mail: info@etb-electronic.de

Australien / Australia

- D Braemac Pty Ltd
1/59-61 Burrows Road, Alexandria
Sydney, NSW 2015 Australia
Tel.: +61 / 2 / 95506600
Fax: +61 / 2 / 95506377
E-Mail: info@braemac.com.au

Belgien und Luxemburg / Belgium and Luxembourg

- R ATEM N.V./S.A.
Bedrijvenpark De Veert 4
B-2830 Willebroek
Tel.: +32 / 03 / 866 18 00
Fax: +32 / 03 / 866 18 28
E-Mail: info@atem.be

Belarus

- D FEK Company
29b, Pushkina pr-t
220015 Minsk
Belarus
Tel.: +375 / 17 / 210 2189
Fax: +375 / 17 / 210 2189
E-Mail: info@fek.by

Brasilien, Argentinien, Uruguay, Paraguay Brazil, Argentina, Uruguay, Paraguay

- R STOCKO do Brasil Ltda.
Eng. Jorge Vukotich
Rua Américo Brasiliense, 1400 - Cj.: 123
CEP 04715-002 - São Paulo - S.P. - Brasilien
Tel.: +55 / 11 / 5524 2041
+55 / 11 / 4323 0095
Mobil: +55 / 11 / 8308 3031
Fax: +55 / 11 / 4323 0096
E-Mail: vukotich@stocko.com.br

China / China

- R STOCKO Contact GmbH & Co. KG
c/o Wieland Electric
Trading (Shanghai) Co. Ltd.
Unit 2703 Int'l Soho City
889 Renmin Rd, Huang Pu District
PRC-Shanghai 200010
Tel.: +86 / 21 / 63555772-126
63555772-127
Fax: +86 / 21 / 6355 0090
Mobil: +86 - 136 3643 5222
E-Mail: info@stocko-contact.cn
- SD STOCKO Contact GmbH & Co. KG
#3-601, No.42 Dongshan 4th Road,
Qingdao 266100, P.R.China
Mobil: +86 / 139 6976 0609
Fax: +86 / 532 / 6687 0622
E-Mail: info@stocko-contact.cn
- SD STOCKO Contact GmbH & Co. KG
Room 506,
No. 3 Building of Taoranju Community
Nanshan District
Shenzhen 518055, P.R.China
Mobil: +86 / 138 2378 9179
Fax: +86 / 755 8255 1978
E-Mail: info@stocko-contact.cn

- SD STOCKO Contact GmbH & Co. KG
Unit 27-1-401, No.184 Taishan Road
New district Changzhou 213022,
P.R.China
Mobil: +86 / 136 8521 6240
Fax: +86 / 0519 8805 0927
E-Mail: info@stocko-contact.cn

- D SIC ELECTRONICS CO. LTD
No.2 factory building,
Export Process Area,
Huanghe East Road
Qingdao Economic & Technical
Development Zone, P.R.China
Postal Code 266555
Tel.: +86 / 750 / 3236 6258
E-Mail: sales@sicchina.com.cn

- D WG Industrial Control Equipment
Suit. 112, No. 838, Beisong RD
Minhang District
201111 Shanghai, P.R.China
Tel.: +86 / 21 / 34 53 36 71
Fax: +86 / 21 / 34 31 13 61
E-Mail: sales@wg-ind.com

Dänemark / Denmark

- R D Matech Systems ApS
Ankelbovej 6
DK-7190 Billund
Tel.: +45 / 75 33 89 49
Fax: +45 / 75 33 89 46
E-Mail: info@matechsystems.dk

Estland, Lettland, Litauen / Estonia, Latvia, Lithuania

- R Adcontact/Gammeter
Paldiski mnt 31
EE - 76606 Keila, Harjumaa
Tel.: +372 / 671 2251
Fax: +372 / 671 2253
Mobil: +372 / 50 89343
E-Mail: info@gammeter.ee

Finnland / Finland

- R Adcontact/Gammeter
Naulakatu 3
P.O. Box 627
FIN-33101 Tampere
Tel.: +358 / 3 / 380 22 11
Fax: +358 / 3 / 380 22 44
E-Mail: info@gammeter.fi

Frankreich / France

- S STOCKO CONTACT Eurl
7, Route d'Eichhoffen
B.P. 40017 Andlau
67145 - BARR Cedex
Tel.: +33 / (0)3 / 88 58 58 58
Fax: +33 / (0)3 / 88 58 58 88
E-Mail: andlau@stocko-contact.com
- R M. Roland DOTIGNY
4 Rue Rougette
60240 Liancourt St Pierre
Tel.: +33 / (0)3 / 44 47 91 68
Fax: +33 / (0)3 / 44 47 91 68
E-Mail: roland.dotigny@stocko-contact.com
(Normandie / Parisienne)

- R D CONNECT-SYSTEMES
31, Impasse de la Balme
69800 Saint-Priest
Tel.: +33 / (0) 478 901 315
Fax: +33 / (0) 478 906 332
E-Mail: commercial@connect-systemes.fr
(Rhône-Alpes, Sud, Centre, Est)

Griechenland / Greece

- R S. SAKELLIU & CO O.E.
Manufacturer's Agents
15B Konstantinidou str.
K. Patissia 104 45 - Athens
Tel.: +30 / 210 / 83 22 611
Fax: +30 / 210 / 83 25 444
E-Mail: sasta@on.gr

Großbritannien / Great Britain

- D Cabletrix Ltd
9/10 James Watt Close
Drayton Field Industrial Estate
Daventry, Northants NN11 5QU, UK
Tel.: +44 / 1327 / 876769
Fax: +44 / 1327 / 300130
E-Mail: sales@cabletrix.co.uk

- D J-Tronics Ltd
1 Granger Avenue
Acomb
York, YO26 5LF, UK
Tel.: +44 / 1904 / 795690
Fax: +44 / 1904 / 790887
E-Mail: julie@j-tronics.co.uk
If you need a design partner for harnesses
contact: gareth@j-tronics.co.uk

- D New Force Ltd
Unit 6, Larkstore Park
Lodge Road
Staplehurst
Kent, TN12 0OY, UK
Tel.: +44 / 1580 / 895111
Fax: +44 / 1580 / 895222
E-Mail: sales@new-force.co.uk

Kontaktadressen Contact addresses

(D) Distribution / Distribution
(P) Zweigwerk / Plant
(R) Vertretung / Representation
(S) Tochtergesellschaft / Subsidiary
(SD) Vertriebsbüro / Sales Office

Indien, Pakistan, Sri Lanka, Bangladesch, Nepal, Bhutan India, Pakistan, Sri Lanka, Bangladesh, Nepal, Bhutan

(D) Sahajanand Impex Pvt. Ltd.
103/104, Magnum Opus,
Shantinagar, Vakola,
Santacruz (East)
Mumbai - 400 055, India
Tel.: +91 / 22 / 66925151
Fax: +91 / 22 / 66921026
E-Mail: sales@sahajanand.com

Irland, Republik / Republic of Ireland

(D) EirKen Enterprises Ltd.
247 Riverforest
Leixlip
Co Kildare, Ireland
Tel.: 00353/1/6156705
Fax: 00353/1/6156704
E-Mail: americ@eirken.ie

Italien / Italy

(R) **(D)** KLEMI Contact Srl
Via G. Marcora, 13
I-20097 Milano
Tel.: +39 / 02 / 55 60 61 01
Fax: +39 / 02 / 55 60 71 34
E-Mail: klemi@klemi-contact.com

(D) Comarel S.n.c.
Via Montepulciano, 17
I-20124 Milano
Tel.: +39 / 02 / 67 60 611
Fax: +39 / 02 / 67 01 624
E-Mail: comarel@comarel.com

Kanada / Canada

(R) WIELAND Electric Inc.
2889 Brighton
Road Oakville, Ontario L6H 6C9
Tel.: +1 / 905 / 829 84 14
Toll Free: +1 / 800-WIELAND
Fax: +1 / 905 / 829 84 13
E-Mail: oakville@wielandinc.com

Korea / Korea

(D) Sam Tra International
Hoseo Venture Tower 609 Ho
319 Gasan-dong
Geumcheon-gu, Seoul 153-711
Korea
Tel.: +82 / 2 / 26275625
Fax: +82 / 2 / 26275629
E-Mail: sales@samtra.co.kr

Kroatien, Slowakei, Slowenien, Tschechien Croatia, Slovakia, Slovenia, Czechia

(via Codico Partner)

(D) CODICO GmbH
Zwingenstraße 6-8
A-2380 Perchtoldsdorf
Tel.: +43 / 01 / 8 63 05-0
Fax: +43 / 01 / 8 63 05-5000
E-Mail: office@codico.com

Mexiko / Mexico

(SD) STOCKO CONTACT GmbH & Co. KG
Sales Office North America
49 International Road
Burgaw, N.C. 28425
Tel.: +1 / 910 / 259 5050
Fax: +1 / 910 / 259 3691
E-Mail: info@wielandinc.com

Norwegen / Norge

(R) **(D)** Adcontact/Gammeter
P.O. Box 246 Skøyen
N-0213 Oslo
Tel.: +47 224 177 00
Fax: +47 224 177 01
E-Mail: info@adcontact.se

Österreich / Austria

(D) CODICO GmbH
Zwingenstraße 6-8
A-2380 Perchtoldsdorf
Tel.: +43 / 01 / 8 63 05-0
Fax: +43 / 01 / 8 63 05-5000
E-Mail: office@codico.com

Polen / Poland

(R) **(D)** EVOLTEC Tomasz Pawlowski
ul. Postepu 1
02-676 Warszawa
Tel.: +48 / 022 / 8474999
Fax: +48 / 022 / 4907611
E-Mail: info@evoltec.pl

Portugal / Portugal

(R) E. Kramer, LDA.
AP. 3096
Leça da Palmeira
P-4456 Matosinhos
Tel.: +351 / 022 / 9964585
Fax: +351 / 022 / 9964588
E-Mail: ekramerlda@mail.telepac.pt

Russland / Russia

(D) Connectors & Engineering KG
Krasnokazarmennaya 3 build 5
Moscow 111250
Russia
Tel.: +7 / 495 967 15 60
Fax: +7 / 495 967 15 61
E-Mail: sales@faston.ru

(D) ELCO Group LLC
13A, Building 4, Structure 4
Varshavskoye Shosse
Moscow 115230
Tel.: +7 / 495 981 8516
Fax: +7 / 495 775 0255
E-Mail: info@elcogroup.ru

Weißrussland / Belarus

(D) FEK Company
29b, Pushkina pr-t
220115 Minsk
Belarus
Tel.: +375 / 17 / 210 2189
Fax: +375 / 17 / 210 2189
E-Mail: info@fek.by

Schweden / Sweden

(R) **(D)** Adcontact/Gammeter
Ursviksv. 127B
P.O. Box 7044
S-17407 Sundbyberg
Tel.: +46 / 8 / 445 36 00
Fax: +46 / 8 / 445 36 10
E-Mail: info@adcontact.se

Schweiz / Switzerland

(R) **(D)** AWAG Elektrotechnik AG
Sandbühlstrasse 2
CH-8604 Volketswil
Tel.: +41 / 044 / 908 1919
Fax: +41 / 044 / 908 1999
E-Mail: info@awag.ch

Singapur / Singapore

(SD) STOCKO CONTACT GmbH & Co. KG
Liason Office Singapur
Blk 5, Rivervale Crescent
08-05 Singapore 545084
Mobile: +65 / 91 83 21 31
E-Mail: danny.lee@stocko-asia.com

(D) STOCKO Electronics
Asia Pacific Pte. Ltd.
16 New Industrial Road
01-03/04 Hudson Technocentre
Singapore 536204
Tel.: +65 / 6 345 1788
Fax: +65 / 6 348 61 16
E-Mail: info@stocko.com.sg

Spanien / Spain

(SD) STOCKO CONTACT GmbH & Co. KG
Vertriebsbüro Spanien
F. Rius i Taulet, 19-3°
E-08850 Gavà (Barcelona)
Tel.: +34 / 936 / 627 188
Fax: +34 / 936 / 627 188
Mobil: +34 / 676 490 974
E-Mail: diego.vazquez@stocko-contact.de

(D) Otto Rating S.A.
Castellnou, 31-33
E-08017 Barcelona
Tel.: +34 / 93 / 252 27 00
Fax: +34 / 93 / 205 62 64
E-Mail: info@rating.es

Südafrika / South Africa

(R) APT Advanced Product Technology (PTY)
LTD.
Strijdom Park, Randburg
P.O. Box 832
Ferndale 2160
Tel.: +27 / 11 / 792 6010
Fax: +27 / 11 / 792 9879
E-Mail: craig@aptsa.co.za

Türkei / Turkey

(SD) STOCKO CONTACT GmbH & Co. KG
Istanbul Liason Office
Atakoy 11. Kisim, Cigdem D Blok, D:33
34158 Istanbul / TURKIYE
Tel.: +90 / 212 / 661 87 10
Fax: +90 / 212 / 661 87 20
E-Mail: info@stockotr.com

Ungarn / Hungary

(R) **(D)** CZINEGE és FIAI Kft.
Pesti ucta 36,
H-5100 - Jászberény
Tel.: +36 / 057 / 500 190
Fax: +36 / 057 / 500 191
E-Mail: czinege@czinege.hu

USA

(SD) STOCKO CONTACT GmbH & Co. KG
Sales Office North America
49 International Road
Burgaw, N.C. 28425
Tel.: +1 / 910 / 259 5050
Fax: +1 / 910 / 259 3691
E-Mail: burgaw@stocko-contact.com

STOCKO CONTACT GmbH & Co. KG

Simonshöfchen 31
D-42327 Wuppertal

Tel. ++49 (0)202 / 97 33 - 0
Fax ++49 (0)202 / 97 33 - 411

e-mail info@stocko-contact.com
Internet www.stocko-contact.com

Ein Unternehmen der Wieland Gruppe
A Member of the Wieland Group



Wuppertal / Deutschland

Andlau / Frankreich

Hellenthal / Deutschland



Ref. Nr. 378421
Printed in Germany 6 / 12

