

## Modal

**M20** ■ Force outputs from 49N to 12

**M50** ■ Bearing guidance

**M100** ■ Virtually zero axial stiffness

**M200**

**M350**

**Inertial** ■ Force outputs from 30N to 250N

**IV40**

**IV45** ■ Tunable suspension to produce peak force at low resonant frequencies

**IV46**

**IV47** ■ Options for cooling by airline or by standard blowers



The M series of modal shakers use linear bearings, in place of the more common suspension systems, to produce virtually zero axial stiffness and virtually zero mechanical damping. When combined with Data Physics' linear amplifiers, operating in current mode, the resultant system force output will exhibit typically less than 1% electrical damping and the phase shift between drive current and force output will be typically less than 1°.

When large structures need to be tested, inertial shakers provide the ideal solution. The central spigot is attached to the structure under test and the body then provides the inertial mass. These shakers have found applications for testing buildings, floor loading resonances, ship's decks for helicopter loading, squeaks and rattle testing in cars, geological exploration, helicopter rotor simulation and active vibration cancellation

**SignalForce**

	Maximum Sine Force			Maximum Velocity		Rated Travel Peak to Peak		Spigot Diameter		Moving Mass		Spigot Threads	Frequency Range		Electrical Power Consumption
	lbf	N	kgf	ips	mps	in.	mm	in.	mm	lbs.	kg		Metric	Minimum	
<b>Modal Shakers</b>															
M20/PA100EC	18	80	8.2	60	1.52	1.0	25.4	0.6	14.5	0.4	0.19	M6	DC	1000	0.1
M50/PA300E	54	240	24.5	60	1.52	1.0	25.4	0.9	23.8	1.0	0.45	M6	DC	1000	0.6
M50/PA1000E	74	330	33.7	60	1.52	1.0	25.4	0.9	23.8	1.0	0.45	M6	DC	1000	1.5
M100/PA300EC	100	444	45.3	60	1.52	1.0	25.4	0.9	23.8	1.5	0.68	M8	DC	1000	2.1
M100/PA1000EC	150	666	67.9	60	1.52	1.0	25.4	0.9	23.8	1.5	0.68	M8	DC	1000	2.9
M200/PA1000EC	275	1225	124.9	60	1.52	1.0	25.4	1.0	26	3.0	1.36	M8	DC	1000	3.7
M350/PA1000EC	475	2115	215.7	60	1.52	1.0	25.4	2.0	50	6.8	3.1	M12	DC	1000	5.5

	Maximum Sine Force			Inertial Mass		Spigot Threads	Spring Mass Resonance	Electrical Power Consumption
	lbf	N	kgf	lbs.	kg			
<b>Inertial Shakers</b>								
IV40/PA30E	7	30	3.1	2.7	1.21	M6	30	0.1
IV45/PA30E	11	50	5.1	9.3	4.2	M8	21	0.1
IV46/PA100E	38	170	17.3	32.0	14.5	M12	22	0.2
IV47/PA300E	56	250	25.5	32.0	14.5	M12	20	0.6

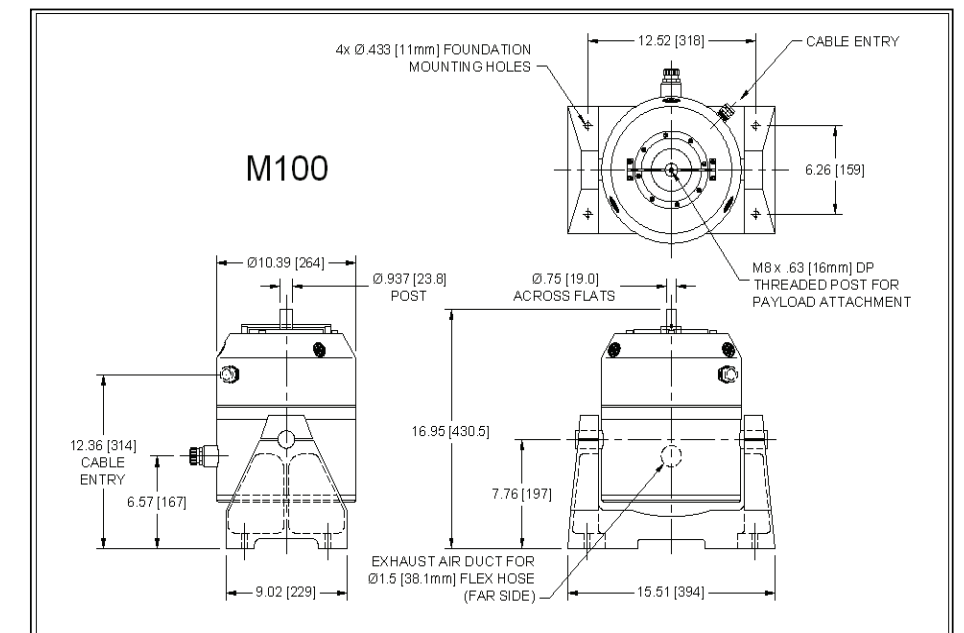
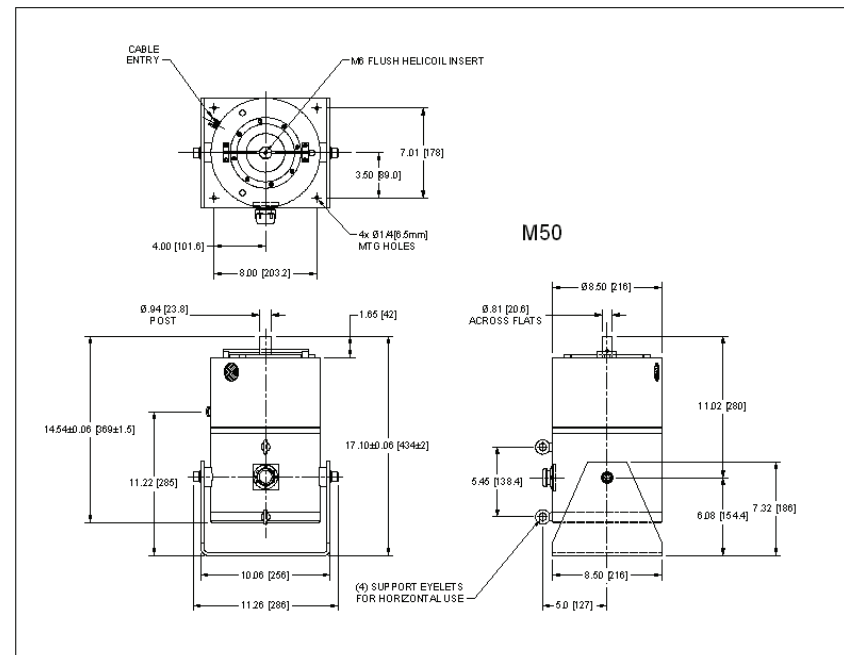
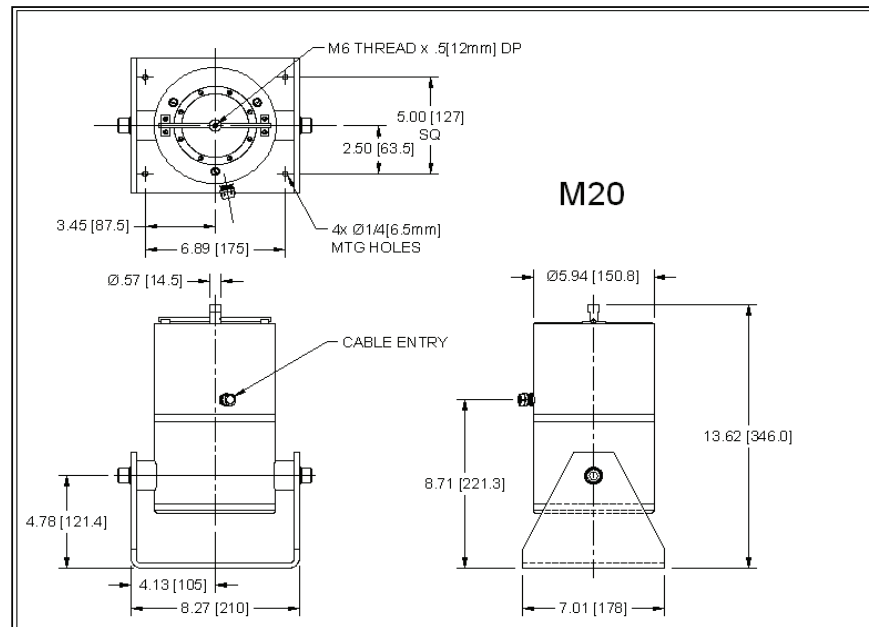
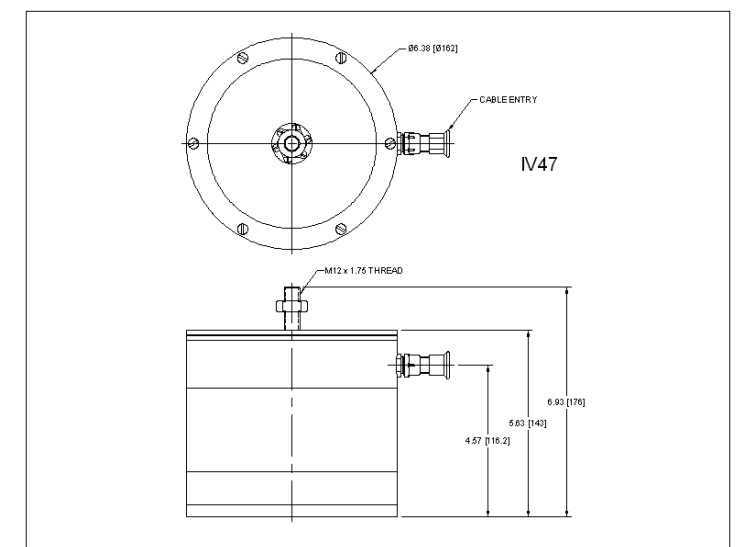
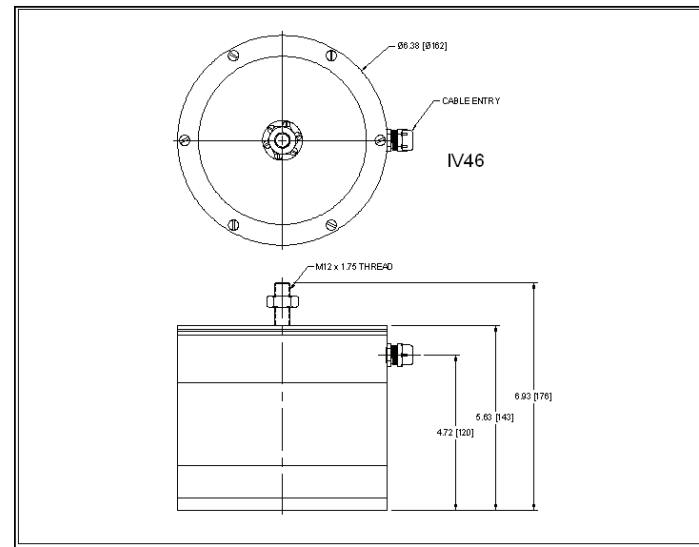
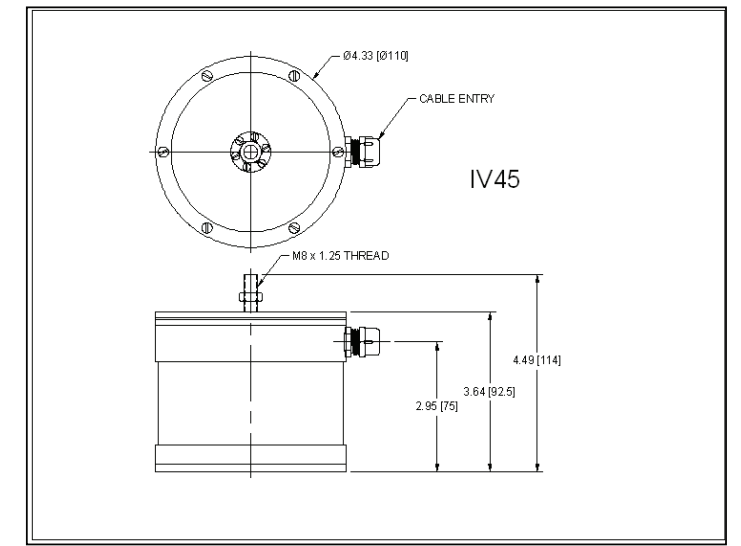
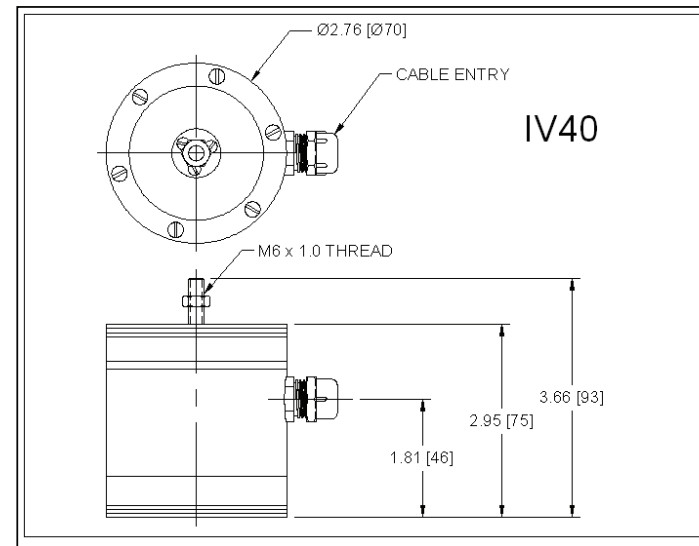

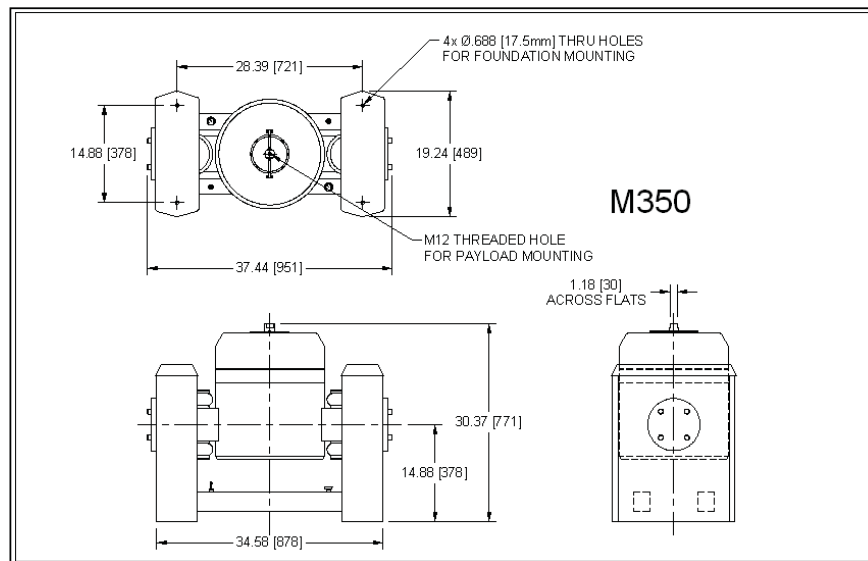
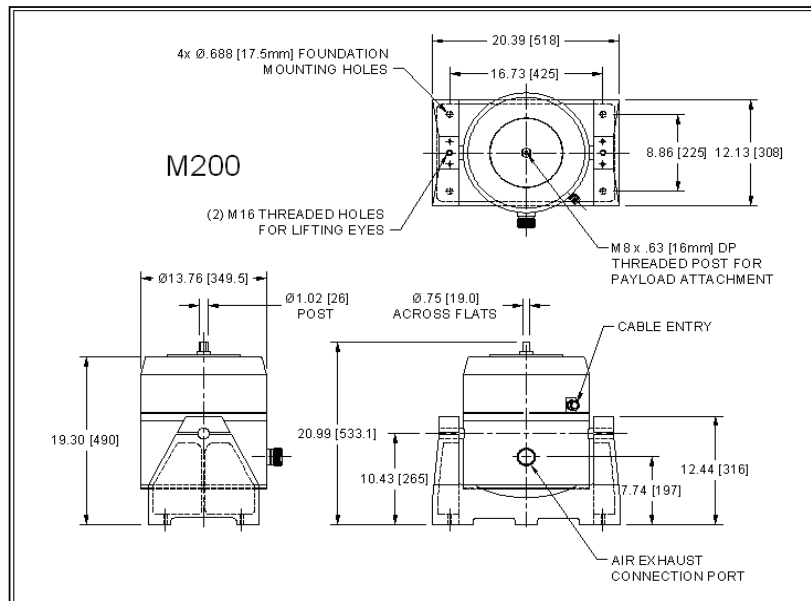

## Inertial Shakers

The spring mass resonant frequency is determined by the stiffness of the installed suspension units. The above table shows the spring mass resonant frequency for standard units, however, customers may specify any frequency over the range 12Hz to 60Hz as an option. A manufacturing accuracy of better than 2Hz can be obtained. The full force is produced at the spring mass resonant frequency and this may be much higher than the rated output. Inertial shakers are permanent magnet devices which may be sealed for short test operations in harsh environments. For prolonged use it is necessary to cool the shakers and this can be achieved either by the attachment of a standard shop dry air line or by the attachment of a small cooling blower to suck the air through the shaker. All power amplifiers used with inertial shakers may be fitted with an internal sine signal source to provide simple excitation for the shaker. Externally generated signals may also be applied to the power amplifier.



Discover more at [www.dataphysics.com](http://www.dataphysics.com)

### Data Physics Corporation

1741 Technology Drive, Suite 260, San Jose, CA 95110  
 TEL: (408) 437-0100 FAX: (408) 437-0509

