



SUURMOND



AUTOCCLAVE



SUURMOND

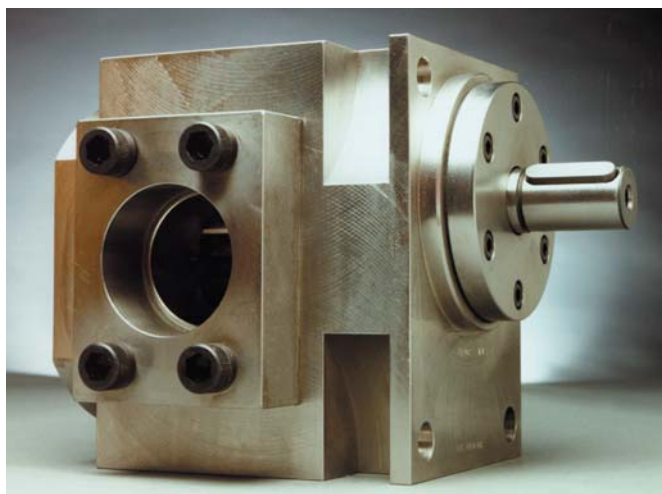

Maag Cinox gear pump for the chemical industry.

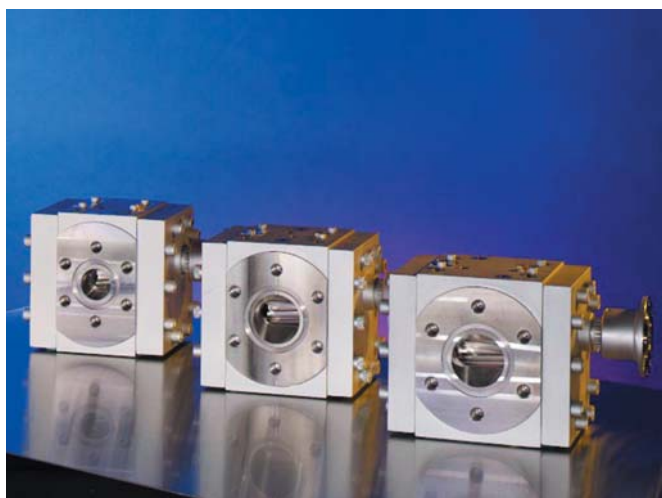

Maag Extrex gear pump for the extrusion industry.

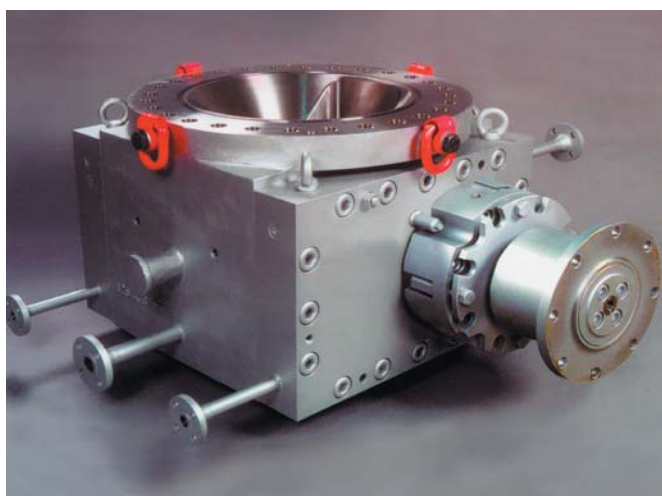

Maag Vacorex gear pump for the polymer industry.

PROFILE

SUURMOND is an independent advising and engineering company in the field of chemical processing, the pharmaceutical and the plastics industry and has been active since 1974 in the Benelux and since 2004 in the UK.

SUURMOND supplies pumps, polymer filters, screen changers, control systems, gear boxes, thin film evaporators, pelletizing systems and static mixers of a number of leading brands. Suurmond also supplies pump units and complete dosing and metering systems.

These products are used in the chemical, petrochemical, polymer, pharmaceutical, food and plastics industry.

The division **AUTOCLAVE** – since January 2003 part of Suurmond – concentrates on glass and metal (pressure) reactors, mini plants and laboratory equipment for research & development departments in (polymer) chemistry, pharmacy and bio-industry in the Benelux countries.

PORTFOLIO

SUURMOND supplies gear pumps for various applications; from small to large, temperatures from -30° C up to +350° C, viscosities of 0,4 mPas to 30 million mPas and pressures up to 750 bar and even modular inert pumps. The number of applications keeps expanding with innovations of our suppliers. Various side products also belong to the scope of supply.

AUTOCLAVE supplies a broad range of equipment for chemical development and scale-up, varying from (pressure) reactors – also inert examples – with volumes from 10 ml up to 100 l, to automation, process safety and cooling and heating units. Besides that chemreactors from 50 to 2000 l and complete glass production plants – up to NW 400 – can be custom-made designed and supplied for distillation applications.

FACILITIES

SUURMOND disposes of the following facilities and possibilities:

- Skilled service engineers
- Workshop for repair of pumps and assembly
- Stock pump spare parts for chemical and extrusion pumps
- 24/24 hour availability by contract
- Welding qualifications/cooperation with a specialized company with ISO 9001
- Trained personnel for trouble shooting and start-up

SUURMOND

- chemical industry
- polymer industry
- extrusion industry

applications:



Lubrication oil circulation system.



Complete engineered system for processing recipes.



VTA thin film evaporator.

AUTOCLAVE

- chemical industry
- pharmaceutical industry

applications:



Büchi Chemreactor CR-162 and single Büchiflex couplings; pharmaceutical kilo plant with a feed vessel, product coolers/ condensers, phase separators and collectors. Stainless steel scaffolding. No compensator necessary.

Fully GMP conform.

Inset: Büchiflex coupling



Büchi Kiloclave with 5 and 10 ltr vessel, 60 bar, 250°C, Huber closed cooling and heating unit, tailor made Autoclave measuring and control unit controlled by PC, datalogging.

ATEX certified.

Inset: coverplate of the Kiloclave.

AUTOCLAVE

START-UP ASSISTANCE

The quickest and safest way to start up your newly purchased equipment, is to have **SUURMOND** perform the installation and start-up procedures.

Ask **SUURMOND** for the possibilities and profit from the gain in time.

EDUCATION

For optimal handling of high grade products, **SUURMOND** advises its customers extensively about the application and installation of the supplied goods. Education can also be part of the scope of supply. Of course education will preferably take place at the customer's site, so that all necessary equipment is available.

Learn the possibilities from your **SUURMOND** contact.

ASSEMBLY

SUURMOND has a fully equipped workshop with well educated personnel (VCA certified, equivalent to Safety, Health and Environment) to assemble units and to adapt products to suit the customers needs.

CONTRACTUAL MAINTENANCE

Maintenance is an important issue but not only for carrying out repairs. Preventative maintenance combined with a maintenance plan will result in better performance, lower costs and lower costs of ownership. Consider your needs and **SUURMOND** will make a becoming proposal.

CERTIFICATION

SUURMOND is able to deliver according to the following standards:

- API 613/676/610
- ANSI / ASA / ASTM / ASME
- AGMA
- ATEX
- DIN / BS / ISO
- VCA (equivalent to Safety, Health and Environment)
- CE
- TÜV



Mini reactors by Büchi; Tynyclave and Miniclave.
Volumes 10-500 ml, max. 60 bar. With optional fast action closure.

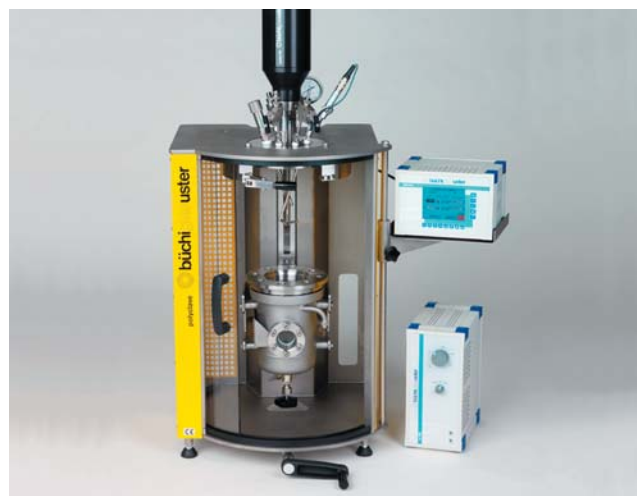

Modular pressure reactor system Polyclave by Büchi.
Vessels up to 5 liter. With optional lift and fast action closure.



High pressure reactor Limbo Li by Büchi.
With lift. Max. 350 bar, 350°C. Including temperature control.

SUURMOND

AUTOCCLAVE

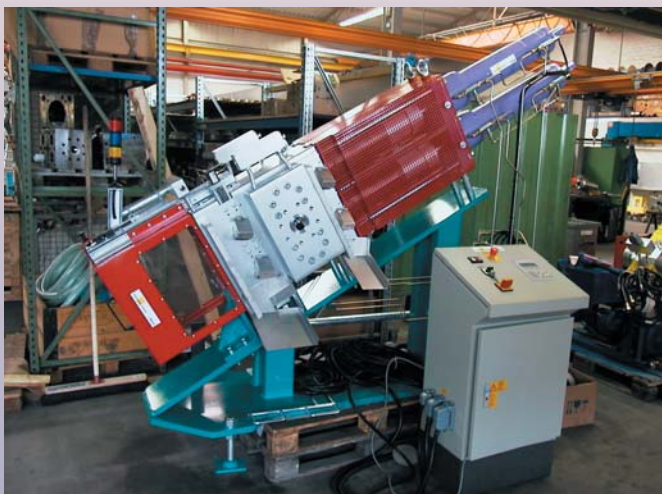

Maag process constant, backflush screen changer, CSC148-BF-4F. Active screen area 692 cm², max. output ± 1100 kg/h.



Flexylab by Systag; parallel synthesis with up to 6 reactors.

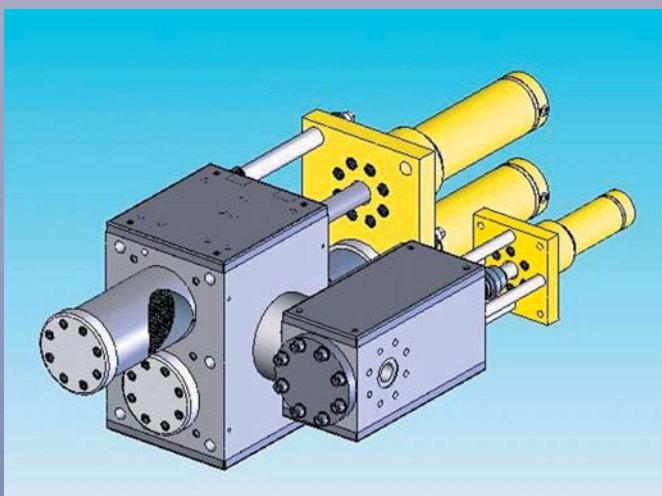

Maag CSC-CP screen changer for continuous constant pressure and processing.

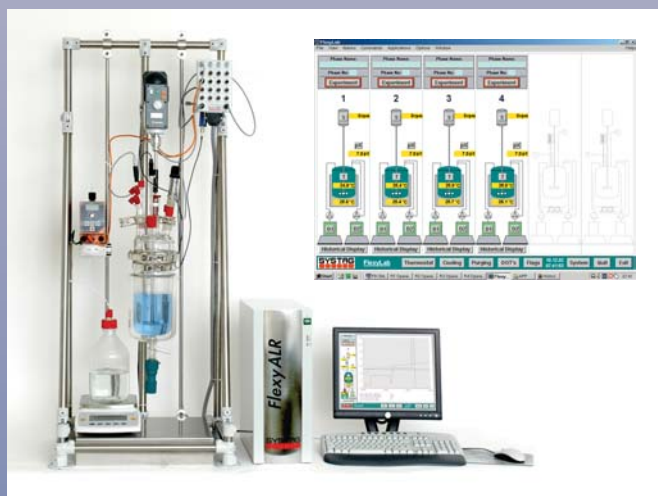

Flexy ALR by Systag; single reactor automation, up to 6 reactors. Inset: screen of the Systag Flexy concept; modular automation system for all Systag applications.



Resotec, Redis 420, tailor made control system for complete extrusion lines.



Large glass construction by Büchi, pilot plant and production scale. Options: SiC heat exchanger, gas scrubber, mixing vessel, etc.

THE NETHERLANDS:

SUURMOND BV

Voltweg 9
P.O. Box 125
8070 AC Nunspeet
The Netherlands

T +31 (0)341 - 254900
F +31 (0)341 - 258484

www.suurmond.com
info@suurmond.com

AUTOCLAVE

Voltweg 9
P.O. Box 307
8070 AH Nunspeet
The Netherlands

T +31 (0)341 - 262333
F +31 (0)341 - 262169

www.autoclave.nl
info@autoclave.nl



BELGIUM AND LUXEMBOURG:

SUURMOND BVBA

Noorderlaan 109
2030 Antwerp
Belgium

T +32 (0)3 - 5444070
F +32 (0)3 - 5444075

www.suurmond.be
info@suurmond.be

AUTOCLAVE

Noorderlaan 109
2030 Antwerp
Belgium

T +32 (0)3 - 5444077
F +32 (0)3 - 5444075

www.autoclave.be
info@autoclave.be



UNITED KINGDOM AND IRELAND:

SUURMOND UK Ltd

De Montfort House
7E Enterprise Way
P.O. Box 193
Evesham, Worcs
England
WR11 2WY

T +44 (0)1386 - 423756
F +44 (0)1386 - 423862

www.suurmond.co.uk
info@suurmond.co.uk

