

Valve Accessories

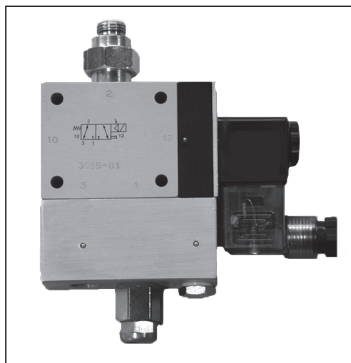

Electro-pneumatic Solenoid Valves

3/2 - ways:

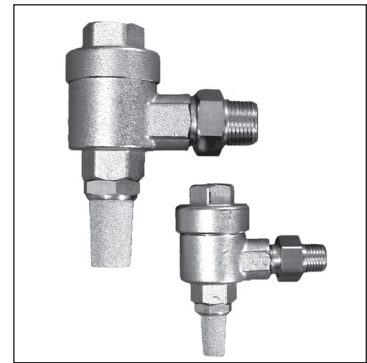
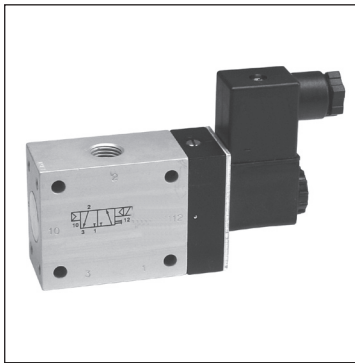
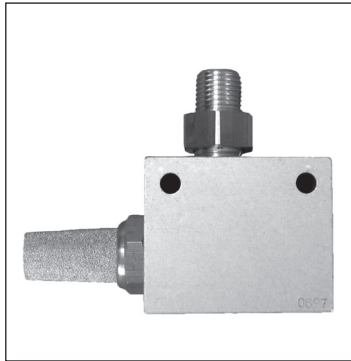
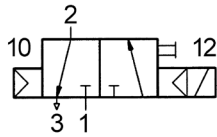

type M 073...
normally closed,
Pinch Valve open

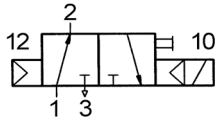

type MO 073...
normally open,
Pinch Valve closed

5/2 - ways:

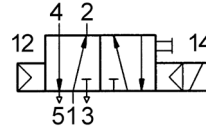

Typ / type M 075...

Design and function:

Spool valve with differential piston.
Actuated by a permanent electrical signal.

The design is the same as in case of 3/2-way valves, however it has 2 alternate switching outputs – one is currentless open and the other currentless closed.

Technical data 3/2+5/2- ways:

Connection:	G 1/4"	G 1/2"
Nominal size:	9 mm	14mm
Flow rate:	1580 NI/min	3330 NI/min
Pressure range:	1,5...10 bar	
Temperature:	-10 bis/to + 70°C	
Degree of prot.:	IP 65	



type: 3/2- Wege / ways



type: 5/2- Wege / ways

Non Return Flow Arrangement

Prevention of a back-flow of the pumping medium to the control line. If there is a defect in the pinch valve sleeve, the pumping medium can be pushed back into the control line, thus damaging the control units (solenoid valve etc.). The control line is blocked with the help of the RFS unit and the pumping medium is directly routed outwards. Thus, if there is a defect in the sleeve, only the back-flow preventer/ check valve will get dirty and damaged.

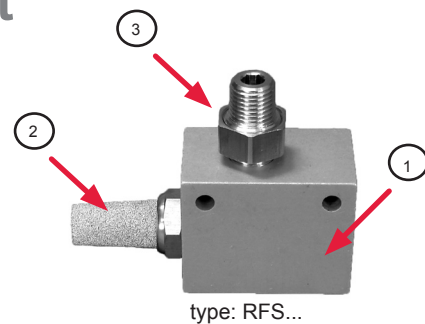

type: RFS...

Caution: Not suitable for hazardous mediums, since these could escape into the atmosphere/ environment.

Consisting of:

- ① 1x Flow-Return Valve
- ② 1x Sound Absorber
- ③ 1x Screw connection

Pressure Switch mechanical / digital

The pressure switch monitors the pressure of the pneumatic system as well as the control pressure and displays the switching status of the pinch valve. Besides, it can also be used to monitor any rupture in the sleeve, as in case of failure, normally the control pressure changes.

Technical data - Mechanical pressure switch:

Pressure adjustment:	0,5-8 bar
Threaded connection:	G 1/4" innen / internal
Ambient temperature:	- 20°C bis / to + 80°C
Features:	12-250V AC /12-125V DC
Protection:	IP 65



type 0880300

Technical data - Digital pressure switch:

Pressure adjustment:	0-16 bar
Threaded connection:	G 1/4" innen / internal
Ambient temperature:	- 10°C bis / to + 60°C
Power supply:	10 - 32 VDC
Protection in connection with cable socket M12:	IP 65



type: DS-33D

Pressure Regulator with Filter

The filter regulator includes a pressure controlling unit and a pneumatic filter with a condensate separator. The pressure setting is done with the handwheel.

Advantage: Longer service life of the sleeve due to optimum setting of the control-/ differential pressure.

Technical data:

Connection:	G 1/4"	G 1/2"
Inlet pressure:	max. 16 bar	max. 16 bar
Outlet pressure:	0,5 to 10 bar	0,5 to 10 bar
Nominal flow-rate:	1130 NI/min	3500 NI/min
Mounting position:	vertically, drain plug at bottom	



type: FRK...

Limit Switch Inductive

Limit switch inductive enables valve position indication (OPEN-CLOSE-position) of the armature.



type: IS38D

Pressure Relief Valves

The pneumatic pinch valve type V/VF/VM/VMF will be pressurized through the pressure relief section by a minimum of 2 bar over medium pressure. When the medium pressure in the valve line increases, the pinch valve opens and the overpressure passes the pinch valve. This will be controlled by using pressure switches.

Options: type LV:

if control air is available (incl. pressure gauge).

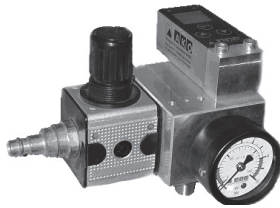

type: LV...

type LNV:

if control air is not available



type: LNV...
without pressure switch



type: LNVDD...
with digital pressure switch

The valve unit consists either of a pneumatic pinch valve plus relief section, or relief section to be used as a modification on existing pinch valves. Additional information upon request.

Light Plug with circuit protection

Accessory:

Visual recognition when solenoid valve is switched.



type: ST-06...

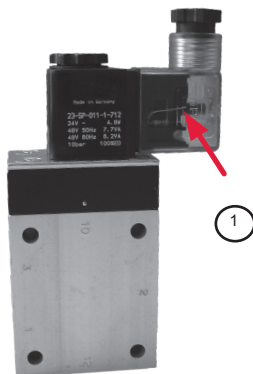

① Light plug with circuit protection

Airpump

Accessory:

For type LNV a handpump is available for an independent use from air compressor.



type: LP...

AKOVAC - Pinch Valve Vacuum Application Unit

When an AKO pinch valve is working in a vacuum line $>-0,1$ bar, the vacuum process will cause a reduction of the sleeve bore. This causes a lifetime reduction of the sleeve. The AKOVAC System prevents this and will keep the sleeve of the pinch valve fully open. The AKOVAC system can compensate max. vacuum line operation of $-0,8$ bar.



AKOVAC Basic

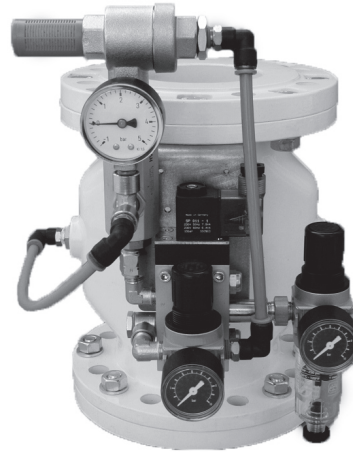

AKOVAC Comfort

The AKOVAC Comfort version allows a systematic adjustment of the pressures at the vacuum unit.

Safety Arrangement

In the event of loss of air pressure / power failure, an already closed pinch valve will remain in the closed position.

In the case of loss of air pressure, the pinch valve cannot be opened with the solenoid valve (electrically / mechanically).

In the case of a power failure, the pinch valve can be closed and opened via auxiliary manual operation of the solenoid valve.

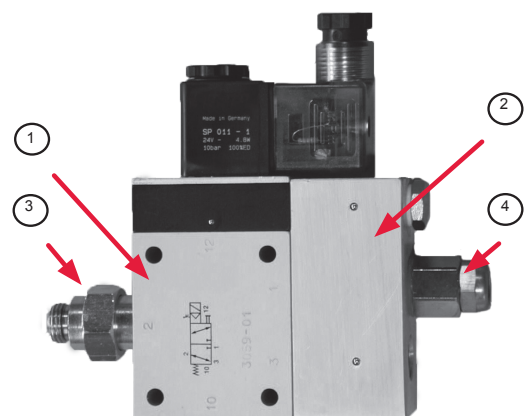

type: SS...

Consisting of:

- ① Solenoid Valve with light plug and circuit protection
- ② 1x Control block
- ③ 1x Screw connection, separable G 1/4" with o-ring
- ④ 1x Silencer, small parts

Visual Pressure Indicator Set

This unit is suited for monitoring and indicating operating conditions of AKO pinch valves. When the control pressure exceeds 1,5 bar to close the pinch valve, the visual pressure indicator will activate red.

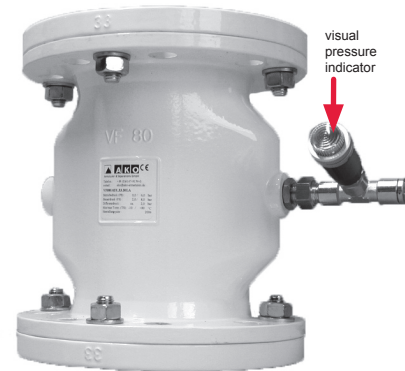

Quick Exhaust Valves (-Set)

Quick Exhaust Valves directly mounted to the pinch valves enable quicker opening time of the pinch valve. Also available with screw connection and sound absorber as SET.

Additional advantage: Less abrasion and higher lifetime of the pinch valve sleeve are possible.

Threaded connection: G 1/4", G 1/2"



type: SE-... (SET)

Assembling Accessories

Set 01

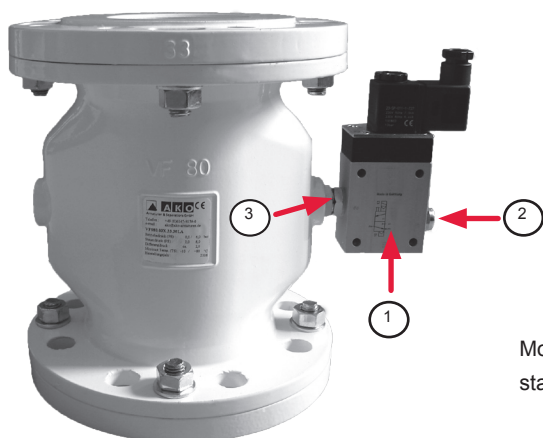

Mounting of basic accessories

i.e. Solenoid Valve with Sound Absorber, Fittings

- ① Solenoid Valve
- ② Sound Absorber
- ③ Fittings

Set 02

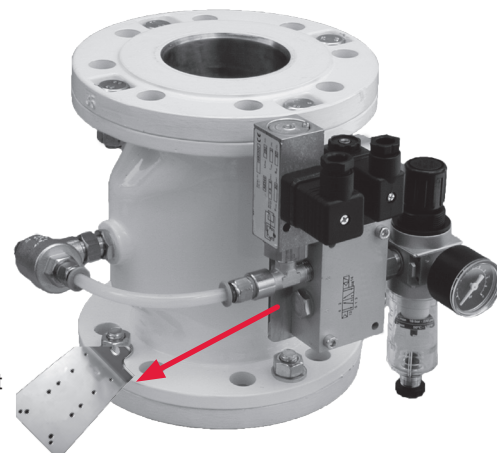

Mounting Bracket
stainless steel

Mounting several accessories

i.e. Solenoid, Sound Absorber, Pressure Switch, Pressure Regulator, Quick Exhaust Valve

Optional: Mounting Bracket stainless steel
→ for compact assembly of accessories.

Examples of Assembling Accessories

ASSEMBLING ACCESSORIES single and as SET

We prepare your valves as per your demand.

Knife Gate Valve:

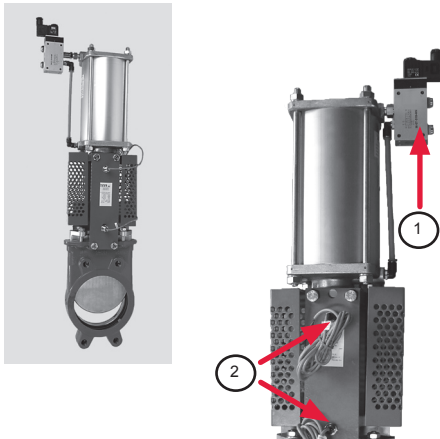

- ① Solenoid Valve
- ② Limit Switch

VZ-Valve:

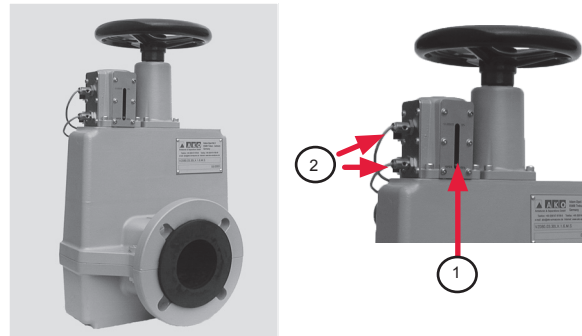

- ① Position Indicator
- ② Limit Switch

OV-Valve:

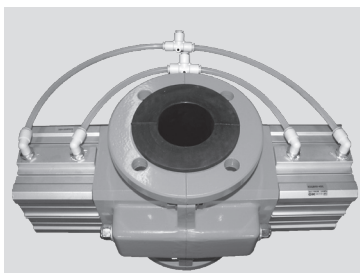

- ① filter regulator
- ② Limit Switch
- ③ Solenoid Valve

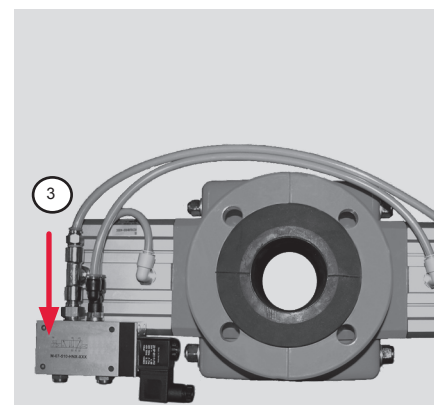
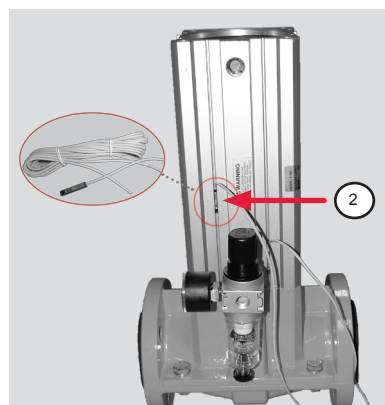
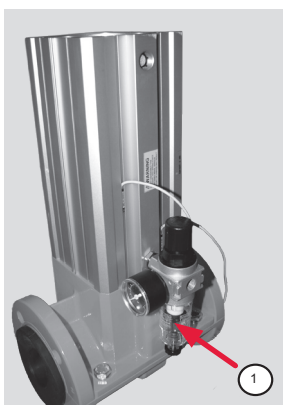

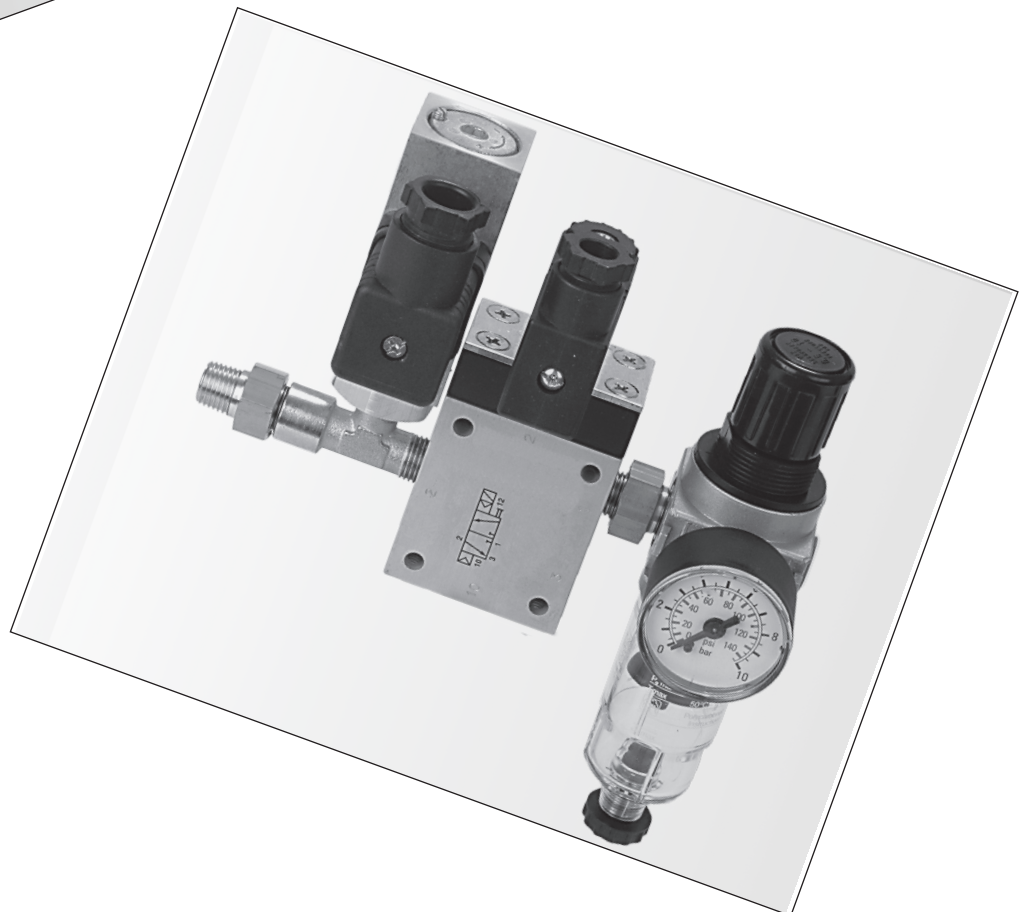

Technical details subject to change without notice.

AKO UK Ltd

12 Rutherford Way, Drayton Fields Industrial Estate, Daventry, Northamptonshire, NN11 8XW
Tel: 01327 312 747 • Fax: 01327 312 565 • E-mail: sales@ako-valves.com • Web: www.pinch-valves.com