

BIBUS Individual

Solutions for Systems and Assemblies



BIBUS[®]
■■■■ SUPPORTING YOUR SUCCESS

BIBUS general product range

From our comprehensive standard range, we offer you a large number of pneumatic, mechatronic and hydraulic components.

If you require a component which is not included in our standard range, we will endeavour to find a solution for your requirements.

BIBUS Individual is always the right partner for you.

Pneumatics



Valves and manifold valves



Valve clusters and plug-in valves



Filters, regulators and lubricators



Expanding shafts and rotary joints



Air-operated diaphragm pumps



Pressure and vacuum pumps

Mechatronics



Mass and shock absorbers



Gas springs and oil brakes



Linear and rotary systems

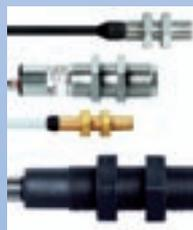

Switches and push-buttons



Sensors and switches



Motors, gears and brakes

Hydraulics



Filters



Pumps



Motors



Valves



Electronics



Accessories and spare parts

BIBUS Technology – Network of competencies

We are the link between the manufacturing plants and our customers. Our many years of trading partnerships are based on continuity and trust. In this way we achieve the best possible conditions for our customers.

Over 60 years of experience in the specialist areas of pneumatics, mechatronics, hydraulics and 3D technology have made BIBUS a leading provider in European industry.

BIBUS supporting your success

Range of services

Page 04-05



Pneumatics

Page 06-09



Mechatronics

Page 10-17

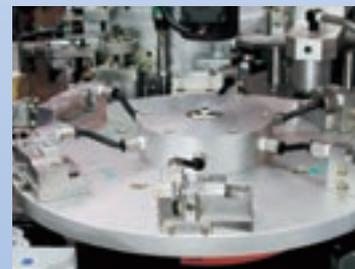

Hydraulics

Page 18-21



3D technology

Page 22





Development and installation of systems and assemblies

From a large number of components, we put one single delivery unit together for you. Whether you require a sub-assembly or a complete solution, we supply you with the module as you imagine it.

Irrespective of whether your requirement is in the area of pneumatics, mechatronics, hydraulics or 3D technology – we supply you with professional, individual solutions tailored to your needs.

With expert knowledge, innovation and high quality standards, we support you from design to implementation.



Quality and philosophy

Quality and the relevant qualifications go without saying at BIBUS.

Documented quality tests and functional tests guarantee a high degree of reliability.

BIBUS Technology specialises in the three core capabilities: engineering, logistics and services.

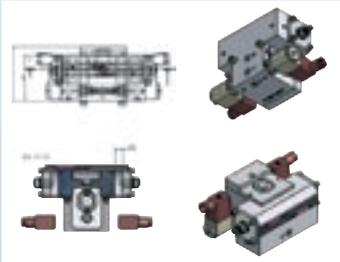

BIBUS engineering

BIBUS is your reliable partner for tailor-made solutions!

We provide ideas for implementation, develop detailed planning, calculate the cost and produce a prototype which we subject to comprehensive tests. We support you with advice and practical help from the sketch to implementation.

We carry out the necessary functional tests in special assembly and control rooms. Tested by us, with all design specifications and wiring diagrams and delivered with a functional warrantee, we shorten the distance for you between the concept and the machine and thus reduce your interfaces.



BIBUS logistics

Efficient logistics – our customers make the highest demands!

The procurement of assembly accessories and many small parts, production of the required delivery units, intermediate storage and logistics, BIBUS combines all these services for you. In this way you can concentrate on your core areas of expertise with our outsourcing solutions.

We guarantee a high degree of availability for our more than 250'000 standard articles. Modern warehouse systems with barcodes and mobile data logging terminals ensure an efficient flow of goods.

Our committed, experienced logistics specialists provide top-class services day in, day out.



BIBUS services

Our customers expect individual services!

We provide specific service and repairs in 18 European countries and guarantee a high degree of availability of spare parts throughout the product lifecycle!

- Commissioning and training.
- If necessary, we repair on site or in our workshops.
- Broad-based stockkeeping guarantees an efficient spare parts service.



Pneumatics

Assemblies, packaging services and special products in the main areas of activity:

- ***Pneumatic controls***
- ***Handling technology***
- ***Automation systems***
- ***Equipment engineering***
- ***Special cylinders***
- ***Special valves and valve manifolds***
- ***Add-on parts***

Examples of application- and customer-specific systems and assemblies



Bleeding unit for mobile hydraulic systems

This unit was specially developed for regenerating and bleeding mobile hydraulic systems.



Pressure tank

This assembly was produced based on the comprehensive specifications of the end-customer. Due to the intensive cooperation with the manufacturing plants and taking all necessary standards and workflows into account, commercial viability was achieved very quickly after tests with a prototype.

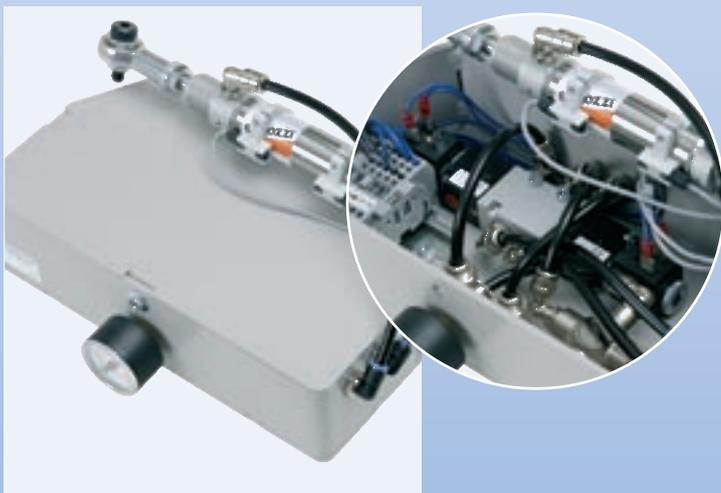

Flap control system

Pneumatic drive for textile machine. Designed for continuous operation and correspondingly high numbers of cycles.

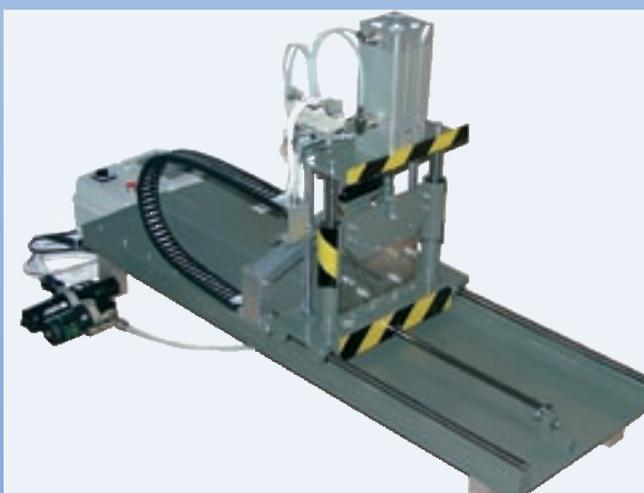

Cutter unit for cardboard profiles

This unit was developed for the automatic sectioning and cutting of cardboard profiles. During the cutting process, the knife moves with the profile to then return to its original position. The process is controlled by SPS and contains sensors and a measuring system.

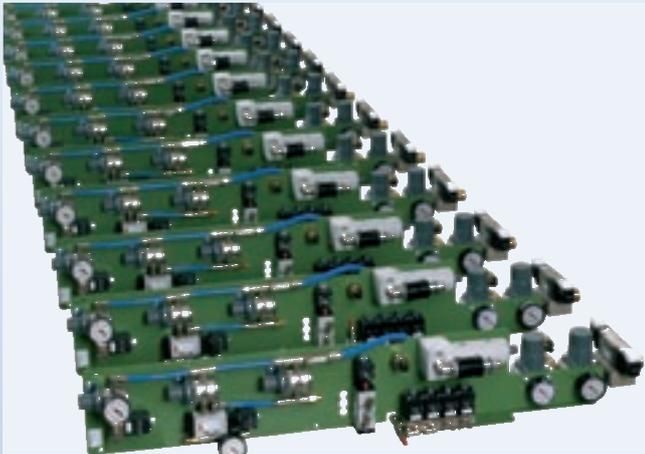

Pneumatic panel

Control panel for textile machines, completely wired to the electric interface and tested.



Handling for packaging machine

Electro-pneumatic automation system for the removal, transport and closing of bags in the food and animal feed industry.

Examples of tailor-made packaging services

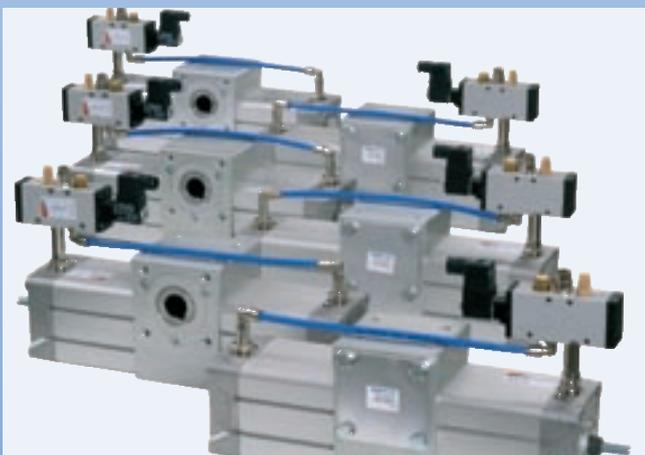

Rotating actuator system

Complete drive for a dosing slide in the food industry. In semi-automatic or fully automatic version for stepless positioning.

Examples of customised special products and manufactured parts

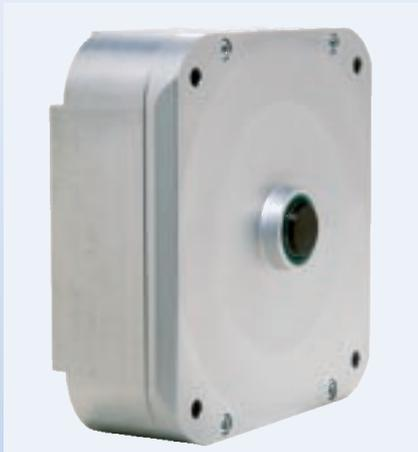

Compact cylinders

Compact cylinders for printing machines for very high actuation forces. Adapted to the restricted space conditions in the machine.

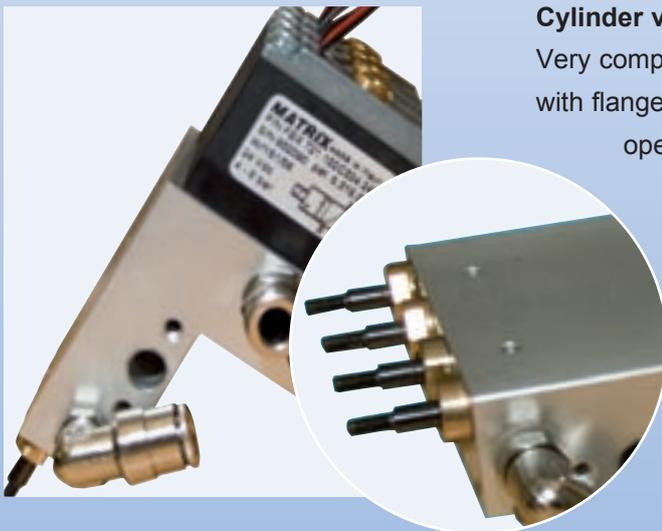

Cylinder valve unit

Very compact cylinder unit aligned to customer needs with flange-mounted high speed solenoid valves. For operation at the range of textile machines with extreme requisites in circuit time and product durability.



Winding cylinders

Special cylinders with hollow shaft for vacuum pipe for winding technology. High pressure forces, high requirements for precision.



Mechatronics

The area of mechatronics comprises the design and construction of modules and special designs in the area of:

- ***Drive technology***
- ***Damping technology***
- ***Linear and rotary technology***
- ***Switch technology***
- ***Safety engineering***

Examples of application- and customer-specific systems and assemblies

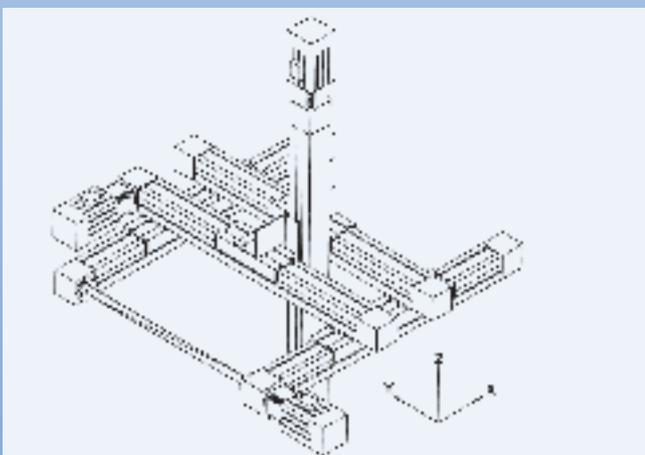

Mechanical multi-axis systems with toothed belt or ball screw

Linear axes in various designs and sizes, axis combinations in all development stages, complete solutions as linear or area gantry, including drive packages and peripherals for all areas of application of handling technology.



Rotation applications

NC rotary tables with cross roller bearings for extremely high loads and high-resolution direct drive systems in compact design for fast, precise positioning.



Cross table solution with rotary axis

Linear units with metal and/or bellows cover also in combination, for example as a coordinate table with ball screw drive. These drive elements can be combined with each other in any way and can be simply constructed as a multiple-axis system. This is the right solution especially where stability and precision are required.

Examples of tailor-made packaging services



Plug-in sensors and switches

Connection, cutting to length, insulating, crimping and labelling of cables and connection of the specific plug in accordance with the customer's requirements. The equipment is frequently pre-set and programmed by us.

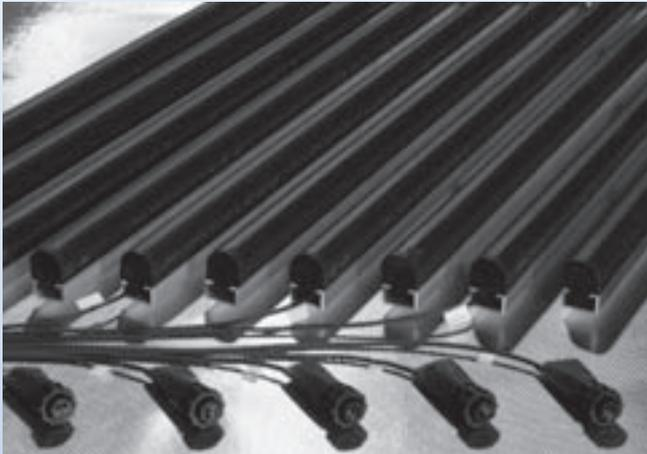

Packaged safety engineering

Safety components such as contact mats, bumpers or safety edges are tailored, equipped and packaged to the customer's requirements and mounted on suitable profiles.



Geared motor combinations

After calculation and design of the right drive package, the motor and gear are correctly assembled and tested. Other services are, for example, special lacquer coating, special drilling, lubrication for increased requirements, special shafts and assembly of customer-specific components and couplings.

Examples of customised special products and manufactured parts



Drives for lift tables

Electric lift columns for height adjustment of large loads with sturdy guide. Synchronous raising and lowering of loads via hydraulic linear drives. Various electric motors or a crank handle are used as drives.



Spindle assembly

From machining of the screw ends according to the production drawing to the installed and tested assembly. Design, production of parts and assembly from one source.



Special screws and nuts

Special solutions as a combination of tried and tested components and specially produced parts. Many installed parts can thus be obtained under one single article number.

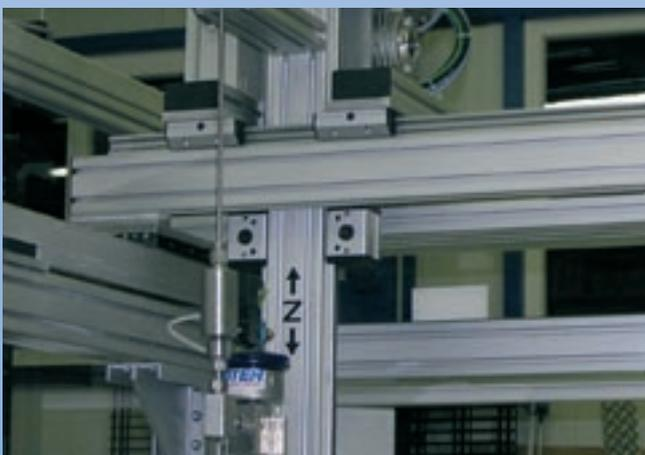

Linear units

Linear drive technology in humid environments on a special machining centre.



Palletising station

Palletising station for collecting, sorting and stacking geometrical objects on a pallet.



Handling system

Handling system for handling and transporting plastic panels from the extruder to the finishing machine.



Special machine

The complete solution shows a special machine made up of modular system components.



3-axis test rig

With the test rig, the long distance runner foot movement is simulated for quality control and monitored with sensors.



Aluminium machine frames

Machine frames in heavy-duty aluminium construction for an automatic machining centre in the automobile industry.

Workstation design

The products of our system construction kit are cost-effective, flexible and versatile, for example for individual workstation systems and workstation design.



Worktables

Individual worktables made of combinable modular aluminium profiles.

Protective and dividing wall

Our modular components can be used universally for protective and dividing walls in all areas of machine construction, industrial automation or for works equipment.



Protective machine housing

Transparent protective housing for full view of production process.



Transparent protective housing

Retrofittable safety equipment for existing machine.

Material flow

The material flow sector shows examples of transport equipment and conveyor belts.



Inclining transport

Height adjustable workpiece conveyor belt for the automotive supplier industry.



Roller track

Roller track for supply to the assembly station.

Dynamics

The dynamic elements group contains components which enable precise linear and rotary movements.



Linear units LG

Heavy duty linear units
(carriage load up to 12,000 N).

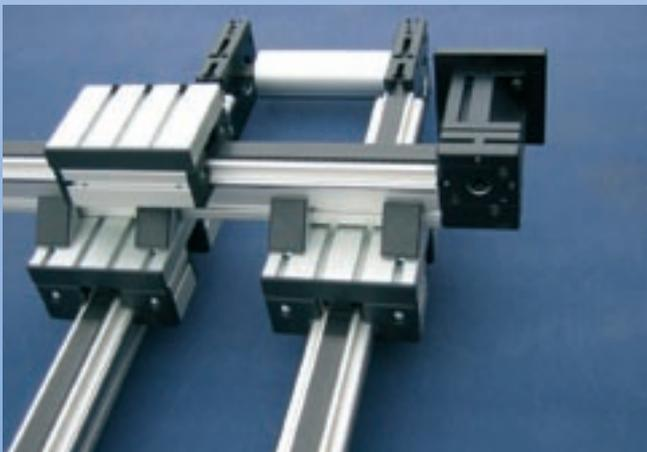

Cross table

Two-axis system for positioning tools
in assembly technology.



Hydraulics

Main areas of application:

- **Assemblies and powerpack engineering**
- **Hydrostatic drives**
- **Hydraulic controls and regulations**
- **System solutions**

Examples of customised design for industrial applications



Compact unit

Specially developed and designed to the customer requirements taking into consideration the very strict assembly and functional specifications. A special design for the plastic machinery industry.



Powerpack

Customer-specific design combining hydraulic and pneumatic systems in one unit. Application specifically for the machine tool industry, where the strict regulations of the automobile industry had to be complied with.

Examples of tailor-made system solutions in the area of mobile hydraulics



Airport snowblower

Both the drive and the blower drive are hydrostatic. The total output of 1260 kW enables a working speed of 55 km/h. The complete concept and design/projecting were developed in close cooperation with the customer.



Railway maintenance vehicle

Railway maintenance tractor with hydrostatic drive, specifically designed for the Swiss tectonic conditions. System responsibility for the complete hydrostatic drive lives with BIBUS. The SBB (Swiss National Railway) has more than 100 of such vehicles in its fleet.



Industrial hydraulics for forestry tractors

Specific retrofits on existing equipment require a high degree of adaptability. The selection of the components and incorporation in an existing system are only possible in a partnership with the machine manufacturer based on trust.



Large surface mower

A tried and tested customer development in which the interaction of hydrostatics and work hydraulics has made the design a success. Support was fully effective, from the concept and design to assembly and commissioning.



Wheeled loaders

Leading the way in a new generation of hydrostatic drives, the BIBUS ICVD variable displacement motor is used in this vehicle. The availability of tractive power over the whole speed range, 0-40 km/h, and considerably improved efficiency have induced our partners to convert the whole product range to the new drive within a very short time.

Examples of applications using compact hydraulic systems



Single axis mower

The advantage of high power density of hydraulic drives is not exclusively reserved for large machines. The compact units are ideally suited to driving light vehicles for professional lawn care even with low drive outputs.



Compact hydraulics

The pumps and motor range of compact hydraulics, combined to form half-axes and complete axes, produce a simple, autonomous drive.

Examples of special products, own developments, customer-specific assemblies

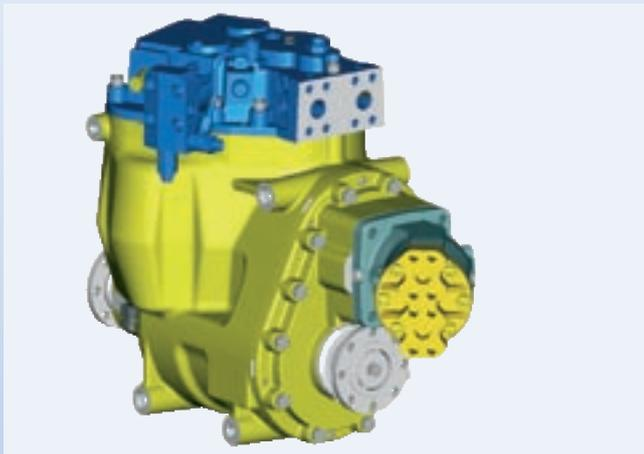

Integrated continuously variable drive

BIBUS ICVD variable displacement motor with wide angle technology.

A joint development by BIBUS and GKN Walterscheid.



Assemblies

Assemblies ready to install are delivered on time to the customer facilities, so that only installation in the machines and connecting have to be carried out by the customer.



Rotor pump

Compact open circuit axial piston variable displacement pump, integrated in an electric motor. The special feature consists in our further development to an electrically proportional displacement control with angle monitoring, produced for the specific needs of the plastics industry. The closed control circuit is capable of achieving the required high reaction times.

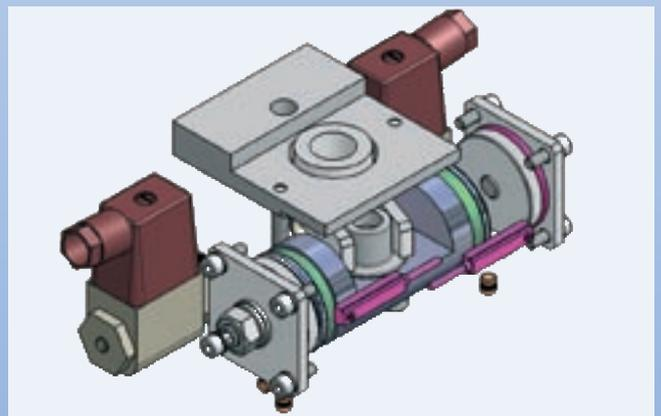

Development of add-on parts

Own development of electro-hydraulic displacement control as an add-on to an exclusively mechanically displaced compact axial piston pump for a closed hydraulic circuit. A customer-specific development for equipment in the lawn care sector.

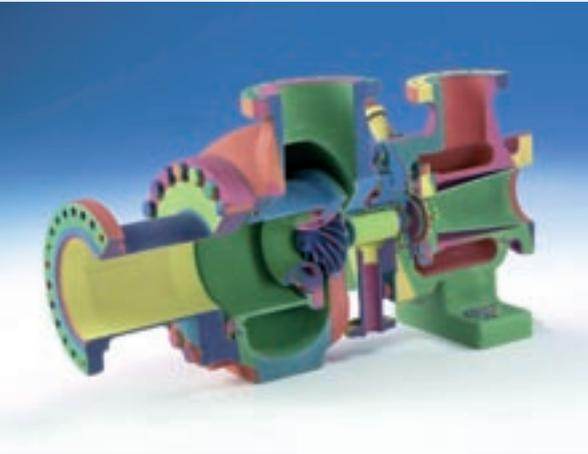

3D models enable better visualisation

A 3D printer produces concept models and functional components from digital data simply, quickly and at low cost. The versatility of the printers enables quick production of parts for analysis and testing in the design phase up to functional testing of the components or prototypes. Even model moulds for casting applications can be produced.

3D Printer

Jetting-Technology – the fastest on the market

Lowest operating costs, very affordable.

Using an inkjet print-head to deposit a liquid binder that solidifies layers of powder concept models and functional parts are created with full 24bit colour.

Polyjet-Technology – for plastic parts

Photopolymer materials are jetted in ultra-thin layers (16 μ) onto a build tray layer by layer. Each photopolymer layer is cured by UV light immediately after it is jetted. Accurate and highly detailed parts and models.



3D Scanner

Completing the Rapid Prototyping product range 3D Scanner are used for reverse engineering or for non-contact measuring.

Depending on the application BIBUS offers top-technology with laser-triangulation or the unique 3D hand-held scanner, self-orientating without using a tripod.



3D Software

Our Rapid Prototyping software includes the check of the CAD data prior 3D printing as well. The software reduces the effort for correction of the 3D file and provides many other features to edit the files easily.

BIBUS locations - network of competencies

Headquarters and Switzerland

BIBUS AG

Allmendstrasse 26
CH-8320 Fehraltorf
Tel. +41 44 877 50 11
Fax +41 44 877 50 19
E-mail: info.bag@bibus.ch
www.bibus.ch

BIBUS HYDRAULIK AG

Allmendstrasse 26
CH-8320 Fehraltorf
Tel. +41 44 877 52 11
Fax +41 44 877 52 19
E-mail: info.bhag@bibus.ch
www.bhag.bibus.ch

Austria

BIBUS Austria GmbH

Eduard Klinger-Strasse 12
AT-3423 St. Andrä-Wördern
Tel. +43 2242 33 388
Fax +43 2242 33 388 10
E-mail: info@bibus.at
www.bibus.at

Belarus

BIBUS (BY) COOO

8th Per. Ilyicha 13a, office 2.1
BY-246013 Gomel
Tel. +375 232 37 10 01
Fax +375 232 37 10 01
E-mail: info@bibus.by
www.bibus.by

Bulgaria

BIBUS Bulgaria Ltd.

Lulin Plaza, Office 3A
5 Dobri Nemirov Str.
BG-1324 Sofia
Tel. +359 885 494 275
Fax +359 292 732 64
E-mail: info@bibus.bg
www.bibus.bg

Croatia

BIBUS Zagreb d.o.o.

Anina 91
HR-10000 Zagreb
Tel. +385 1 381 80 04
Fax +385 1 381 80 05
E-mail: bibus@bibus.hr
www.bibus.hr

Czech Republic

BIBUS s.r.o.

Videnska 125
CZ-639 27 Brno
Tel. +420 5 47 125 300
Fax +420 5 47 125 310
E-mail: bibus@bibus.cz
www.bibus.cz

Denmark

A/S H. SINDBY & Co

Bommerhavevej 41, Sjelde
DK-7100 Vejle
Tel. +45 75 88 21 22
Fax +45 75 88 22 40
E-mail: sindby@sindby.dk
www.sindby.dk

France

BIBUS France S.A.S.

ZI du Chapotin
85, Avenue Marius Berliet
FR-69970 Chaponnay
Tel. +33 4 7896 80 00
Fax +33 4 7896 80 01
E-mail: contact@bibusfrance.fr
www.bibusfrance.fr

Germany

BIBUS GmbH

Lise-Meitner-Ring 13
DE-89231 Neu-Ulm
Tel. +49 731 20 76 90
Fax +49 731 20 76 96 20
E-mail: info@bibus.de
www.bibus.de

Great Britain

BIBUS (UK) Ltd

20 Soho Mills
GB-Wooburn Green HP10 0PF
Tel. +44 1628 533 300
Fax +44 1628 533 377
E-mail: info@bibus.co.uk
www.bibus.co.uk

Hungary

BIBUS Kft

Ujhegyi ut 2
HU-1103 Budapest
Tel. +36 1 265 27 33
Fax +36 1 264 89 00
E-mail: info@bibus.hu
www.bibus.hu

Poland

BIBUS MENOS Sp. z o.o.

ul. Tadeusza Wendy 7/9
PL-81-341 Gdynia
Tel. +48 58 660 95 70
Fax +48 58 661 71 32
E-mail: info@bibusmenos.pl
www.bibusmenos.pl

Romania

BIBUS SES SRL

Pestalozzi Street 22
RO-300155 Timisoara
Tel. +40 256 200 500
Fax +40 256 220 666
E-mail: office@bibus.ro
www.bibus.ro

Russia

BIBUS o.o.o.

Izmailovsky prospect 2A
RU-190005 St. Petersburg
Tel. +7 812 251 62 71
Fax +7 812 251 90 14
E-mail: info@bibus.ru
www.bibus.ru

Slovakia

BIBUS SK s.r.o.

Priemysel'na' 4
SK-949 01 Nitra
Tel. +421 37 741 25 25
Fax +421 37 651 67 01
E-mail: sale@bibus.sk
www.bibus.sk

Slovenia

INOTEH d.o.o.

K Železnici 7
SI-2345 Bistrica ob Dravi
Tel. +386 2 665 11 31
Fax +386 2 665 20 81
E-mail: info@inoteh.si
www.inoteh.si

Ukraina

BIBUS Ukraine TOV

Ul. Mashinobudivnykiv 5a
UA-08162 Chabany, Kyiv region
Tel. +380 44 545 44 04
Fax +380 44 545 54 83
E-mail: info@bibus.com.ua
www.bibus.com.ua



-  **BIBUS AG**
-  Other **BIBUS** locations

BIBUS Individual 05-2008 / 3000 EN