

Hafner (UK)
Unit 4 Forest Row Business Park,
Station Road
Forest Row, East Sussex. RH18 5DW

Phone +44 (0) 13 42 82 64 88
Fax +44 (0) 13 42 82 64 89

info@hafner-pneumatic.co.uk
www.hafner-pneumatic.co.uk

Hafner-Pneumatik Krämer KG
Stammheimer Straße 10
D-70806 Kornwestheim

Phone +49 - 71 54 - 82 72 60
Fax +49 - 71 54 - 82 72 68

info@hafner-pneumatik.de
www.hafner-pneumatik.de

A Division of Air Engineering Controls Ltd.

Air Preparation Equipment

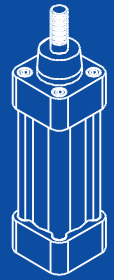
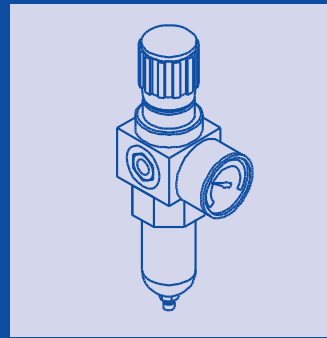
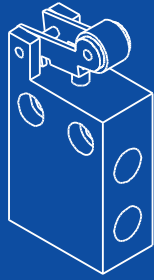

2008

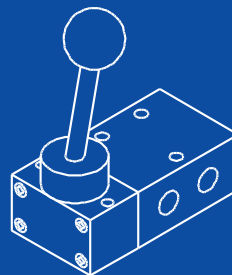
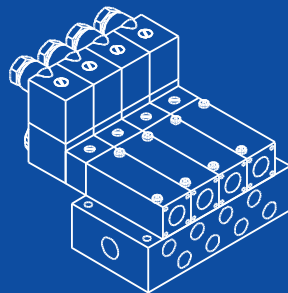
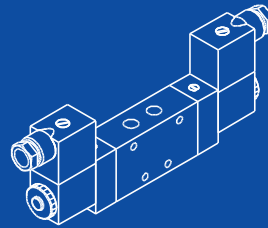
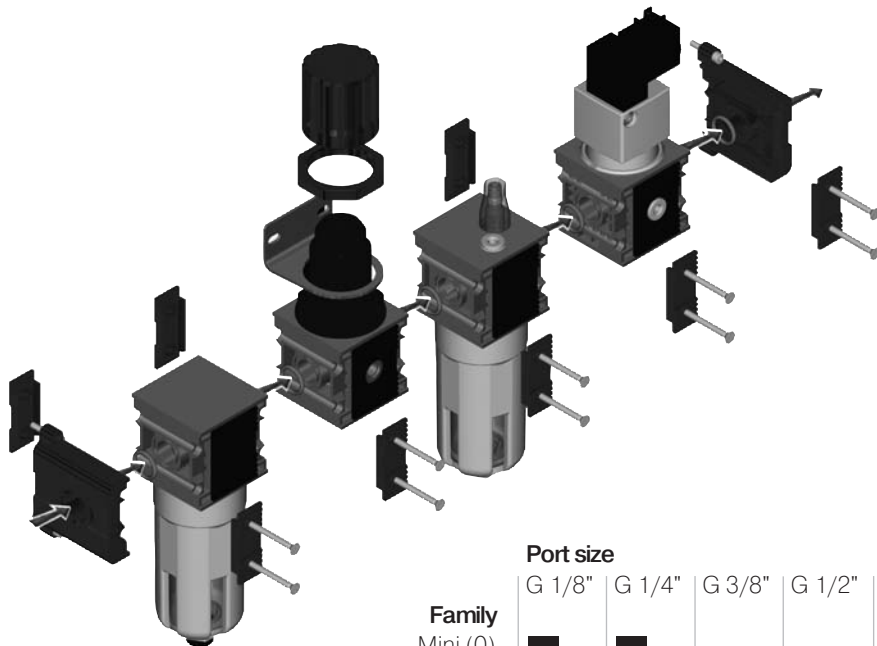

Table of Contents

page		Air Preparation Equipment
2	3.1	Introduction
3	3.2	Mini Filter Regulator and Lubricator sets
4	3.3	Mini Filter Regulators
5	3.4	Mini Regulators
6	3.5	Mini Filters
7	3.6	Mini Lubricators
8	3.7	Filter Regulator and Lubricator sets
9	3.8	Filter Regulators
10	3.9	Regulators
11	3.10	Filters
12	3.11	Lubricators
13	3.12	3/2-way Shut-Off Valves
14	3.13	Soft Start Valves
15	3.14	Accessories

Introduction

The new range of air line equipment consists of four families covering the port-sizes from G1/8" to G1". The highly flexible modular system allows different combinations of units to be built adding appropriately threaded end plates for the required port size.



Family	Port size					
	G 1/8"	G 1/4"	G 3/8"	G 1/2"	G 3/4"	G 1"
Mini (0)	■	■				
1	■	■	■			
2		■	■	■		
3					■	■

■ standard product
 ■ available on request

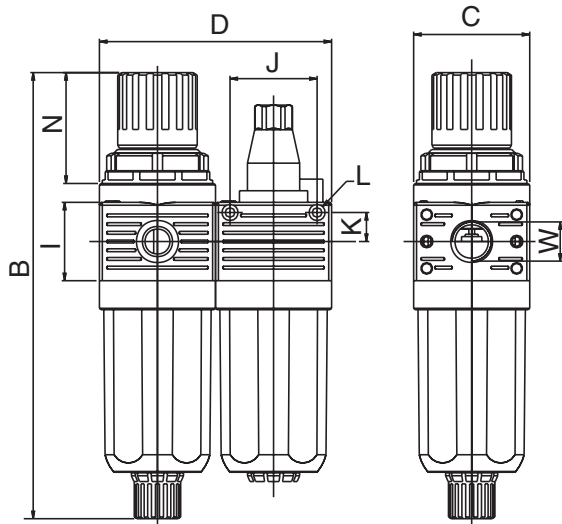
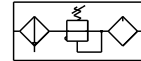

Main features

Filter regulator:

Rolling membrane regulation valve with secondary air bleed, admission pressure compensation, without intrinsic consumption, with detend-stop adjusting knob, condensate collector with filter cartridge, filter element 20 μm – others on request, please refer to page 3.14 – semi-automatic condensate discharge.

Lubricator:

Direct-proportional lubricator, recommended types of oil: Mineral oils of viscosity class VG 22 a (ISO 3448).

Recommended consumption: 1-2 drops / m^3 air.

Technical information

Operating pressure in p1:	Max. 15 bar at 20° C
Operating pressure out p2:	0 bar ... 12 bar, others on request
Operating medium:	Compressed air
Operating temperature:	-10° C ... +50° C
Installation positioning:	Vertical
Materials:	Body and Shell: Technopolymer
	Gaskets: NBR
	Filter: Sintered bronze
	End parts: Die-cast zinc

Pressure gauge (included in delivery):	
Accuracy class:	1,6
Diameter:	40 mm
Connecting thread:	G 1/8"
Indicator range:	0 ... 12 bar

FRL-0

A	
B	156
C	40
D	80
J	30
K	9,25
L	D X M3
W	1/8"-1/4"

Family	Port Size	Flow Rate qnN*	Bowl Capacity	Part Number
Mini (0)	G 1/8"	260 l/min	17,5 cm^3	FRL-0-1/8
Mini (0)	G 1/4"	260 l/min	17,5 cm^3	FRL-0-1/4

* Measured at p1=10 bar, p2=6 bar, $\Delta p=1$ bar according to CETOP RP 50P

Mini Filter Regulator



Main Features

Rolling membrane regulation valve with secondary air bleed, admission pressure compensation, without intrinsic consumption, with detent-stop adjusting knob, condensate collector with filter cartridge, filter element 20 μm – others on request, please refer to page 3.14 – semi-automatic discharge.

Technical information

Operating pressure in p1:	Max. 15 bar at 20° C
Operating pressure out p2:	0 bar ... 12 bar, others on request
Operating medium:	Compressed air
Operating temperature:	-10° C ... + 50° C
Installation positioning:	Vertical
Materials:	Body and Shell: Technopolymer
	Gaskets: NBR
	Filter: Sintered bronze
	End parts: Die-cast zinc

Pressure gauge (included in delivery):	
Accuracy class:	1,6
Diameter:	40 mm
Connecting thread:	G 1/8 "
Indicator range:	0 ... 12 bar

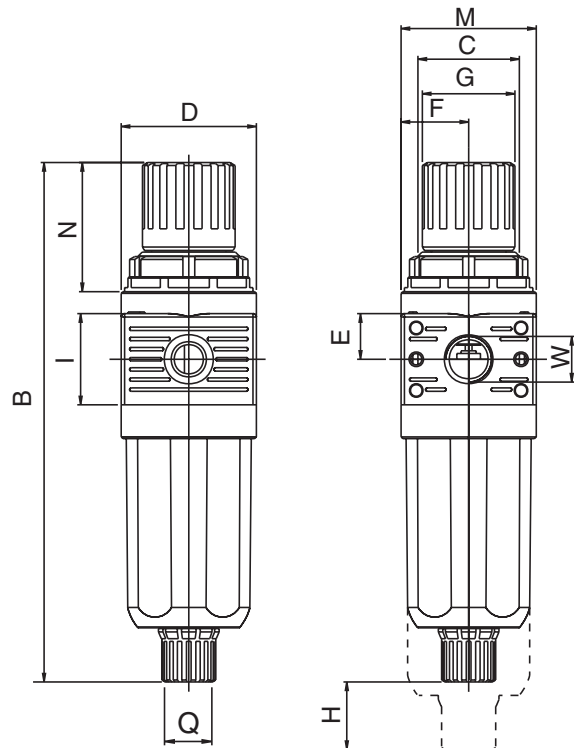

FR-0	
A	
B	156
C	40
D	40
E	13,5
F	20
G	27,5
H	11
I	27
J	
K	
L	D X M3
M	
N	40
W	1/8"-1/4"

Family	Port Size	Flow Rate qnN*	Bowl Capacity	Part Number
Mini (0)	G 1/8"	600 l/min	17,5 cm ³	FR-0-1/8
Mini (0)	G 1/4"	600 l/min	17,5 cm ³	FR-0-1/4

* Measured at p1=10 bar, p2=6 bar, Δp=1 bar according to CETOP RP 50P

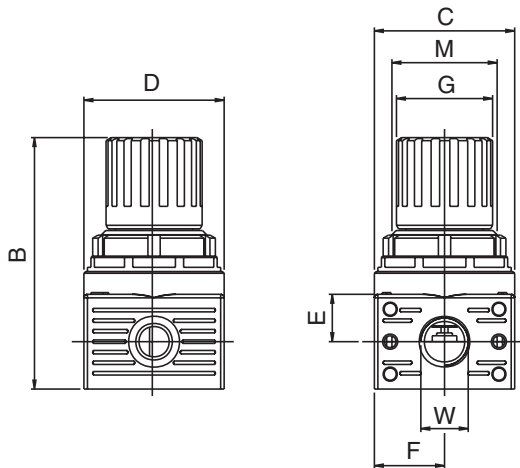

Main features

Rolling membrane regulation valve with secondary air bleed, admission pressure compensation, without intrinsic consumption, with detend-stop adjusting knob.

Technical information

Operating pressure in p1:	Max. 15 bar at 20° C
Operating pressure out p2:	0 bar ... 12 bar, others on request
Operating medium:	Compressed air
Operating temperature:	-10° C ... + 50° C
Installation positioning:	Vertical
Materials:	Body: Technopolymer
	Gaskets: NBR
	Filter: Sintered bronze
	End parts: Die-cast zinc

Pressure gauge (included in delivery):	
Accuracy class:	1,6
Diameter:	40 mm
Connecting thread:	G 1/8 "
Indicator range:	0 ... 12 bar

R-0	
A	
B	74
C	40
D	40
E	13,5
G	27,5
I	27
J	
K	
L	
M	
W	1/8"-1/4"

Family	Port Size	Flow Rate qnN*	Part Number
Mini (0)	G 1/8"	600 l/min	R-0-1/8
Mini (0)	G 1/4"	600 l/min	R-0-1/4

* Measured at p1=10 bar, p2=6 bar, Δp=1 bar according to CETOP RP 50P

Mini Filters



Main features

Centrifugal collector with sinter filter cartridge, filter element 20 µm – others on request, please refer to page 3.14 – semi-automatic condensate discharge.

Technical information

Operating pressure in p1:	Max. 15 bar at 20° C
Operating medium:	Compressed air
Operating temperature:	-10° C ... + 50° C
Installation positioning:	Vertical
Materials:	Body and Shell: Technopolymer
	Gaskets: NBR
	Filter: Sintered bronze
	End parts: Die-cast zinc

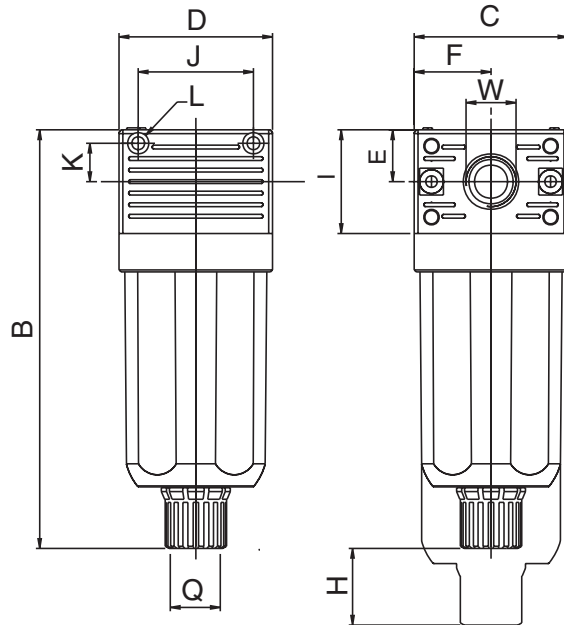

F-0	
A	
B	109
C	40
D	40
E	13,5
F	20
H	11
I	27
J	30
K	9,25
L	D X M3
W	1/8"-1/4"

Family	Port Size	Flow Rate qnN*	Bowl Capacity	Part Number
Mini (0)	G 1/8"	1200 l/min	17,5 cm ³	F-0-1/8
Mini (0)	G 1/4"	1200 l/min	17,5 cm ³	F-0-1/4

* Measured at p1=10 bar, p2=6 bar, Δp=1 bar according to CETOP RP 50P

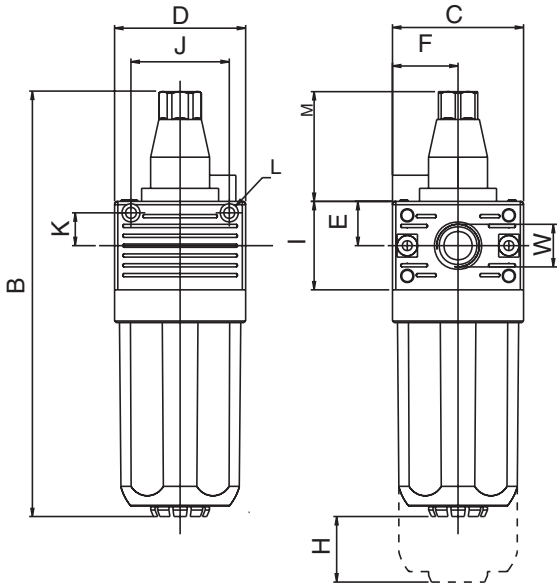

Main features

Direct-proportional lubricator, recommended types of oil: Mineral oils of viscosity class VG 22 a (ISO 3448).

Recommended consumption: 1-2 drops / m³ air.

Technical information

Operating pressure in p1:	Max. 15 bar at 20° C
Operating medium:	Compressed air
Operating temperature:	-10° C ... + 50° C
Installation positioning:	Vertical
Materials:	Body and Shell: Technopolymer Gaskets: Perbunan End parts: Die-casted zinc

L-0

A	
B	130
C	40
D	40
E	13,5
H	11
I	27
J	30
K	9,25
L	DX M3
M	33,5
W	1/8"-1/4"

Family	Port Size	Flow Rate qnN*	Bowl Capacity	Part Number
Mini (0)	G 1/8"	720 l/min	17,5 cm ³	L-0-1/8
Mini (0)	G 1/4"	720 l/min	17,5 cm ³	L-0-1/4

* Measured at p1=10 bar, p2=6 bar, Δp=1 bar according to CETOP RP 50P

Filter Regulator and Lubricator sets

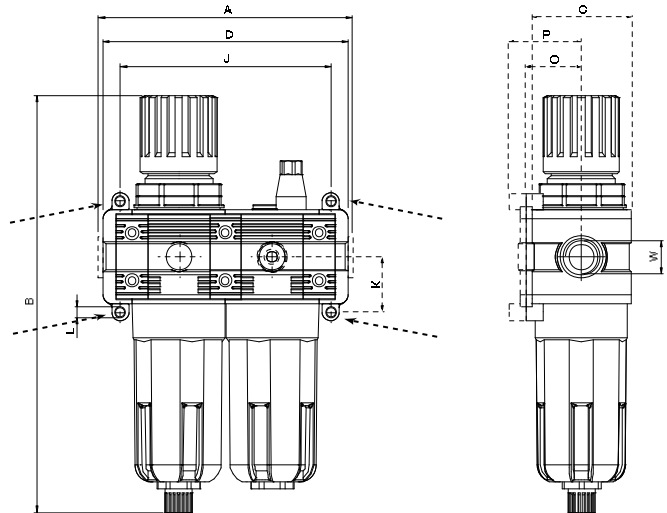
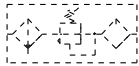

Main features

Filter regulator

Rolling membrane regulation valve with secondary air bleed, admission pressure compensation, without intrinsic consumption, with detend-stop adjusting knob, condensate collector with filter cartridge, filter element 20 µm – others on request, please refer to page 3.14 – semi-automatic condensate discharge.

Lubricator

Direct-proportional lubricator, recommended types of oil: Mineral oils of viscosity class VG 22 a (ISO 3448).
Recommended consumption: 1-2 drops / m³ air.

Technical information

Operating pressure in p1: Max. 15 bar at 20° C
 Operating pressure out p2: 0 bar ... 12 bar, others on request
 Operating medium: Compressed air
 Operating temperature: -10° C ... + 50° C
 Installation positioning: Vertical
 Materials: Body and Shell: Technopolymer
 Gaskets: NBR
 Filter: Sintered bronze
 End parts: Die-cast zinc

Pressure gauge (included in delivery):
 Accuracy class: 1,6
 Diameter: 40 mm
 Connecting thread: G 1/8 "
 Indicator range: 0 ... 12 bar

	FRL 1	FRL 2	FRL 3
A	129	159	180
B	198	244,5	273
C	45	59	70
D	119	144	171*
J	124,5	152	174
K	17,25	22	27
L	D X M4	D X M5	D X M6
W	(1/8")-1/4"-3/8"	(1/4")-3/8"-1/2"	1/2"-3/4"-1"

*) Variante G1" plus 5 mm

Family	Port Size	Flow Rate qnN*	Bowl Capacity	Drain	Part Number
1	G 1/4 "	1100 l/min	22 cm ³	Semi-auto	FRL-1-1/4
1	G 3/8"	1100 l/min	22 cm ³	Semi-auto	FRL-1-3/8
2	G 3/8"	2500 l/min	46 cm ³	Semi-auto	FRL-2-3/8
2	G 1/2"	2500 l/min	46 cm ³	Semi-auto	FRL-2-1/2
2	G 1/2"	2500 l/min	46 cm ³	Auto	FRL-2-1/2-A
3	G 3/4"	4300 l/min	89,5 cm ³	Semi-auto	FRL-3-3/4
3	G 3/4"	4300 l/min	89,5 cm ³	Auto	FRL-3-3/4-A
3	G 1"	4300 l/min	89,5 cm ³	Semi-auto	FRL-3-1
3	G 1"	4300 l/min	89,5 cm ³	Auto	FRL-3-1-A

* Measured at p1=10 bar, p2=6 bar, Δp=1 bar according to CETOP RP 50P

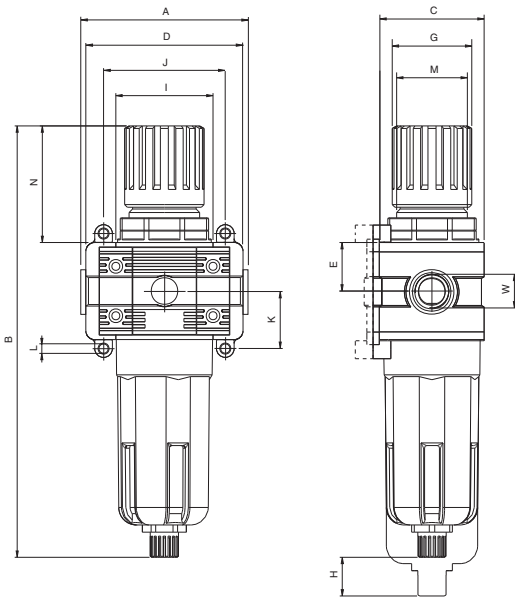

Technical information

Operating pressure in p1: Max. 15 bar at 20° C
 Operating pressure out p2: 0 bar ... 12 bar, others on request
 Operating medium: Compressed air
 Operating temperature: -10° C ... + 50° C
 Installation positioning: Vertical
 Materials: Body and Shell: Technopolymer
 Gaskets: NBR
 Filter: Sintered bronze
 End parts: Die-cast zinc

Pressure gauge (included in delivery):
 Accuracy class: 1,6
 Diameter: 40 mm
 Connecting thread: G 1/8"
 Indicator range: 0 ... 12 bar

Main features

Rolling membrane regulation valve with secondary air bleed, admission pressure compensation, without intrinsic consumption, with detent-stop adjusting knob, condensate collector with filter cartridge, filter element 20 µm – others on request, please refer to page 3.14 – semi-automatic discharge.

	FR-1	FR-2	FR-3
A	86	104	115
B	198	244,5	273
C	45	59	70
D	76	89	106
E	21	27.5	32,5
F	22,5	28.5	35
G	36	45	50,5
H	39	48	50
I	43	55	65
J	81,5	97	109
K	17.25	22	27
L	D X M4	D X M5	D X M6
M	M32 x 1,5	M40 x 1,5	M47 x 1,5
N	52	66	75.5
W	(1/8")-1/4"-3/8"	(1/4")-3/8"-1/2"	1/2"-3/4"-1"

*) Variante G1" plus 5 mm

Family	Port Size	Flow Rate qnN*	Bowl Capacity	Drain	Part Number
1	G 1/4 "	1650 l/min	22 cm ³	Semi-auto	FR-1-1/4
1	G 3/8"	1650 l/min	22 cm ³	Semi-auto	FR-1-3/8
2	G 3/8"	3000 l/min	46 cm ³	Semi-auto	FR-2-3/8
2	G 1/2"	3000 l/min	46 cm ³	Semi-auto	FR-2-1/2
2	G 1/2"	3000 l/min	46 cm ³	Auto	FR-2-1/2-A
3	G 3/4"	4500 l/min	89,5 cm ³	Semi-auto	FR-3-3/4
3	G 3/4"	4500 l/min	89,5 cm ³	Auto	FR-3-3/4-A
3	G 1"	4500 l/min	89,5 cm ³	Semi-auto	FR-3-1
3	G 1"	4500 l/min	89,5 cm ³	Auto	FR-3-1-A

Regulators

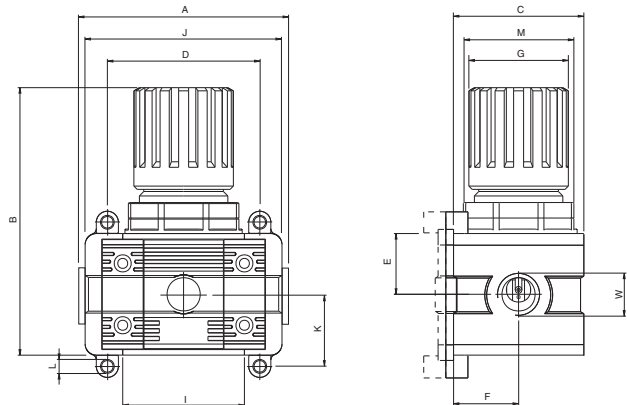

Main features

Rolling membrane regulation valve with secondary air bleed, admission pressure compensation, without intrinsic consumption, with detend-stop adjusting knob.

Technical information

Operating pressure in p1:	Max. 15 bar at 20° C	
Operating pressure out p2:	0 bar ... 12 bar, others on request	
Operating medium:	Compressed air	
Operating temperature:	-10° C ... + 50° C	
Installation positioning:	Vertical	
Materials:	Body:	Technopolymer
	Gaskets:	NBR
	Filter:	Sintered bronze
	End parts:	Die-cast zinc

Pressure gauge (included in delivery):	
Accuracy class:	1,6
Diameter:	40 mm
Connecting thread:	G 1/8"
Indicator range:	0 ... 12 bar

	R-1	R-2	R-3
A	72	89	100
B	97	121	140,5
C	45	59	70
D	76	89	106*
E	21	27,5	32,5
G	36	45	50,5
I	43	55	65
J	54	69	79
K	17,25	22	27
L	D X M4	D X M5	D X M6
M	M32 x 1,5	M40 x 1,5	M47 x 1,5
W	(1/8")-1/4"-3/8"	(1/4")-3/8"-1/2"	1/2"-3/4"-1"

*) Variante G1" plus 5 mm

Family	Port Size	Flow Rate qnN*	Part Number
1	G 1/4 "	2050 l/min	R-1-1/4
1	G 3/8"	2050 l/min	R-1-3/8
2	G 3/8"	3200 l/min	R-2-3/8
2	G 1/2"	3200 l/min	R-2-1/2
3	G 3/4"	6200 l/min	R-3-3/4
3	G 1"	6200 l/min	R-3-1

* Measured at p1=10 bar, p2=6 bar, Δp=1 bar according to CETOP RP 50P

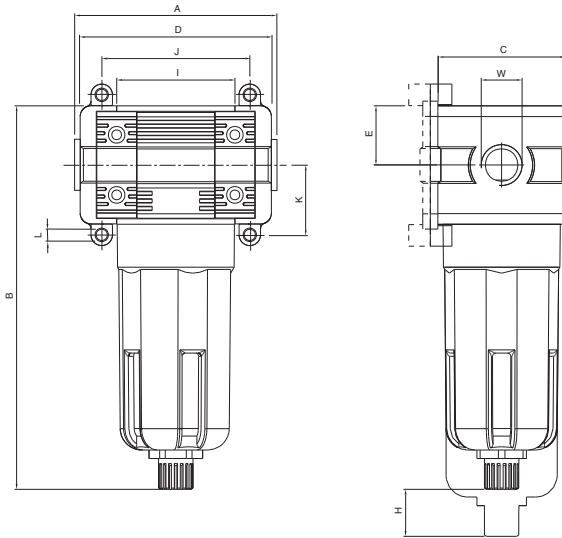

Main features

Centrifugal collector with sinter filter cartridge, filter element 20 µm – others on request, please refer to page 3.14 – semi-automatic condensate discharge.

Technical information

Operating pressure in p1:	Max. 15 bar at 20° C
Operating medium:	Compressed air
Operating temperature:	-10° C ... +50° C
Installation positioning:	Vertical
Materials:	Body and Shell: Technopolymer
	Gaskets: NBR
	Filter: Sintered bronze
	End parts: Die-cast zinc

	F-1	F-2	F-3
A	72	89	100
B	146	178,5	197
C	45	59	70
D	76	89	106*
E	21	27,5	32,5
F	22,5	28,5	35
H	39	48	50
I	43	55	65
J	54	69	79
K	17,25	22	27
L	D X M4	D X M5	D X M6
W	(1/8")-1/4"-3/8"	(1/4")-3/8"-1/2"	1/2"-3/4"-1"

*) Variante G1" plus 5 mm

Family	Port Size	Flow Rate qnN*	Bowl Capacity	Drain	Part Number
1	G 1/4 "	1900 l/min	22 cm ³	Semi-auto	F-1-1/4
1	G 3/8"	1900 l/min	22 cm ³	Semi-auto	F-1-3/8
2	G 3/8"	3750 l/min	46 cm ³	Semi-auto	F-2-3/8
2	G 1/2"	3750 l/min	46 cm ³	Semi-auto	F-2-1/2
2	G 1/2"	3750 l/min	46 cm ³	Auto	F-2-1/2-A
3	G 3/4"	6250 l/min	89,5 cm ³	Semi-auto	F-3-3/4
3	G 3/4"	6250 l/min	89,5 cm ³	Auto	F-3-3/4-A
3	G 1"	6250 l/min	89,5 cm ³	Semi-auto	F-3-1
3	G 1"	6250 l/min	89,5 cm ³	Auto	F-3-1-A

* Measured at p1=10 bar, p2=6 bar, Δp=1 bar according to CETOP RP 50P

Lubricators

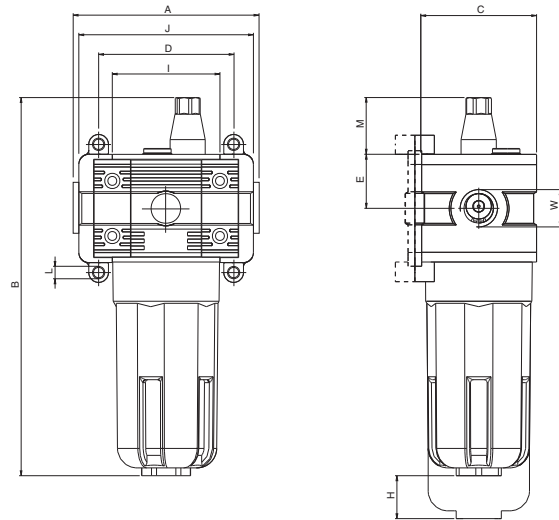

Main features

Direct-proportional lubricator, recommended types of oil: Mineral oils of viscosity class VG 22 a (ISO 3448).
Recommended consumption: 1-2 drops / m³ air.

Technical information

Operating pressure in p1: Max. 15 bar at 20° C
Operating medium: Compressed air
Operating temperature: -10° C ... + 50° C
Installation positioning: Vertical
Materials:
Body and Shell: Technopolymer
Gaskets: Perbunan
End parts: Die-casted zinc

	L-1	L-2	L-3
A	72	89	100
B	162	195	214
C	45	59	70
D	76	89	106 *
E	21	27,5	32,5
H	39	48	50,5
I	43	55	65
J	54	69	79
K	17,25	22	27
L	D X M4	D X M5	D X M6
M	29	29	29
W	(1/8")-1/4"-3/8"(1/4")-3/8"-1/2"1/2"-3/4"-1"		

*) Variante G1" plus 5 mm

Family	Port Size	Flow Rate qnN*	Bowl Capacity	Oil Load	Part Number
1	G 1/4 "	2600 l/min	22 cm ³	Manual	L-1-1/4
1	G 3/8"	2600 l/min	22 cm ³	Manual	L-1-3/8
1	G 3/8"	2600 l/min	22 cm ³	Auto	L-1-3/8-A
2	G 3/8"	5600 l/min	46 cm ³	Manual	L-2-3/8
2	G 1/2"	5600 l/min	46 cm ³	Manual	L-2-1/2
2	G 1/2"	5600 l/min	46 cm ³	Auto	L-2-1/2-A
3	G 3/4"	8200 l/min	89,5 cm ³	Manual	L-3-3/4
3	G 1"	8200 l/min	89,5 cm ³	Manual	L-3-1
3	G 1"	8200 l/min	89,5 cm ³	Auto	L-3-1-A

* Measured at p1=10 bar, p2=6 bar, Δp=1 bar according to CETOP RP 50P

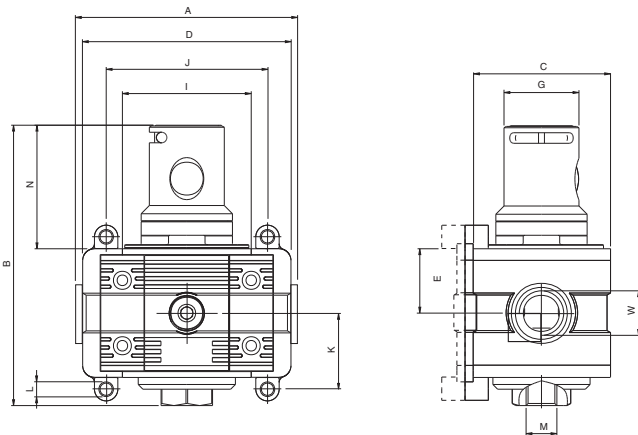
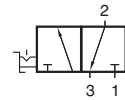

Main features

3/2-way directional valve, indexed in the two final positions, manual operation, lockable.

Technical information

Operating pressure in p1:	Max. 15 bar at 20° C
Operating medium:	Compressed air
Operating temperature:	-10° C ... + 50° C
Installation positioning:	Vertical
Materials:	Body and Knob: Technopolymer Gaskets: NBR End parts: Die-cast zinc

	HE-1	HE-2	HE-3
A	72	89	100
B	105,5	119,5	131,5
C	45	59	70
D	76	89	106*
E	21	27,5	32,5
G	32	32	32
I	43	55	65
J	54	69	79
K	17,25	22	27
L	DXM4	DXM5	DXM6
N	52,5	52,5	52,5
W	(1/8")-1/4"-3/8"(1/4")-3/8"-1/2"1/2"-3/4"-1"		

*) Variante G1" plus 5 mm

Family	Port Size	Flow rate qnN*	Part Number
1	G 1/4"	1850 l/min	HE-1-1/4
1	G 3/8"	1850 l/min	HE-1-3/8
2	G 3/8"	3000 l/min	HE-2-3/8
2	G 1/2"	3000 l/min	HE-2-1/2
3	G 1/2"	5200 l/min	HE-3-1/2
3	G 3/4"	5200 l/min	HE-3-3/4
3	G 1"	5200 l/min	HE-3-1

* Measured at p1=10 bar, p2=6 bar, Δp=1 bar according to CETOP RP 50P

Soft Start Valve

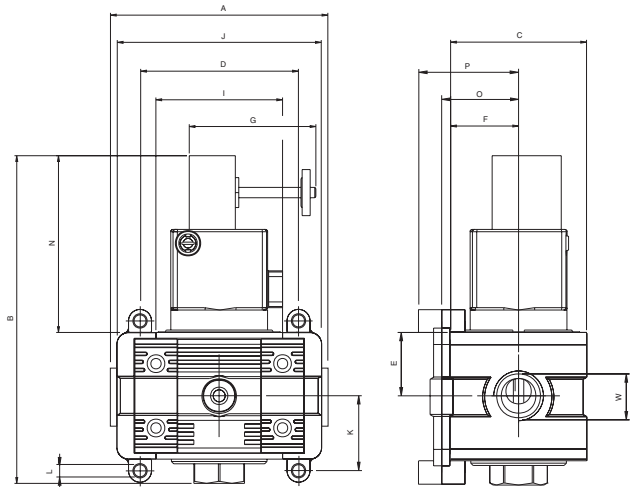

Main features

Soft start valve with quick exhaust,
electropneumatic operation.

Technical information

Operating pressure in p1: Max. 10 bar at 20° C
 Operating medium: Compressed air
 Operating temperature: -10° C ... + 50° C
 Installation positioning: Vertical
 Materials: Body: Technopolymer
 Gaskets: NBR
 End parts: Die-cast zinc

	SSV-2	SSV-3
A	104	115
B	142	131,5
C	59	70
D	89	106 106 111
E	27,5	32,5
F	28,5	35
G	55,5	55,5
I	55	65
J	97	109
K	22	27
L	D X M5	D X M5
N	76,5	76,5
W	1/4" - 3/8" - 1/2"	1/2" - 3/4" - 1"

Family	Port Size	Voltage	Part Number
2	G 3/8"	24VDC	SSV-2-3/8
2	G 1/2"	24VDC	SSV-2-1/2
3	G 3/4"	24VDC	SSV-3-3/4
3	G 1"	24VDC	SSV-3-1

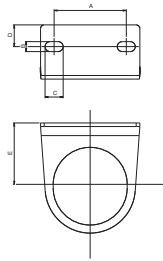

Mounting bracket

Material: Galvanised steel
 Use: For wall mounting for single regulator units or combinations with regulator units.
 Scope of del.: 1 mounting bracket

Family	A	B	C	D	E	Model
0	28	5,5	18,5	13	32	BW-0
1	28	5,5	10	10	29	BW-1
2	40	5,5	10	12	35	BW-2
3	50	5,5	10	15	39	BW-3

Pressure gauge



Accuracy class: 1,6
 Diameter: 40 mm
 Connecting thread: G 1/8 "
 Indicator range: 0 ... 12 bar
 Model: M-1/8-12

Filter elements



Material: Sintered bronze
 Use / function: For filtering contamination out of compressed air
 Filter fineness: 50 µm (standard), 5 µm and 20 µm



Family	Filter Fineness	Part Number
0	5 µm	FE-0-5
0	20 µm	FE-0-20
0	50 µm	FE-0-50
1	5 µm	FE-1-5
1	20 µm	FE-1-20
1	50 µm	FE-1-50
2	5 µm	FE-2-5
2	20 µm	FE-2-20
2	50 µm	FE-2-50
3	5 µm	FE-3-5
3	20 µm	FE-3-20
3	50 µm	FE-3-50

Family	Type	Part Number
0	Filter Bowl Semi Auto	FBS-0
1	Filter Bowl Semi Auto	FBS-1
2	Filter Bowl Semi Auto	FBS-2
3	Filter Bowl Semi Auto	FBS-3
2	Filter Bowl Auto Drain	FBA-2
3	Filter Bowl Auto Drain	FBA-3
0	Lubricator Bowl Manuel	LBM-0
1	Lubricator Bowl Manuel	LBM-1
2	Lubricator Bowl Manuel	LBM-2
3	Lubricator Bowl Manuel	LBM-3
1	Lubricator Bowl Auto	LBA-1
2	Lubricator Bowl Auto	LBA-2
3	Lubricator Bowl Auto	LBA-3

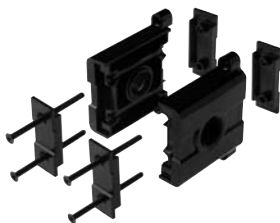

Family	Port Size	Type	Part Number
1	G 1/8"	Connector Unit	VU-1-1/8
1	G 1/4"	Connector Unit	VU-1-1/4
1	G 3/8 "	Connector Unit	VU-1-3/8
2	G 1/4"	Connector Unit	VU-2-1/4
2	G 3/8"	Connector Unit	VU-2-3/8
2	G 1/2"	Connector Unit	VU-2-1/2
3	G 1/2"	Connector Unit	VU-3-1/2
3	G 3/4"	Connector Unit	VU-3-3/4
3	G 1"	Connector Unit	VU-3-1



Family	Type	Part Number
0	Connector Plate	VP-0
1	Connector Plate	VP-1
2	Connector Plate	VP-2
3	Connector Plate	VP-3