

Air Cooled

MB ERGO MIG/MAG Welding Torches

ERGO LINE



MB ERGO 15 AK

Technical Data (EN 60 974-7)

| Rating | Duty Cycle | Wire Size |
|-----------------------|------------|--------------|
| 180 A CO ² | 60% | 0.6 - 1.2 mm |
| 150 A Mixed Gas | | |



Flexible and durable rubber Bikox®.

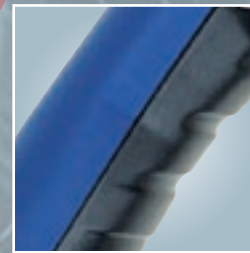

Original ERGO handle - comfortable in every position.

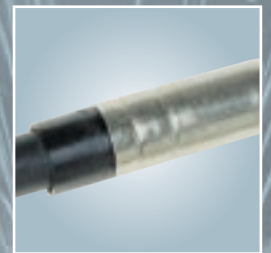

Generic industry standard and proven consumables.

+ Special length manual & automatic torches are available on request.

Manual Torches

| Torch | 3 Metre | 4 Metre | 5 Metre |
|----------------------|----------|----------|----------|
| MB ERGO 15 AK | 002.0449 | 002.0450 | 002.0451 |

+ When ordering complete automatic torches, please indicate torch type, neck angle and length.

Automatic Torches

| Torch | 3 Metre |
|------------------------|----------|
| AUT 15 AK / Str | 902.0022 |
| AUT 15 AK / 45° | 902.0023 |

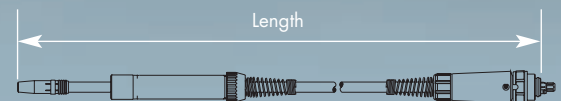

Technology for the welder's world.



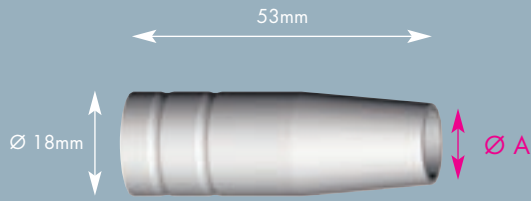

Gas Nozzles

Pack Size = 10

| Ø A | Type | Part Number |
|---------|--------------------|-------------|
| Ø 16mm | Cylindrical | 145.0041 |
| Ø 12mm | Conical | 145.0075 |
| Ø 9.5mm | Tapered | 145.0123 |

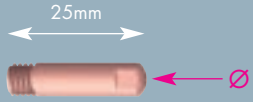

M6 Contact Tips

Pack Size = 50

+ A full range of our M6 contact tips is available.

| Diameter | Standard (E-Cu) | Heavy Duty (CuCrZr) | Aluminium |
|----------|-----------------|---------------------|-----------|
| Ø 0.6 mm | 140.0008 | - | - |
| Ø 0.8 mm | 140.0059 | 140.0062 | 141.0002 |
| Ø 1.0 mm | 140.0253 | 140.0256 | 141.0007 |
| Ø 1.2 mm | 140.0387 | 140.0390 | 141.0011 |

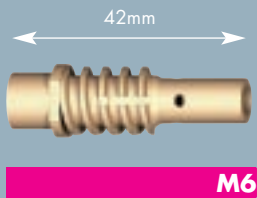

Nozzle Holder

Pack Size = 2



Nozzle Spring

Pack Size = 10

| | Std | Std |
|-----------|----------|----------|
| M6 | 002.0078 | 002.0058 |



PVC Coated Liners

Protects against gas leakage through liner wall

| Colour | Diameter Ø | 3 Metre | 4 Metre | 5 Metre | 50 Metre Coil |
|--------|--------------|----------|----------|----------|---------------|
| Blue | 0.6 - 0.8 mm | 124.0011 | 124.0012 | 124.0015 | 123.0004 |
| Orange | 1.0 - 1.2 mm | 124.0026 | 124.0031 | 124.0035 | 123.0010 |



PTFE Liners

To be used for Aluminium welding

| Colour | Diameter Ø | 3 Metre | 4 Metre | 5 Metre | 50 Metre Coil |
|--------|--------------|----------|----------|----------|---------------|
| Blue | 0.6 - 0.8 mm | 126.0005 | 126.0008 | 126.0011 | 125.0004 |
| Orange | 1.0 - 1.2 mm | 126.0021 | 126.0026 | 126.0028 | 125.0006 |

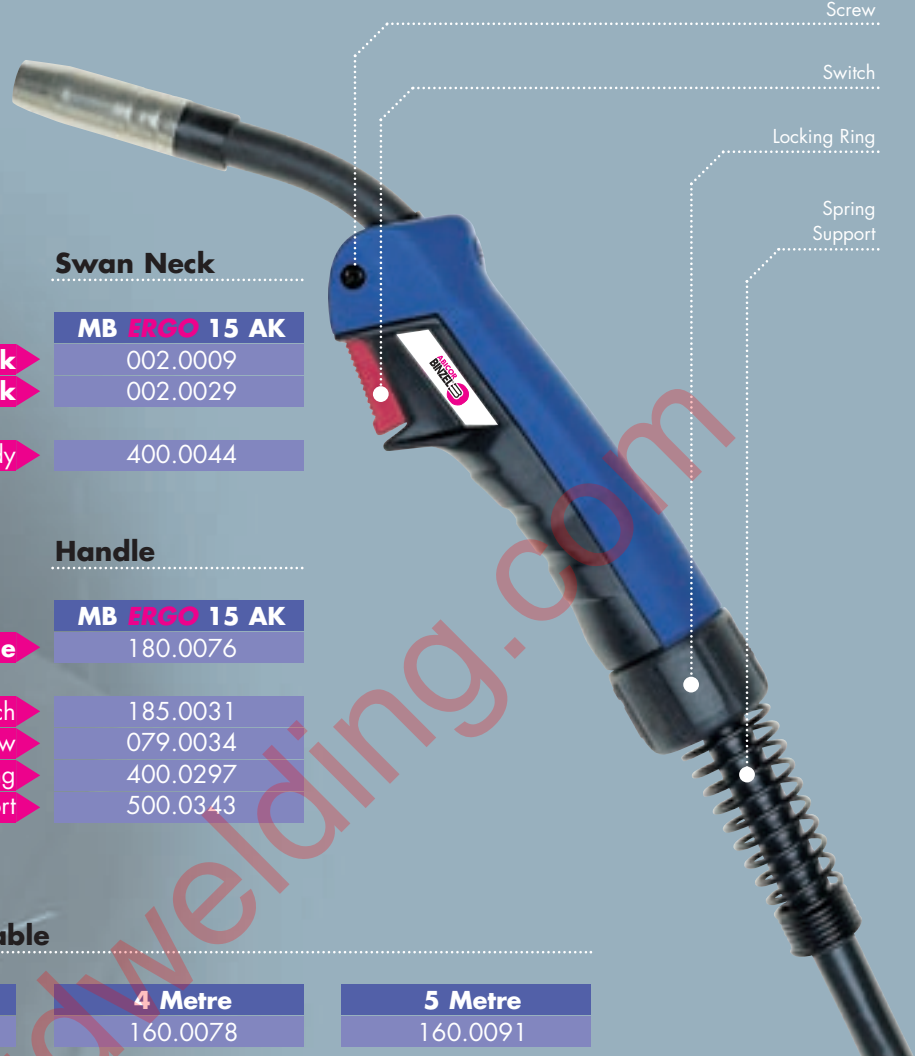

Swan Neck

| | MB ERGO 15 AK |
|--------------------|---------------|
| 50° Swan Neck | 002.0009 |
| Flexible Swan Neck | 002.0029 |
| Torch Body | 400.0044 |

Handle

| | MB ERGO 15 AK |
|-----------------|---------------|
| Complete Handle | 180.0076 |
| Switch | 185.0031 |
| Screw | 079.0034 |
| Locking Ring | 400.0297 |
| Spring Support | 500.0343 |

Bikox® Power Cable

| | 3 Metre | 4 Metre | 5 Metre |
|-------------|----------|----------|----------|
| Power Cable | 160.0065 | 160.0078 | 160.0091 |

Gun Plug Assembly

| | MB ERGO 15 AK |
|---------------|---------------|
| Gun Plug Body | 501.0003 |
| Liner Nut | 501.0082 |
| Spring Pins | 501.2378 |
| Locking Nut | 500.0127 |
| Black Housing | 501.2454 |
| Locking Ring | 400.0987 |
| Cable Support | 400.1010 |

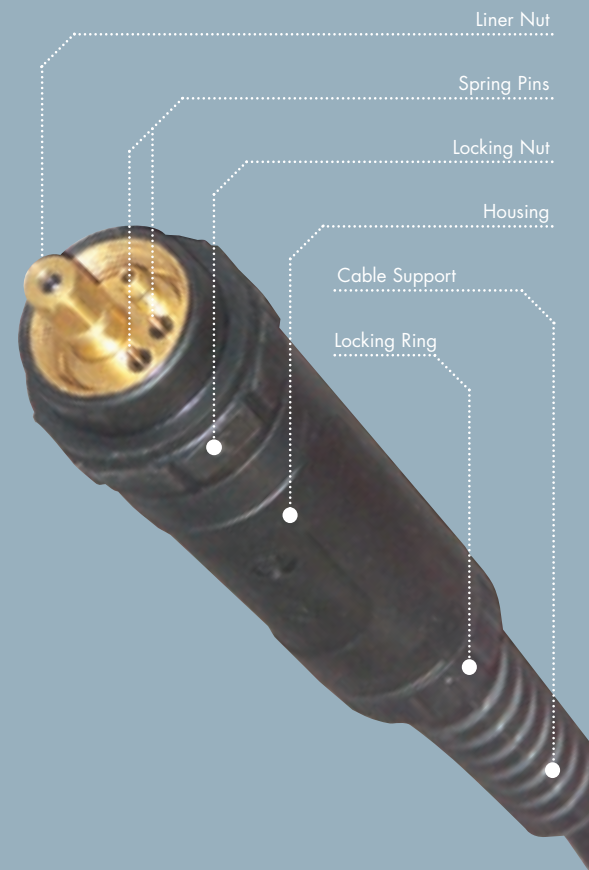

+ The consumables for the automatic torches are the same as the manual torches.

Automatic Version

| | AUT 15 AK |
|---------------|-----------|
| Straight Neck | 902.0003 |
| 45° Neck | 902.0004 |
| Handle | 180.0097 |
| Locking Ring | 400.0137 |



Technology & Quality

MB **ERGO** MIG/MAG Welding Torches Worldwide recognised.

- The Ergonomic handle – positive handling even in extreme circumstances.
- Air cooled up to 270 A.
- Liquid cooled up to 500 A.
- Optimum cooling of the torch – extending torch life.
- Time-saving torch change-over due to the ABICOR BINZEL central connector.
- Ergonomically and technically mature and reliable.
- Leading quality recognised worldwide.

Introducing the rest of the **ERGO** range...



1. MB **ERGO** 25 AK
Air Cooled
2. MB **ERGO** 36 KD
Air Cooled
3. MB **ERGO** 36 KD
'Compact'
Air Cooled
4. MB **ERGO** 401 D
Liquid Cooled
5. MB **ERGO** 501 D
Liquid Cooled

Technology for the welder's world.

**ABICOR
BINZEL**

ERGO LINE

Alexander Binzel UK Ltd, Binzel House, Mill Lane, Winwick Quay, Warrington, Cheshire. WA2 8UA.
Tel : (01925) 653944 Fax : (01925) 654861 e-mail : info@binzelabikor.com website : www.binzel-abikor.com

**IBG
GROUP**

Air Cooled

MB ERGO MIG/MAG Welding Torches

ERGO LINE



MB ERGO 25 AK

Technical Data (EN 60 974-7)

| Rating | Duty Cycle | Wire Size |
|-----------------------|------------|--------------|
| 230 A CO ² | 60% | 0.8 - 1.2 mm |
| 200 A Mixed Gas | | |



Flexible and durable rubber Bikox®.



Original ERGO handle - comfortable in every position.

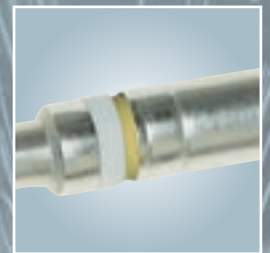

Generic industry standard and proven consumables.

+ Special length manual & automatic torches are available on request.

Manual Torches

| Torch | 3 Metre | 4 Metre | 5 Metre |
|----------------------|----------|----------|----------|
| MB ERGO 25 AK | 004.0312 | 004.0313 | 004.0314 |

+ When ordering complete automatic torches, please indicate torch type, neck angle and length.

Automatic Torches

| Torch | 3 Metre |
|------------------------|----------|
| AUT 25 AK / Str | 904.0003 |
| AUT 25 AK / 45° | 904.0004 |

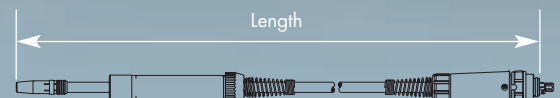

Technology for the welder's world.



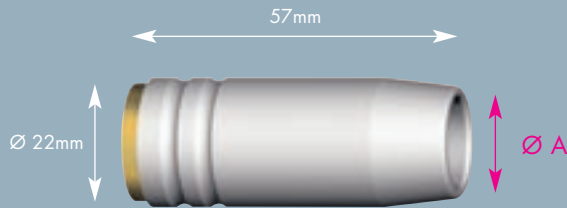

Gas Nozzles

Pack Size = 10

| Ø A | Type | Part Number |
|----------|--------------------|-------------|
| Ø 18mm | Cylindrical | 145.0042 |
| Ø 15mm | Conical | 145.0076 |
| Ø 11.5mm | Tapered | 145.0124 |

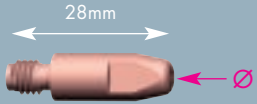

M6 Contact Tips

Pack Size = 50 (ABITIP® plus = 10)



A full range of our **M6** contact tips is available.

| Diameter | Standard (E-Cu) | Heavy Duty (CuCrZr) | Aluminium | ABITIP® plus |
|----------|-----------------|---------------------|-----------|--------------|
| Ø 0.8 mm | 140.0051 | 140.0054 | 141.0001 | 144.0054 |
| Ø 1.0 mm | 140.0242 | 140.0245 | 141.0006 | 144.0245 |
| Ø 1.2 mm | 140.0379 | 140.0382 | 141.0010 | 144.0382 |

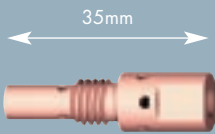

Tip Holder

Pack Size = 10



Nozzle Spring

Pack Size = 10

| | Std | Std |
|-----------|----------|----------|
| M6 | 142.0001 | 003.0013 |
| M8 | 142.0015 | |



PVC Coated Liners

Protects against gas leakage through liner wall

| Colour | Diameter Ø | 3 Metre | 4 Metre | 5 Metre | 50 Metre Coil |
|--------|---------------------|----------|----------|----------|---------------|
| Blue | 0.6 - 0.8 mm | 124.0011 | 124.0012 | 124.0015 | 123.0004 |
| Orange | 1.0 - 1.2 mm | 124.0026 | 124.0031 | 124.0035 | 123.0010 |



PTFE Liners

To be used for Aluminium welding

| Colour | Diameter Ø | 3 Metre | 4 Metre | 5 Metre | 50 Metre Coil |
|--------|---------------------|----------|----------|----------|---------------|
| Blue | 0.6 - 0.8 mm | 126.0005 | 126.0008 | 126.0011 | 125.0004 |
| Orange | 1.0 - 1.2 mm | 126.0021 | 126.0026 | 126.0028 | 125.0006 |

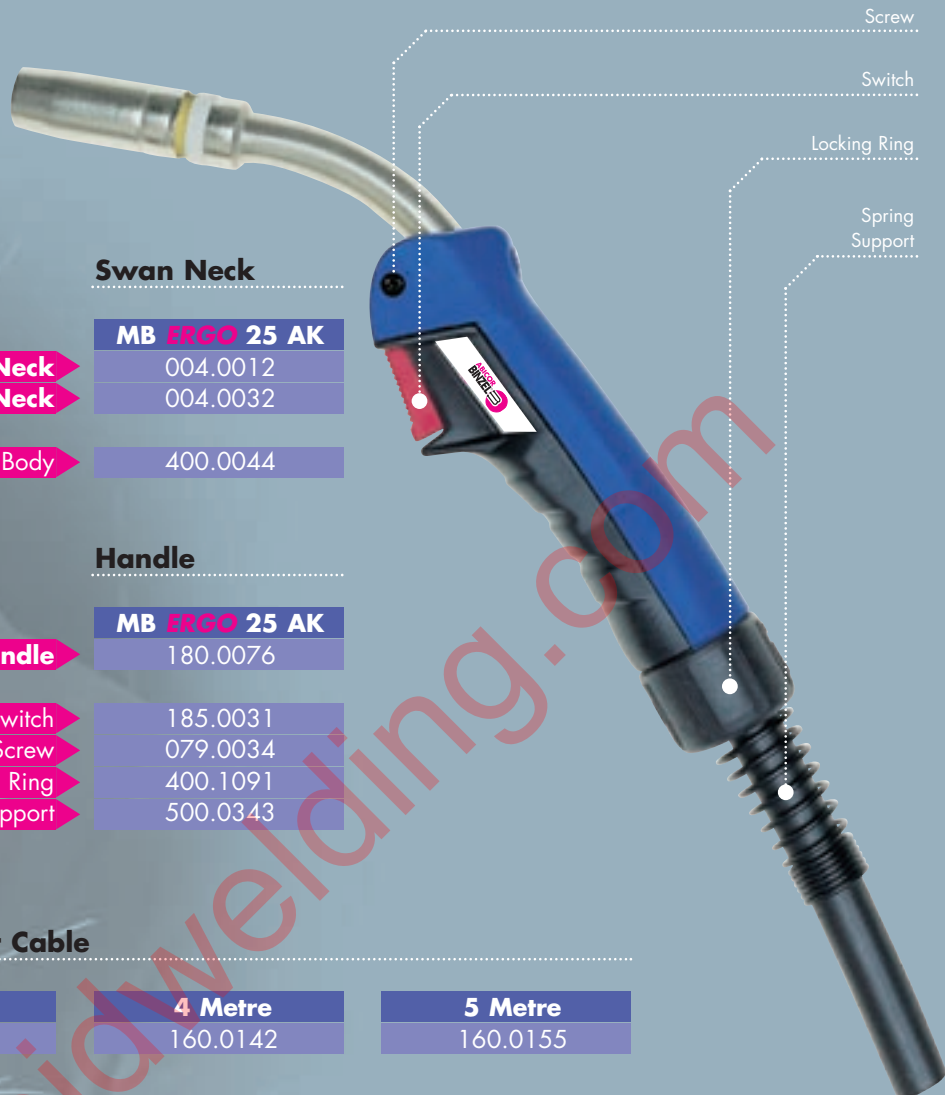

Swan Neck

| | MB ERGO 25 AK |
|--------------------|---------------|
| 50° Swan Neck | 004.0012 |
| Flexible Swan Neck | 004.0032 |
| Torch Body | 400.0044 |

Handle

| | MB ERGO 25 AK |
|-----------------|---------------|
| Complete Handle | 180.0076 |
| Switch | 185.0031 |
| Screw | 079.0034 |
| Locking Ring | 400.1091 |
| Spring Support | 500.0343 |

Bikox® Power Cable

| Power Cable | 3 Metre | 4 Metre | 5 Metre |
|-------------|----------|----------|----------|
| | 160.0128 | 160.0142 | 160.0155 |

Gun Plug Assembly

| | MB ERGO 25 AK |
|---------------|---------------|
| Gun Plug Body | 501.0003 |
| Liner Nut | 501.0082 |
| Spring Pins | 501.2378 |
| Locking Nut | 500.0213 |
| Black Housing | 501.2454 |
| Locking Ring | 400.0987 |
| Cable Support | 400.1010 |

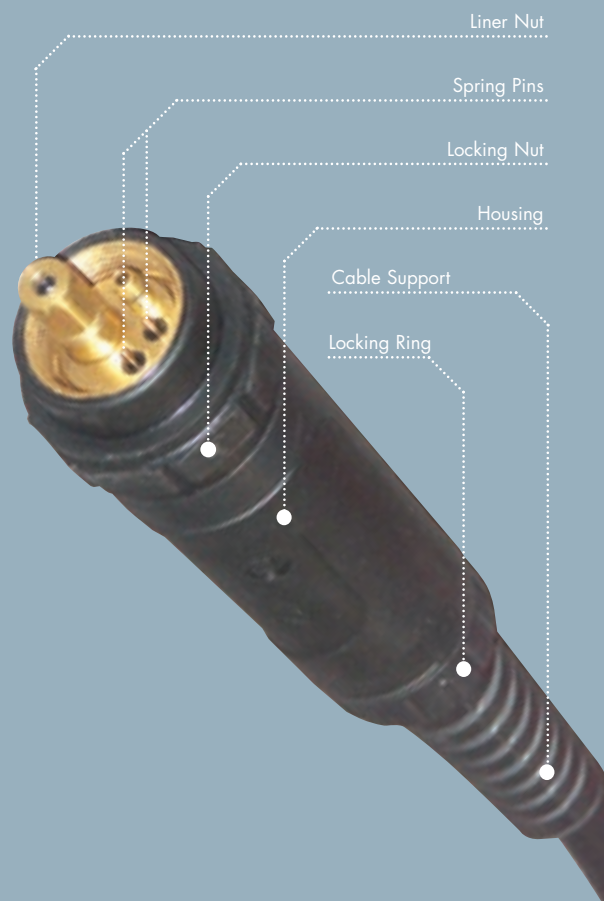

+ The consumables for the automatic torches are the same as the manual torches.

Automatic Version

| | AUT 25 AK |
|---------------|-----------|
| Straight Neck | 904.0003 |
| 45° Neck | 904.0004 |
| Handle | 180.0097 |
| Locking Ring | 400.0137 |



Technology & Quality.

MB **ERGO** MIG/MAG Welding Torches Worldwide recognised.

- The Ergonomic handle – positive handling even in extreme circumstances.
- Air cooled up to 270 A.
- Liquid cooled up to 500 A.
- Optimum cooling of the torch – extending torch life.
- Time-saving torch change-over due to the ABICOR BINZEL central connector.
- Ergonomically and technically mature and reliable.
- Leading quality recognised worldwide.

Introducing the rest of the **ERGO** range...



1. MB **ERGO** 15 AK
Air Cooled
2. MB **ERGO** 36 KD
Air Cooled
3. MB **ERGO** 36 KD
'Compact'
Air Cooled
4. MB **ERGO** 401 D
Liquid Cooled
5. MB **ERGO** 501 D
Liquid Cooled

Technology for the welder's world.

ABICOR
BINZEL

ERGO LINE

Alexander Binzel UK Ltd, Binzel House, Mill Lane, Winwick Quay, Warrington, Cheshire. WA2 8UA.
Tel : (01925) 653944 Fax : (01925) 654861 e-mail : info@binzelabikor.com website : www.binzelabikor.com

IBG
GROUP

Air Cooled

MB ERGO MIG/MAG Welding Torches

ERGO LINE



MB ERGO 36 KD

Technical Data (EN 60 974-7)

| Rating | Duty Cycle | Wire Size |
|------------------------------------------|------------|--------------|
| 320 A CO ² 290 A Mixed Gas | 60% | 0.8 - 1.2 mm |



Flexible and durable rubber Bikox®.

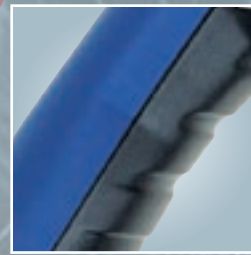

Original ERGO handle - comfortable in every position.



Generic industry standard and proven consumables.

+ Special length manual & automatic torches are available on request.

Manual Torches

| Torch | 3 Metre | 4 Metre | 5 Metre |
|----------------------|----------|----------|----------|
| MB ERGO 36 KD | 014.0143 | 014.0144 | 014.0145 |

+ When ordering complete automatic torches, please indicate torch type, neck angle and length.

Automatic Torches

| Torch | 3 Metre |
|------------------------|----------|
| AUT 36 KD / Str | 914.0013 |
| AUT 36 KD / 45° | 914.0014 |

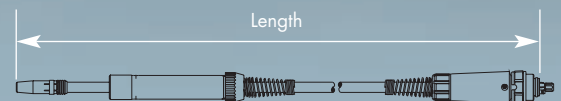

Technology for the welder's world.



Gas Nozzles

Pack Size = 10

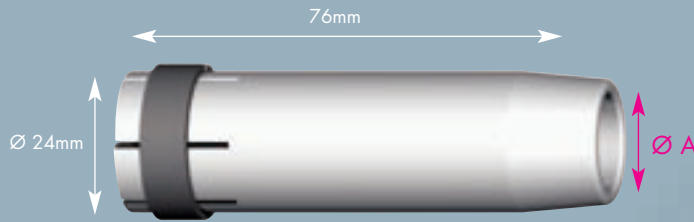

| Ø A | Type |
|--------|--------------------|
| Ø 19mm | Cylindrical |
| Ø 16mm | Conical |
| Ø 12mm | Tapered |

| Part Number |
|-------------|
| 145.0045 |
| 145.0078 |
| 145.0126 |

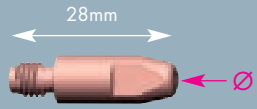

M6 Contact Tips

Pack Size = 50 (ABITIP® plus = 10)

+ A full range of our M6 contact tips is available.

| Diameter |
|----------|
| Ø 0.8 mm |
| Ø 1.0 mm |
| Ø 1.2 mm |

| Standard (E-Cu) |
|-----------------|
| 140.0051 |
| 140.0242 |
| 140.0379 |

| Heavy Duty (CuCrZr) |
|---------------------|
| 140.0054 |
| 140.0245 |
| 140.0382 |

| Aluminium |
|-----------|
| 141.0001 |
| 141.0006 |
| 141.0010 |

| ABITIP® plus |
|--------------|
| 144.0054 |
| 144.0245 |
| 144.0382 |

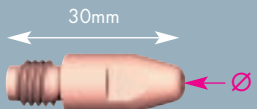

M8 Contact Tips

Pack Size = 50 (ABITIP® plus = 10)

+ A full range of our M8 contact tips is available.

| Diameter |
|----------|
| Ø 0.8 mm |
| Ø 1.0 mm |
| Ø 1.2 mm |

| Standard (E-Cu) |
|-----------------|
| 140.0114 |
| 140.0313 |
| 140.0442 |

| Heavy Duty (CuCrZr) |
|---------------------|
| 140.0117 |
| 140.0316 |
| 140.0445 |

| Aluminium |
|-----------|
| 141.0003 |
| 141.0008 |
| 141.0015 |

| ABITIP® plus |
|--------------|
| 144.0117 |
| 144.0316 |
| 144.0445 |

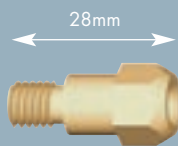

Std Tip Adaptor

Pack Size = 10

| |
|-----------|
| M6 |
| M8 |

| Std |
|----------|
| 142.0005 |
| 142.0020 |

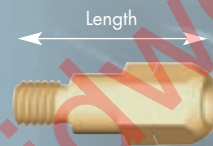

Long Tip Adaptor

Pack Size = 10

| Length | M6 | M8 |
|--------|-----------|-----------|
| 32mm | M6 | M8 |
| 34mm | M6 | M8 |

| Long |
|----------|
| 142.0011 |
| 142.0024 |

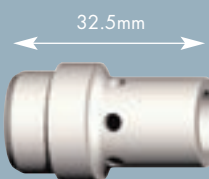

Gas Diffusor

Pack Size = 10

| |
|-----------------|
| Standard |
| Ceramic |

| Part Number |
|-------------|
| 014.0261 |
| 014.0023 |

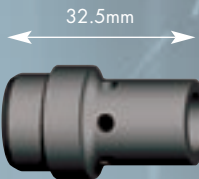

HD Gas Diffusor

Pack Size = 10

| |
|-------------------|
| Heavy Duty |
|-------------------|

| Part Number |
|-------------|
| 014.0026 |

PVC Coated Liners

Protect against gas leakage through liner wall



| Colour | Diameter Ø |
|--------|---------------------|
| | 0.6 - 0.8 mm |
| | 1.0 - 1.2 mm |

| 3 Metre |
|----------|
| 124.0011 |
| 124.0026 |

| 4 Metre |
|----------|
| 124.0012 |
| 124.0031 |

| 5 Metre |
|----------|
| 124.0015 |
| 124.0035 |

| 50 Metre Coil |
|---------------|
| 123.0004 |
| 123.0010 |

PTFE Liners

To be used for Aluminium welding



| Colour | Diameter Ø |
|--------|---------------------|
| | 0.6 - 0.8 mm |
| | 1.0 - 1.2 mm |

| 3 Metre |
|----------|
| 126.0005 |
| 126.0021 |

| 4 Metre |
|----------|
| 126.0008 |
| 126.0026 |

| 5 Metre |
|----------|
| 126.0011 |
| 126.0028 |

| 50 Metre Coil |
|---------------|
| 125.0004 |
| 125.0006 |



Swan Neck

| | |
|----------------------|----------------------------------|
| 50° Swan Neck | MB ERGO 36 KD 014.0006 |
|----------------------|----------------------------------|

Handle

| | |
|------------------------|----------------------------------|
| Complete Handle | MB ERGO 36 KD 180.0076 |
| Switch | 185.0031 |
| Screw | 079.0034 |
| Locking Ring | 400.0297 |
| Spring Support | 500.0343 |

Bikox® Power Cable

| | | | |
|--------------------|----------------------------|----------------------------|----------------------------|
| Power Cable | 3 Metre 160.0364 | 4 Metre 160.0379 | 5 Metre 160.0391 |
|--------------------|----------------------------|----------------------------|----------------------------|

Gun Plug Assembly

| | |
|----------------------|----------------------------------|
| Gun Plug Body | MB ERGO 36 KD 501.0003 |
| Liner Nut | 501.0082 |
| Spring Pins | 501.2378 |
| Locking Nut | 500.0213 |
| Black Housing | 501.2454 |
| Locking Ring | 400.0987 |
| Cable Support | 400.1010 |

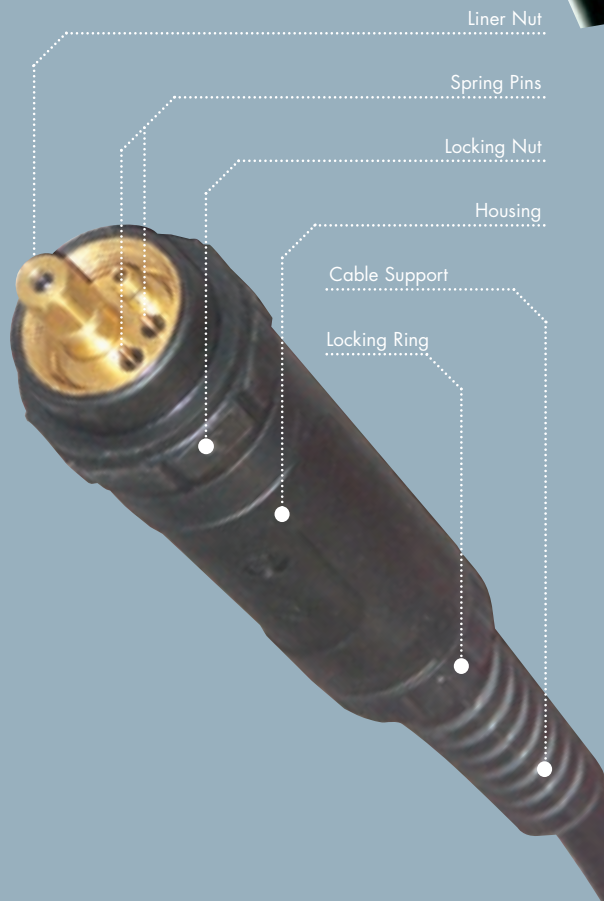

+ The consumables for the automatic torches are the same as the manual torches.

Automatic Version

| | |
|----------------------|------------------|
| | AUT 36 KD |
| Straight Neck | 914.0002 |
| 22° Neck | 914.0025 |
| 45° Neck | 914.0001 |
| Handle | 180.0097 |
| Locking Ring | 400.0137 |



Technology & Quality.

MB **ERGO** MIG/MAG Welding Torches Worldwide recognised.

- The Ergonomic handle – positive handling even in extreme circumstances.
- Air cooled up to 270 A.
- Liquid cooled up to 500 A.
- Optimum cooling of the torch – extending torch life.
- Time-saving torch change-over due to the ABICOR BINZEL central connector.
- Ergonomically and technically mature and reliable.
- Leading quality recognised worldwide.

Introducing the rest of the **ERGO** range...



1. MB **ERGO** 15 AK
Air Cooled
2. MB **ERGO** 25 AK
Air Cooled
3. MB **ERGO** 36 KD
'Compact'
Air Cooled
4. MB **ERGO** 401 D
Liquid Cooled
5. MB **ERGO** 501 D
Liquid Cooled

Technology for the welder's world.

**ABICOR
BINZEL**

ERGO LINE

Alexander Binzel UK Ltd, Binzel House, Mill Lane, Winwick Quay, Warrington, Cheshire, WA2 8UA.
Tel : (01925) 653944 Fax : (01925) 654861 e-mail : info@binzelabikor.com website : www.binzel-abikor.com

**IBG
GROUP**

Air Cooled

MB ERGO MIG/MAG Welding Torches

ERGO LINE

+ Shorter neck than the standard MB ERGO 36.



MB 36 Compact

Technical Data (EN 60 974-7)

| Rating | Duty Cycle | Wire Size |
|-----------------------|------------|--------------|
| 230 A CO ² | 35% | 0.8 - 1.2 mm |
| 200 A Mixed Gas | | |



Flexible and durable rubber Bikox®.

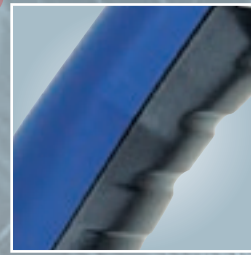

Original ERGO handle - comfortable in every position.



Generic industry standard and proven consumables.

+ Special length manual & automatic torches are available on request.

Manual Torches

| Torch | 3 Metre | 4 Metre | 5 Metre |
|----------------------|----------|----------|----------|
| MB 36 Compact | 018.0135 | 018.0136 | 018.0137 |

Technology for the welders world.



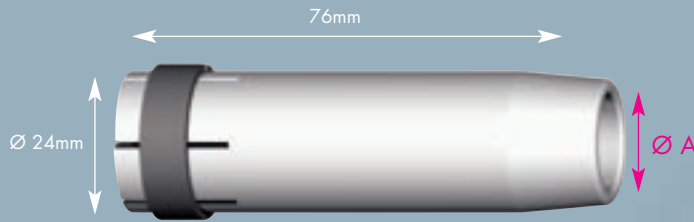

| Ø A | Type |
|--------|--------------------|
| Ø 19mm | Cylindrical |
| Ø 16mm | Conical |
| Ø 12mm | Tapered |

Gas Nozzles

Pack Size = 10

| Part Number |
|-------------|
| 145.0045 |
| 145.0078 |
| 145.0126 |

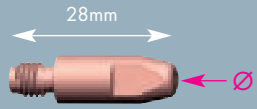

M6 Contact Tips

Pack Size = 50 (ABITIP plus = 10)

+ A full range of our **M6** contact tips is available.

| Diameter |
|----------|
| Ø 0.8 mm |
| Ø 1.0 mm |
| Ø 1.2 mm |

| Standard (E-Cu) |
|-----------------|
| 140.0051 |
| 140.0242 |
| 140.0379 |

| Heavy Duty (CuCrZr) |
|---------------------|
| 140.0054 |
| 140.0245 |
| 140.0382 |

| Aluminium |
|-----------|
| 141.0001 |
| 141.0006 |
| 141.0010 |

| ABITIP® plus |
|--------------|
| 144.0054 |
| 144.0245 |
| 144.0385 |

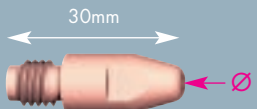

M8 Contact Tips

Pack Size = 50 (ABITIP plus = 10)

+ A full range of our **M8** contact tips is available.

| Diameter |
|----------|
| Ø 0.8 mm |
| Ø 1.0 mm |
| Ø 1.2 mm |

| Standard (E-Cu) |
|-----------------|
| 140.0114 |
| 140.0313 |
| 140.0442 |

| Heavy Duty (CuCrZr) |
|---------------------|
| 140.0117 |
| 140.0316 |
| 140.0445 |

| Aluminium |
|-----------|
| 141.0003 |
| 141.0008 |
| 141.0015 |

| ABITIP® plus |
|--------------|
| 144.0117 |
| 144.0316 |
| 144.0445 |

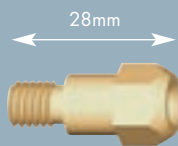

Std Tip Adaptor

Pack Size = 10

| |
|-----------|
| M6 |
| M8 |

| Std |
|----------|
| 142.0005 |
| 142.0020 |

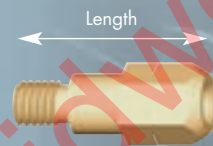

Long Tip Adaptor

Pack Size = 10

| Length | M6 | M8 |
|--------|-----------|-----------|
| 32mm | M6 | M8 |
| 34mm | M6 | M8 |

| Long |
|----------|
| 142.0011 |
| 142.0024 |

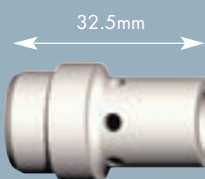

Gas Diffusor

Pack Size = 10

| |
|-----------------|
| Standard |
| Ceramic |

| Part Number |
|-------------|
| 014.0261 |
| 014.0023 |

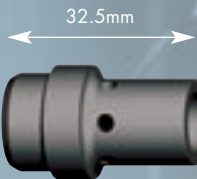

HD Gas Diffusor

Pack Size = 10

| |
|-------------------|
| Heavy Duty |
|-------------------|

| Part Number |
|-------------|
| 014.0026 |



PVC Coated Liners

Protect against gas leakage through liner wall

| Colour | Diameter Ø |
|--------|---------------------|
| | 0.6 - 0.8 mm |
| | 1.0 - 1.2 mm |

| 3 Metre |
|----------|
| 124.0011 |
| 124.0026 |

| 4 Metre |
|----------|
| 124.0012 |
| 124.0031 |

| 5 Metre |
|----------|
| 124.0015 |
| 124.0035 |

| 50 Metre Coil |
|---------------|
| 123.0004 |
| 123.0010 |



PTFE Liners

To be used for Aluminium welding

| Colour | Diameter Ø |
|--------|---------------------|
| | 0.6 - 0.8 mm |
| | 1.0 - 1.2 mm |

| 3 Metre |
|----------|
| 126.0005 |
| 126.0021 |

| 4 Metre |
|----------|
| 126.0008 |
| 126.0026 |

| 5 Metre |
|----------|
| 126.0011 |
| 126.0028 |

| 50 Metre Coil |
|---------------|
| 125.0004 |
| 125.0006 |



Swan Neck

| | |
|----------------------|----------------------------------|
| 50° Swan Neck | MB 36 Compact 018.0001 |
|----------------------|----------------------------------|

Handle

| | |
|------------------------|----------------------------------|
| Complete Handle | MB 36 Compact 180.0076 |
| Switch | 185.0031 |
| Screw | 079.0034 |
| Locking Ring | 400.0297 |
| Cable Support | 500.0343 |

Bikox Power Cable

| | | | |
|--------------------|----------------------------|----------------------------|----------------------------|
| Power Cable | 3 Metre 160.0239 | 4 Metre 160.0255 | 5 Metre 160.0267 |
|--------------------|----------------------------|----------------------------|----------------------------|

Gun Plug Assembly

| | |
|----------------------|----------------------------------|
| Gun Plug Body | MB 36 Compact 501.0003 |
| Liner Nut | 501.0082 |
| Spring Pins | 501.2378 |
| Locking Nut | 500.0213 |
| Black Housing | 501.2454 |
| Locking Ring | 400.0987 |
| Cable Support | 400.1010 |

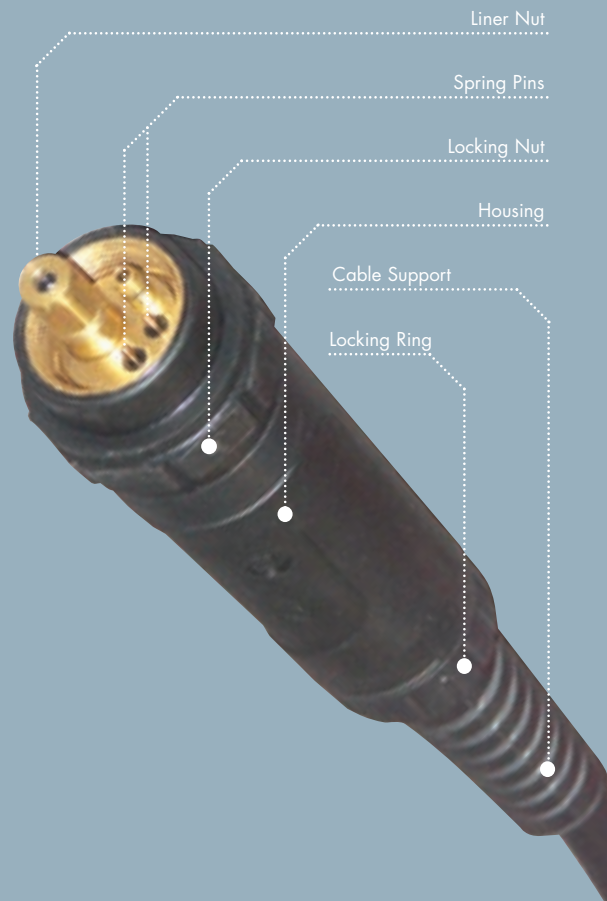

Technology & Quality.

MB **ERGO** MIG/MAG Welding Torches Worldwide recognised.

- The Ergonomic handle – positive handling even in extreme circumstances.
- Air cooled up to 270 A.
- Liquid cooled up to 500 A.
- Optimum cooling of the torch – extending torch life.
- Time-saving torch change-over due to the ABICOR BINZEL central connector.
- Ergonomically and technically mature and reliable.
- Leading quality recognised worldwide.

Introducing the rest of the **ERGO** range...



1. MB **ERGO** 15 AK
Air Cooled
2. MB **ERGO** 25 AK
Air Cooled
3. MB **ERGO** 36 KD
Air Cooled
4. MB **ERGO** 401 D
Liquid Cooled
5. MB **ERGO** 501 D
Liquid Cooled

Technology for the welders world.

ABICOR
BINZEL

ERGO LINE

Alexander Binzel UK Ltd, Binzel House, Mill Lane, Winwick Quay, Warrington, Cheshire, WA2 8UA.
Tel : (01925) 653944 Fax : (01925) 654861 e-mail : info@binzelabikor.com website : www.binzelabikor.com

IBG
GROUP

Liquid Cooled

MB ERGO MIG/MAG Welding Torches

ERGO LINE

+ NEW FOR 2008.
HDH hoses as standard.

MB ERGO 401 D

Technical Data (EN 60 974-7)

| Rating | Duty Cycle | Wire Size |
|------------------------------------------|------------|--------------|
| 400 A CO ² 350 A Mixed Gas | 100% | 0.8 - 1.6 mm |

MB ERGO 501 D

Technical Data (EN 60 974-7)

| Rating | Duty Cycle | Wire Size |
|------------------------------------------|------------|--------------|
| 500 A CO ² 450 A Mixed Gas | 100% | 1.0 - 1.6 mm |



Original **ERGO** handle - comfortable in every position.



Generic industry standard and proven consumables.

+ Special length manual & automatic torches are available on request.

Manual Torches

| Torch | 3 Metre | 4 Metre | 5 Metre |
|----------------------|----------|----------|----------|
| MB ERGO 401 D | 033.0107 | 033.0108 | 033.0109 |
| MB ERGO 501 D | 034.0160 | 034.0161 | 034.0162 |

+ When ordering complete automatic torches, please indicate **torch type**, **neck angle** and **length**.

Automatic Torches

| Torch | 3 Metre |
|--------------------------|----------|
| AUT 401/501 D Str | 934.0032 |
| AUT 401/501 D 45° | 934.0033 |

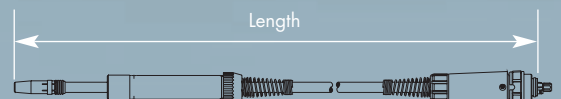

Technology for the welder's world.



Gas Nozzles

Pack Size = 10



| Ø A | Type | Part Number |
|--------|--------------------|-------------|
| Ø 20mm | Cylindrical | 145.0051 |
| Ø 16mm | Conical | 145.0085 |
| Ø 14mm | Tapered | 145.0132 |

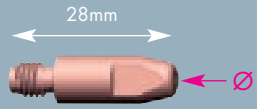

M6 Contact Tips

Pack Size = 50 (ABITIP plus = 10)

+ A full range of our M6 contact tips is available.

| Diameter | Standard (E-Cu) | Heavy Duty (CuCrZr) | Aluminium | ABITIP [®] plus |
|----------|-----------------|---------------------|-----------|--------------------------|
| Ø 0.8 mm | 140.0051 | 140.0054 | 141.0001 | 144.0054 |
| Ø 1.0 mm | 140.0242 | 140.0245 | 141.0006 | 144.0245 |
| Ø 1.2 mm | 140.0379 | 140.0382 | 141.0010 | 144.0382 |
| Ø 1.4 mm | 140.0516 | 140.0519 | 141.0019 | 144.0519 |
| Ø 1.6 mm | 140.0555 | 140.0558 | 141.0020 | 144.0558 |

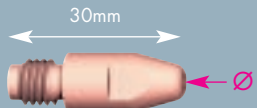

M8 Contact Tips

Pack Size = 50 (ABITIP plus = 10)

+ A full range of our M8 contact tips is available.

| Diameter | Standard (E-Cu) | Heavy Duty (CuCrZr) | Aluminium | ABITIP [®] plus |
|----------|-----------------|---------------------|-----------|--------------------------|
| Ø 0.8 mm | 140.0114 | 140.0117 | 141.0003 | 144.0117 |
| Ø 1.0 mm | 140.0313 | 140.0316 | 141.0008 | 144.0316 |
| Ø 1.2 mm | 140.0442 | 140.0445 | 141.0015 | 144.0445 |
| Ø 1.4 mm | 140.0533 | 140.0536 | 141.0055 | 144.0536 |
| Ø 1.6 mm | 140.0587 | 140.0590 | 141.0022 | 144.0590 |

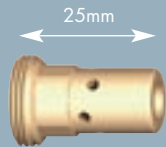

Std Tip Adaptor

Pack Size = 10

| | Std |
|-----------|----------|
| M6 | 142.0008 |
| M8 | 142.0022 |



Long Tip Adaptor

Pack Size = 10

| | Long |
|-----------|----------|
| M6 | 142.0013 |
| M8 | 142.0027 |

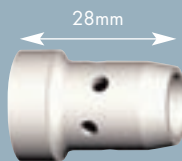

Gas Diffusor

Pack Size = 10

| | Part Number |
|-----------------|-------------|
| Standard | 030.0145 |
| Ceramic | 030.0190 |

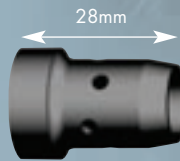

HD Gas Diffusor

Pack Size = 10

| | Part Number |
|-------------------|-------------|
| Heavy Duty | 030.0037 |



Steel Liners

Uncoated liner carry gas separate from the wire/liner

| Colour | Diameter Ø | 3 Metre | 4 Metre | 5 Metre | 50 Metre Coil |
|--------|---------------------|----------|----------|----------|---------------|
| White | 0.6 - 0.8 mm | 122.0005 | 122.0007 | 122.0009 | 120.0009 |
| Grey | 1.0 - 1.2 mm | 122.0031 | 122.0036 | 122.0039 | 120.0026 |
| Black | 1.4 - 1.6 mm | 122.0056 | 122.0060 | 122.0063 | - |



PTFE Liners

To be used for Aluminium welding

| Colour | Diameter Ø | 3 Metre | 4 Metre | 5 Metre | 50 Metre Coil |
|--------|---------------------|----------|----------|----------|---------------|
| Blue | 0.6 - 0.8 mm | 126.0005 | 126.0008 | 126.0011 | 125.0004 |
| Red | 1.0 - 1.2 mm | 126.0021 | 126.0026 | 126.0028 | 125.0006 |
| Yellow | 1.4 - 1.6 mm | 126.0039 | 126.0042 | 126.0045 | 125.0017 |

Swan Neck

| | MB ERGO 401 D | MB ERGO 501 D |
|---------------|----------------------|----------------------|
| 50° Swan Neck | 033.0001 | 034.0001 |
| Insulator | 030.0019 | 030.0019 |

Handle

| | MB ERGO 401 D | MB ERGO 501 D |
|-----------------|----------------------|----------------------|
| Complete Handle | 180.0076 | 180.0076 |
| Switch | 185.0031 | 185.0031 |
| Screw | 079.0034 | 079.0034 |
| Locking Ring | 400.0297 | 400.0297 |

Cable Assembly

| | 3 Metre | 4 Metre | 5 Metre |
|--------------|----------|----------------------|----------|
| Power Cable | 115.0065 | 115.0070 | 115.0074 |
| Wire Conduit | 156.0019 | 156.0023 | 156.0026 |
| Outer Cover | 107.0079 | 107.0044 | 107.0080 |
| Water Hose | | 109.0052 (per metre) | |
| Gas Hose | | 109.0040 (per metre) | |

Water & Gas Hose Parts

| | Water Hose | Gas Hose |
|-----------------|------------|----------|
| Hose Clamp | 173.0001 | 171.0002 |
| Quick Connector | 501.0114 | - |
| Fastening Cap | 501.2423 | - |
| Fastening Cap | 501.2424 | - |
| Hose Marker | 501.2166 | - |
| Hose Marker | 501.2167 | - |

Gun Plug Assembly

| | MB ERGO 401 D | MB ERGO 501 D |
|----------------|----------------------|----------------------|
| Gun Plug Body | 501.0015 | 501.0015 |
| Liner Nut | 501.0082 | 501.0082 |
| Spring Pins | 501.2378 | 501.2378 |
| Locking Nut | 500.0213 | 500.0213 |
| Black Housing | 500.0342 | 500.0342 |
| Spring Support | 500.0233 | 500.0233 |

Automatic Version

| | AUT 501 D |
|----------------|-----------|
| Straight Neck | 934.0001 |
| 22° Neck | 934.0067 |
| 45° Neck | 934.0002 |
| Handle | 180.0097 |
| Support Spring | 500.0233 |

+ A full range of our **Hose Clamps & Quick connectors** is available.

+ The consumables for the automatic torches are the same as the manual torches.

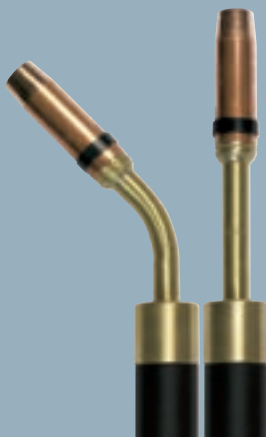
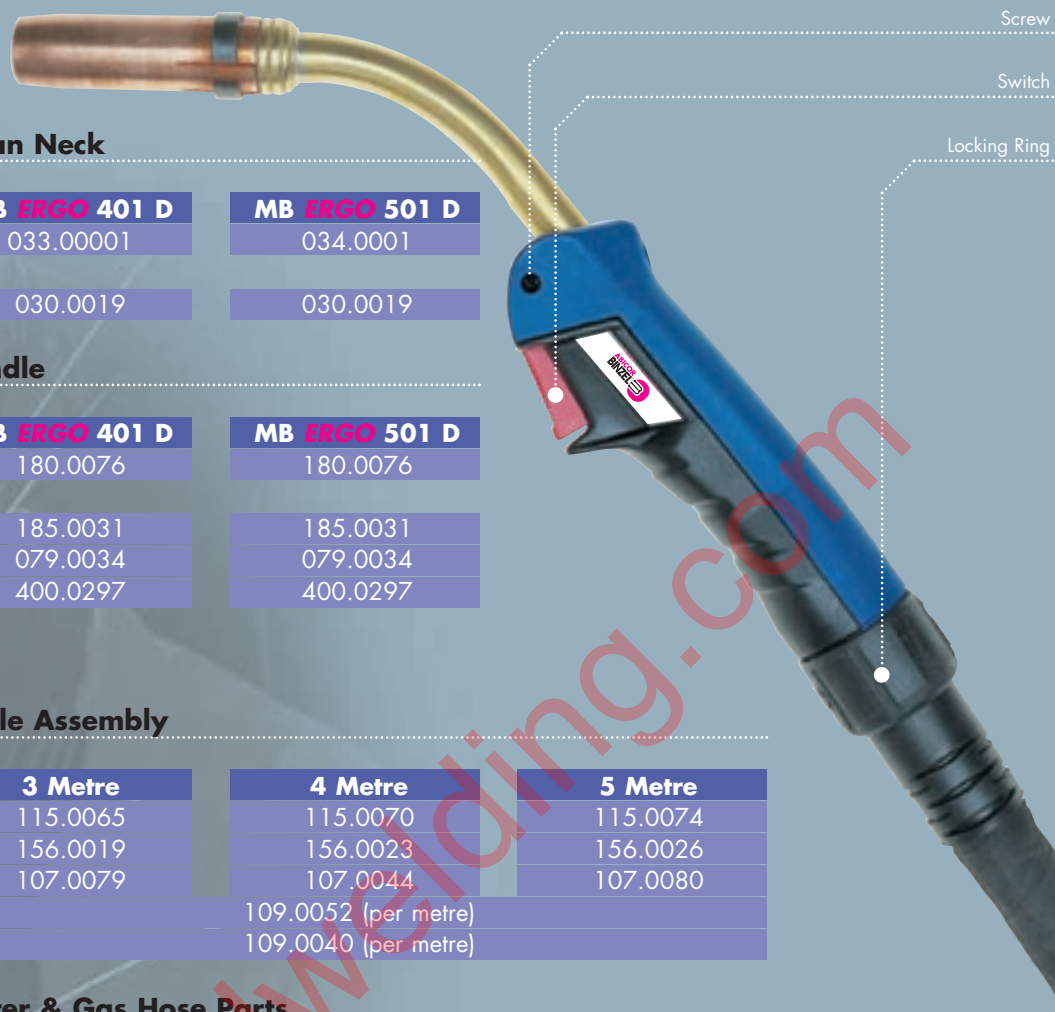

Technology & Quality.

MB **ERGO** MIG/MAG Welding Torches Worldwide recognised.

- The Ergonomic handle – positive handling even in extreme circumstances.
- Air cooled up to 270 A.
- Liquid cooled up to 500 A.
- Optimum cooling of the torch – extending torch life.
- Time-saving torch change-over due to the ABICOR BINZEL central connector.
- Ergonomically and technically mature and reliable.
- Leading quality recognised worldwide.

Introducing the rest of the **ERGO** range...



1. MB **ERGO** 25 AK
Air Cooled
2. MB **ERGO** 36 KD
Air Cooled
3. MB **ERGO** 36 KD
Air Cooled
4. MB **ERGO** 36 KD
'Compact'
Air Cooled

Technology for the welder's world.

**ABICOR
BINZEL**

ERGOLINE

Alexander Binzel UK Ltd, Binzel House, Mill Lane, Winwick Quay, Warrington, Cheshire. WA2 8UA.
Tel : (01925) 653944 Fax : (01925) 654861 e-mail : info@binzelabikor.com website : www.binzelabikor.com

IBG
GROUP

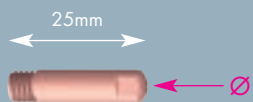

M6 Contact Tips

Pack Size = 50

| Diameter | Standard (E-Cu) | Heavy Duty (CuCrZr) | Aluminium | ABITIP® plus |
|----------|-----------------|---------------------|-----------|--------------|
| Ø 0.6 mm | 140.0008 | - | - | - |
| Ø 0.8 mm | 140.0059 | 140.0062 | 141.0002 | - |
| Ø 0.9 mm | 140.0177 | - | 141.0005 | - |
| Ø 1.0 mm | 140.0253 | 140.0256 | 141.0007 | - |
| Ø 1.2 mm | 140.0387 | 140.0390 | 141.0011 | - |
| Ø 1.4 mm | 140.0522 | - | - | - |
| Ø 1.6 mm | 140.0562 | 140.0563 | - | - |

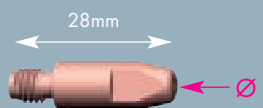

M6 Contact Tips

Pack Size = 50 (ABITIP® plus = 10)

| Diameter | Standard (E-Cu) | Heavy Duty (CuCrZr) | Aluminium | ABITIP® plus |
|----------|-----------------|---------------------|-----------|--------------|
| Ø 0.6 mm | 140.0005 | 140.0998 | - | - |
| Ø 0.8 mm | 140.0051 | 140.0054 | 141.0001 | 144.0054 |
| Ø 0.9 mm | 140.0169 | 140.0172 | 141.0004 | 144.0172 |
| Ø 1.0 mm | 140.0242 | 140.0245 | 141.0006 | 144.0245 |
| Ø 1.2 mm | 140.0379 | 140.0382 | 141.0010 | 144.0382 |
| Ø 1.4 mm | 140.0516 | 140.0519 | 141.0019 | 144.0519 |
| Ø 1.6 mm | 140.0555 | 140.0558 | 141.0020 | 144.0558 |

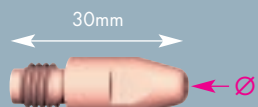

M8 Contact Tips

Pack Size = 50 (ABITIP® plus = 10)

| Diameter | Standard (E-Cu) | Heavy Duty (CuCrZr) | Aluminium | ABITIP® plus |
|----------|-----------------|---------------------|-----------|--------------|
| Ø 0.6 mm | 140.0028 | - | - | - |
| Ø 0.8 mm | 140.0114 | 140.0117 | 141.0003 | 144.0117 |
| Ø 0.9 mm | 140.0214 | 140.0217 | - | 144.0217 |
| Ø 1.0 mm | 140.0313 | 140.0316 | 141.0008 | 144.0316 |
| Ø 1.2 mm | 140.0442 | 140.0445 | 141.0015 | 144.0445 |
| Ø 1.4 mm | 140.0533 | 140.0536 | 141.0055 | 144.0536 |
| Ø 1.6 mm | 140.0587 | 140.0590 | 141.0022 | 144.0590 |
| Ø 2.4 mm | 140.0677 | 140.0679 | 141.0035 | 144.0679 |
| Ø 3.2 mm | - | 140.0719 | - | - |

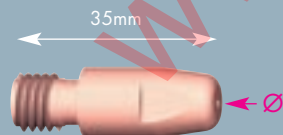

M10 Contact Tips

Pack Size = 50 (ABITIP® = 10)

| Diameter | Standard (E-Cu) | Heavy Duty (CuCrZr) | Aluminium | ABITIP® |
|----------|-----------------|---------------------|-----------|----------|
| Ø 1.0 mm | - | 140.0348 | - | 147.0348 |
| Ø 1.2 mm | - | 140.0481 | - | 147.0481 |
| Ø 1.4 mm | - | 140.0547 | - | 147.0547 |
| Ø 1.6 mm | - | 140.0616 | - | 147.0616 |
| Ø 2.4 mm | - | 140.0698 | - | 147.0698 |
| Ø 3.2 mm | - | 140.0734 | - | 147.0734 |

Air Cooled

MB EVO MIG/MAG Welding Torches

EVO LINE



MB EVO 15 AK

Technical Data (EN 60 974-7)

| Rating | Duty Cycle | Wire Size |
|-----------------------|------------|--------------|
| 180 A CO ² | 60% | 0.6 - 1.2 mm |
| 150 A Mixed Gas | | |



Ball jointed cable assembly, wide excursion range.



MB EVO 'GRIP' handle, moulded 2K material.

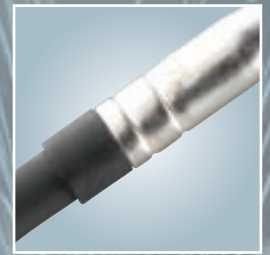

Same consumables as industry standard MB ERGO range.

+ Special length manual & automatic torches are available on request.

Manual Torches

| Torch | 3 Metre | 4 Metre | 5 Metre |
|---------------------|----------|----------|----------|
| MB EVO 15 AK | 002.0604 | 002.0605 | 002.0606 |

+ When ordering complete automatic torches, please indicate torch type, neck angle and length.

Automatic Torches

| Torch | 3 Metre |
|------------------------|----------|
| AUT 15 AK / Str | 902.0022 |
| AUT 15 AK / 45° | 902.0023 |

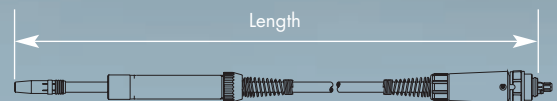

Technology for the welder's world.



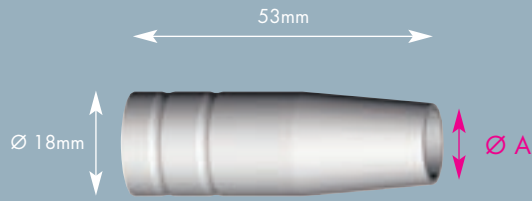

Gas Nozzles

Pack Size = 10

| Ø A | Type | Part Number |
|---------|--------------------|-------------|
| Ø 16mm | Cylindrical | 145.0041 |
| Ø 12mm | Conical | 145.0075 |
| Ø 9.5mm | Tapered | 145.0123 |

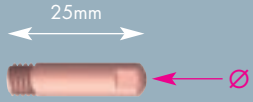

M6 Contact Tips

Pack Size = 50



A full range of our **M6** contact tips is available.

| Diameter | Standard (E-Cu) | Heavy Duty (CuCrZr) | Aluminium |
|----------|-----------------|---------------------|-----------|
| Ø 0.6 mm | 140.0008 | - | - |
| Ø 0.8 mm | 140.0059 | 140.0062 | 141.0002 |
| Ø 1.0 mm | 140.0253 | 140.0256 | 141.0007 |
| Ø 1.2 mm | 140.0387 | 140.0390 | 141.0011 |

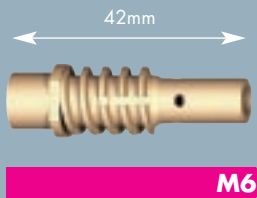

Nozzle Holder

Pack Size = 2



Nozzle Spring

Pack Size = 10

| | Std | Std |
|-----------|----------|----------|
| M6 | 002.0078 | 002.0058 |



PVC Coated Liners

Protects against gas leakage through liner wall

| Colour | Diameter Ø | 3 Metre | 4 Metre | 5 Metre | 50 Metre Coil |
|--------|---------------------|----------|----------|----------|---------------|
| Blue | 0.6 - 0.8 mm | 124.0011 | 124.0012 | 124.0015 | 123.0004 |
| Orange | 1.0 - 1.2 mm | 124.0026 | 124.0031 | 124.0035 | 123.0010 |



PTFE Liners

To be used for Aluminium welding

| Colour | Diameter Ø | 3 Metre | 4 Metre | 5 Metre | 50 Metre Coil |
|--------|---------------------|----------|----------|----------|---------------|
| Blue | 0.6 - 0.8 mm | 126.0005 | 126.0008 | 126.0011 | 125.0004 |
| Orange | 1.0 - 1.2 mm | 126.0021 | 126.0026 | 126.0028 | 125.0006 |

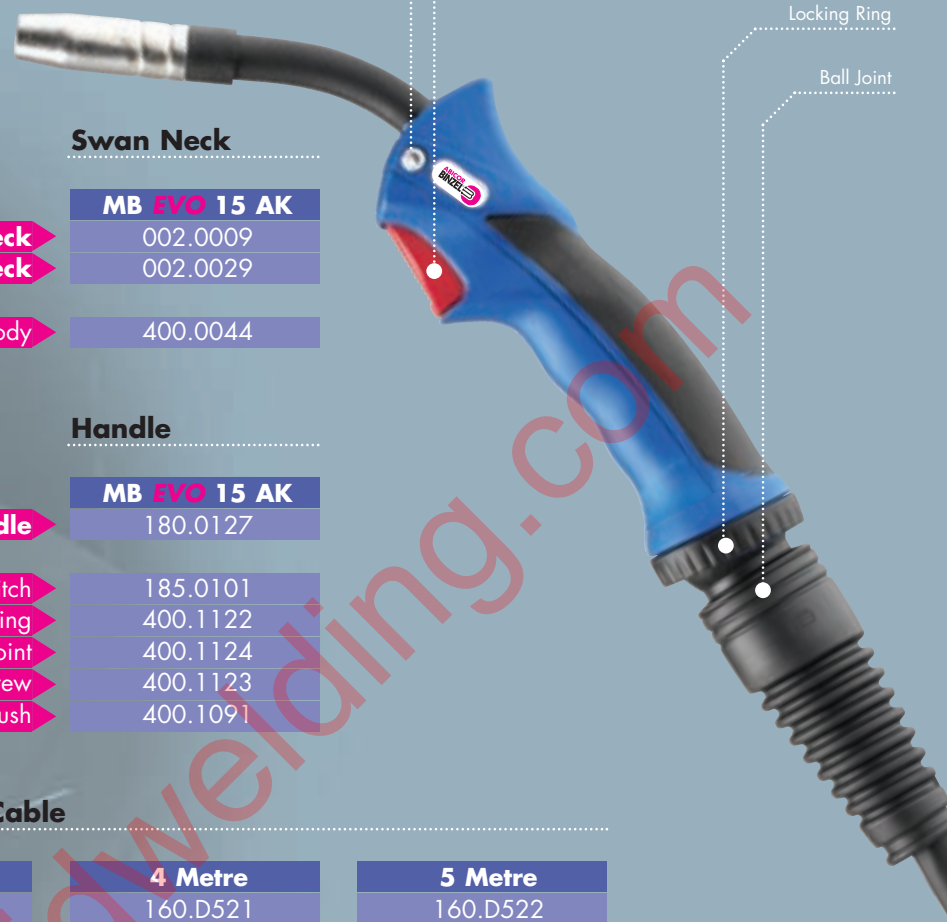

Swan Neck

| MB EVO 15 AK | |
|---------------------|----------|
| 50° Swan Neck | 002.0009 |
| Flexible Swan Neck | 002.0029 |
| Torch Body | 400.0044 |

Handle

| MB EVO 15 AK | |
|---------------------|----------|
| Complete Handle | 180.0127 |
| Switch | 185.0101 |
| Locking Ring | 400.1122 |
| Ball Joint | 400.1124 |
| Screw | 400.1123 |
| Insert Bush | 400.1091 |

Bikox® Power Cable

| Power Cable | 3 Metre | 4 Metre | 5 Metre |
|-------------|----------|----------|----------|
| | 160.D520 | 160.D521 | 160.D522 |

Gun Plug Assembly

| MB EVO 15 AK | |
|---------------------|----------|
| Gun Plug Body | 501.0003 |
| Liner Nut | 501.0082 |
| Spring Pins | 501.2378 |
| Locking Nut | 500.0127 |
| Black Housing | 501.2454 |
| Locking Ring | 400.0987 |
| Cable Support | 400.1010 |

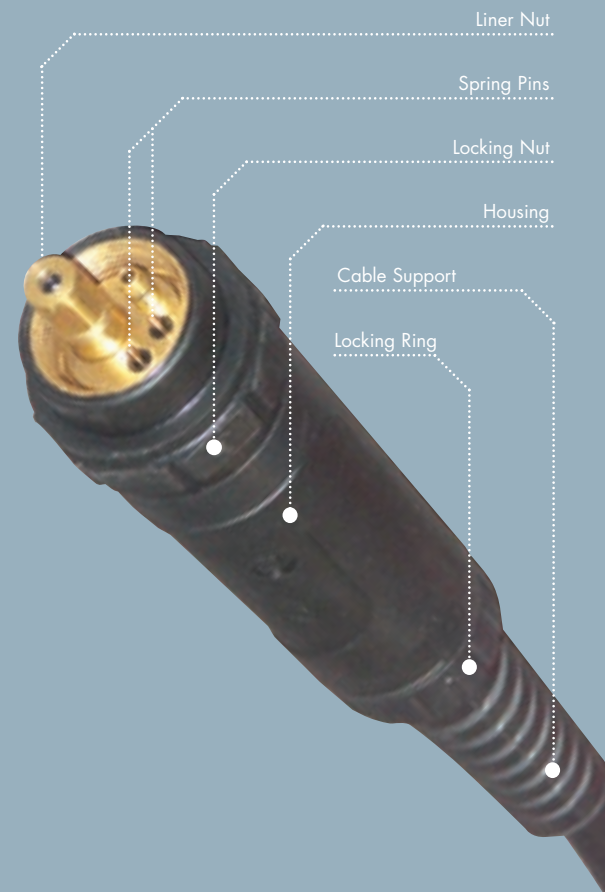

+ The consumables for the automatic torches are the same as the manual torches.

Automatic Version

| AUT 15 AK | |
|---------------|----------|
| Straight Neck | 902.0003 |
| 45° Neck | 902.0004 |
| Handle | 180.0097 |
| Locking Ring | 400.0137 |



The Ergo Has Evolved.

MB **EVO** MIG/MAG Welding Torches Excellent Ergonomics & Flexibility!

- The Ergonomic handle with 'GRIP' – positive handling even in extreme circumstances.
- Ball joint for air and liquid cooled torches – optimal handling.
- Air cooled up to 320 A.
- Liquid cooled up to 500 A.
- Optimum cooling of the torch – extending torch life.
- BIKOX® R air cooled torches – high flexibility even at low temperatures, extremely UV-resistant, considerably increased temperature stability and tensile strength.
- Time-saving torch change-over due to the ABICOR BINZEL central connector.
- Ergonomically and technically mature and reliable.
- Leading quality recognised worldwide.

Introducing the rest of the **EVO** range...



1. **MB EVO 25 AK**
Air Cooled
2. **MB EVO 36 KD**
Air Cooled
3. **MB EVO 401 D**
Liquid Cooled
4. **MB EVO 501 D**
Liquid Cooled

Technology for the welder's world.



EVO LINE

Alexander Binzel UK Ltd, Binzel House, Mill Lane, Winwick Quay, Warrington, Cheshire, WA2 8UA.
Tel : (01925) 653944 Fax : (01925) 654861 e-mail : info@binzelabikor.com website : www.binzelabikor.com

IBG
GROUP

Air Cooled

MB EVO MIG/MAG Welding Torches

EVO LINE



MB EVO 25 AK

Technical Data (EN 60 974-7)

| Rating | Duty Cycle | Wire Size |
|-----------------------|------------|--------------|
| 230 A CO ² | 60% | 0.8 - 1.2 mm |
| 200 A Mixed Gas | | |



Ball jointed cable assembly, wide excursion range.



MB EVO 'GRIP' handle, moulded 2K material.

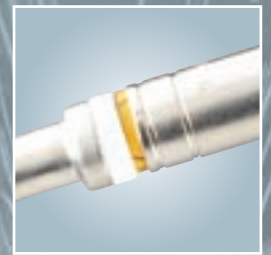

Same consumables as industry standard MB ERGO range.

+ Special length manual & automatic torches are available on request.

Manual Torches

| Torch | 3 Metre | 4 Metre | 5 Metre |
|---------------------|----------|----------|----------|
| MB EVO 25 AK | 004.0510 | 004.0511 | 004.0512 |

+ When ordering complete automatic torches, please indicate **torch type**, **neck angle** and **length**.

Automatic Torches

| Torch | 3 Metre |
|------------------------|----------|
| AUT 25 AK / Str | 904.0003 |
| AUT 25 AK / 45° | 904.0004 |

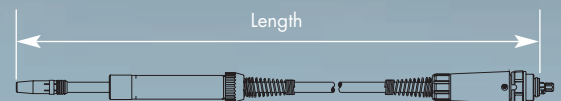

Technology for the welder's world.



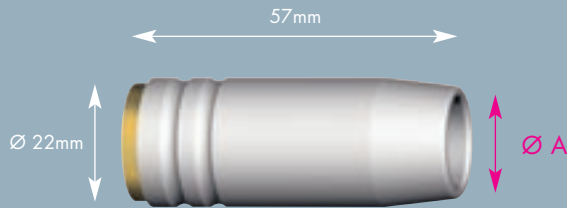

Gas Nozzles

Pack Size = 10

| Ø A | Type | Part Number |
|----------|--------------------|-------------|
| Ø 18mm | Cylindrical | 145.0042 |
| Ø 15mm | Conical | 145.0076 |
| Ø 11.5mm | Tapered | 145.0124 |

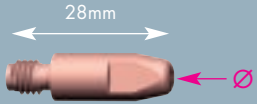

M6 Contact Tips

Pack Size = 50 (ABITIP® plus = 10)



A full range of our **M6** contact tips is available.

| Diameter | Standard (E-Cu) | Heavy Duty (CuCrZr) | Aluminium | ABITIP® plus |
|----------|-----------------|---------------------|-----------|--------------|
| Ø 0.8 mm | 140.0051 | 140.0054 | 141.0001 | 144.0054 |
| Ø 1.0 mm | 140.0242 | 140.0245 | 141.0006 | 144.0245 |
| Ø 1.2 mm | 140.0379 | 140.0382 | 141.0010 | 144.0382 |

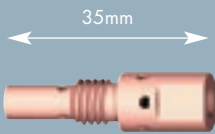

Tip Holder

Pack Size = 10

- M6**
- M8**

| Std |
|----------|
| 142.0001 |
| 142.0015 |



Nozzle Spring

Pack Size = 10

| Std |
|----------|
| 003.0013 |



PVC Coated Liners

Protects against gas leakage through liner wall

| Colour | Diameter Ø | 3 Metre | 4 Metre | 5 Metre | 50 Metre Coil |
|--------|---------------------|----------|----------|----------|---------------|
| Blue | 0.6 - 0.8 mm | 124.0011 | 124.0012 | 124.0015 | 123.0004 |
| Orange | 1.0 - 1.2 mm | 124.0026 | 124.0031 | 124.0035 | 123.0010 |



PTFE Liners

To be used for Aluminium welding

| Colour | Diameter Ø | 3 Metre | 4 Metre | 5 Metre | 50 Metre Coil |
|--------|---------------------|----------|----------|----------|---------------|
| Blue | 0.6 - 0.8 mm | 126.0005 | 126.0008 | 126.0011 | 125.0004 |
| Orange | 1.0 - 1.2 mm | 126.0021 | 126.0026 | 126.0028 | 125.0006 |

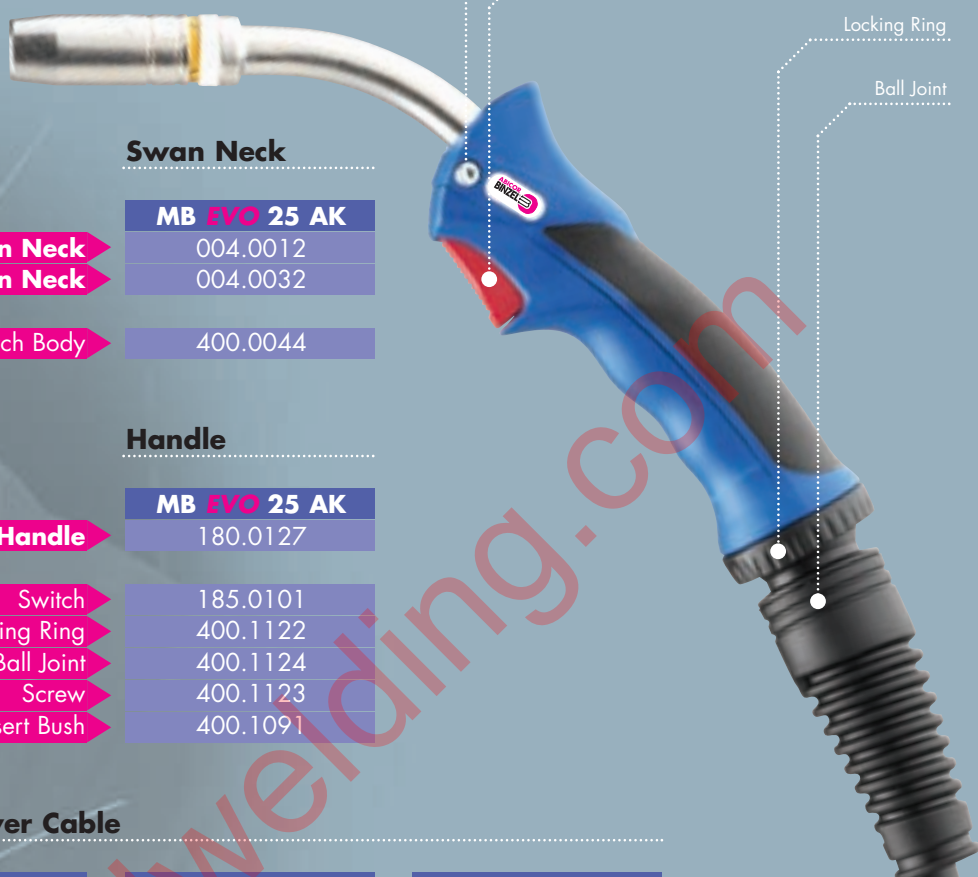

Screw & Insert Bush
Switch
Locking Ring
Ball Joint

Swan Neck

| MB EVO 25 AK | |
|---------------------|----------|
| 50° Swan Neck | 004.0012 |
| Flexible Swan Neck | 004.0032 |
| Torch Body | 400.0044 |

Handle

| MB EVO 25 AK | |
|---------------------|----------|
| Complete Handle | 180.0127 |
| Switch | 185.0101 |
| Locking Ring | 400.1122 |
| Ball Joint | 400.1124 |
| Screw | 400.1123 |
| Insert Bush | 400.1091 |

Bikox® Power Cable

| Power Cable | 3 Metre | 4 Metre | 5 Metre |
|-------------|----------|----------|----------|
| | 160.D427 | 160.D428 | 160.D429 |

Central Adaptor

| MB EVO 25 AK | |
|---------------------|----------|
| Central Adaptor | 501.0003 |
| Liner Nut | 501.0082 |
| Spring Pins | 501.2378 |
| Locking Nut | 500.0213 |
| Black Housing | 501.2454 |
| Locking Ring | 400.0987 |
| Cable Support | 400.1010 |

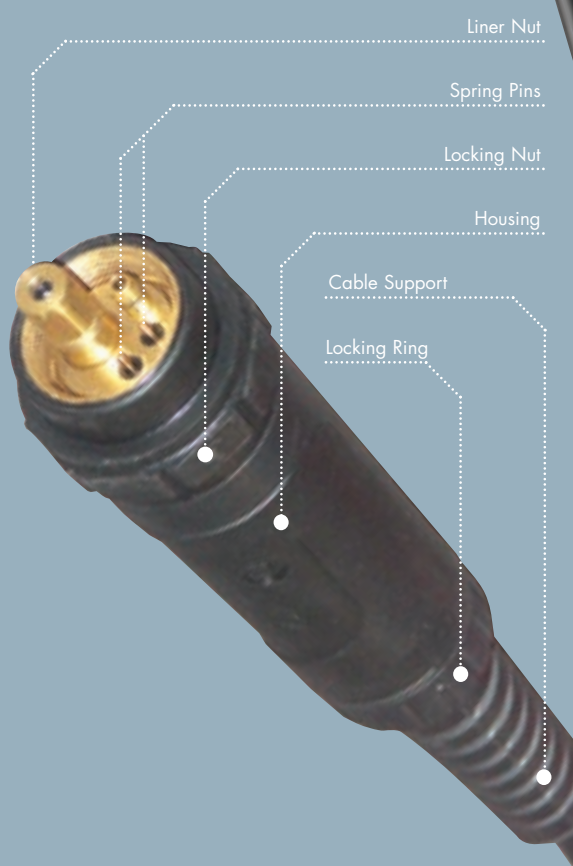

Liner Nut
Spring Pins
Locking Nut
Housing
Cable Support
Locking Ring

+ The consumables for the automatic torches are the same as the manual torches.

Automatic Version

| AUT 25 AK | |
|---------------|----------|
| Straight Neck | 904.0003 |
| 45° Neck | 904.0004 |
| Handle | 180.0097 |
| Locking Ring | 400.0137 |



The Ergo Has Evolved.

MB **EVO** MIG/MAG Welding Torches Excellent Ergonomics & Flexibility!

- The Ergonomic handle with 'GRIP' – positive handling even in extreme circumstances.
- Ball joint for air and liquid cooled torches – optimal handling.
- Air cooled up to 320 A.
- Liquid cooled up to 500 A.
- Optimum cooling of the torch – extending torch life.
- BIKOX® R air cooled torches – high flexibility even at low temperatures, extremely UV-resistant, considerably increased temperature stability and tensile strength.
- Time-saving torch change-over due to the ABICOR BINZEL central connector.
- Ergonomically and technically mature and reliable.
- Leading quality recognised worldwide.

Introducing the rest of the **EVO** range...



1. **MB EVO 15 AK**
Air Cooled
2. **MB EVO 36 KD**
Air Cooled
3. **MB EVO 401 D**
Liquid Cooled
4. **MB EVO 501 D**
Liquid Cooled

EVO LINE

Alexander Binzel UK Ltd, Binzel House, Mill Lane, Winwick Quay, Warrington, Cheshire, WA2 8UA.
Tel : (01925) 653944 Fax : (01925) 654861 e-mail : info@binzelabikor.com website : www.binzelabikor.com

IBG
GROUP

ABICOR
BINZEL

Technology for the welder's world.

Air Cooled

MB EVO MIG/MAG Welding Torches

EVO LINE



MB EVO 36 KD

Technical Data (EN 60 974-7)

| Rating | Duty Cycle | Wire Size |
|------------------------------------------|------------|--------------|
| 320 A CO ² 290 A Mixed Gas | 60% | 0.8 - 1.2 mm |



Ball jointed cable assembly, wide excursion range.



MB EVO 'GRIP' handle, moulded 2K material.



Same consumables as industry standard MB ERGO range.

+ **Special length** manual & automatic torches are available on request.

Manual Torches

| Torch | 3 Metre | 4 Metre | 5 Metre |
|---------------------|----------|----------|----------|
| MB EVO 36 KD | 014.0334 | 014.0335 | 014.0336 |

+ When ordering complete automatic torches, please indicate **torch type**, **neck angle** and **length**.

Automatic Torches

| Torch | 3 Metre |
|------------------------|----------|
| AUT 36 KD / Str | 914.0013 |
| AUT 36 KD / 45° | 914.0014 |

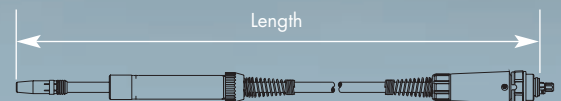

Technology for the welder's world.



Gas Nozzles

Pack Size = 10



| Ø A | Type |
|--------|--------------------|
| Ø 19mm | Cylindrical |
| Ø 16mm | Conical |
| Ø 12mm | Tapered |

| Part Number |
|-------------|
| 145.0045 |
| 145.0078 |
| 145.0126 |

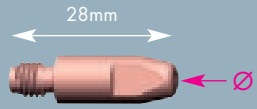

M6 Contact Tips

Pack Size = 50 (ABITIP® plus = 10)

+ A full range of our **M6** contact tips is available.

| Diameter |
|----------|
| Ø 0.8 mm |
| Ø 1.0 mm |
| Ø 1.2 mm |

| Standard (E-Cu) |
|-----------------|
| 140.0051 |
| 140.0242 |
| 140.0379 |

| Heavy Duty (CuCrZr) |
|---------------------|
| 140.0054 |
| 140.0245 |
| 140.0382 |

| Aluminium |
|-----------|
| 141.0001 |
| 141.0006 |
| 141.0010 |

| ABITIP® plus |
|--------------|
| 144.0054 |
| 144.0245 |
| 144.0382 |

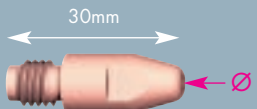

M8 Contact Tips

Pack Size = 50 (ABITIP® plus = 10)

+ A full range of our **M8** contact tips is available.

| Diameter |
|----------|
| Ø 0.8 mm |
| Ø 1.0 mm |
| Ø 1.2 mm |

| Standard (E-Cu) |
|-----------------|
| 140.0114 |
| 140.0313 |
| 140.0442 |

| Heavy Duty (CuCrZr) |
|---------------------|
| 140.0117 |
| 140.0316 |
| 140.0445 |

| Aluminium |
|-----------|
| 141.0003 |
| 141.0008 |
| 141.0015 |

| ABITIP® plus |
|--------------|
| 144.0117 |
| 144.0316 |
| 144.0445 |

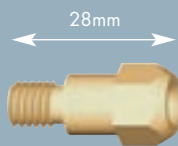

Std Tip Adaptor

Pack Size = 10

| |
|-----------|
| M6 |
| M8 |

| Std |
|----------|
| 142.0005 |
| 142.0020 |

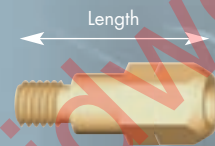

Long Tip Adaptor

Pack Size = 10

| |
|-----------|
| M6 |
| M8 |

| Long |
|----------|
| 142.0011 |
| 142.0024 |

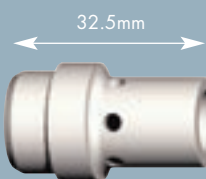

Gas Diffusor

Pack Size = 10

| |
|-----------------|
| Standard |
| Ceramic |

| Part Number |
|-------------|
| 014.0261 |
| 014.0023 |

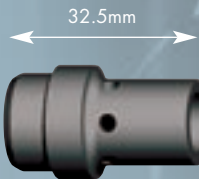

HD Gas Diffusor

Pack Size = 10

| |
|-------------------|
| Heavy Duty |
|-------------------|

| Part Number |
|-------------|
| 014.0026 |

PVC Coated Liners

Protect against gas leakage through liner wall



| Colour | Diameter Ø |
|--------------------------------------------------|------------|
| ■ 0.6 - 0.8 mm | |
| ■ 1.0 - 1.2 mm | |

| 3 Metre |
|----------|
| 124.0011 |
| 124.0026 |

| 4 Metre |
|----------|
| 124.0012 |
| 124.0031 |

| 5 Metre |
|----------|
| 124.0015 |
| 124.0035 |

| 50 Metre Coil |
|---------------|
| 123.0004 |
| 123.0010 |

PTFE Liners

To be used for Aluminium welding



| Colour | Diameter Ø |
|--------------------------------------------------|------------|
| ■ 0.6 - 0.8 mm | |
| ■ 1.0 - 1.2 mm | |

| 3 Metre |
|----------|
| 126.0005 |
| 126.0021 |

| 4 Metre |
|----------|
| 126.0008 |
| 126.0026 |

| 5 Metre |
|----------|
| 126.0011 |
| 126.0028 |

| 50 Metre Coil |
|---------------|
| 125.0004 |
| 125.0006 |



Swan Neck

| | |
|----------------------|---------------------------------|
| 50° Swan Neck | MB EVO 36 KD 014.0006 |
|----------------------|---------------------------------|

Handle

| | |
|------------------------|---------------------------------|
| Complete Handle | MB EVO 36 KD 180.0127 |
| Switch | 185.0101 |
| Locking Ring | 400.1122 |
| Ball Joint | 400.1124 |
| Screw | 400.1123 |
| Insert Bush | 400.1091 |

Bikox® Power Cable

| | | | |
|--------------------|----------------------------|----------------------------|----------------------------|
| Power Cable | 3 Metre 160.D434 | 4 Metre 160.D435 | 5 Metre 160.D436 |
|--------------------|----------------------------|----------------------------|----------------------------|

Gun Plug Assembly

| | |
|----------------------|---------------------------------|
| Gun Plug Body | MB EVO 36 KD 501.0003 |
| Liner Nut | 501.0082 |
| Spring Pins | 501.2378 |
| Locking Nut | 500.0213 |
| Black Housing | 501.2454 |
| Locking Ring | 400.0987 |
| Cable Support | 400.1010 |

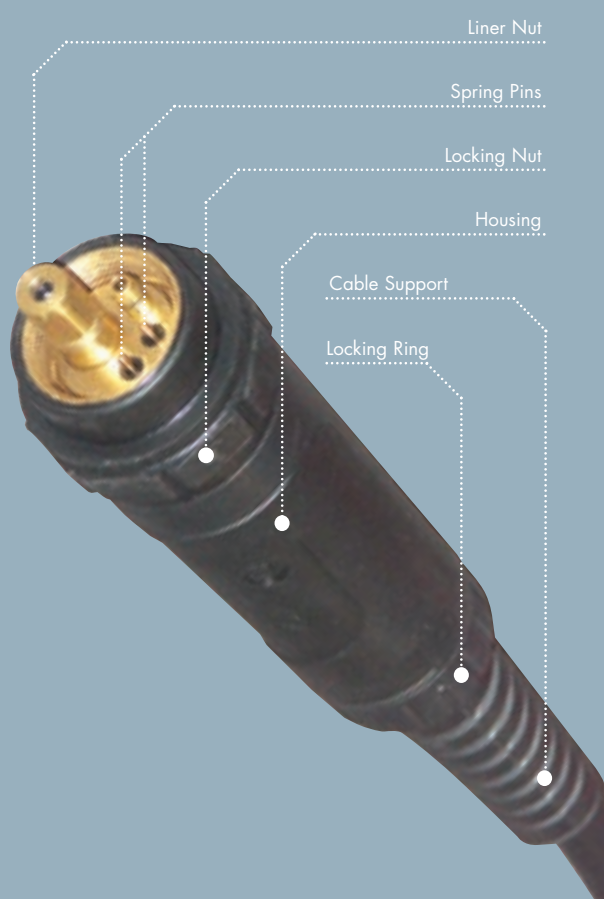

+ The consumables for the automatic torches are the same as the manual torches.

Automatic Version

| | |
|----------------------|------------------|
| Aut 36 KD | AUT 36 KD |
| Straight Neck | 914.0002 |
| 22° Neck | 914.0025 |
| 45° Neck | 914.0001 |
| Handle | 180.0097 |
| Locking Ring | 400.0137 |



The Ergo Has Evolved.

MB **EVO** MIG/MAG Welding Torches Excellent Ergonomics & Flexibility!

- The Ergonomic handle with 'GRIP' – positive handling even in extreme circumstances.
- Ball joint for air and liquid cooled torches – optimal handling.
- Air cooled up to 320 A.
- Liquid cooled up to 500 A.
- Optimum cooling of the torch – extending torch life.
- BIKOX® R air cooled torches – high flexibility even at low temperatures, extremely UV-resistant, considerably increased temperature stability and tensile strength.
- Time-saving torch change-over due to the ABICOR BINZEL central connector.
- Ergonomically and technically mature and reliable.
- Leading quality recognised worldwide.

Introducing the rest of the **EVO** range...



1. MB **EVO** 15 AK
Air Cooled
2. MB **EVO** 25 AK
Air Cooled
3. MB **EVO** 401 D
Liquid Cooled
3. MB **EVO** 501 D
Liquid Cooled

EVO LINE

Alexander Binzel UK Ltd, Binzel House, Mill Lane, Winwick Quay, Warrington, Cheshire, WA2 8UA.
Tel : (01925) 653944 Fax : (01925) 654861 e-mail : info@binzelabikor.com website : www.binzelabikor.com

IBG
GROUP

ABICOR
BINZEL

Technology for the welder's world.

Air Cooled

ABIMIG® MIG/MAG Welding Torches

PRO LINE

+ The swan neck can be rotated in **8 positions**.

ABIMIG® 250 TM

Technical Data (EN 60 974-7)

Rating

250 A CO₂
200 A Mixed Gas

Duty Cycle

60%

Wire Size

0.8 - 1.2 mm



High performance, re-inforced plastic handle.



Rotatable swan neck. Easier access for awkward welding positions.



Unique spares. Insulated and threaded gas nozzle - more secure than push-on.

+ **Special length** manual & automatic torches are available on request.

Manual Torches

Torch

ABIMIG® 250 TM

3 Metre

004.D553RH

4 Metre

004.D554RH

5 Metre

004.D555RH

Technology for the welder's world.



Gas Nozzles

Pack Size = 10

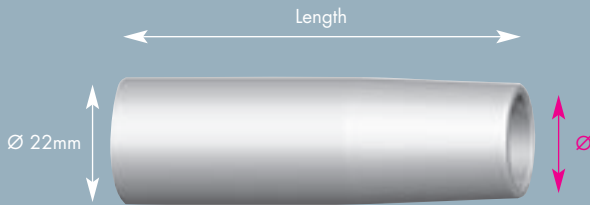

| Ø | Length | Type | Part Number |
|------|--------|-------------|-------------|
| 16mm | 70mm | Conical | 145.D011 |
| 14mm | 67mm | Conical | 145.D012 |
| 18mm | 69mm | Cylindrical | 145.D014 |
| 12mm | 70mm | Tapered | 145.D015 |
| 14mm | 70mm | Conical | 145.D016 |

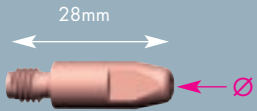

M6 Contact Tips

Pack Size = 50 (ABITIP® plus = 10)



A full range of our M6 contact tips is available.

| Diameter | Standard (E-Cu) | Heavy Duty (CuCrZr) | Aluminium | ABITIP® plus |
|----------|-----------------|---------------------|-----------|--------------|
| Ø 0.8 mm | 140.0051 | 140.0054 | 141.0001 | 144.0054 |
| Ø 1.0 mm | 140.0242 | 140.0245 | 141.0006 | 144.0245 |
| Ø 1.2 mm | 140.0379 | 140.0382 | 141.0010 | 144.0382 |



Neck Liner

Pack Size = 1



Brass Neck Liner

For Aluminium wire.

| Wire Size Ø | Std | Part Number |
|-------------|----------|-------------|
| 0.6 - 1.0mm | 122.D037 | 122.D040 |
| 1.0 - 1.2mm | 122.D038 | 122.D041 |



Tip Holder

Pack Size = 10

| Std |
|----------|
| 004.D624 |



PVC Coated Liners

Protects against gas leakage through liner wall

| Colour | Diameter Ø | 3 Metre | 4 Metre | 5 Metre | 50 Metre Coil |
|--------|--------------|----------|----------|----------|---------------|
| Blue | 0.6 - 0.8 mm | 124.0011 | 124.0012 | 124.0015 | 123.0004 |
| Red | 1.0 - 1.2 mm | 124.0026 | 124.0031 | 124.0035 | 123.0010 |



PTFE Liners

To be used for Aluminium welding

| Colour | Diameter Ø | 3 Metre | 4 Metre | 5 Metre | 50 Metre Coil |
|--------|--------------|----------|----------|----------|---------------|
| Blue | 0.6 - 0.8 mm | 126.0005 | 126.0008 | 126.0011 | 125.0004 |
| Red | 1.0 - 1.2 mm | 126.0021 | 126.0026 | 126.0028 | 125.0006 |

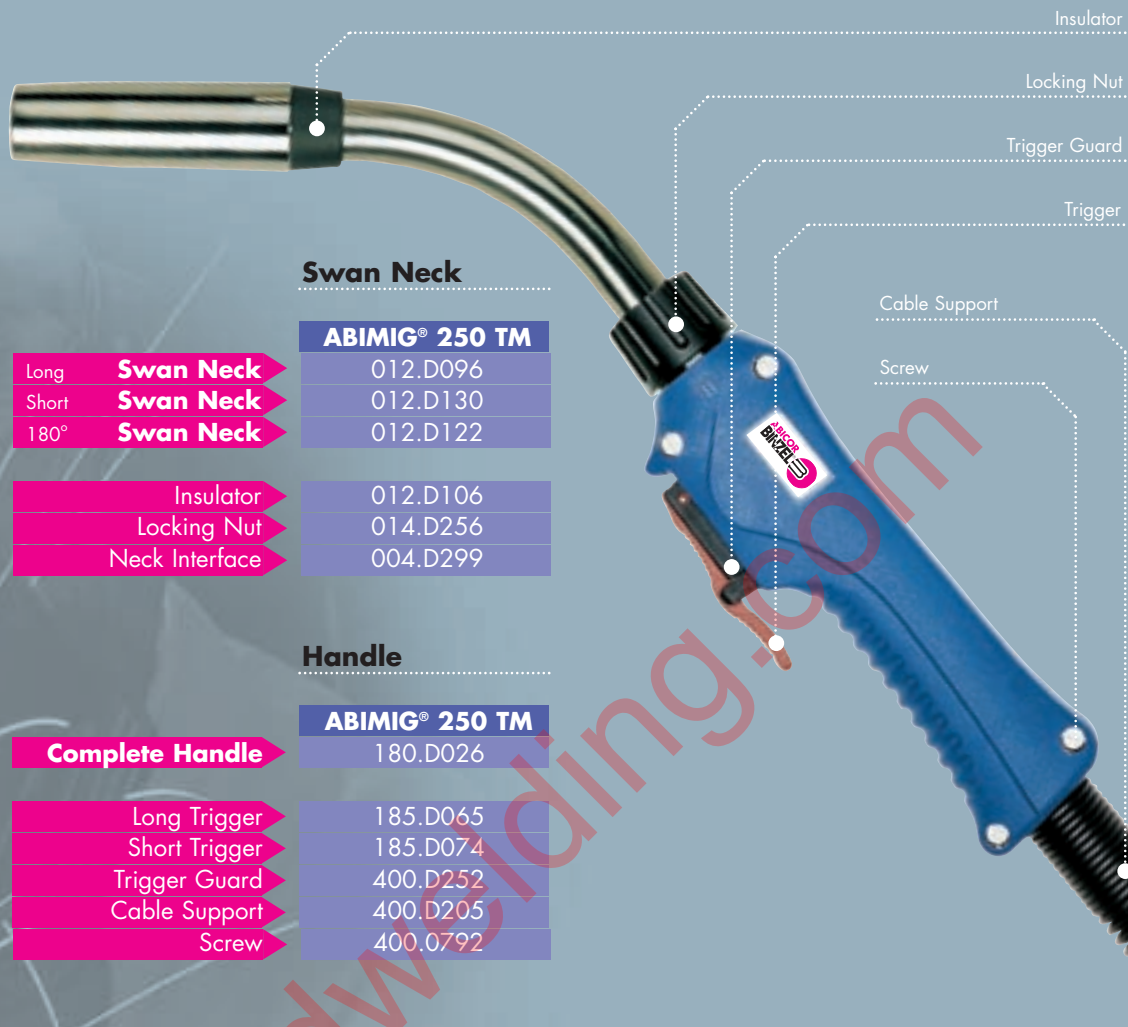

Insulator

Locking Nut

Trigger Guard

Trigger

Cable Support

Screw

Swan Neck

| | ABIMIG® 250 TM |
|-----------------|----------------|
| Long Swan Neck | 012.D096 |
| Short Swan Neck | 012.D130 |
| 180° Swan Neck | 012.D122 |
| Insulator | 012.D106 |
| Locking Nut | 014.D256 |
| Neck Interface | 004.D299 |

Handle

| | ABIMIG® 250 TM |
|-----------------|----------------|
| Complete Handle | 180.D026 |
| Long Trigger | 185.D065 |
| Short Trigger | 185.D074 |
| Trigger Guard | 400.D252 |
| Cable Support | 400.D205 |
| Screw | 400.0792 |

Bikox® Power Cable

| | 3 Metre | 4 Metre | 5 Metre |
|-------------|----------|----------|----------|
| Power Cable | 160.D427 | 160.D428 | 160.D429 |

Gun Plug Assembly

| | ABIMIG® 250TM |
|---------------|---------------|
| Gun Plug Body | 501.0003 |
| Liner Nut | 501.0082 |
| Spring Pins | 501.2378 |
| Locking Nut | 500.0213 |
| Black Housing | 501.2454 |
| Locking Ring | 400.0987 |
| Cable Support | 400.1010 |

Liner Nut

Spring Pins

Locking Nut

Housing

Cable Support

Locking Ring

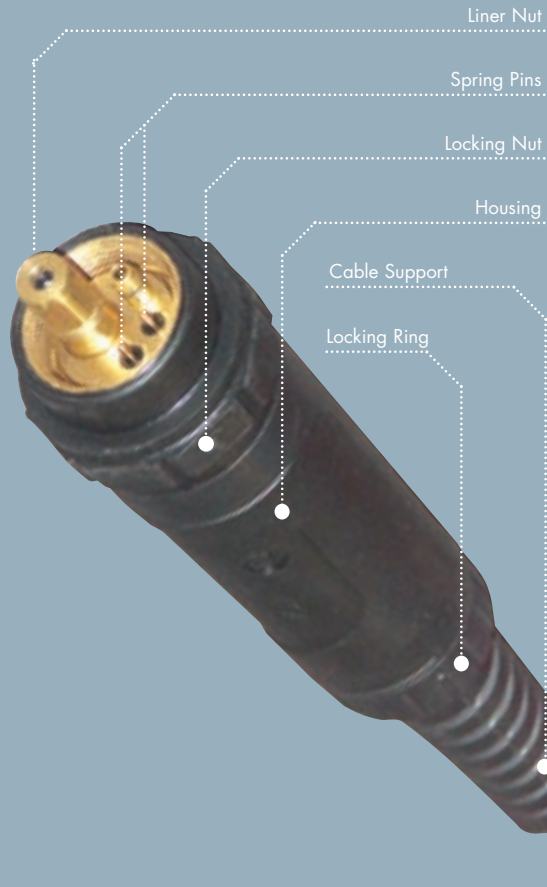

We just want you to be **ABI.**

ABIMIG® TM MIG/MAG Welding Torches High performance, whatever the welding job.

- Air cooled up to 450 A.
- Optimum cooling of the torch – extending torch life.
- BIKOX® R air cooled torches – high flexibility even at low temperatures, extremely UV-resistant, considerably increased temperature stability and tensile strength.
- Time-saving torch change-over due to the ABICOR BINZEL central connector.
- Fast neck change-over reduces down time - extends flexibility.
- Leading quality recognised worldwide.

Introducing the rest of the **ABIMIG® TM** range...



1

2

3

1. **ABIMIG® 350 TM**
Air Cooled
2. **ABIMIG® 400 TM**
Air Cooled
3. **ABIMIG® 450 TM**
Air Cooled

PRO LINE

Alexander Binzel UK Ltd, Binzel House, Mill Lane, Winwick Quay, Warrington, Cheshire, WA2 8UA.
Tel : (01925) 653944 Fax : (01925) 654861 e-mail : info@binzelabikor.com website : www.binzel-abikor.com

IBG
GROUP

Technology for the welder's world.

ABICOR
BINZEL®

Air Cooled

ABIMIG® MIG/MAG Welding Torches

PROLINE

+ The swan neck can be rotated in **8 positions**.

ABIMIG® 350 TM

Technical Data (EN 60 974-7)

Rating

360 A CO₂
320 A Mixed Gas

Duty Cycle

60%

Wire Size

1.0 - 1.6 mm



High performance, re-inforced plastic handle.



Rotatable swan neck. Easier access for awkward welding positions.



Unique spares. Insulated and threaded gas nozzle - more secure than push-on.

+ Special length manual & automatic torches are available on request.

Manual Torches

Torch

ABIMIG® 350 TM

3 Metre

014.D932RH

4 Metre

014.D933RH

5 Metre

014.D934RH

Technology for the welder's world.



Gas Nozzles

Pack Size = 5

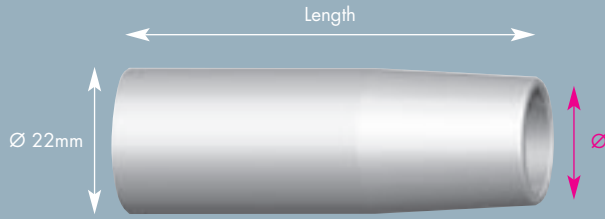

| Ø | Length | Type | Part Number |
|------|--------|-------------|-------------|
| 18mm | 72mm | Conical | 145.D021 |
| 16mm | 72mm | Conical | 145.D026 |
| 21mm | 72mm | Cylindrical | 145.D024 |
| 12mm | 72mm | Tapered | 145.D025 |

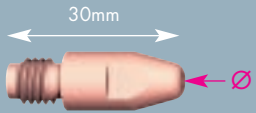

M8 Contact Tips

Pack Size = 50 (ABITIP® plus = 10)

+ A full range of our **M6** contact tips is available.

| Diameter | Standard (E-Cu) | Heavy Duty (CuCrZr) | Aluminium | ABITIP® plus |
|----------|-----------------|---------------------|-----------|--------------|
| Ø 1.0 mm | 140.0313 | 140.0316 | 141.0008 | 144.0316 |
| Ø 1.2 mm | 140.0442 | 140.0445 | 141.0015 | 144.0445 |
| Ø 1.4 mm | 140.0533 | 140.0536 | 141.0055 | 144.0536 |
| Ø 1.6 mm | 140.0587 | 140.0590 | 141.0022 | 144.0590 |



Neck Liner

Pack Size = 1



Brass Neck Liner

For Aluminium wire.

| Wire Size Ø | Part No. | Wire Size Ø | Part Number |
|-------------|----------|-------------|-------------|
| 1.0 - 1.2mm | 122.D038 | 0.6 - 1.0mm | 122.D040 |
| 1.2 - 1.4mm | 122.D039 | 1.0 - 1.4mm | 122.D041 |
| 1.4 - 1.6mm | 122.D045 | | |



Tip / Nozzle Holder

Pack Size = 10

| Part No. |
|----------|
| 014.D745 |

M8



PVC Coated Liners

Protect against gas leakage through liner wall

| Colour | Diameter Ø | 3 Metre | 4 Metre | 5 Metre | 50 Metre Coil |
|--------|--------------|----------|----------|----------|---------------|
| Red | 1.0 - 1.2 mm | 124.0026 | 124.0031 | 124.0035 | 123.0010 |
| Yellow | 1.4 - 1.6 mm | 124.0041 | 124.0042 | 124.0044 | 123.0016 |



PTFE Liners

To be used for Aluminium welding

| Colour | Diameter Ø | 3 Metre | 4 Metre | 5 Metre | 50 Metre Coil |
|--------|--------------|----------|----------|----------|---------------|
| Red | 1.0 - 1.2 mm | 126.0021 | 126.0026 | 126.0028 | 125.0006 |
| Yellow | 1.4 - 1.6 mm | 126.0039 | 126.0042 | 126.0045 | 125.0017 |

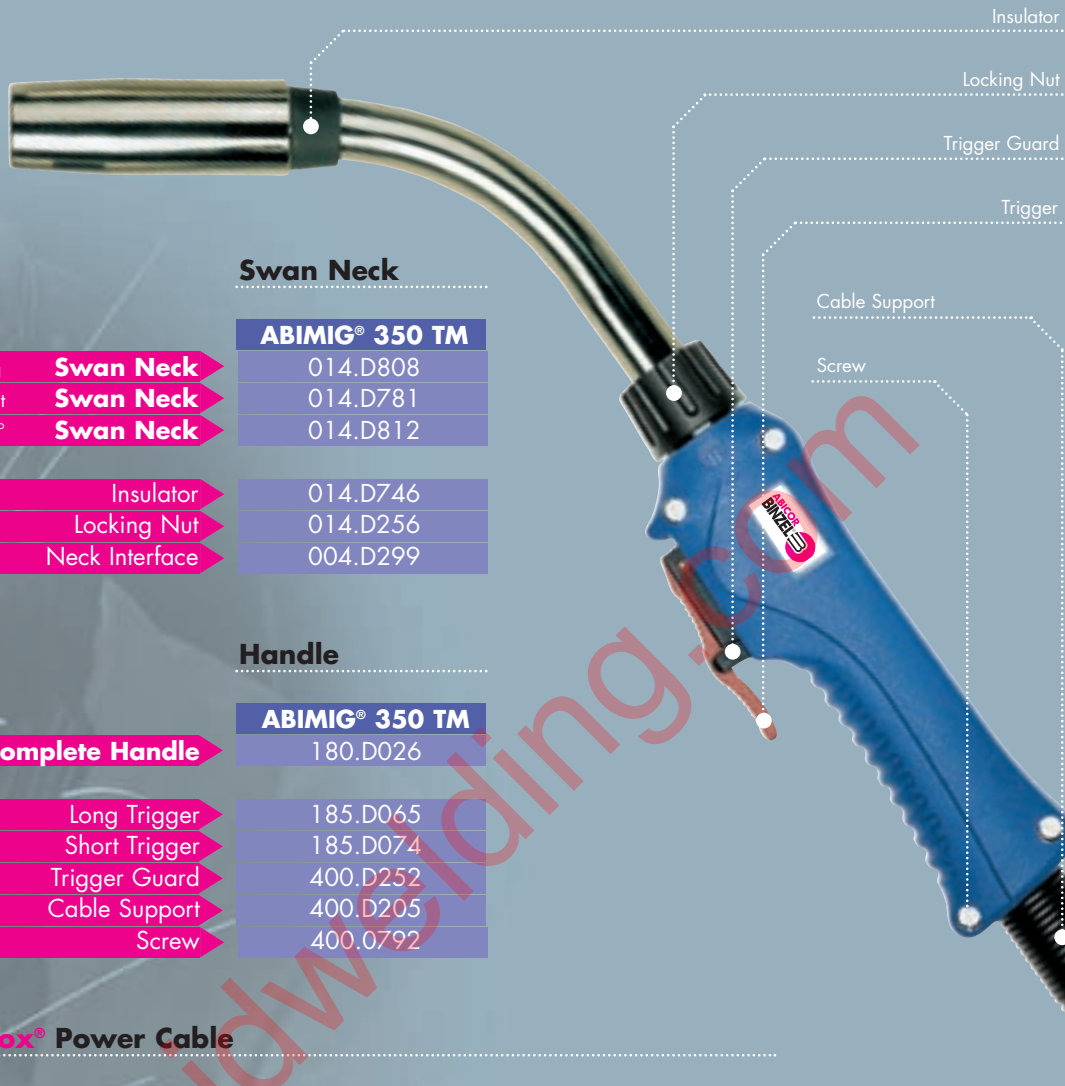

Insulator

Locking Nut

Trigger Guard

Trigger

Cable Support

Screw

Swan Neck

| | ABIMIG® 350 TM |
|-----------------|----------------|
| Long Swan Neck | 014.D808 |
| Short Swan Neck | 014.D781 |
| 180° Swan Neck | 014.D812 |
| Insulator | 014.D746 |
| Locking Nut | 014.D256 |
| Neck Interface | 004.D299 |

Handle

| | ABIMIG® 350 TM |
|-----------------|----------------|
| Complete Handle | 180.D026 |
| Long Trigger | 185.D065 |
| Short Trigger | 185.D074 |
| Trigger Guard | 400.D252 |
| Cable Support | 400.D205 |
| Screw | 400.0792 |

Bikox® Power Cable

| | 3 Metre | 4 Metre | 5 Metre |
|-------------|----------|----------|----------|
| Power Cable | 160.D434 | 160.D435 | 160.D436 |

Gun Plug Assembly

| | ABIMIG® 350 TM |
|---------------|----------------|
| Gun Plug Body | 501.0003 |
| Liner Nut | 501.0082 |
| Spring Pins | 501.2378 |
| Locking Nut | 500.0213 |
| Black Housing | 501.2454 |
| Locking Ring | 400.0987 |
| Cable Support | 400.1010 |

Liner Nut

Spring Pins

Locking Nut

Housing

Cable Support

Locking Ring

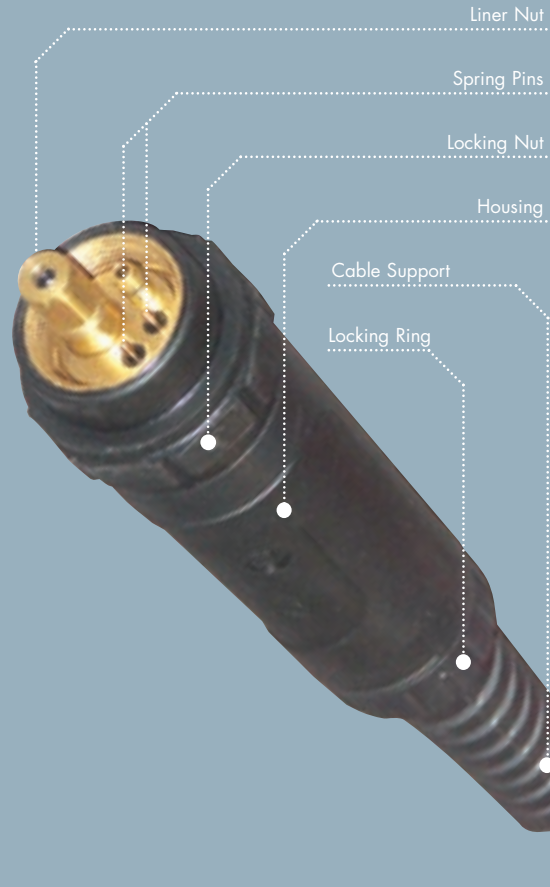

We just want you to be **ABI.**

ABIMIG® TM MIG/MAG Welding Torches High performance, whatever the welding job.

- Air cooled up to 450 A.
- Optimum cooling of the torch – extending torch life.
- BIKOX® R air cooled torches – high flexibility even at low temperatures, extremely UV-resistant, considerably increased temperature stability and tensile strength.
- Time-saving torch change-over due to the ABICOR BINZEL central connector.
- Fast neck change-over reduces down time - extends flexibility.
- Leading quality recognised worldwide.

Introducing the rest of the **ABIMIG® TM** range...



1

2

3

1. **ABIMIG® 250 TM**
Air Cooled
2. **ABIMIG® 400 TM**
Air Cooled
3. **ABIMIG® 450 TM**
Air Cooled

PRO LINE

Alexander Binzel UK Ltd, Binzel House, Mill Lane, Winwick Quay, Warrington, Cheshire, WA2 8UA.
Tel : (01925) 653944 Fax : (01925) 654861 e-mail : info@binzelabikor.com website : www.binzel-abikor.com

IBG
GROUP

ABICOR
BINZEL®

Technology for the welder's world.

Air Cooled

ABIMIG® MIG/MAG Welding Torches

PROLINE

+ The swan neck can be rotated in **8 positions**.

ABIMIG® 400 TM

Technical Data (EN 60 974-7)

| | | |
|---------------------------------------------------|--------------------------|----------------------------------|
| Rating A CO ₂ A Mixed Gas | Duty Cycle 60% | Wire Size 1.0 - 1.6 mm |
|---------------------------------------------------|--------------------------|----------------------------------|

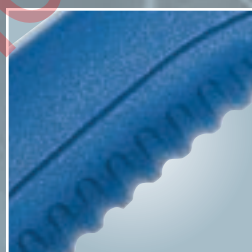

High performance, re-inforced plastic handle.



Rotatable swan neck. Easier access for awkward welding positions.



Unique spares. Insulated and threaded gas nozzle - more secure than push-on.

+ **Special length** manual & automatic torches are available on request.

Manual Torches

| | | | |
|-------|----------------------------|----------------------------|----------------------------|
| Torch | 3 Metre 014.H029 | 4 Metre 014.H030 | 5 Metre 014.H031 |
|-------|----------------------------|----------------------------|----------------------------|

ABIMIG® 400 TM

Technology for the welder's world.



Gas Nozzles

Pack Size = 5

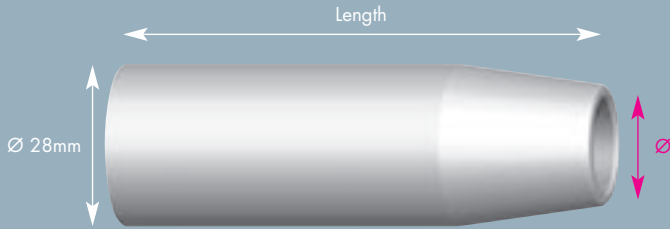

| Ø | Length | Type |
|------|--------|-------------|
| 13mm | 85mm | Conical |
| 16mm | 85mm | Conical |
| 19mm | 85mm | Conical |
| 24mm | 83mm | Cylindrical |

| Part Number |
|-------------|
| 145.D243 |
| 145.D244 |
| 145.D245 |
| 145.D249 |

HD Copper

Gas Nozzles

Pack Size = 5

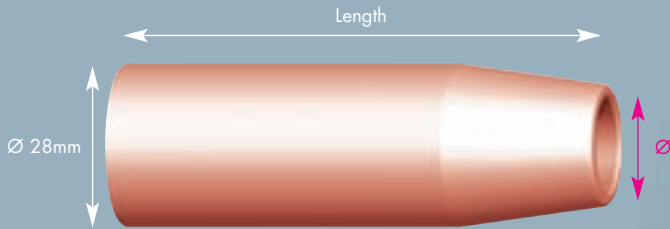

| Ø | Length | Type |
|------|--------|---------|
| 16mm | 85mm | Conical |
| 19mm | 85mm | Conical |

| Part Number |
|-------------|
| 145.D241 |
| 145.D242 |

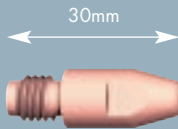

M8 Contact Tips

Pack Size = 50 (ABITIP® plus = 10)

A full range of our M8 contact tips is available.

| Diameter |
|----------|
| Ø 1.0 mm |
| Ø 1.2 mm |
| Ø 1.4 mm |
| Ø 1.6 mm |

| Standard (E-Cu) |
|-----------------|
| 140.0313 |
| 140.0442 |
| 140.0533 |
| 140.0587 |

| Heavy Duty (CuCrZr) |
|---------------------|
| 140.0316 |
| 140.0445 |
| 140.0536 |
| 140.0590 |

| ABITIP® plus |
|--------------|
| 144.0316 |
| 144.0445 |
| 144.0533 |
| 144.0590 |

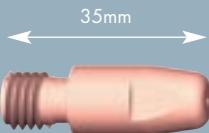

M10 Contact Tips

Pack Size = 50 (ABITIP® = 10)

A full range of our M10 contact tips is available.

| Diameter |
|----------|
| Ø 1.0 mm |
| Ø 1.2 mm |
| Ø 1.4 mm |
| Ø 1.6 mm |

| Standard (E-Cu) |
|-----------------|
| - |
| - |
| - |
| - |

| Heavy Duty (CuCrZr) |
|---------------------|
| 140.0348 |
| 140.0481 |
| 140.0547 |
| 140.0616 |

| ABITIP® |
|----------|
| 147.0348 |
| 147.0481 |
| 147.0547 |
| 147.0616 |



Neck Liner

Pack Size = 1

| Wire Size Ø | Part No. |
|--------------|----------|
| 1.0 - 1.2 mm | 122.D077 |
| 1.4 - 1.6 mm | 122.D078 |

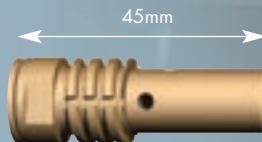

Tip / Nozzle Holder

Pack Size = 10

| Part No. |
|-----------------|
| M8 016.D155 |
| M10 016.D156 |

PVC Coated Liners

Protect against gas leakage through liner wall



| Colour | Diameter Ø |
|--------|--------------|
| ■ | 1.0 - 1.2 mm |
| ■ | 1.4 - 1.6 mm |

| 3 Metre |
|----------|
| 124.D094 |
| 124.D044 |

| 4 Metre |
|----------|
| 124.D095 |
| 124.D044 |

| 5 Metre |
|----------|
| 124.D096 |
| 124.D044 |

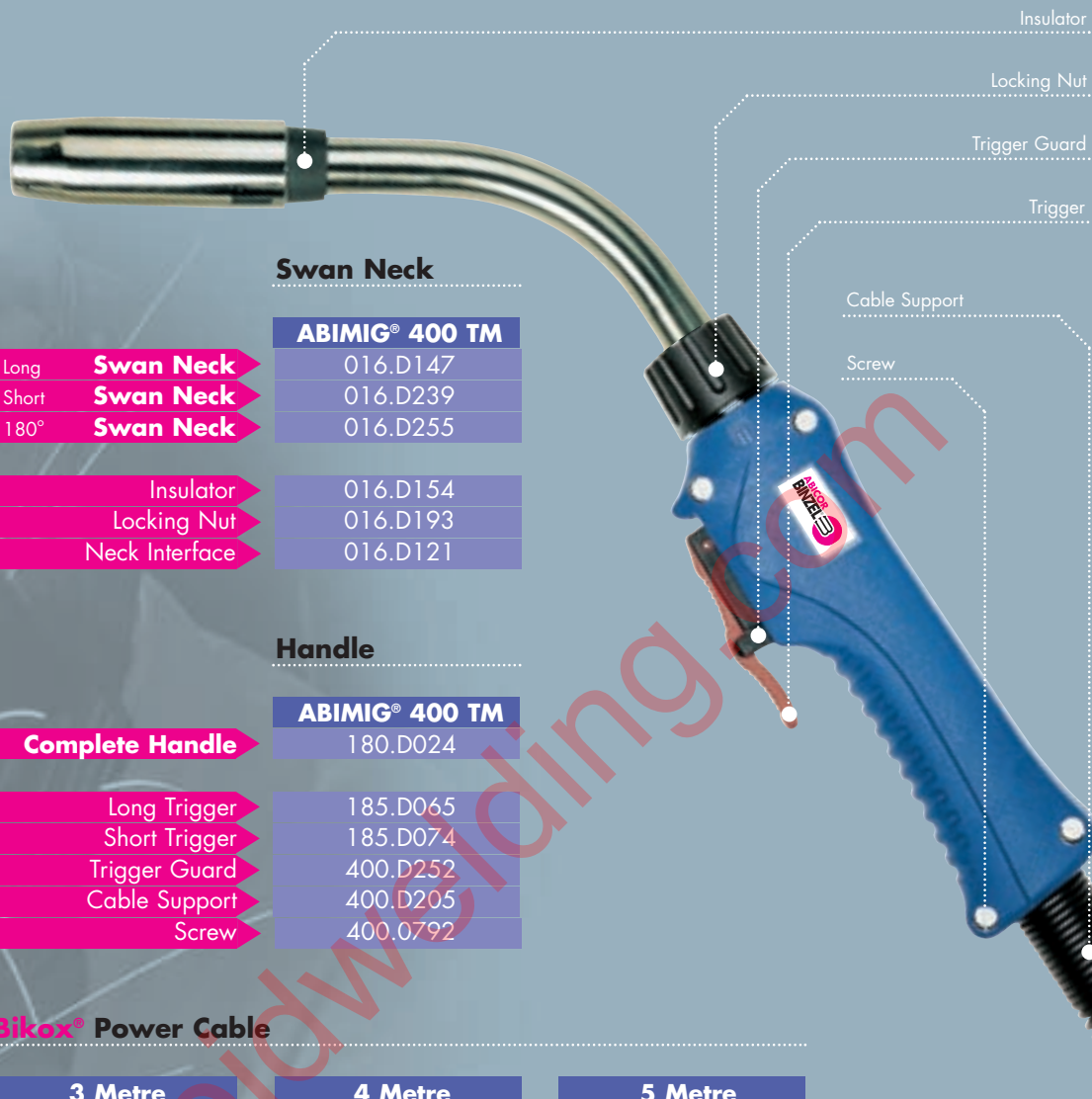

Insulator

Locking Nut

Trigger Guard

Trigger

Cable Support

Screw

Swan Neck

| | ABIMIG® 400 TM |
|-----------------|----------------|
| Long Swan Neck | 016.D147 |
| Short Swan Neck | 016.D239 |
| 180° Swan Neck | 016.D255 |
| Insulator | 016.D154 |
| Locking Nut | 016.D193 |
| Neck Interface | 016.D121 |

Handle

| | ABIMIG® 400 TM |
|-----------------|----------------|
| Complete Handle | 180.D024 |
| Long Trigger | 185.D065 |
| Short Trigger | 185.D074 |
| Trigger Guard | 400.D252 |
| Cable Support | 400.D205 |
| Screw | 400.0792 |

Bikox® Power Cable

| | 3 Metre | 4 Metre | 5 Metre |
|-------------|----------|----------|----------|
| Power Cable | 160.D799 | 160.D800 | 160.D801 |

Gun Plug Assembly

| | ABIMIG® 400 TM |
|---------------|----------------|
| Gun Plug Body | 501.D342 |
| Liner Nut | 500.0129 |
| Spring Pins | 501.2378 |
| Locking Nut | 500.0213 |
| Black Housing | 501.2454 |
| Locking Ring | 400.0987 |
| Cable Support | 400.1010 |

Liner Nut

Spring Pins

Locking Nut

Housing

Cable Support

Locking Ring



We just want you to be **ABI.**

ABIMIG® TM MIG/MAG Welding Torches High performance, whatever the welding job.

- Air cooled up to 450 A.
- Optimum cooling of the torch – extending torch life.
- BIKOX® R air cooled torches – high flexibility even at low temperatures, extremely UV-resistant, considerably increased temperature stability and tensile strength.
- Time-saving torch change-over due to the ABICOR BINZEL central connector.
- Fast neck change-over reduces down time - extends flexibility.
- Leading quality recognised worldwide.

Introducing the rest of the **ABIMIG® TM** range...

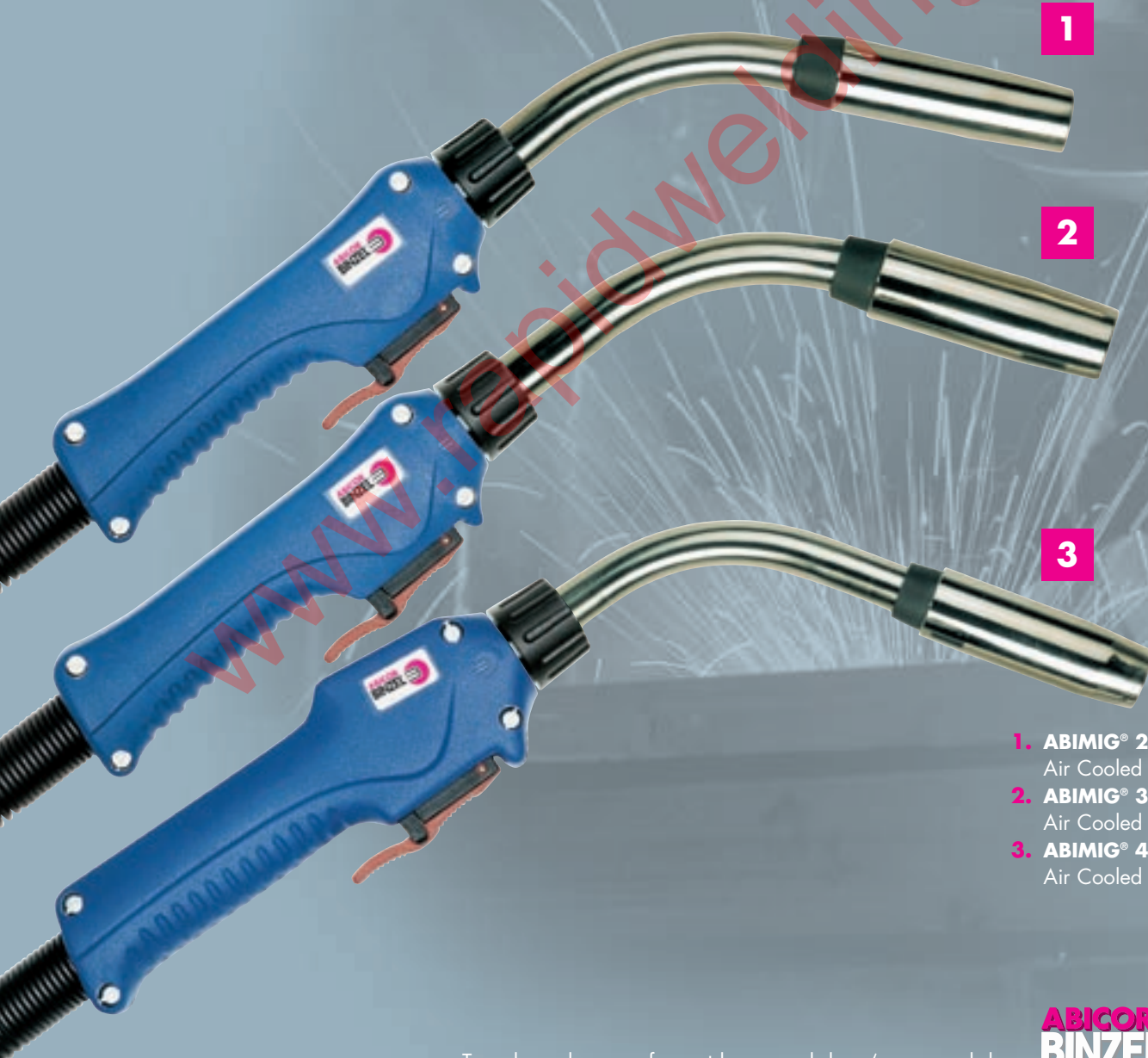

1. **ABIMIG® 250 TM**
Air Cooled
2. **ABIMIG® 350 TM**
Air Cooled
3. **ABIMIG® 450 TM**
Air Cooled

PROLINE

Alexander Binzel UK Ltd, Binzel House, Mill Lane, Winwick Quay, Warrington, Cheshire, WA2 8UA.
Tel : (01925) 653944 Fax : (01925) 654861 e-mail : info@binzelabikor.com website : www.binzelabikor.com

IBG
GROUP

Technology for the welder's world.

ABICOR
BINZEL®

Air Cooled

ABIMIG® MIG/MAG Welding Torches

PRO LINE

+ The swan neck can be rotated in **8 positions**.

ABIMIG® 450 TM

Technical Data (EN 60 974-7)

Rating

450 A CO₂
400 A Mixed Gas

Duty Cycle

60%

Wire Size

1.0 - 2.4 mm



High performance, re-inforced plastic handle.



Rotatable swan neck. Easier access for awkward welding positions.



Unique spares. Insulated and threaded gas nozzle - more secure than push-on.

+ Special length manual & automatic torches are available on request.

Manual Torches

Torch

ABIMIG® 450 TM

3 Metre

016.D294RH

4 Metre

016.D295RH

5 Metre

016.D296RH

Technology for the welder's world.



Gas Nozzles

Pack Size = 5

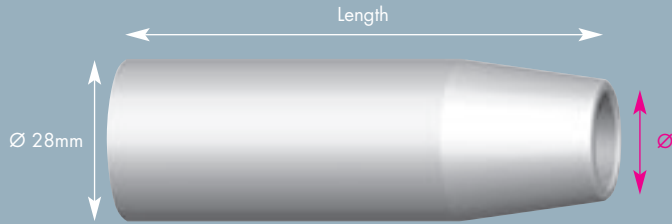

| Ø | Length | Type |
|------|--------|-------------|
| 13mm | 85mm | Conical |
| 16mm | 85mm | Conical |
| 19mm | 85mm | Conical |
| 24mm | 83mm | Cylindrical |

| Part Number |
|-------------|
| 145.D243 |
| 145.D244 |
| 145.D245 |
| 145.D249 |

HD Copper

Gas Nozzles

Pack Size = 5

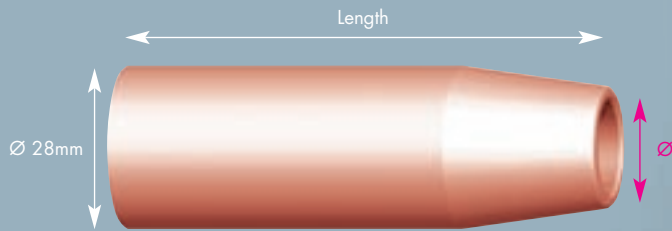

| Ø | Length | Type |
|------|--------|---------|
| 16mm | 85mm | Conical |
| 19mm | 85mm | Conical |

| Part Number |
|-------------|
| 145.D241 |
| 145.D242 |

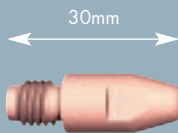

M8 Contact Tips

Pack Size = 50 (ABITIP® plus = 10)

A full range of our M8 contact tips is available.

| Diameter |
|----------|
| Ø 1.0 mm |
| Ø 1.2 mm |
| Ø 1.4 mm |
| Ø 1.6 mm |
| Ø 2.4 mm |

| Standard (E-Cu) |
|-----------------|
| 140.0313 |
| 140.0442 |
| 140.0533 |
| 140.0587 |
| 140.0677 |

| Heavy Duty (CuCrZr) |
|---------------------|
| 140.0316 |
| 140.0445 |
| 140.0536 |
| 140.0590 |
| 140.0679 |

| ABITIP® plus |
|--------------|
| 144.0316 |
| 144.0445 |
| 144.0533 |
| 144.0590 |
| 144.0679 |

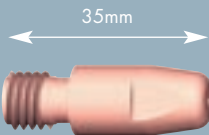

M10 Contact Tips

Pack Size = 50 (ABITIP® = 10)

A full range of our M10 contact tips is available.

| Diameter |
|----------|
| Ø 1.0 mm |
| Ø 1.2 mm |
| Ø 1.4 mm |
| Ø 1.6 mm |
| Ø 2.4 mm |

| Standard (E-Cu) |
|-----------------|
| - |
| - |
| - |
| - |
| - |

| Heavy Duty (CuCrZr) |
|---------------------|
| 140.0348 |
| 140.0481 |
| 140.0547 |
| 140.0616 |
| 140.0698 |

| ABITIP® |
|----------|
| 147.0348 |
| 147.0481 |
| 147.0547 |
| 147.0616 |
| 147.0698 |



Neck Liner

Pack Size = 1

| Wire Size Ø |
|-------------|
| 1.0 - 1.2mm |
| 1.4 - 1.6mm |

| Part No. |
|----------|
| 122.D077 |
| 122.D078 |

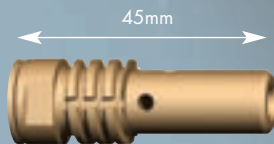

Tip / Nozzle Holder

Pack Size = 10

| |
|-----|
| M8 |
| M10 |

| Part No. |
|----------|
| 016.D155 |
| 016.D156 |



PVC Coated Liners

Protect against gas leakage through liner wall

| Colour | Diameter Ø |
|--------|--------------|
| Orange | 1.0 - 1.2 mm |
| White | 1.4 - 1.6 mm |
| Blue | 2.0 - 2.4 mm |

| 3 Metre |
|----------|
| 124.D039 |
| 124.D044 |
| 124.D049 |

| 4 Metre |
|----------|
| 124.D039 |
| 124.D044 |
| 124.D049 |

| 5 Metre |
|----------|
| 124.D039 |
| 124.D044 |
| 124.D049 |



Swan Neck

| | | ABIMIG® 450 TM |
|-------|----------------|----------------|
| Long | Swan Neck | 016.D147 |
| Short | Swan Neck | 016.D239 |
| 180° | Swan Neck | 016.D255 |
| | Insulator | 016.D154 |
| | Locking Nut | 016.D193 |
| | Neck Interface | 016.D121 |

Handle

| | | ABIMIG® 450 TM |
|--|-----------------|----------------|
| | Complete Handle | 180.D024 |
| | Long Trigger | 185.D065 |
| | Short Trigger | 185.D074 |
| | Trigger Guard | 400.D252 |
| | Cable Support | 400.D205 |
| | Screw | 400.0792 |

Bikox® Power Cable

| | 3 Metre | 4 Metre | 5 Metre |
|-------------|----------|----------|----------|
| Power Cable | 160.D535 | 160.D536 | 160.D537 |

Gun Plug Assembly

| | | ABIMIG® 450 TM |
|--|---------------|----------------|
| | Gun Plug Body | 501.D342 |
| | Liner Nut | 500.0129 |
| | Spring Pins | 501.2378 |
| | Locking Nut | 500.0213 |
| | Black Housing | 501.2454 |
| | Locking Ring | 400.0987 |
| | Cable Support | 400.1010 |

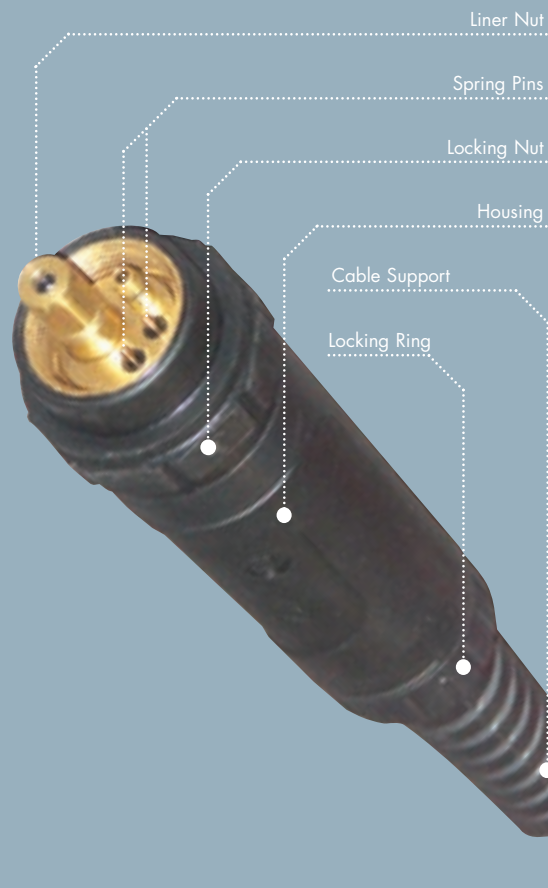

We just want you to be **ABI.**

ABIMIG® TM MIG/MAG Welding Torches High performance, whatever the welding job.

- Air cooled up to 450 A.
- Optimum cooling of the torch – extending torch life.
- BIKOX® R air cooled torches – high flexibility even at low temperatures, extremely UV-resistant, considerably increased temperature stability and tensile strength.
- Time-saving torch change-over due to the ABICOR BINZEL central connector.
- Fast neck change-over reduces down time - extends flexibility.
- Leading quality recognised worldwide.

Introducing the rest of the **ABIMIG® TM** range...

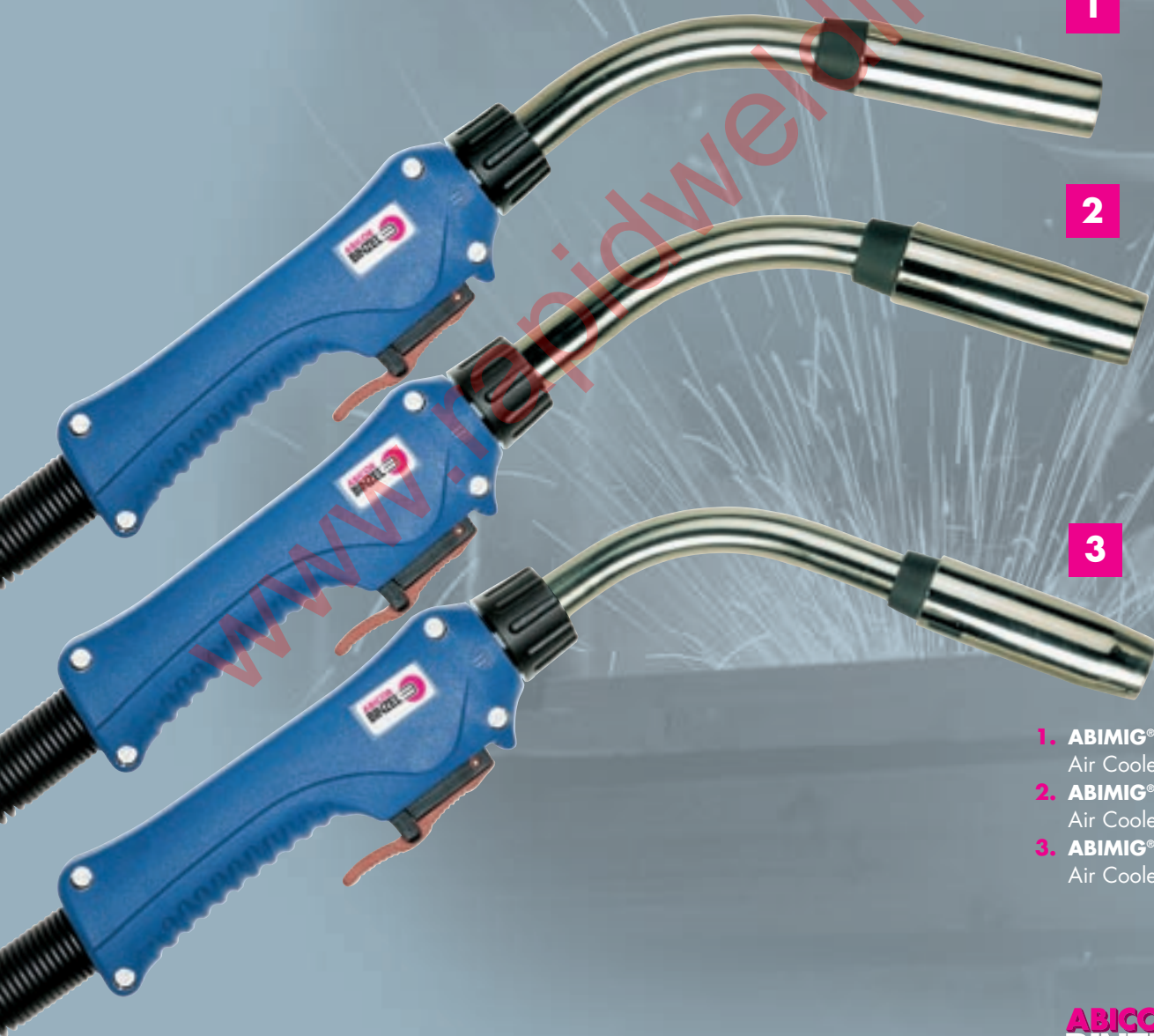

1

2

3

1. **ABIMIG® 250 TM**
Air Cooled
2. **ABIMIG® 350 TM**
Air Cooled
3. **ABIMIG® 400 TM**
Air Cooled

PRO LINE

Alexander Binzel UK Ltd, Binzel House, Mill Lane, Winwick Quay, Warrington, Cheshire. WA2 8UA.
Tel : (01925) 653944 Fax : (01925) 654861 e-mail : info@binzelabikor.com website : www.binzelabikor.com

IBG
GROUP

Technology for the welder's world.

ABICOR
BINZEL®



Liquid Cooled

ABIMIG® MIG/MAG Welding Torches

PROLINE

+ The swan neck can be rotated.

ABIMIG® 240 D WT

Technical Data (EN 60 974-7)

| Rating |
|-----------------------|
| 300 A CO ₂ |
| 270 A Mixed Gas |

| Duty Cycle |
|------------|
| 100% |

| Wire Size |
|--------------|
| 0.8 - 1.2 mm |



High performance, re-inforced plastic handle.



Rotatable swan neck. Easier access for awkward welding positions.



Same consumables as industry standard MB range.

+ Special length manual torches are available on request.

Manual Torches

Torch
ABIMIG® 240 D WT

| 3 Metre |
|----------|
| 023.D015 |

| 4 Metre |
|----------|
| 023.D016 |

| 5 Metre |
|----------|
| 023.D017 |

Technology for the welder's world.



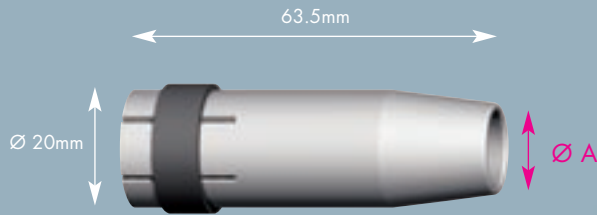

| Ø A | Type | Part Number |
|----------|--------------------|-------------|
| Ø 17mm | Cylindrical | 145.0047 |
| Ø 12.5mm | Conical | 145.0080 |
| Ø 10mm | Tapered | 145.0128 |

Gas Nozzles

Pack Size = 10

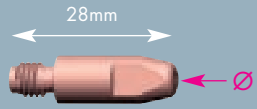

M6 Contact Tips

Pack Size = 50 (ABITIP® plus = 10)

+ A full range of our M6 contact tips is available.

| Diameter | Standard (E-Cu) | Heavy Duty (CuCrZr) | Aluminium | ABITIP® plus |
|----------|-----------------|---------------------|-----------|--------------|
| Ø 0.8 mm | 140.0051 | 140.0054 | 141.0001 | 144.0054 |
| Ø 1.0 mm | 140.0242 | 140.0245 | 141.0006 | 144.0245 |
| Ø 1.2 mm | 140.0379 | 140.0382 | 141.0010 | 144.0382 |

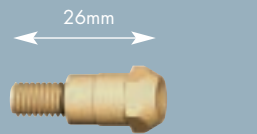

Std Tip Adaptor

Pack Size = 10

| M6 | Std |
|----|----------|
| | 142.0003 |

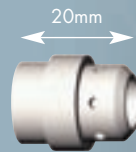

Gas Diffusor

Pack Size = 10

| Standard | Part Number |
|----------|-------------|
| | 012.0183 |



Neck Liner

| Wire Size Ø | Part Number |
|-------------|-------------|
| 0.8 - 1.2mm | 123.D097 |



Brass Neck Liner

For Aluminium wire.

| Wire Size Ø | Part Number |
|-------------|-------------|
| 0.8 - 1.0mm | 120.D145 |
| 1.2 - 1.4mm | 120.D146 |



Steel Liners

Uncoated liner carry gas separate from the wire/liner

| Colour | Diameter Ø | 3 Metre | 4 Metre | 5 Metre | 50 Metre Coil |
|--------|--------------|----------|----------|----------|---------------|
| Grey | 0.6 - 0.8 mm | 122.0005 | 122.0007 | 122.0009 | 120.0009 |
| White | 1.0 - 1.2 mm | 122.0031 | 122.0036 | 122.0039 | 120.0026 |



PTFE Liners

To be used for Aluminium welding

| Colour | Diameter Ø | 3 Metre | 4 Metre | 5 Metre | 50 Metre Coil |
|--------|--------------|----------|----------|----------|---------------|
| Blue | 0.6 - 0.8 mm | 126.0005 | 126.0008 | 126.0011 | 125.0004 |
| Red | 1.0 - 1.2 mm | 126.0021 | 126.0026 | 126.0028 | 125.0006 |

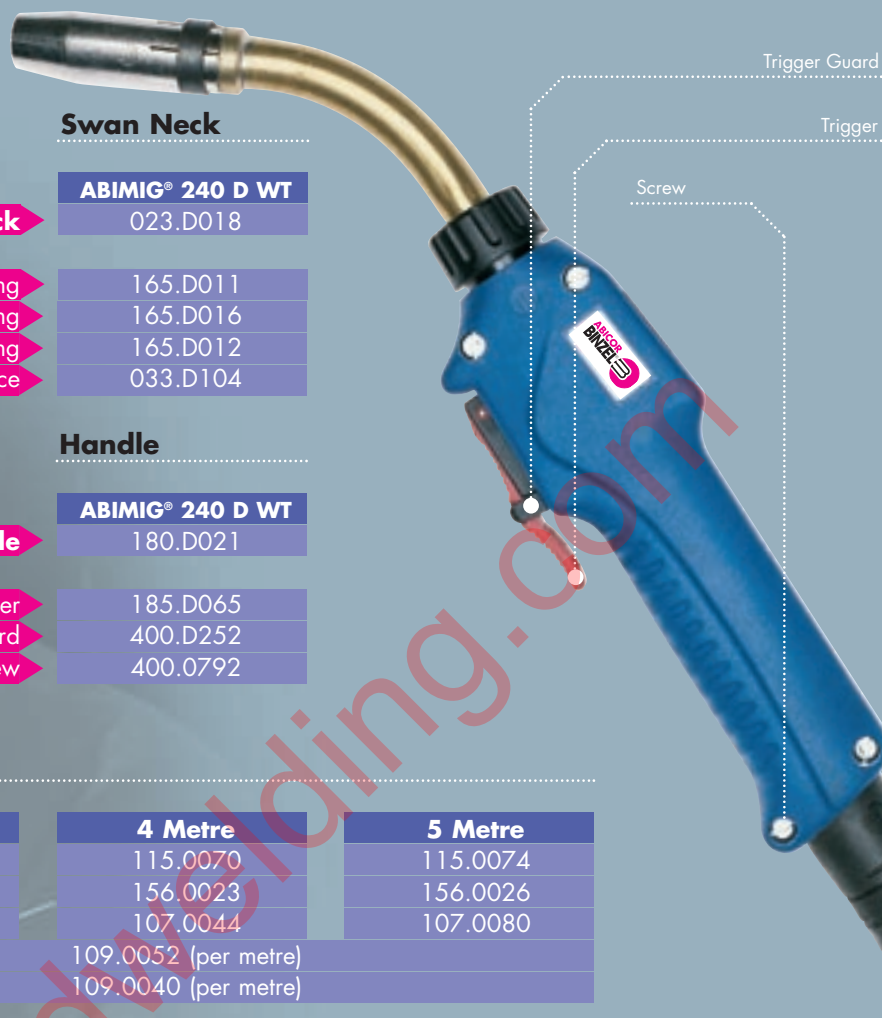

Swan Neck

| | | ABIMIG® 240 D WT |
|--------|----------------|------------------|
| 50° | Swan Neck | 023.D018 |
| Small | Neck O-Ring | 165.D011 |
| Medium | Neck O-Ring | 165.D016 |
| Large | Neck O-Ring | 165.D012 |
| | Neck Interface | 033.D104 |

Handle

| | | ABIMIG® 240 D WT |
|--|-----------------|------------------|
| | Complete Handle | 180.D021 |
| | Trigger | 185.D065 |
| | Trigger Guard | 400.D252 |
| | Screw | 400.0792 |

Cable Assembly

| | 3 Metre | 4 Metre | 5 Metre |
|--------------|----------------------|----------|----------|
| Power Cable | 115.0065 | 115.0070 | 115.0074 |
| Wire Conduit | 156.0019 | 156.0023 | 156.0026 |
| Outer Cover | 107.0079 | 107.0044 | 107.0080 |
| Water Hose | 109.0052 (per metre) | | |
| Gas Hose | 109.0040 (per metre) | | |

+ A full range of our **Hose Clamps & Quick connectors** is available.

Water & Gas Hose Parts

| | Water Hose | Gas Hose |
|-----------------|------------|----------|
| Hose Clamp | 173.0001 | 171.0002 |
| Quick Connector | 501.0114 | - |
| Fastening Cap | 501.2423 | - |
| Fastening Cap | 501.2424 | - |
| Hose Marker | 501.2166 | - |
| Hose Marker | 501.2167 | - |

Gun Plug Assembly

| | | ABIMIG® 240 D WT |
|--|----------------|------------------|
| | Gun Plug Body | 501.0015 |
| | Liner Nut | 501.0082 |
| | Spring Pins | 501.2378 |
| | Locking Nut | 500.0213 |
| | Black Housing | 500.0342 |
| | Spring Support | 500.0233 |



We just want you to be **ABI.**

ABIMIG® WT MIG/MAG Welding Torches High performance, whatever the welding job.

- Liquid cooled up to 500 A.
- Optimum cooling of the torch – extending torch life.
- Time-saving torch change-over due to the ABICOR BINZEL central connector.
- Fast neck change-over reduces down time - extends flexibility.
- Leading quality recognised worldwide.

Introducing the rest of the **ABIMIG® WT** Liquid Cooled range...

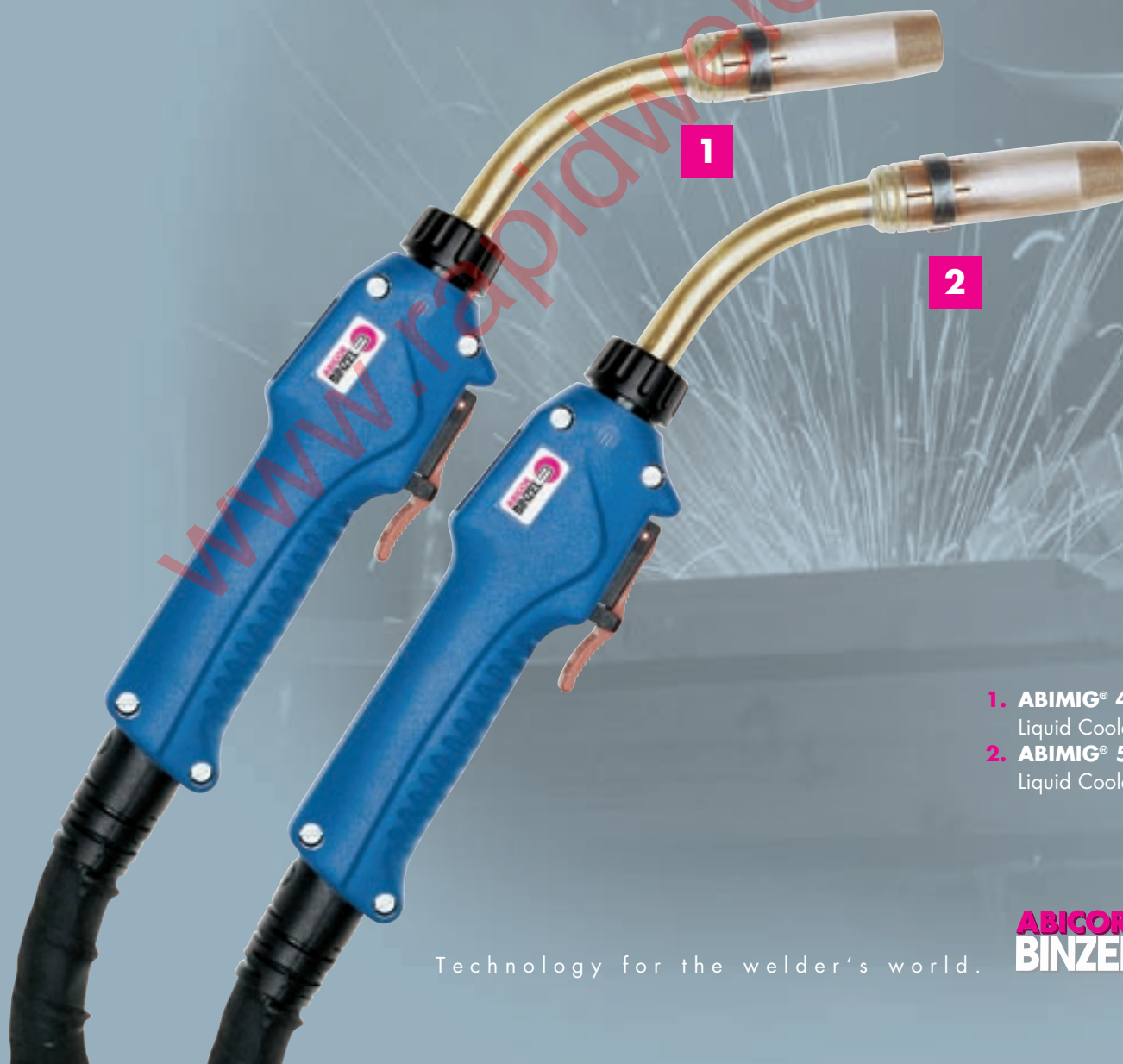

1. **ABIMIG® 401 D WT**
Liquid Cooled
2. **ABIMIG® 501 D WT**
Liquid Cooled

Technology for the welder's world.



PROLINE

Alexander Binzel UK Ltd, Binzel House, Mill Lane, Winwick Quay, Warrington, Cheshire, WA2 8UA.
Tel : (01925) 653944 Fax : (01925) 654861 e-mail : info@binzelabikor.com website : www.binzelabikor.com

IBG
GROUP

Liquid Cooled

ABIMIG® MIG/MAG Welding Torches

PROLINE

+ The swan neck can be rotated.

ABIMIG® 401 D WT

Technical Data (EN 60 974-7)

| Rating |
|-----------------------|
| 400 A CO ² |
| 350 A Mixed Gas |

| Duty Cycle |
|------------|
| 100% |

| Wire Size |
|--------------|
| 0.8 - 1.2 mm |

ABIMIG® 501 D WT

Technical Data (EN 60 974-7)

| Rating |
|-----------------------|
| 500 A CO ² |
| 450 A Mixed Gas |

| Duty Cycle |
|------------|
| 100% |

| Wire Size |
|--------------|
| 0.8 - 1.6 mm |

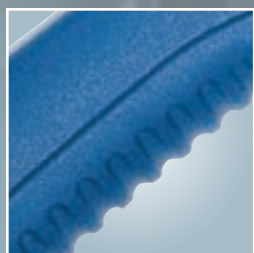

High performance, re-inforced plastic handle.



Rotatable swan neck. Easier access for awkward welding positions.



Same consumables as industry standard MB range.

+ **Special length** manual torches are available on request.

Manual Torches

| Torch |
|-------------------------|
| ABIMIG® 401 D WT |
| ABIMIG® 501 D WT |

| 3 Metre |
|----------|
| 033.D065 |
| 034.D030 |

| 4 Metre |
|----------|
| 033.D066 |
| 034.D031 |

| 5 Metre |
|----------|
| 033.D067 |
| 034.D032 |

Technology for the welder's world.



Gas Nozzles

Pack Size = 10

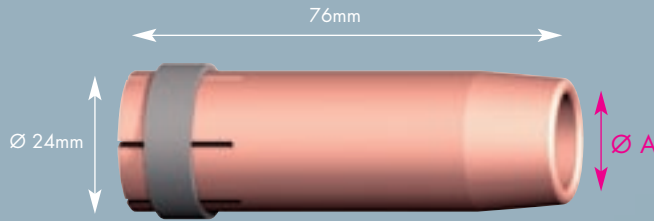

| Ø A | Type | Part Number |
|--------|--------------------|-------------|
| Ø 20mm | Cylindrical | 145.0051 |
| Ø 16mm | Conical | 145.0085 |
| Ø 14mm | Tapered | 145.0132 |

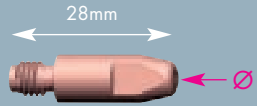

M6 Contact Tips

Pack Size = 50 (ABITIP® plus = 10)

+ A full range of our M6 contact tips is available.

| Diameter | Standard (E-Cu) | Heavy Duty (CuCrZr) | Aluminium | ABITIP® plus |
|----------|-----------------|---------------------|-----------|--------------|
| Ø 0.8 mm | 140.0051 | 140.0054 | 141.0001 | 144.0054 |
| Ø 1.0 mm | 140.0242 | 140.0245 | 141.0006 | 144.0245 |
| Ø 1.2 mm | 140.0379 | 140.0382 | 141.0010 | 144.0382 |
| Ø 1.4 mm | 140.0533 | 140.0536 | 141.0055 | 144.0536 |
| Ø 1.6 mm | 140.0587 | 140.0590 | 141.0022 | 144.0590 |

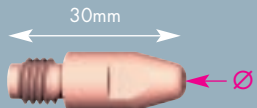

M8 Contact Tips

Pack Size = 50 (ABITIP® plus = 10)

+ A full range of our M8 contact tips is available.

| Diameter | Standard (E-Cu) | Heavy Duty (CuCrZr) | Aluminium | ABITIP® plus |
|----------|-----------------|---------------------|-----------|--------------|
| Ø 0.8 mm | 140.0114 | 140.0117 | 141.0003 | 144.0117 |
| Ø 1.0 mm | 140.0313 | 140.0316 | 141.0008 | 144.0316 |
| Ø 1.2 mm | 140.0442 | 140.0445 | 141.0015 | 144.0445 |
| Ø 1.4 mm | 140.0516 | 140.0519 | 141.0019 | 144.0519 |
| Ø 1.6 mm | 140.0555 | 140.0558 | 141.0020 | 144.0558 |

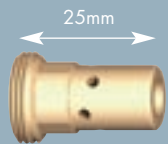

Std Tip Adaptor

Pack Size = 10

| | Std |
|-----------|----------|
| M6 | 142.0008 |
| M8 | 142.0022 |

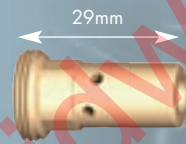

Long Tip Adaptor

Pack Size = 10

| Length | Long |
|--------|----------|
| 29mm | 142.0013 |
| 31mm | 142.0027 |

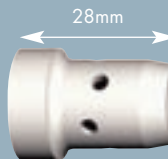

Gas Diffusor

Pack Size = 10

| | Part Number |
|-------------------------|-------------|
| Standard Ceramic | 030.0145 |
| | 030.0190 |

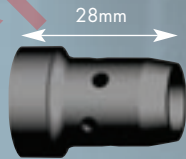

HD Gas Diffusor

Pack Size = 10

| | Part Number |
|-------------------|-------------|
| Heavy Duty | 030.0037 |



Neck Liner

| Wire Size Ø | Standard |
|-------------|----------|
| 1.0 - 1.2mm | 123.D097 |
| 1.4 - 1.6mm | 123.D098 |



Brass Neck Liner

For Aluminium wire.

| Wire Size Ø | Part Number |
|-------------|-------------|
| 0.8 - 1.0mm | 120.D145 |
| 1.2 - 1.4mm | 120.D146 |



Steel Liners

Uncoated liner carry gas separate from the wire/liner

| Colour | Diameter Ø | 3 Metre | 4 Metre | 5 Metre | 50 Metre Coil |
|--------|--------------|----------|----------|----------|---------------|
| Grey | 0.6 - 0.8 mm | 122.0005 | 122.0007 | 122.0009 | 120.0009 |
| Grey | 1.0 - 1.2 mm | 122.0031 | 122.0036 | 122.0039 | 120.0026 |
| Grey | 1.4 - 1.6 mm | 122.0056 | 122.0060 | 122.0063 | - |



PTFE Liners

To be used for Aluminium welding

| Colour | Diameter Ø | 3 Metre | 4 Metre | 5 Metre | 50 Metre Coil |
|--------|--------------|----------|----------|----------|---------------|
| Blue | 0.6 - 0.8 mm | 126.0005 | 126.0008 | 126.0011 | 125.0004 |
| Red | 1.0 - 1.2 mm | 126.0021 | 126.0026 | 126.0028 | 125.0006 |
| Yellow | 1.4 - 1.6 mm | 126.0039 | 126.0042 | 126.0045 | 125.0017 |

Swan Neck

| | | ABIMIG® 401 D WT | ABIMIG® 501 D WT |
|--------|------------------|------------------|------------------|
| Long | Swan Neck | 033.D052 | 034.D033 |
| Short | Swan Neck | 033.D068 | - |
| Small | Neck O-Ring | 165.D011 | 165.D011 |
| Medium | Neck O-Ring | 165.D016 | 165.D016 |
| Large | Neck O-Ring | 165.D012 | 165.D012 |
| | Insulator | 030.0019 | 030.0019 |
| | Neck Interface | 033.D058 | 033.D058 |

Handle

| | | ABIMIG® 401 D WT | ABIMIG® 501 D WT |
|--|------------------------|------------------|------------------|
| | Complete Handle | 180.D021 | 180.D021 |
| | Trigger | 185.D065 | 180.D065 |
| | Trigger Guard | 400.D252 | 400.D252 |
| | Screw | 400.0792 | 400.0792 |

Cable Assembly

| | 3 Metre | 4 Metre | 5 Metre |
|---------------------|----------|----------------------|----------|
| Power Cable | 115.0065 | 115.0070 | 115.0074 |
| Wire Conduit | 156.0019 | 156.0023 | 156.0026 |
| Outer Cover | 107.0079 | 107.0044 | 107.0080 |
| Water Hose | | 109.0052 (per metre) | |
| Gas Hose | | 109.0040 (per metre) | |

+ A full range of our **Hose Clamps & Quick connectors** is available.

Water & Gas Hose Parts

| | Water Hose | Gas Hose |
|------------------------|------------|----------|
| Hose Clamp | 173.0001 | 171.0002 |
| Quick Connector | 501.0114 | - |
| Fastening Cap | 501.2423 | - |
| Fastening Cap | 501.2424 | - |
| Hose Marker | 501.2166 | - |
| Hose Marker | 501.2167 | - |

Gun Plug Assembly

| | ABIMIG® 401 D WT | ABIMIG® 501 D WT |
|----------------------|------------------|------------------|
| Gun Plug Body | 501.0015 | 501.0015 |
| Liner Nut | 501.0082 | 501.0082 |
| Spring Pins | 501.2378 | 501.2378 |
| Locking Nut | 500.0213 | 500.0213 |
| Black Housing | 500.0342 | 500.0342 |
| Spring Support | 500.0233 | 500.0233 |

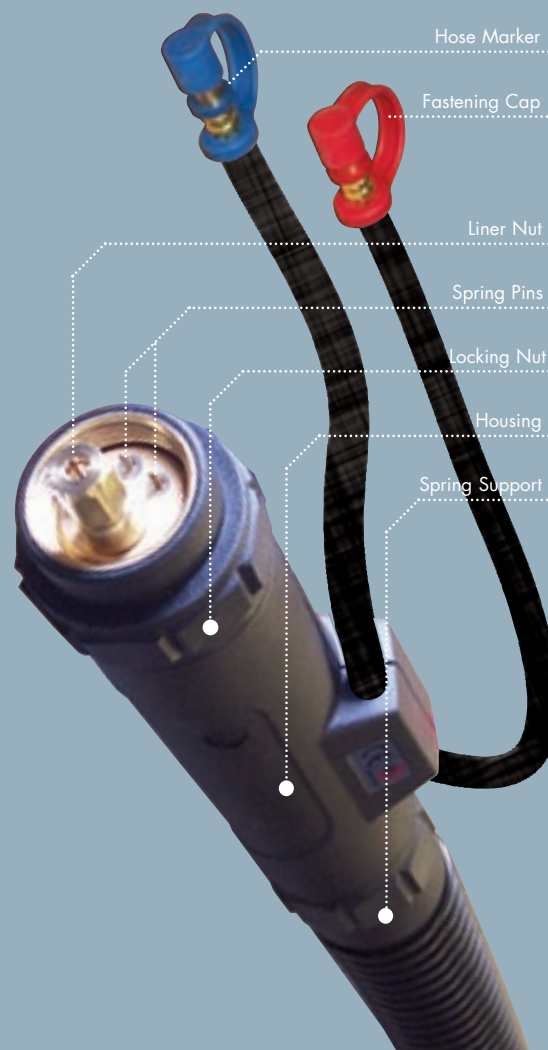
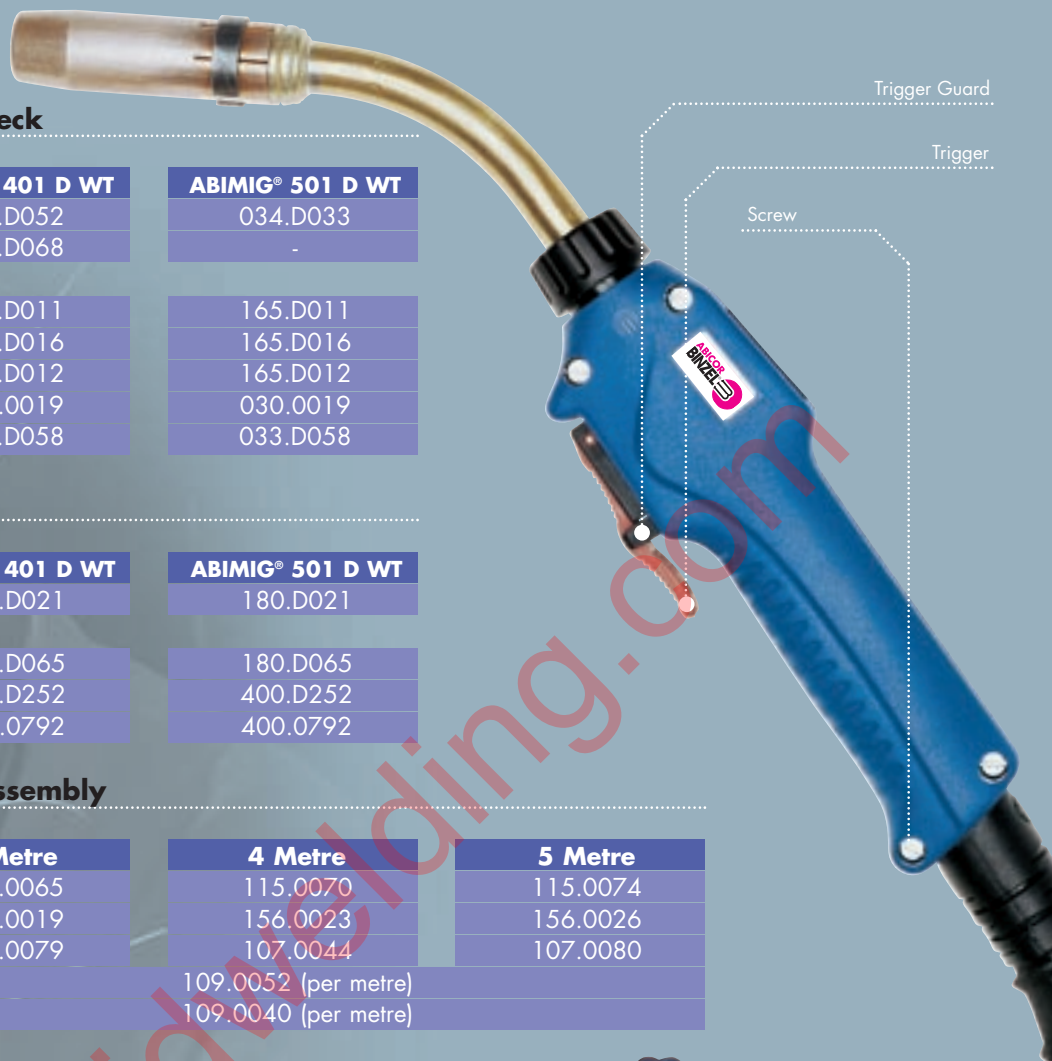

We just want you to be **ABI**.

ABIMIG® WT MIG/MAG Welding Torches High performance, whatever the welding job.

- Liquid cooled up to 500 A.
- Optimum cooling of the torch – extending torch life.
- Time-saving torch change-over due to the ABICOR BINZEL central connector.
- Fast neck change-over reduces down time - extends flexibility.
- Leading quality recognised worldwide.

Introducing the rest of the **ABIMIG® WT** Liquid Cooled range...



1. ABIMIG® 240 D WT
Liquid Cooled

Technology for the welder's world.



PROLINE

Alexander Binzel UK Ltd, Binzel House, Mill Lane, Winwick Quay, Warrington, Cheshire. WA2 8UA.
Tel : (01925) 653944 Fax : (01925) 654861 e-mail : info@binzelabikor.com website : www.binzelabikor.com

IBG
GROUP

Liquid Cooled

ABIMIG® MIG/MAG Welding Torches

PRO LINE



The **double cooling circuit** plus the large areas for current & heat transfer, prevents overheating of the torch & reduces spatter adhesion.

Outer Cooling Circuit

Inner Cooling Circuit

ABIMIG® 452 D W

Technical Data (EN 60 974-7)

Rating

450 A DC
300 A Pulse
Mixed Gas

Duty Cycle

100%

Wire Size

0.8 - 1.6 mm



Ball jointed cable assembly, wide excursion range.

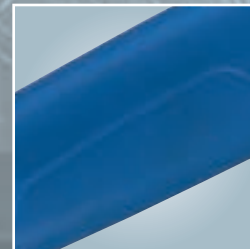

Ergonomically designed handle for maximum operator comfort.



Same consumables as industry standard MB range.



Special length manual torches are available on request.

Manual Torches

Torch

ABIMIG® 452 D W

3 Metre

766.0400

4 Metre

766.0401

5 Metre

766.0402

Technology for the welder's world.



Gas Nozzles

Pack Size = 10

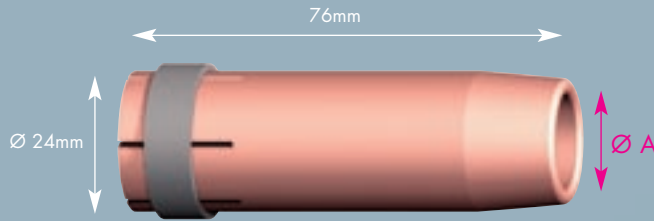

| Ø A | Type |
|--------|--------------------|
| Ø 20mm | Cylindrical |
| Ø 16mm | Conical |
| Ø 14mm | Tapered |

| Part Number |
|-------------|
| 145.0051 |
| 145.0085 |
| 145.0132 |

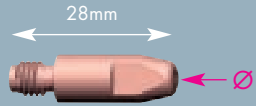

M6 Contact Tips

Pack Size = 50 (ABITIP® plus = 10)



A full range of our **M6** contact tips is available.

| Diameter |
|----------|
| Ø 0.8 mm |
| Ø 1.0 mm |
| Ø 1.2 mm |
| Ø 1.4 mm |
| Ø 1.6 mm |

| Standard (E-Cu) |
|-----------------|
| 140.0051 |
| 140.0242 |
| 140.0379 |
| 140.0533 |
| 140.0587 |

| Heavy Duty (CuCrZr) |
|---------------------|
| 140.0054 |
| 140.0245 |
| 140.0382 |
| 140.0536 |
| 140.0590 |

| Aluminium |
|-----------|
| 141.0001 |
| 141.0006 |
| 141.0010 |
| 141.0055 |
| 141.0022 |

| ABITIP® plus |
|--------------|
| 144.0054 |
| 144.0245 |
| 144.0382 |
| 144.0536 |
| 144.0590 |

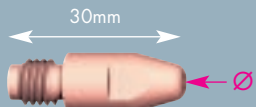

M8 Contact Tips

Pack Size = 50 (ABITIP® plus = 10)



A full range of our **M8** contact tips is available.

| Diameter |
|----------|
| Ø 0.8 mm |
| Ø 1.0 mm |
| Ø 1.2 mm |
| Ø 1.4 mm |
| Ø 1.6 mm |

| Standard (E-Cu) |
|-----------------|
| 140.0114 |
| 140.0313 |
| 140.0442 |
| 140.0516 |
| 140.0555 |

| Heavy Duty (CuCrZr) |
|---------------------|
| 140.0117 |
| 140.0316 |
| 140.0445 |
| 140.0519 |
| 140.0558 |

| Aluminium |
|-----------|
| 141.0003 |
| 141.0008 |
| 141.0015 |
| 141.0019 |
| 141.0020 |

| ABITIP® plus |
|--------------|
| 144.0117 |
| 144.0316 |
| 144.0445 |
| 144.0519 |
| 144.0558 |

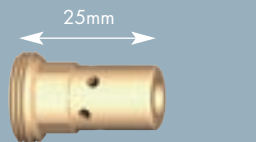

Std Tip Adaptor

Pack Size = 10

| |
|-----------|
| M6 |
| M8 |

| Std |
|----------|
| 142.0008 |
| 142.0022 |



Long Tip Adaptor

Pack Size = 10

| Length | M6 | M8 |
|--------|----|----|
| 29mm | | |
| 31mm | | |

| Long |
|----------|
| 142.0013 |
| 142.0027 |

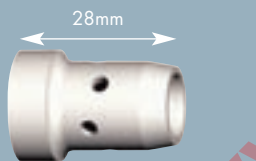

Gas Diffusor

Pack Size = 10

| Part Number |
|-------------|
| 030.0145 |
| 030.0190 |

| |
|-----------------|
| Standard |
| Ceramic |

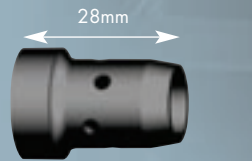

HD Gas Diffusor

Pack Size = 10

| Part Number |
|-------------|
| 030.0037 |

| |
|-------------------|
| Heavy Duty |
|-------------------|

Steel Liners

Uncoated liner carry gas separate from the wire/liner

| Colour | Diameter Ø |
|--------|--------------|
| Grey | 0.6 - 0.8 mm |
| White | 1.0 - 1.2 mm |
| Black | 1.4 - 1.6 mm |

| 3 Metre |
|----------|
| 122.0005 |
| 122.0031 |
| 122.0056 |

| 4 Metre |
|----------|
| 122.0007 |
| 122.0036 |
| 122.0060 |

| 5 Metre |
|----------|
| 122.0009 |
| 122.0039 |
| 122.0063 |

| 50 Metre Coil |
|---------------|
| 120.0009 |
| 120.0026 |
| - |

PTFE Liners

To be used for Aluminium welding

| Colour | Diameter Ø |
|--------|--------------|
| Blue | 0.6 - 0.8 mm |
| Red | 1.0 - 1.2 mm |
| Yellow | 1.4 - 1.6 mm |

| 3 Metre |
|----------|
| 126.0005 |
| 126.0021 |
| 126.0039 |

| 4 Metre |
|----------|
| 126.0008 |
| 126.0026 |
| 126.0042 |

| 5 Metre |
|----------|
| 126.0011 |
| 126.0028 |
| 126.0045 |

| 50 Metre Coil |
|---------------|
| 125.0004 |
| 125.0006 |
| 125.0017 |

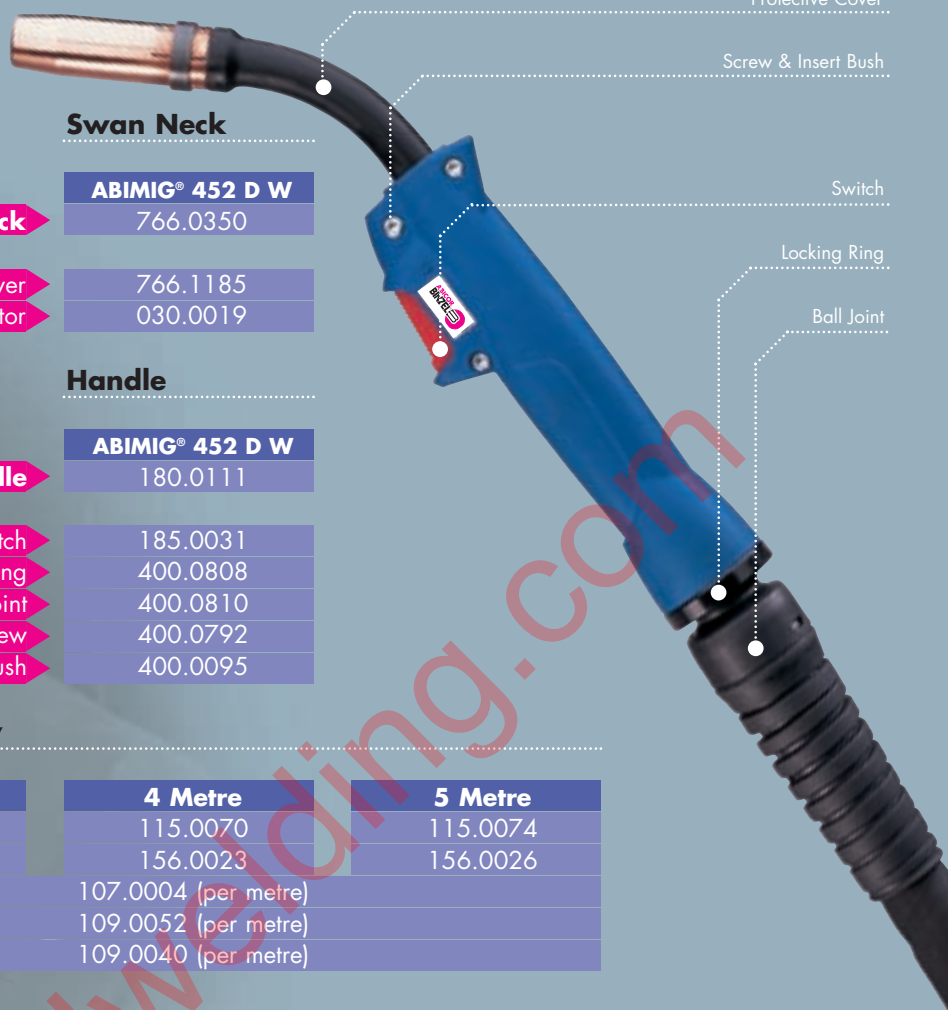

Swan Neck

| | |
|------------------|------------------------|
| | ABIMIG® 452 D W |
| 50° Swan Neck | 766.0350 |
| Protective Cover | 766.1185 |
| Insulator | 030.0019 |

Handle

| | |
|-----------------|------------------------|
| | ABIMIG® 452 D W |
| Complete Handle | 180.0111 |
| Switch | 185.0031 |
| Locking Ring | 400.0808 |
| Ball Joint | 400.0810 |
| Screw | 400.0792 |
| Insert Bush | 400.0095 |

Cable Assembly

| | 3 Metre | 4 Metre | 5 Metre |
|--------------|----------|----------------------|----------|
| Power Cable | 115.0065 | 115.0070 | 115.0074 |
| Wire Conduit | 156.0019 | 156.0023 | 156.0026 |
| Outer Cover | | 107.0004 (per metre) | |
| Water Hose | | 109.0052 (per metre) | |
| Gas Hose | | 109.0040 (per metre) | |

+ A full range of our **Hose Clamps & Quick connectors** is available.

Water & Gas Hose Parts

| | Water Hose | Gas Hose |
|-----------------|------------|----------|
| Hose Clamp | 173.0001 | 171.0002 |
| Quick Connector | 501.0114 | - |
| Fastening Cap | 501.2423 | - |
| Fastening Cap | 501.2424 | - |
| Hose Marker | 501.2166 | - |
| Hose Marker | 501.2167 | - |

Gun Plug Assembly

| | |
|----------------|------------------------|
| | ABIMIG® 452 D W |
| Gun Plug Body | 501.0015 |
| Liner Nut | 501.0082 |
| Spring Pins | 501.2378 |
| Locking Nut | 500.0213 |
| Black Housing | 500.0342 |
| Spring Support | 500.0233 |

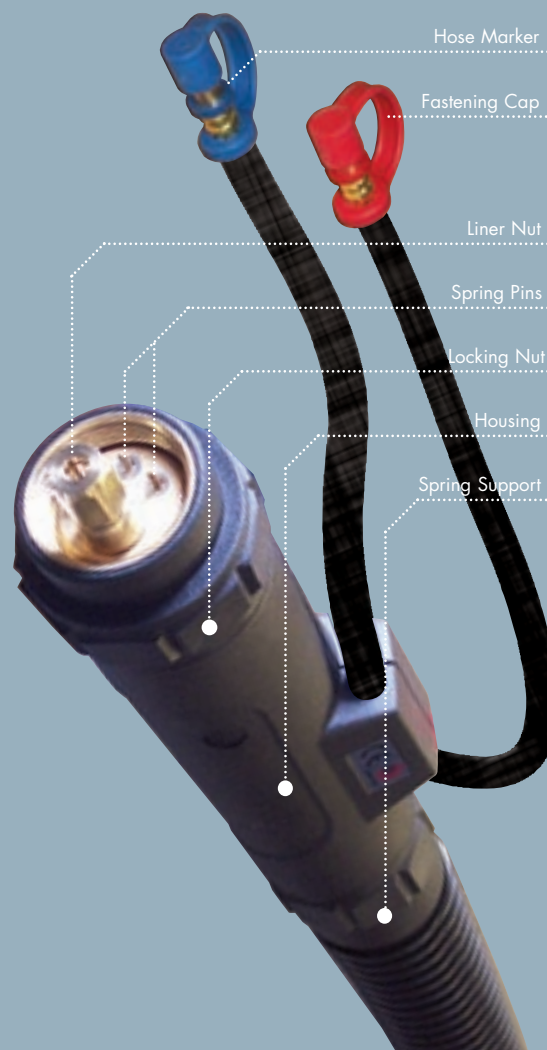

We just want you to be **ABI.**

ABIMIG® MIG/MAG Welding Torches High performance, whatever the welding job.

- Liquid cooled up to 500 A.
- Optimum cooling of the torch – extending torch life.
- Time-saving torch change-over due to the ABICOR BINZEL central connector.
- Fast neck change-over reduces down time - extends flexibility.
- Leading quality recognised worldwide.

Introducing the rest of the **ABIMIG®** Liquid Cooled range...



- 1. ABIMIG® 240 D WT**
Liquid Cooled
- 2. ABIMIG® 401 D WT**
Liquid Cooled
- 3. ABIMIG® 501 D WT**
Liquid Cooled

Technology for the welder's world.

**ABICOR
BINZEL®**

PROLINE

Alexander Binzel UK Ltd, Binzel House, Mill Lane, Winwick Quay, Warrington, Cheshire, WA2 8UA.
Tel : (01925) 653944 Fax : (01925) 654861 e-mail : info@binzelabikor.com website : www.binzelabikor.com

**IBG
GROUP**

Air Cooled

RAB *plus* MIG/MAG Welding Torches

FUMELINE



RAB *plus* 15 AK

Technical Data (EN 60 974-7)

| Rating | Duty Cycle | Wire Size |
|-----------------------|------------|--------------|
| 180 A CO ² | 60% | 0.6 - 1.2 mm |
| 150 A Mixed Gas | | |



Direct extraction at the arc guarantees welders protection against harmful fumes.



Handle complete with extraction control and swivel joint for optimized handling.

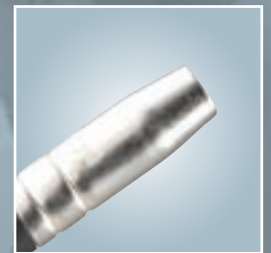

Same consumables as industry standard MB range.



WITHOUT FUME EXTRACTION



WITH FUME EXTRACTION

+ Special length manual torches are available on request.

Manual Torches

| Torch | 3 Metre | 4 Metre | 5 Metre |
|------------------------------|----------|----------|----------|
| RAB <i>plus</i> 15 AK | 602.2004 | 602.2005 | 602.2006 |

Technology for the welder's world.



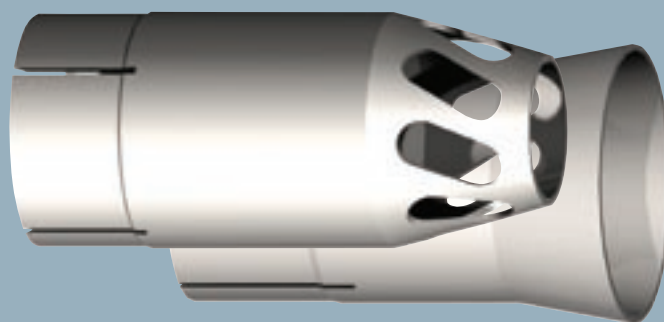
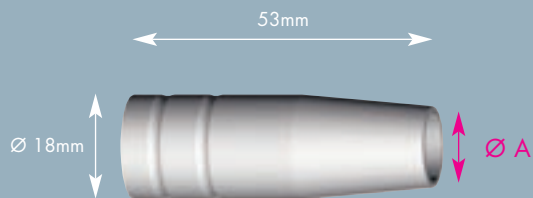

Gas Nozzles

Pack Size = 10

| Ø A | Type | Part Number |
|---------|--------------------|-------------|
| Ø 16mm | Cylindrical | 145.0041 |
| Ø 12mm | Conical | 145.0075 |
| Ø 9.5mm | Tapered | 145.0123 |

Fume Nozzles

Pack Size = 1

| Part Number | Standard | Funnel |
|-------------|----------|----------|
| | 600.2003 | 602.0040 |

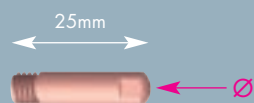

M6 Contact Tips

Pack Size = 50

| Diameter | Standard (E-Cu) |
|----------|-----------------|
| Ø 0.6 mm | 140.0008 |
| Ø 0.8 mm | 140.0059 |
| Ø 1.0 mm | 140.0253 |
| Ø 1.2 mm | 140.0387 |

| Heavy Duty (CuCrZr) | Aluminium |
|---------------------|-----------|
| - | - |
| 140.0062 | 141.0002 |
| 140.0256 | 141.0007 |
| 140.0390 | 141.0011 |

+ A full range of our M6 contact tips is available.

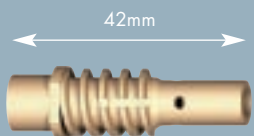

Nozzle Holder

Pack Size = 2

| M6 | Std |
|----|----------|
| | 002.0078 |



Nozzle Spring

Pack Size = 10

| Std |
|----------|
| 002.0058 |



PVC Coated Liners

Protects against gas leakage through liner wall

| Colour | Diameter Ø | 3 Metre | 4 Metre | 5 Metre | 50 Metre Coil |
|--------|--------------|----------|----------|----------|---------------|
| Blue | 0.6 - 0.8 mm | 124.0011 | 124.0012 | 124.0015 | 123.0004 |
| Red | 1.0 - 1.2 mm | 124.0026 | 124.0031 | 124.0035 | 123.0010 |



PTFE Liners

To be used for Aluminium welding

| Colour | Diameter Ø | 3 Metre | 4 Metre | 5 Metre | 50 Metre Coil |
|--------|--------------|----------|----------|----------|---------------|
| Blue | 0.6 - 0.8 mm | 126.0005 | 126.0008 | 126.0011 | 125.0004 |
| Red | 1.0 - 1.2 mm | 126.0021 | 126.0026 | 126.0028 | 125.0006 |

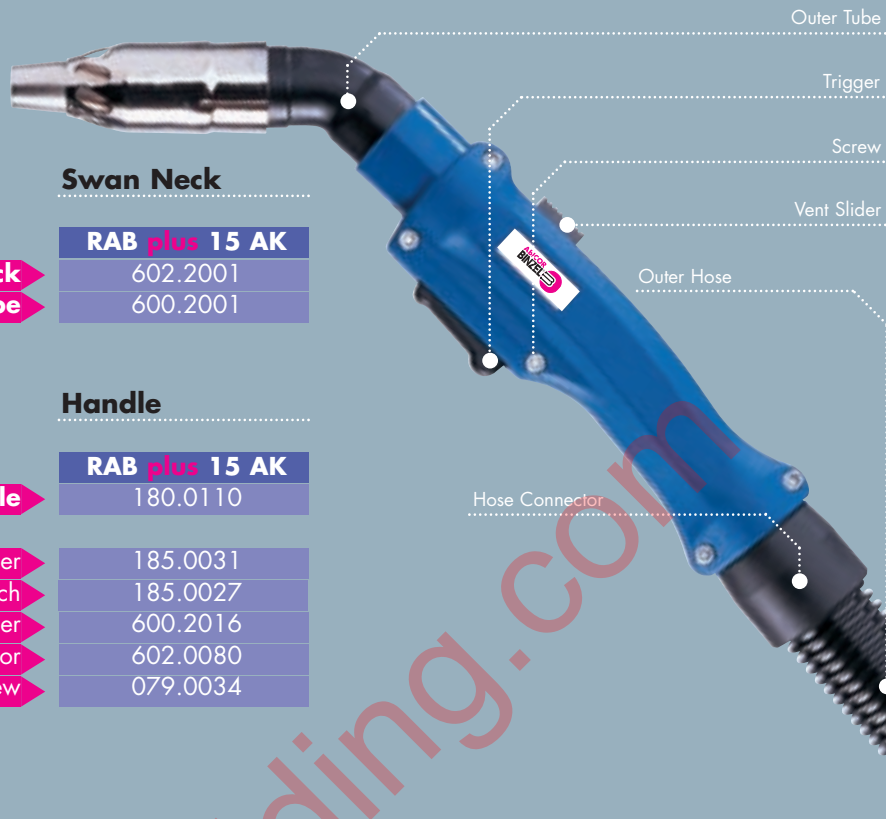

Swan Neck

| | RAB plus 15 AK |
|-------------------|-----------------------|
| Inner Neck | 602.2001 |
| Outer Tube | 600.2001 |

Handle

| | RAB plus 15 AK |
|------------------------|-----------------------|
| Complete Handle | 180.0110 |
| Trigger | 185.0031 |
| Microswitch | 185.0027 |
| Vent Slider | 600.2016 |
| Hose Connector | 602.0080 |
| Screw | 079.0034 |

Cable Assembly

| | 3 Metre | 4 Metre | 5 Metre |
|---------------------|----------------------|----------|----------|
| Bikox® Cable | 160.0065 | 160.0078 | 160.0091 |
| Outer Hose | 109.0042 (per metre) | | |

Gun Plug Assembly

| | RAB plus 15 AK |
|------------------------|-----------------------|
| Gun Plug Body | 501.0003 |
| Liner Nut | 501.0082 |
| Spring Pins | 501.2378 |
| Locking Nut | 500.0213 |
| Black Housing | 501.2278 |
| T-piece Hose Connector | 602.0082 |

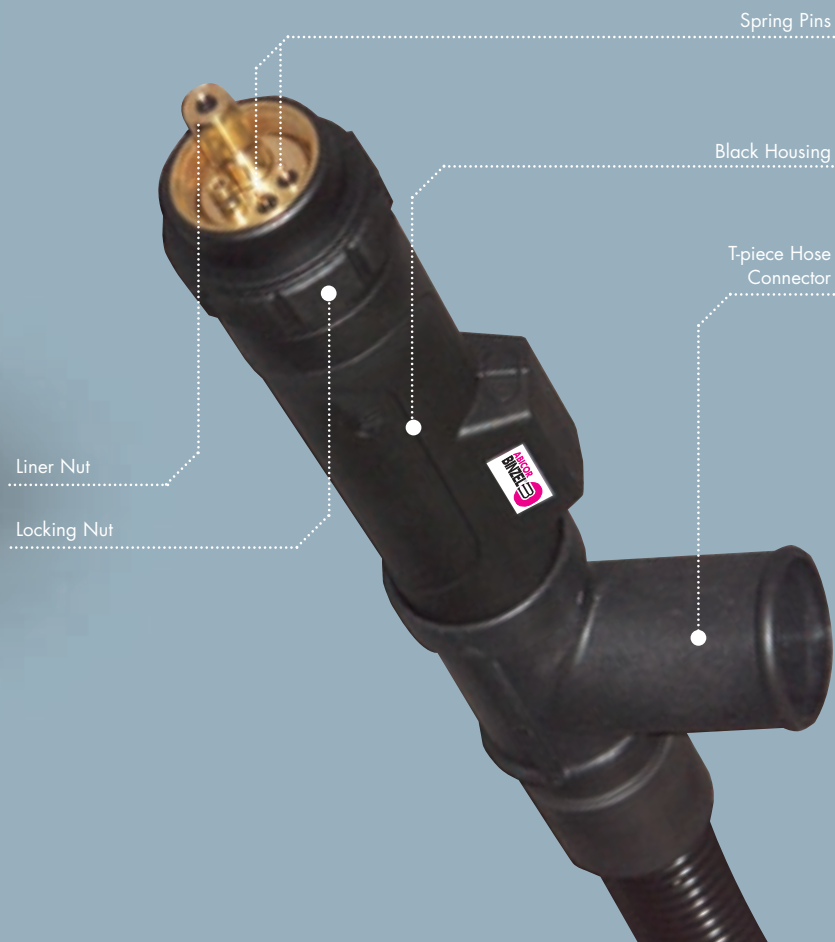

Fume Extraction at the Source.

RAB *plus* MIG/MAG Welding Torches Worldwide recognised.

- Air cooled up to 300 A.
- Liquid cooled up to 500 A.
- Direct extraction at the arc guarantees welders protection against harmful fumes.
- Small extraction tube diameter - better accessibility.
- Aluminium outer tube - considerable weight saving.
- Handle with extraction control and swivel joint - optimized handling.

Introducing the rest of the RAB *plus* range...

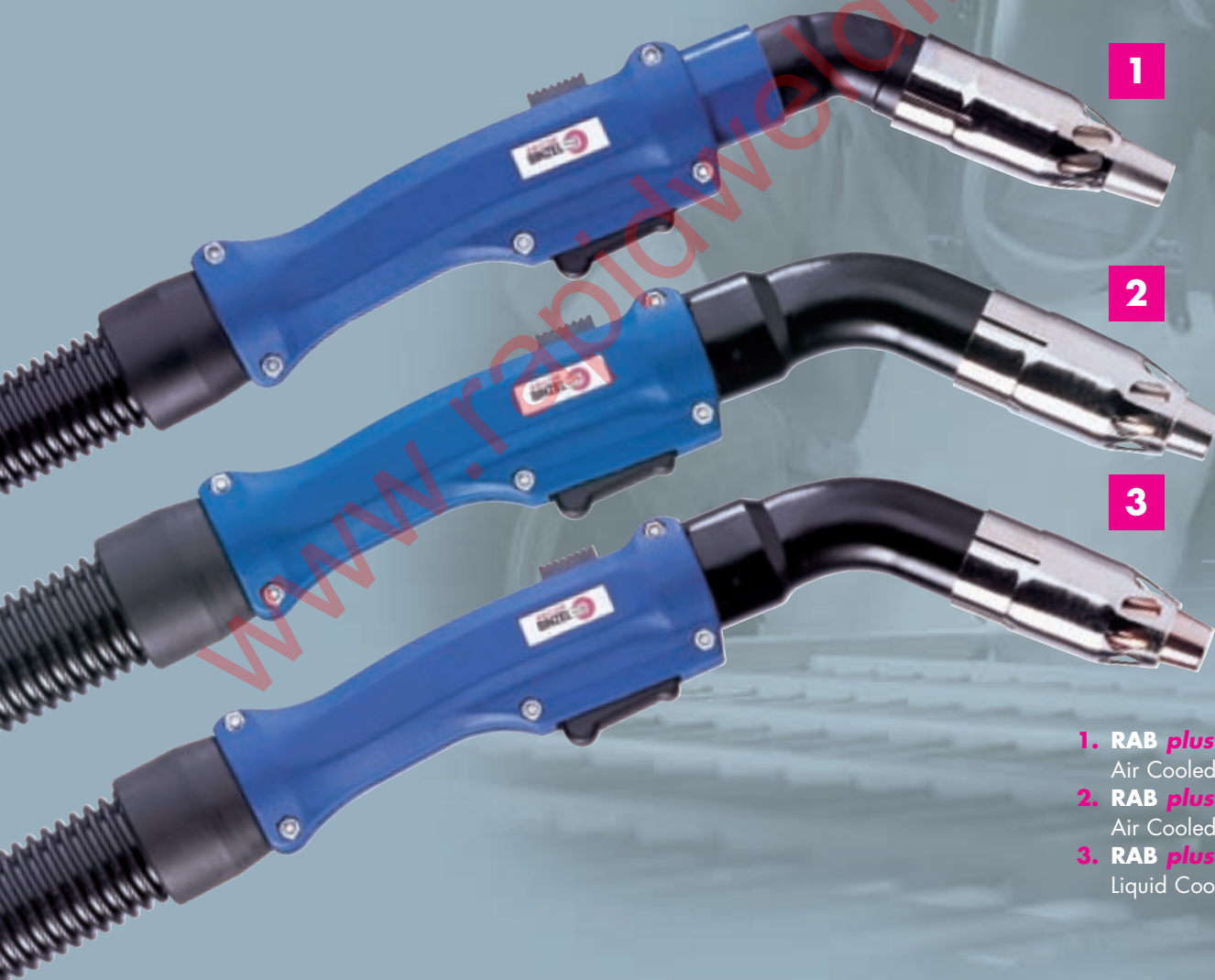

1. RAB *plus* 25 AK
Air Cooled
2. RAB *plus* 36 KD
Air Cooled
3. RAB *plus* 501 D
Liquid Cooled

FUMELINE

Alexander Binzel UK Ltd, Binzel House, Mill Lane, Winwick Quay, Warrington, Cheshire, WA2 8UA.
Tel : (01925) 653944 Fax : (01925) 654861 e-mail : info@binzelabicator.com website : www.binzelabicator.com

IBG
GROUP

Technology for the welder's world.

ABICOR
BINZEL

Air Cooled

RAB *plus* MIG/MAG Welding Torches

FUMELINE



RAB *plus* 25 AK

Technical Data (EN 60 974-7)

| Rating | Duty Cycle | Wire Size |
|------------------------------------------|------------|--------------|
| 230 A CO ² 200 A Mixed Gas | 60% | 0.8 - 1.2 mm |



Direct extraction at the arc guarantees welders protection against harmful fumes.



Handle complete with extraction control and swivel joint for optimized handling.



Same consumables as industry standard MB range.



WITHOUT FUME EXTRACTION



WITH FUME EXTRACTION

+ Special length manual torches are available on request.

Manual Torches

| Torch | 3 Metre | 4 Metre | 5 Metre |
|------------------------------|----------|----------|----------|
| RAB <i>plus</i> 25 AK | 604.2004 | 604.2005 | 604.2006 |

Technology for the welder's world.



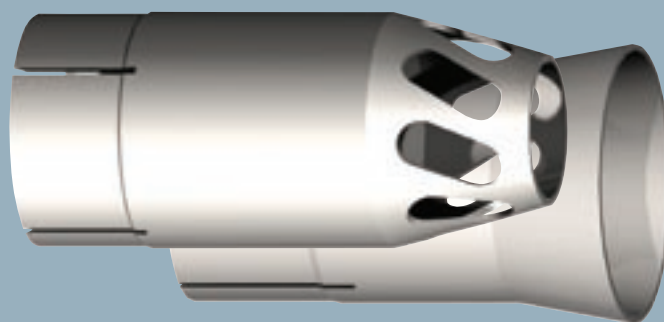

Gas Nozzles

Pack Size = 10

| Ø A | Type | Part Number |
|----------|--------------------|-------------|
| Ø 18mm | Cylindrical | 145.0042 |
| Ø 15mm | Conical | 145.0076 |
| Ø 11.5mm | Tapered | 145.0124 |

Fume Nozzles

Pack Size = 1

Part Number

| Standard | Funnel |
|----------|----------|
| 600.2004 | 602.0040 |

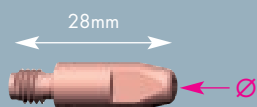

M6 Contact Tips

Pack Size = 50 (ABITIP® plus = 10)

+ A full range of our M6 contact tips is available.

| Diameter | Standard (E-Cu) | Heavy Duty (CuCrZr) | Aluminium | ABITIP® plus |
|----------|-----------------|---------------------|-----------|--------------|
| Ø 0.8 mm | 140.0051 | 140.0054 | 141.0001 | 144.0054 |
| Ø 1.0 mm | 140.0242 | 140.0245 | 141.0006 | 144.0245 |
| Ø 1.2 mm | 140.0379 | 140.0382 | 141.0010 | 144.0382 |

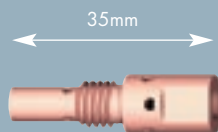

Tip Holder

Pack Size = 10

| | Std |
|-----------|----------|
| M6 | 142.0001 |
| M8 | 142.0015 |



Nozzle Spring

Pack Size = 10

| Std |
|----------|
| 003.0013 |



PVC Coated Liners

Protects against gas leakage through liner wall

| Colour | Diameter Ø | 3 Metre | 4 Metre | 5 Metre | 50 Metre Coil |
|--------|---------------------|----------|----------|----------|---------------|
| Blue | 0.6 - 0.8 mm | 124.0011 | 124.0012 | 124.0015 | 123.0004 |
| Red | 1.0 - 1.2 mm | 124.0026 | 124.0031 | 124.0035 | 123.0010 |



PTFE Liners

To be used for Aluminium welding

| Colour | Diameter Ø | 3 Metre | 4 Metre | 5 Metre | 50 Metre Coil |
|--------|---------------------|----------|----------|----------|---------------|
| Blue | 0.6 - 0.8 mm | 126.0005 | 126.0008 | 126.0011 | 125.0004 |
| Red | 1.0 - 1.2 mm | 126.0021 | 126.0026 | 126.0028 | 125.0006 |



Swan Neck

| | |
|-------------------|-----------------------|
| | RAB plus 25 AK |
| Inner Neck | 604.2001 |
| Outer Tube | 600.2001 |

Handle

| | |
|------------------------|-----------------------|
| | RAB plus 25 AK |
| Complete Handle | 180.0110 |
| Trigger | 185.0031 |
| Microswitch | 185.0027 |
| Vent Slider | 600.2016 |
| Hose Connector | 602.0080 |
| Screw | 079.0034 |

Cable Assembly

| | | | |
|---------------------|----------------------|----------------|----------------|
| | 3 Metre | 4 Metre | 5 Metre |
| Bikox® Cable | 160.0128 | 160.0142 | 160.0155 |
| Outer Hose | 109.0042 (per metre) | | |

Gun Plug Assembly

| | |
|------------------------|-----------------------|
| | RAB plus 25 AK |
| Gun Plug Body | 501.0003 |
| Liner Nut | 501.0082 |
| Spring Pins | 501.2378 |
| Locking Nut | 500.0213 |
| Black Housing | 501.2278 |
| T-piece Hose Connector | 602.0082 |

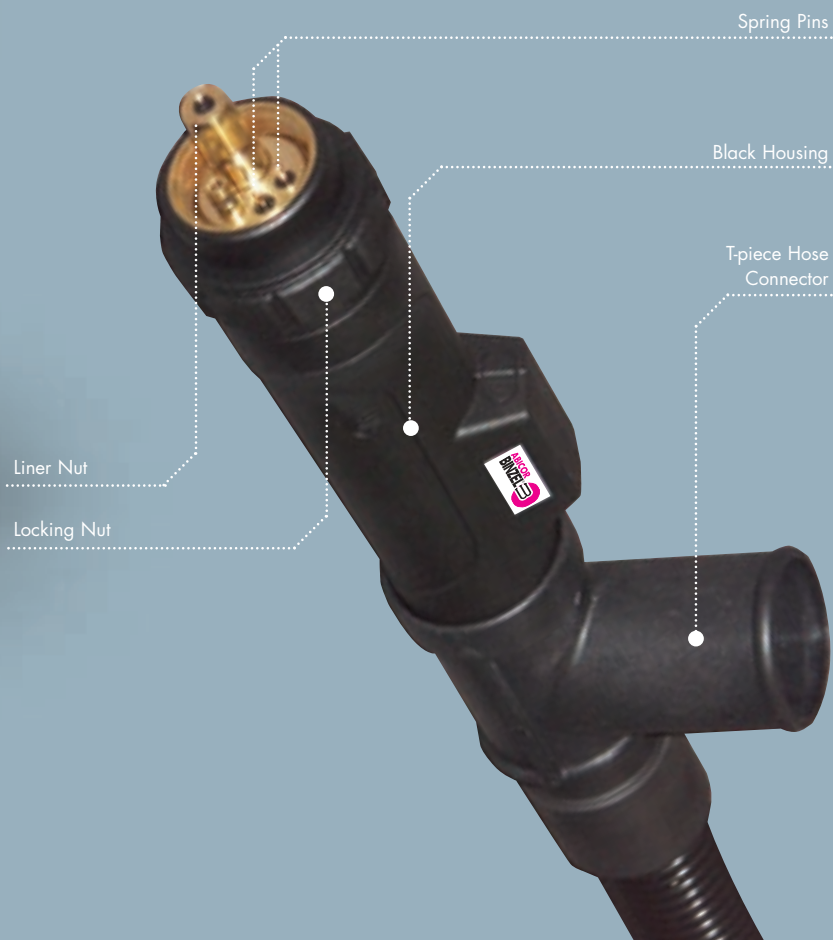

Fume Extraction at the Source.

RAB *plus* MIG/MAG Welding Torches Worldwide recognised.

- Air cooled up to 300 A.
- Liquid cooled up to 500 A.
- Direct extraction at the arc guarantees welders protection against harmful fumes.
- Small extraction tube diameter - better accessibility.
- Aluminium outer tube - considerable weight saving.
- Handle with extraction control and swivel joint - optimized handling.

Introducing the rest of the RAB *plus* range...

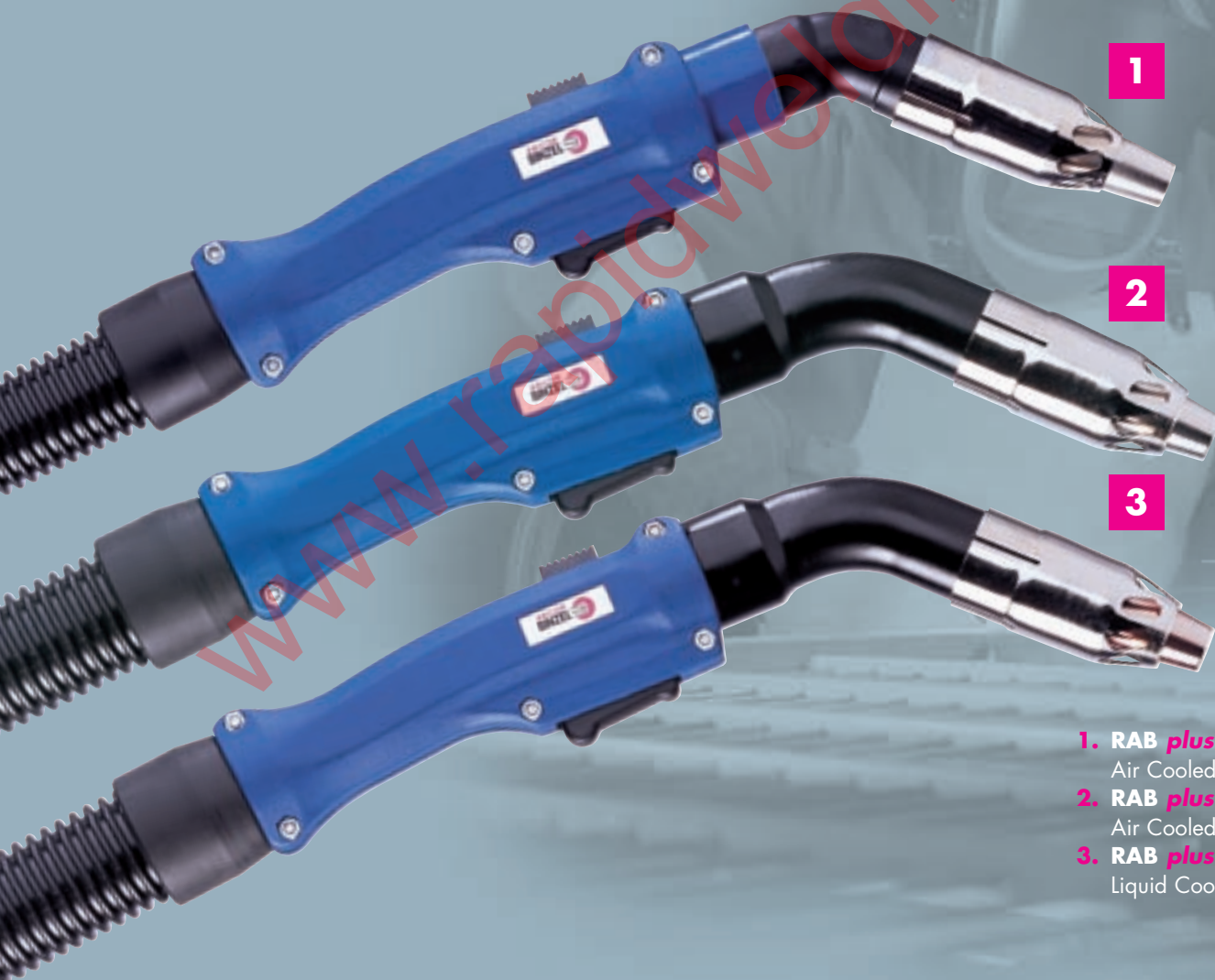

1. RAB *plus* 15 AK
Air Cooled
2. RAB *plus* 36 KD
Air Cooled
3. RAB *plus* 501 D
Liquid Cooled

FUMELINE

Alexander Binzel UK Ltd, Binzel House, Mill Lane, Winwick Quay, Warrington, Cheshire, WA2 8UA.
Tel : (01925) 653944 Fax : (01925) 654861 e-mail : info@binzelabicator.com website : www.binzelabicator.com

IBG
GROUP

Technology for the welder's world.

ABICOR
BINZEL®

Air Cooled

RAB plus MIG/MAG Welding Torches

FUMELINE



RAB plus 36 KD

Technical Data (EN 60 974-7)

| Rating | Duty Cycle | Wire Size |
|------------------------------------------|------------|--------------|
| 300 A CO ² 270 A Mixed Gas | 60% | 0.8 - 1.2 mm |



Direct extraction at the arc guarantees welders protection against harmful fumes.



Handle complete with extraction control and swivel joint for optimized handling.

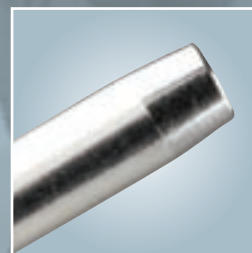

Same consumables as industry standard MB range.



+ Special length manual torches are available on request.

Manual Torches

| Torch | 3 Metre | 4 Metre | 5 Metre |
|-----------------------|----------|----------|----------|
| RAB plus 36 KD | 614.2002 | 614.2003 | 614.2004 |

Technology for the welder's world.



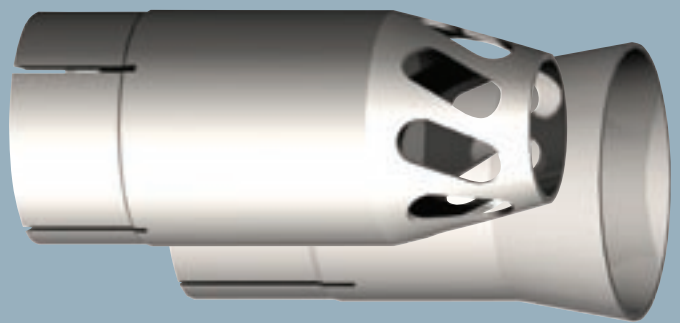
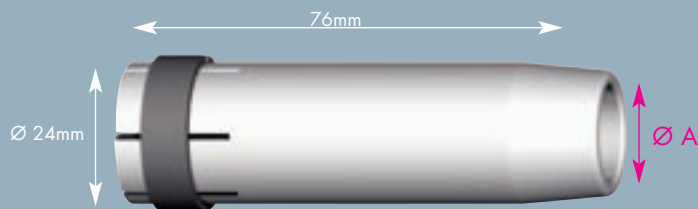

Gas Nozzles

Pack Size = 10

| Ø A | Type | Part Number |
|--------|--------------------|-------------|
| Ø 19mm | Cylindrical | 145.0045 |
| Ø 16mm | Conical | 145.0078 |
| Ø 12mm | Tapered | 145.0126 |

Fume Nozzles

Pack Size = 1

Part Number

| Standard | Funnel |
|----------|----------|
| 600.2006 | 612.0023 |

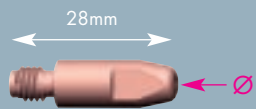

M6 Contact Tips

Pack Size = 50 (ABITIP® plus = 10)

A full range of our **M6** contact tips is available.

| Diameter | Standard (E-Cu) | Heavy Duty (CuCrZr) | Aluminium | ABITIP® plus |
|----------|-----------------|---------------------|-----------|--------------|
| Ø 0.8 mm | 140.0051 | 140.0054 | 141.0001 | 144.0054 |
| Ø 1.0 mm | 140.0242 | 140.0245 | 141.0006 | 144.0245 |
| Ø 1.2 mm | 140.0379 | 140.0382 | 141.0010 | 144.0382 |

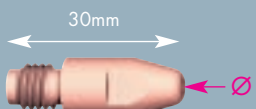

M8 Contact Tips

Pack Size = 50 (ABITIP® plus = 10)

A full range of our **M8** contact tips is available.

| Diameter | Standard (E-Cu) | Heavy Duty (CuCrZr) | Aluminium | ABITIP® plus |
|----------|-----------------|---------------------|-----------|--------------|
| Ø 0.8 mm | 140.0114 | 140.0117 | 141.0003 | 144.0117 |
| Ø 1.0 mm | 140.0313 | 140.0316 | 141.0008 | 144.0316 |
| Ø 1.2 mm | 140.0442 | 140.0445 | 141.0015 | 144.0445 |

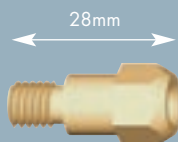

Std Tip Adaptor

Pack Size = 10

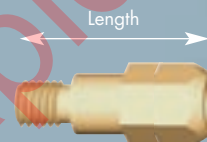

Long Tip Adaptor

Pack Size = 10

| | Std | Length | Long |
|-----------|----------|----------------|----------|
| M6 | 142.0005 | 32mm M6 | 142.0011 |
| M8 | 142.0020 | 34mm M8 | 142.0024 |

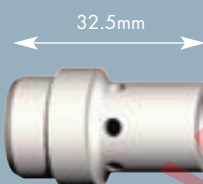

Gas Diffusor

Pack Size = 10

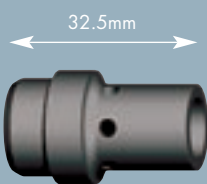

HD Gas Diffusor

Pack Size = 10

| | Part Number | Part Number |
|-------------------------|----------------------|-------------------|
| Standard Ceramic | 014.0261 014.0023 | Heavy Duty |
| | | 014.0026 |

PVC Coated Liners

Protect against gas leakage through liner wall

| Colour | Diameter Ø | 3 Metre | 4 Metre | 5 Metre | 50 Metre Coil |
|--------|---------------------|----------|----------|----------|---------------|
| Blue | 0.6 - 0.8 mm | 124.0011 | 124.0012 | 124.0015 | 123.0004 |
| Orange | 1.0 - 1.2 mm | 124.0026 | 124.0031 | 124.0035 | 123.0010 |

PTFE Liners

To be used for Aluminium welding

| Colour | Diameter Ø | 3 Metre | 4 Metre | 5 Metre | 50 Metre Coil |
|--------|---------------------|----------|----------|----------|---------------|
| Blue | 0.6 - 0.8 mm | 126.0005 | 126.0008 | 126.0011 | 125.0004 |
| Orange | 1.0 - 1.2 mm | 126.0021 | 126.0026 | 126.0028 | 125.0006 |



Swan Neck

| | |
|-------------------|-----------------------|
| | RAB plus 36 KD |
| Inner Neck | 614.2001 |
| Outer Tube | 600.2002 |

Handle

| | |
|------------------------|-----------------------|
| | RAB plus 36 KD |
| Complete Handle | 180.0110 |
| Trigger | 185.0031 |
| Microswitch | 185.0027 |
| Vent Slider | 600.2016 |
| Hose Connector | 602.0080 |
| Screw | 079.0034 |

Cable Assembly

| | | | |
|---------------------|----------------------|----------------|----------------|
| | 3 Metre | 4 Metre | 5 Metre |
| Bikox® Cable | 160.0364 | 160.0379 | 160.0391 |
| Outer Hose | 109.0042 (per metre) | | |

Gun Plug Assembly

| | |
|------------------------|-----------------------|
| | RAB plus 36 KD |
| Gun Plug Body | 501.0003 |
| Liner Nut | 501.0082 |
| Spring Pins | 501.2378 |
| Locking Nut | 500.0213 |
| Black Housing | 501.2278 |
| T-piece Hose Connector | 602.0082 |

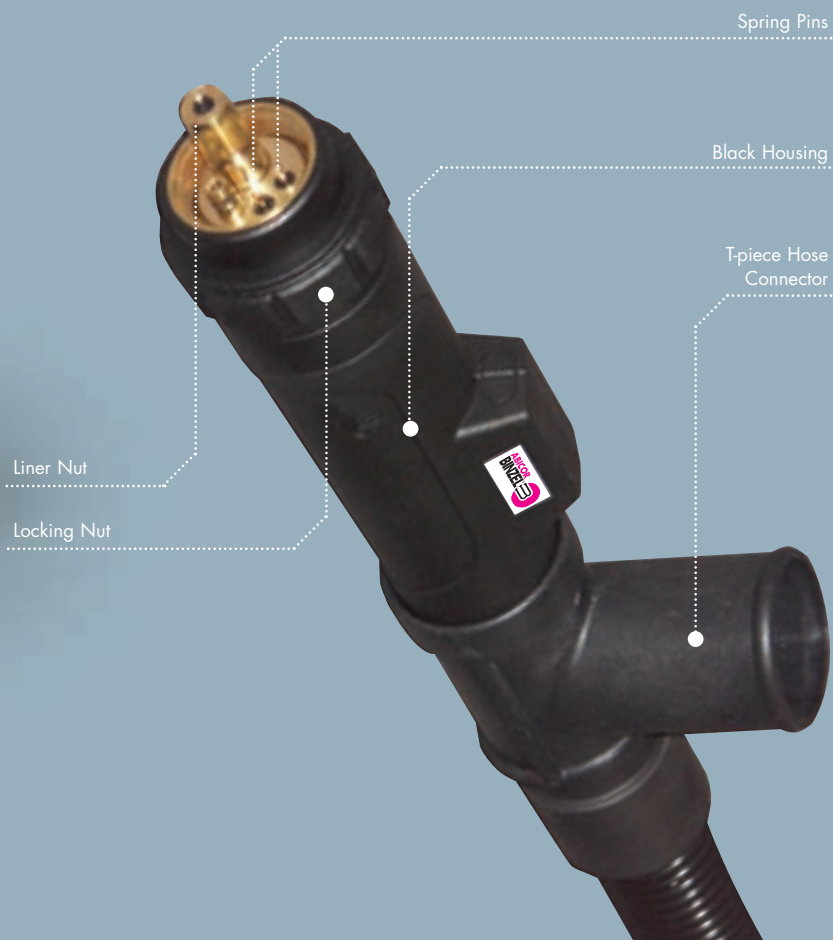

Fume Extraction at the Source.

RAB *plus* MIG/MAG Welding Torches Worldwide recognised.

- Air cooled up to 300 A.
- Liquid cooled up to 500 A.
- Direct extraction at the arc guarantees welders protection against harmful fumes.
- Small extraction tube diameter - better accessibility.
- Aluminium outer tube - considerable weight saving.
- Handle with extraction control and swivel joint - optimized handling.

Introducing the rest of the RAB *plus* range...

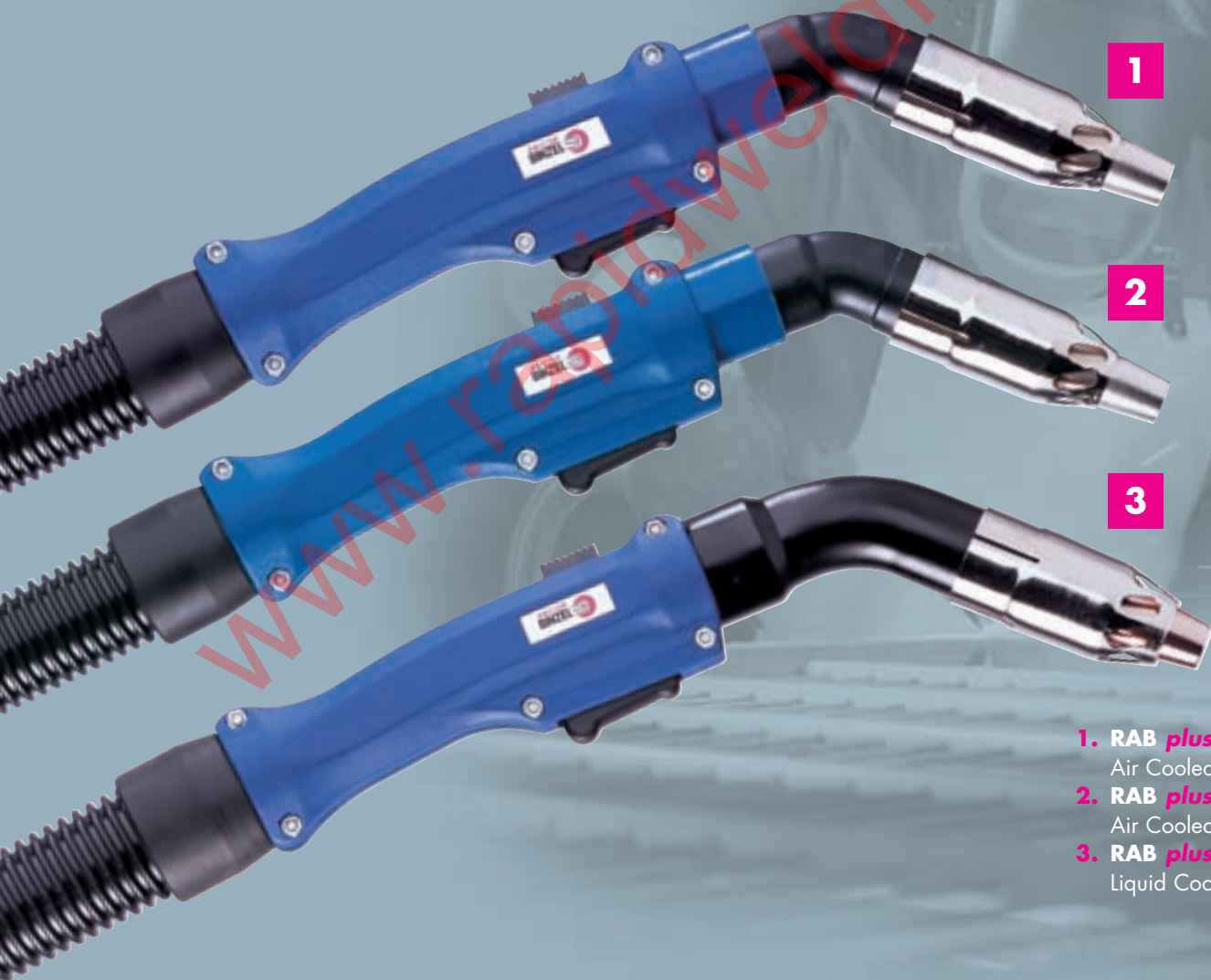

1. RAB *plus* 15 AK
Air Cooled
2. RAB *plus* 25 AK
Air Cooled
3. RAB *plus* 501 D
Liquid Cooled

FUMELINE

Alexander Binzel UK Ltd, Binzel House, Mill Lane, Winwick Quay, Warrington, Cheshire, WA2 8UA.
Tel : (01925) 653944 Fax : (01925) 654861 e-mail : info@binzel-abicor.com website : www.binzel-abicor.com

IBG
GROUP

Technology for the welder's world.

ABICOR
BINZEL

Liquid Cooled

RAB plus MIG/MAG Welding Torches

FUMELINE



RAB plus 501 D

Technical Data (EN 60 974-7)

| Rating | Duty Cycle | Wire Size |
|-----------------------|------------|--------------|
| 500 A CO ² | 100% | 1.0 - 1.6 mm |
| 450 A Mixed Gas | | |



Direct extraction at the arc guarantees welders protection against harmful fumes.



Handle complete with extraction control and swivel joint for optimized handling.



Same consumables as industry standard MB range.



WITHOUT FUME EXTRACTION



WITH FUME EXTRACTION

+ Special length manual torches are available on request.

Manual Torches

| Torch | 3 Metre | 4 Metre | 5 Metre |
|-----------------------|----------|----------|----------|
| RAB plus 501 D | 634.2002 | 634.2003 | 634.2004 |

Technology for the welder's world.



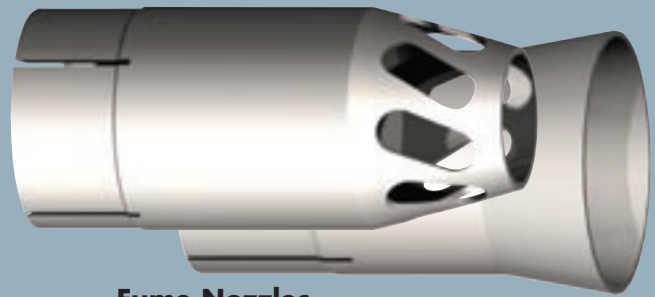
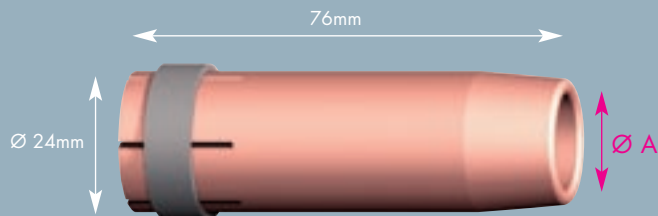

Gas Nozzles

Pack Size = 10

Fume Nozzles

Pack Size = 1

| Ø A | Type | Part Number |
|--------|--------------------|-------------|
| Ø 20mm | Cylindrical | 145.0051 |
| Ø 16mm | Conical | 145.0085 |
| Ø 14mm | Tapered | 145.0132 |

Part Number

| Standard | Funnel |
|----------|----------|
| 600.2006 | 612.0023 |

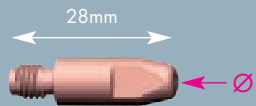

M6 Contact Tips

Pack Size = 50 (ABITIP plus = 10)

A full range of our M6 contact tips is available.

| Diameter | Standard (E-Cu) | Heavy Duty (CuCrZr) | Aluminium | ABITIP [®] plus |
|----------|-----------------|---------------------|-----------|--------------------------|
| Ø 0.8 mm | 140.0051 | 140.0054 | 141.0001 | 144.0054 |
| Ø 1.0 mm | 140.0242 | 140.0245 | 141.0006 | 144.0245 |
| Ø 1.2 mm | 140.0379 | 140.0382 | 141.0010 | 144.0382 |
| Ø 1.4 mm | 140.0516 | 140.0519 | 141.0019 | 144.0519 |
| Ø 1.6 mm | 140.0555 | 140.0558 | 141.0020 | 144.0558 |

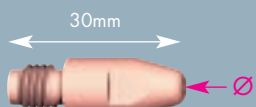

M8 Contact Tips

Pack Size = 50 (ABITIP plus = 10)

A full range of our M8 contact tips is available.

| Diameter | Standard (E-Cu) | Heavy Duty (CuCrZr) | Aluminium | ABITIP [®] plus |
|----------|-----------------|---------------------|-----------|--------------------------|
| Ø 0.8 mm | 140.0114 | 140.0117 | 141.0003 | 144.0117 |
| Ø 1.0 mm | 140.0313 | 140.0316 | 141.0008 | 144.0316 |
| Ø 1.2 mm | 140.0442 | 140.0445 | 141.0015 | 144.0445 |
| Ø 1.4 mm | 140.0533 | 140.0536 | 141.0055 | 144.0536 |
| Ø 1.6 mm | 140.0587 | 140.0590 | 141.0022 | 144.0590 |

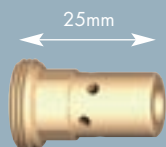

Std Tip Adaptor

Pack Size = 10

| | Std |
|-----------|----------|
| M6 | 142.0008 |
| M8 | 142.0022 |

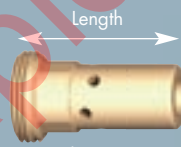

Long Tip Adaptor

Pack Size = 10

| Length | Long |
|-------------|----------|
| 29mm | 142.0013 |
| 31mm | 142.0027 |

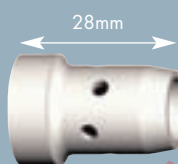

Gas Diffusor

Pack Size = 10

| | Part Number |
|-------------------------|-------------|
| Standard Ceramic | 030.0145 |
| | 030.0190 |

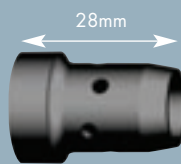

HD Gas Diffusor

Pack Size = 10

| | Part Number |
|-------------------|-------------|
| Heavy Duty | 030.0037 |



Steel Liners

Uncoated liner carry gas separate from the wire/liner

| Colour | Diameter Ø | 3 Metre | 4 Metre | 5 Metre | 50 Metre Coil |
|--------|---------------------|----------|----------|----------|---------------|
| □ | 0.6 - 0.8 mm | 122.0005 | 122.0007 | 122.0009 | 120.0009 |
| □ | 1.0 - 1.2 mm | 122.0031 | 122.0036 | 122.0039 | 120.0026 |
| □ | 1.4 - 1.6 mm | 122.0056 | 122.0060 | 122.0063 | - |



PTFE Liners

To be used for Aluminium welding

| Colour | Diameter Ø | 3 Metre | 4 Metre | 5 Metre | 50 Metre Coil |
|--------|---------------------|----------|----------|----------|---------------|
| ■ | 0.6 - 0.8 mm | 126.0005 | 126.0008 | 126.0011 | 125.0004 |
| ■ | 1.0 - 1.2 mm | 126.0021 | 126.0026 | 126.0028 | 125.0006 |
| ■ | 1.4 - 1.6 mm | 126.0039 | 126.0042 | 126.0045 | 125.0017 |

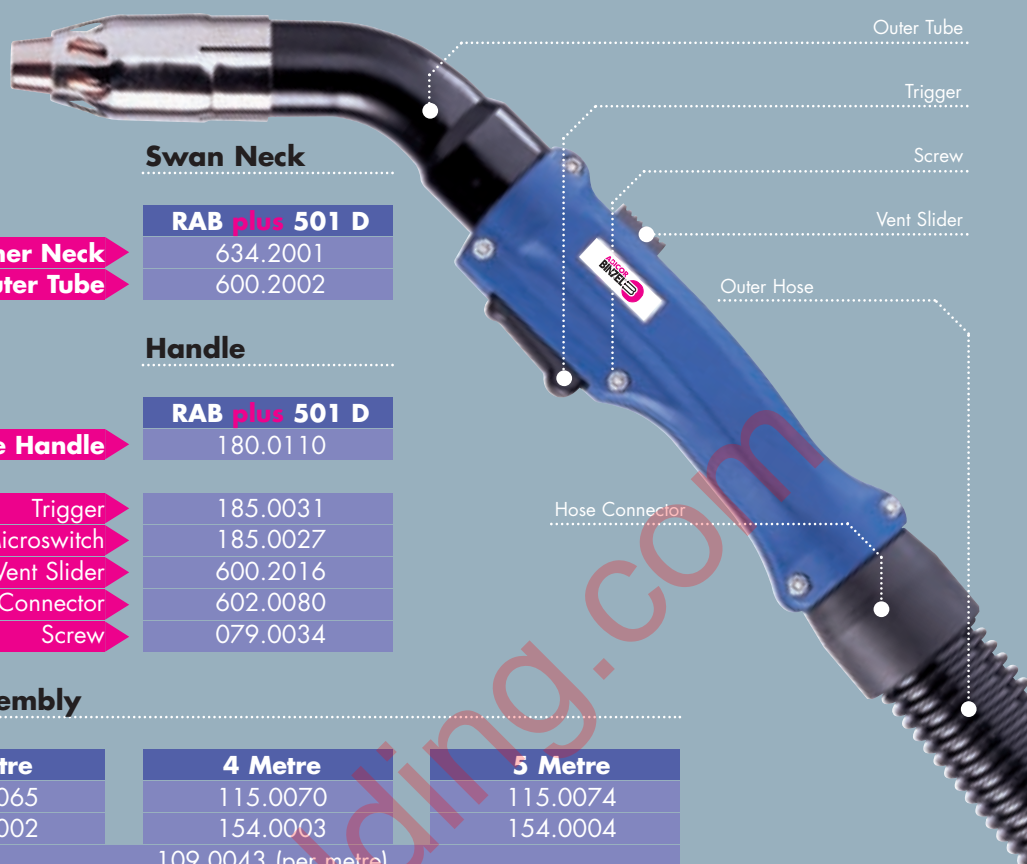

Swan Neck

| | |
|-------------------|-----------------------|
| | RAB plus 501 D |
| Inner Neck | 634.2001 |
| Outer Tube | 600.2002 |

Handle

| | |
|------------------------|-----------------------|
| | RAB plus 501 D |
| Complete Handle | 180.0110 |
| Trigger | 185.0031 |
| Microswitch | 185.0027 |
| Vent Slider | 600.2016 |
| Hose Connector | 602.0080 |
| Screw | 079.0034 |

Cable Assembly

| | 3 Metre | 4 Metre | 5 Metre |
|---------------------|----------------------|----------|----------|
| Power Cable | 115.0065 | 115.0070 | 115.0074 |
| Wire Conduit | 154.0002 | 154.0003 | 154.0004 |
| Outer Hose | 109.0043 (per metre) | | |
| Water Hose | 109.0052 (per metre) | | |
| Gas Hose | 109.0040 (per metre) | | |

+ A full range of our **Hose Clamps & Quick connectors** is available.

Water & Gas Hose Parts

| | Water Hose | Gas Hose |
|------------------------|------------|----------|
| Hose Clamp | 173.0001 | 171.0002 |
| Quick Connector | 501.0114 | - |
| Fastening Cap | 501.2423 | - |
| Fastening Cap | 501.2424 | - |
| Hose Marker | 501.2166 | - |
| Hose Marker | 501.2167 | - |

Gun Plug Assembly

| | |
|------------------------|-----------------------|
| | RAB plus 501 D |
| Gun Plug Body | 501.0015 |
| Liner Nut | 501.0082 |
| Spring Pins | 501.2378 |
| Locking Nut | 500.0213 |
| Black Housing | 501.2278 |
| T-piece Hose Connector | 602.0082 |



Fume Extraction at the Source.

RAB *plus* MIG/MAG Welding Torches Worldwide recognised.

- Air cooled up to 300 A.
- Liquid cooled up to 500 A.
- Direct extraction at the arc guarantees welders protection against harmful fumes.
- Small extraction tube diameter - better accessibility.
- Aluminium outer tube - considerable weight saving.
- Handle with extraction control and swivel joint - optimized handling.

Introducing the rest of the RAB *plus* range...

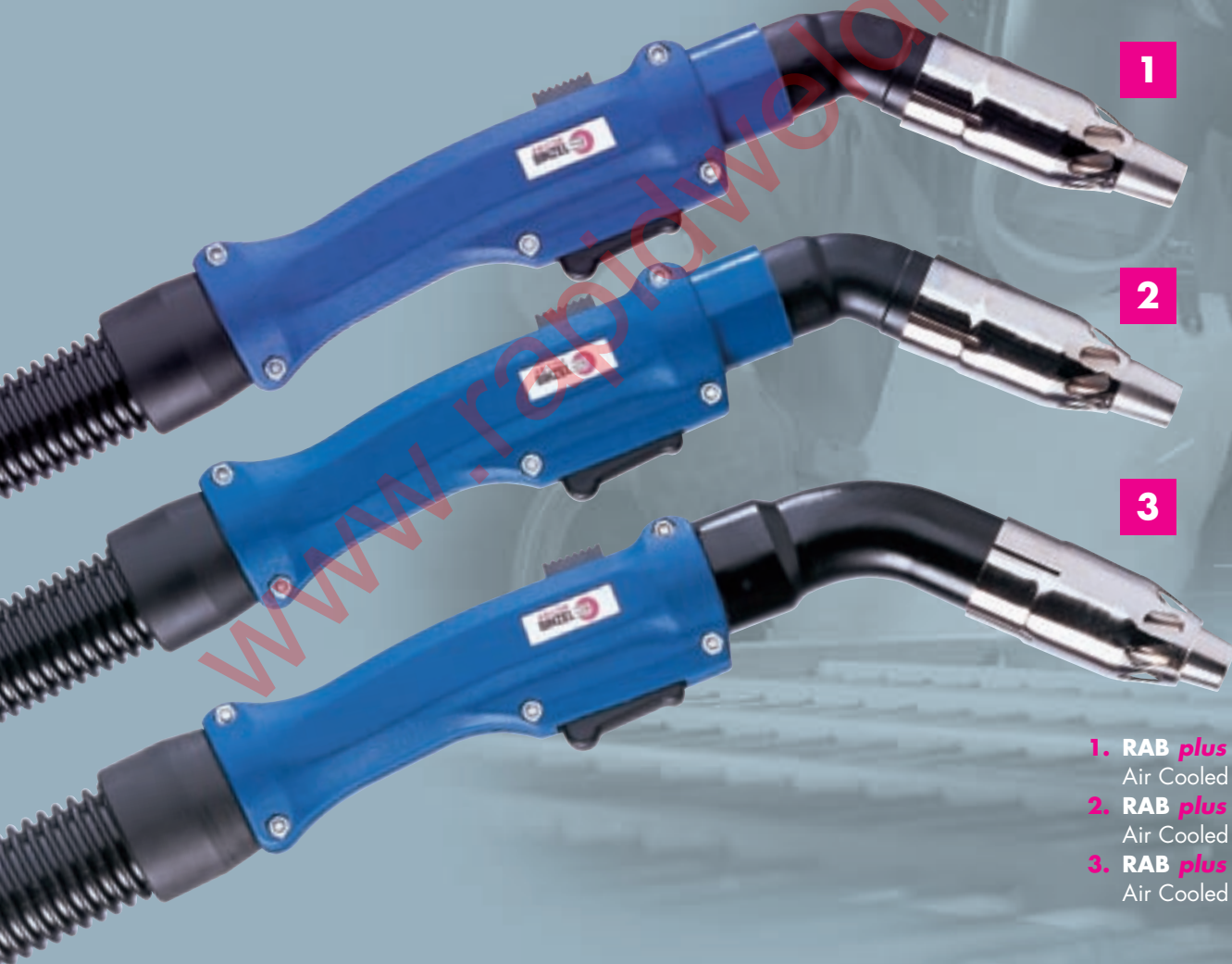

1. RAB *plus* 15 AK
Air Cooled
2. RAB *plus* 25 AK
Air Cooled
3. RAB *plus* 36 KD
Air Cooled

FUMELINE

Alexander Binzel UK Ltd, Binzel House, Mill Lane, Winwick Quay, Warrington, Cheshire, WA2 8UA.
Tel : (01925) 653944 Fax : (01925) 654861 e-mail : info@binzelabicator.com website : www.binzelabicator.com

IBG
GROUP

Technology for the welder's world.

ABICOR
BINZEL®