



Advanced Engineering
MIDDLETON LTD

batch mixer design and technology

5D Transpennine Trading Estate, Correls Way, Rochdale, Lancashire OL11 2PX
tel: 01706 759003 fax: 01706 759004 email: info@aemixers.com web: www.aemixers.com

AEROSOLS & BENTONITES • AGROCHEMICALS • ANIMAL & VEGETABLE PRODUCTS • ASBESTOS • BATH ADDITIVES • BEVERAGES • BITUMINOUS & HEAVY OIL MIXTURES • BUILDING CHEMICALS • CANE SUGAR • CARBON BLACK • CELLULOSE • CERAMICS • CHEESES & SAUCES • CLEANSING CREAMS • CMC • COD LIVER OIL • COSMETICS • CREAMS • DRUG EXTRACTS • DYES • FIBRES & TEXTILES • FILTER CAKE MASSES • FINE CHEMICALS • FOOD PROCESSING • GELATINE SOLUTIONS • GELATINS • GRAPHITE • HAZARDOUS MATERIALS • ICE CREAM • INKS • INFANT FOODS • LACTOSE AND GLUCOSE • LACQUERS • LEATHER • LECTHIN • LIPSTICK SUBSTANCES • LOTIONS • LUBRICANTS • MARGARINE • MAYONNAISE • MILK AND MILK PRODUCTS • MILK FAT • MOLYBDENUM DISULPHIDE • MUCILAGE • NATURAL RESINS • OINTMENTS • OLIVE OIL • ORGANIC TISSUES • PAINT AND VARNISH • PAPER • PARAFFIN • PARAFFIN EMULSIONS • PARTING & IMPREGNATING COMPOUNDS • PASTES • PECTINS • PETFOODS • PETROCHEMICALS • PHARMACEUTICALS • PHOSPHOR SUPPLEMENTARY COMPOUNDS • SWELLING AGENTS • SYNTHETICS • TOMATO KETCHUP • TOOTH PASTES • WASTE TREATMENT • WASTE WATER • WAX



mixer design & technology from Advanced Engineering

We design and produce highly efficient mixers used throughout the food processing, paint production, petrochemical and cosmetic industries. Our production workshop in Rochdale is staffed with skilled operators trained for quality work. Design and manufacturing is carried out to the highest engineering standards ensuring total quality at all stages of production. The highest grades of stainless steel are used in manufacture, coupled with high performance motors and mechanical shaft seals to provide a degree of performance, durability and reliability hard to match, let alone better. Increasing customer demand has dictated the necessity for developing a wide range of products that reflect technical innovations. Although our initial aim is to satisfy our customers production requirements our after sales support and services are available for the complete operational life of our products.



Our highly efficient mixers are used throughout the food processing, paint production, petrochemical and cosmetic industries.

repairs and refurbishments

We can undertake repairs and refurbishments of your existing mixing equipment. We offer a complete in-house or on-site refurbishing service to suit customers requirements. This is often a more cost effective solution for minor problems. All our repairs and refurbishments are done to meet the needs of the individual customer. We offer rapid turn-around times. All repairs and refurbishments meet the same high standards as our new products.

complete in-house service



Advanced Engineering
MIDDLETON LTD

5D Transpennine Trading Estate, Gorrels Way, Rochdale, Lancashire OL11 2PX
tel: 01706 759003 fax: 01706 759004 email: info@aemixers.com web: www.aemixers.com



■ standard immersion mixers

Advanced Engineering's high speed immersion mixers offer considerable advantages over conventional stirrer/agitator systems. They are precision built products designed to give long trouble-free operation.

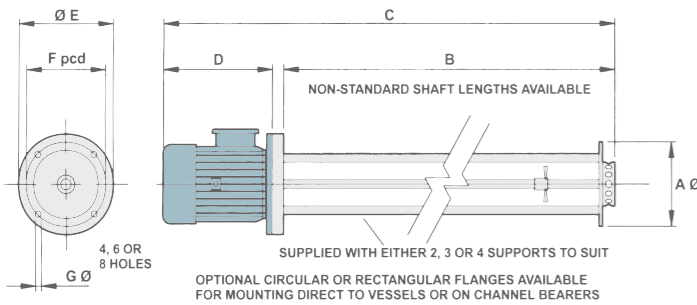

■ A precision designed rotor/stator arrangement is the key to their effective performance and high processing speeds. The bladed rotor rotates at high speed inside a fixed outer ring cutter or stator. This generates enormous centrifugal force drawing the material into the cutting chamber where it is subjected to a powerful mixing and cutting action.

■ It is then forced at high velocity centrifugally through the stator head generating high shear forces. The process is then repeated continuously with the entire vessel contents to give uniform and progressive processing of the material but with little or no aeration or surface disturbance.

■ By varying the rotor/stator arrangement, it is possible to produce a wide choice of shear ranges to suit different applications. Interchangeable heads mean that the same mixing machine can be used to perform a variety of functions including homogenising, blending, dispersing and emulsifying. We will also design special rotor/stator combinations for customers with specific requirements.

■ The machines are precision built to give long trouble-free service. All parts which come into contact with the product are grade 316 stainless steel, compatible with food and pharmaceutical requirements, as well as providing a high degree of chemical resistance to otherwise aggressive mediums.

Interchangeable Mixer Heads

A range of easily interchanged heads can be supplied so that machines can be adapted to offer a wide range of mixing operations. Easily interchangeable stator/rotor dispersion head combinations means each product can be treated with the best shear conditions for the medium. Cleaning and head replacement can be easily and quickly achieved with good access to all parts.



General Purpose - A versatile disintegrating head with a vigorous mixing action. Suitable for general purpose applications and the preparation of gels, thickeners, suspensions, solutions and slurries.



Slotted - Designed for the disintegration of fibrous materials including animal and vegetable tissues as well as the preparation of rubbers and polymers.



High Shear - The square hole configuration produces exceptionally high shear rates for the rapid reduction of soluble and insoluble granular solids and the preparation of emulsions and fine colloidal suspensions.



Emulsifying - Suitable for liquid/liquid preparations and emulsions. Can be supplied in fine, medium or coarse perforations.

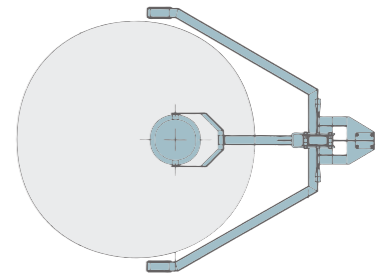
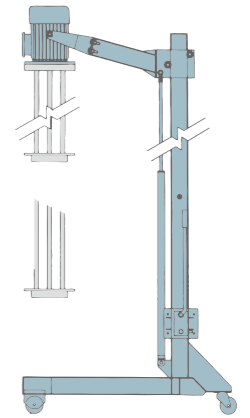

Mobile Hoist & transporter - A Mobile Hoist & transporter is available to suit most sizes of mixer. Raising and lowering is by hand powered hydraulic pump. 100mm diameter nylon tyred swivel braked castors permit easy movement and transportation between mixing vessels. A range of mixer flange sizes and drillings can be accommodated for mounting.



Rotors - Both Single sided and double sided units shown



Downthrust Propeller - Fitted to central drive shaft, with adjustable positioning to suit the application requirements

HIGH SPEED IMMERSION MIXER

all dimensions in millimetres

| Model No | hp | kW | rpm | A | B | C | D | E | F | G |
|----------|-----|------|------|-----|-----------------|------|-----|------------------------------|-----|----|
| | | | | | | | | Circular Flange Details Only | | |
| ADSI/1 | 1.0 | 0.75 | 2900 | 120 | 600 | 890 | 255 | 255 | 203 | 12 |
| ADSI/2 | 2.0 | 1.50 | 2900 | 160 | 700 | 1000 | 272 | 255 | 203 | 12 |
| ADSI/4 | 4.0 | 3.0 | 2900 | 165 | 800 | 1140 | 308 | 340 | 292 | 15 |
| ADSI/5.5 | 5.5 | 4.0 | 2900 | 165 | 1050 | 1400 | 321 | 340 | 292 | 15 |
| ADSI/10 | 10 | 7.5 | 2900 | 285 | 1225 | 1660 | 371 | 410 | 356 | 15 |
| ADSI/10 | 10 | 7.5 | 1450 | 285 | 1225 | 1660 | 371 | 410 | 356 | 15 |
| ADSI/10 | 10 | 7.5 | 960 | 420 | variable length | | | | | |
| ADSI/15 | 15 | 11 | 1450 | 368 | 1525 | 2090 | 495 | 485 | 406 | 19 |
| ADSI/20 | 20 | 15 | 2900 | 285 | 1225 | 1790 | 495 | 410 | 356 | 19 |
| ADSI/20 | 20 | 15 | 960 | 420 | variable length | | | | | |

Notes:
Purpose designed machines and larger models can be manufactured to suit customer requirements.
Mixing capacities vary according to the process material, viscosity, shape of vessel etc. and will progressively reduce as viscosity increases.

- Options:
- Additional materials of construction available
 - Atex approved motors and seals
 - Pneumatic motors or alternative voltages
 - Motor mounted Electronic speed control
 - Two speed motors
 - Custom Designs
 - Various vessel flange connections



■ special purpose mixers

Advanced Engineering special purpose mixer shown Fitted with 7.5kw motor and double stator head together with adjustable height baffle plate to prevent vortexing. 2, 3 or 4 support arms can be supplied to cover changes in working conditions due to varying material viscosity and shaft lengths.

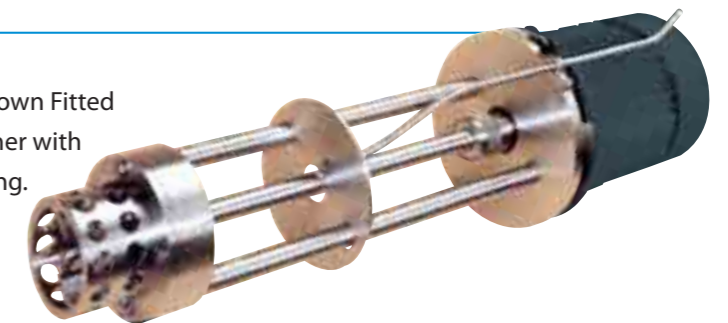



■ high speed sealed bearing mixers

Advanced Engineering's high speed sealed bearing mixers are designed specifically for use with materials which have a high abrasive content. They are precision built products, designed to give long, trouble-free operation.

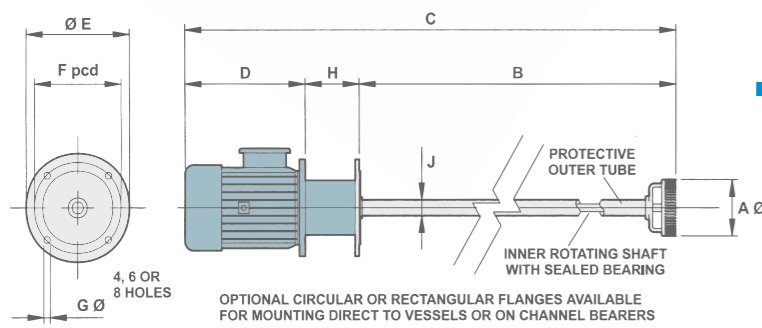

HIGH SPEED SEALED BEARING MIXER *all dimensions in millimetres*

| Model No | hp | kW | rpm | A | B | C | D | E | F | G | H | J |
|----------|-----|------|------|-----|------|------|-----|-----|-----|----|-----|----|
| ADSB-4 | 4 | 3 | 2900 | 115 | 965 | 1398 | 308 | 250 | 210 | 15 | 125 | 42 |
| ADSB-7.5 | 7.5 | 5.5 | 2900 | 150 | 965 | 1514 | 371 | 285 | 240 | 15 | 178 | 42 |
| ADSB-10 | 10 | 7.5 | 2900 | 150 | 965 | 1514 | 371 | 285 | 240 | 15 | 178 | 42 |
| ADSB-10 | 10 | 7.5 | 1450 | 220 | 1120 | 1674 | 371 | 405 | 355 | 15 | 183 | 70 |
| ADSB-15 | 15 | 11 | 1450 | 220 | 1120 | 1798 | 495 | 405 | 355 | 19 | 183 | 70 |
| ADSB-20 | 20 | 15 | 1450 | 280 | 1120 | 1798 | 495 | 460 | 410 | 19 | 183 | 70 |
| ADSB-25 | 25 | 18.5 | 1450 | 280 | 1120 | 1860 | 557 | 460 | 410 | 19 | 183 | 70 |

Notes:
Purpose designed machines and larger models can be manufactured to suit customer requirements.
Mixing capacities vary according to the process material, viscosity, shape of vessel etc. and will progressively reduce as viscosity increases.

- Options:**
- Additional materials of construction available
 - Special seal arrangements
 - ATEX approved motors
 - Pneumatic motors or alternative voltages
 - Motor mounted Electronic speed control
 - Two speed motors
 - Custom Designs
 - Various vessel flange connections

- A precision designed rotor/stator arrangement is the key to their effective performance and high processing speeds. The bladed rotor rotates at high speed inside a fixed outer ring cutter or stator. This generates enormous centrifugal force, drawing material into the cutting chamber, where it is subjected to a powerful mixing and cutting action.
- It is then forced at high velocity centrifugally through the stator head, generating high shear forces. The process is then repeated continuously with the entire vessel contents to give uniform and progressive processing of the material but with little or no aeration or surface disturbance.
- By varying the rotor/stator arrangement, it is possible to produce a wide choice of shear ranges to suit different applications. Interchangeable heads mean that the same mixing machine can be used to perform a variety of functions, including homogenising, blending, dispersing and emulsifying. We will also design special rotor/stator combinations for customers with specific requirements.
- The main drive shaft runs in a protective outer tube and is fitted with a sealed bearing, permitting use where there is limited access to the vessel. Cartridge mechanical shaft seal arrangements can also be supplied.
- We have 20 years experience designing and manufacturing immersion mixers. Larger models can be supplied to suit varying requirements including shape of mixing vessel, special fixings, material viscosity etc. If you have a specific requirement talk to our technical sales team.

Interchangeable Mixer Heads
A range of easily interchangeable heads can be supplied so that machines can be adapted to offer a wide range of mixing operations.



General Purpose - A versatile disintegrating head with 2 rows of holes coupled with a double action rotor to give vigorous mixing action. Suitable for thick solutions and slurry.

General Purpose Twin Head - A disintegrating head with a combination of holes and slots coupled with double action rotor to ensure materials are given one or two stage mixing without changing the stator.

Single Castle - The single castle head coupled with a single castle rotor is designed for the production of emulsions and suspended matter in an average viscosity range.

Double Castle - The double castle head and single castle rotor combination is designed for use with materials of higher viscosities. Typical application being dispersion of pigments.

Specialised Variations - Triple castle head combined with double castle rotor, used in thin emulsions and suspended matter with a low content of solids when high particle fineness is to be obtained.

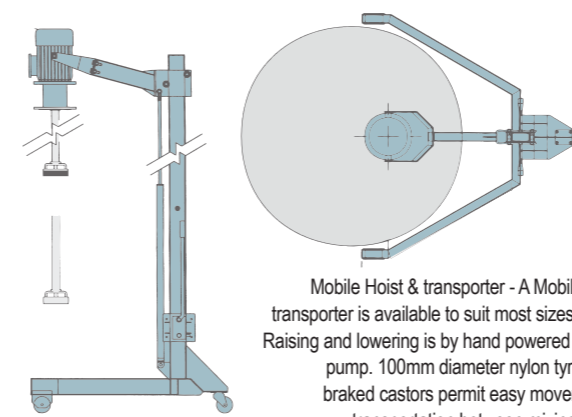

Mobile Hoist & transporter - A Mobile Hoist & transporter is available to suit most sizes of mixer. Raising and lowering is by hand powered hydraulic pump. 100mm diameter nylon tyred swivel braked castors permit easy movement and transportation between mixing vessels. A range of mixer flange sizes and drillings can be accommodated for mounting.

■ bottom entry mixers

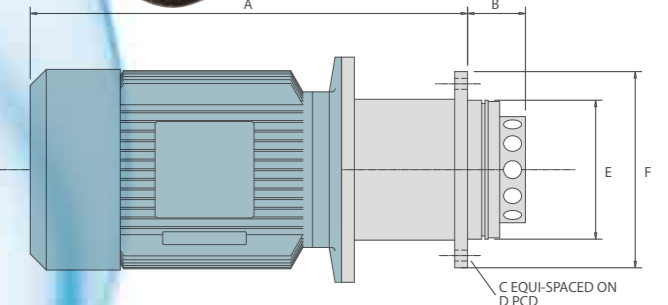
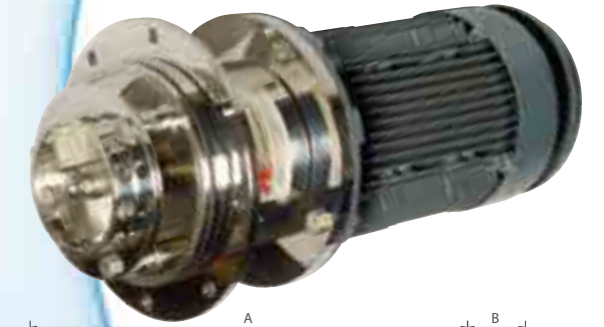

| MODEL | Kw | A | B | C | D | E | F |
|-----------|-----|-----|-----|--------|-----|-----|-----|
| ADBE 1.5 | 1.1 | 320 | 75 | 14 X 6 | 178 | 130 | 210 |
| ADBE 3.0 | 2.2 | 407 | 115 | 14 X 8 | 215 | 180 | 250 |
| ADBE 5.5 | 4 | 457 | 120 | 14 X 8 | 215 | 180 | 250 |
| ADBE 10.0 | 7.5 | 546 | 125 | 14 X 8 | 241 | 197 | 267 |
| ADBE 20.0 | 15 | 650 | 130 | 17 X 8 | 267 | 216 | 305 |

The Bottom Entry Mixer/Homogeniser is designed to fit directly on to the base of a vessel. This model range goes between 0.75Kw to 15Kw or up to a working capacity of 3000 litres.

We can offer single and two speed motors or with ATEX approval where required. The seal arrangement can either be double or single mechanical seals.



A range of easily interchangeable heads can be supplied similar to that of the Standard Immersion Mixer.

