



[www.matconibc.com](http://www.matconibc.com)



## IBC Blending Module

**Mix Any Recipe - Any Time**

- *Full Flexibility, no need for Inventory*
- *Deliver next day to your customer*





www.matconibc.com

# IBC Blending Module...

...eliminate time consuming cleaning associated with traditional static mixers. A truly revolutionary mixing approach improving your efficiency and reducing cost/kg produced.

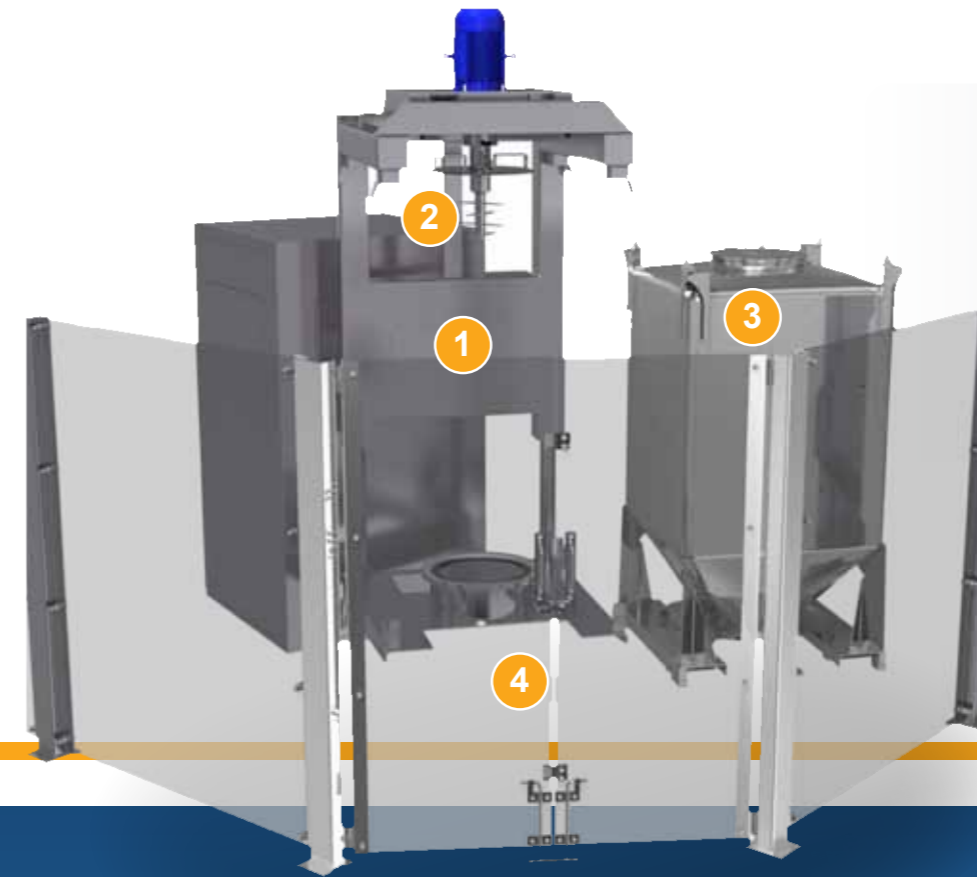

### Key Features

- 1 IBC Blender
- 2 Intensifier Assembly (optional)
- 3 Matcon IBC 'Portable Batch Vessel'
- 4 Safety Cage (optional)



	Setpoint	Actual
Time	30 : 00	00 : 00
Speed	12	11
High shear speed	1000	

START BLEND CYCLE

DIAGNOSTICS    Return



## The Goals of Lean Powder Processing

- Reduce the cost per kilogram manufactured
- Maximise plant flexibility - make to order
- Enable rapid product change-over
- Optimise flow manufacturing
- Reduce inventory – improve cash utilisation

### Key Benefits

- ▶ System is always Blending - Filling, Emptying and Cleaning are Done Offline
- ▶ Instant Recipe Changes without Risk of Contamination
- ▶ Wide Range of Batch Sizes for Further Flexibility
- ▶ Intensifier Package expands Blending Capability including Liquid Addition
- ▶ Stand-alone / decoupled operation – maximum flexibility
- ▶ Modular solution – factory assembled – proven design – low risk





www.matconibc.com

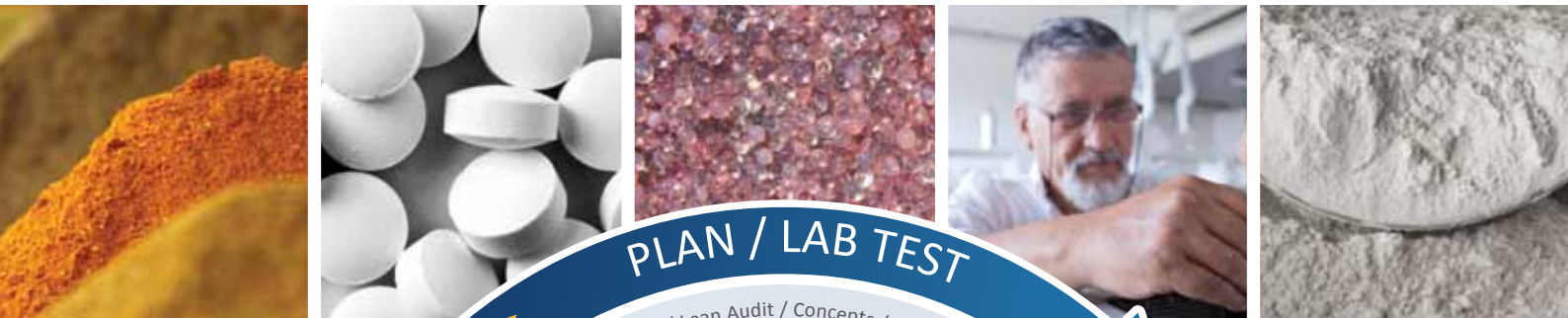

MATCON, Bramley Drive, Vale Park West, Evesham, Worcestershire, WR11 1JH, UK  
Tel: +44 (0) 1386 769 000 Fax: +44 (0) 870 1911116 Email: matcon\_marketing@idexcorp.com

